

TIANMUSHAN

天目山

希尔顿格芮精选酒店

HILTON GREY'S CHOICE HOTEL

艺术品方案

Artwork Proposal



天目三千丈，东南第一峰。4亿年前，浩瀚的汪洋在剧烈的地壳碰撞中隆起了山脉的雏峰，一座横亘江南古陆、岿然屹立于北纬30°的“浙西诸山之祖”——天目山傲然崛起。天目山源出昆仑，地处浙江省西北部，呈西北向东南走势，逶迤浙皖两省，主脉绵延至杭州，主体有东、西两峰，峰顶各一池，形若双眼，得名“天目”。



天目山！这座素有“大树华盖闻九州”之誉的山峰，不仅是国家4A级旅游景区，更是被誉为“清凉世界”、“大树王国”的美丽地方。

TIANMU MOUNTAIN! THIS MOUNTAIN PEAK, KNOWN AS THE "GREAT TREE COVERING THE NINE PROVINCES", IS NOT ONLY A NATIONAL 4A LEVEL TOURIST ATTRACTION, BUT ALSO A BEAUTIFUL PLACE KNOWN AS THE "COOL WORLD" AND "KINGDOM OF GREAT TREES".

地理位置:

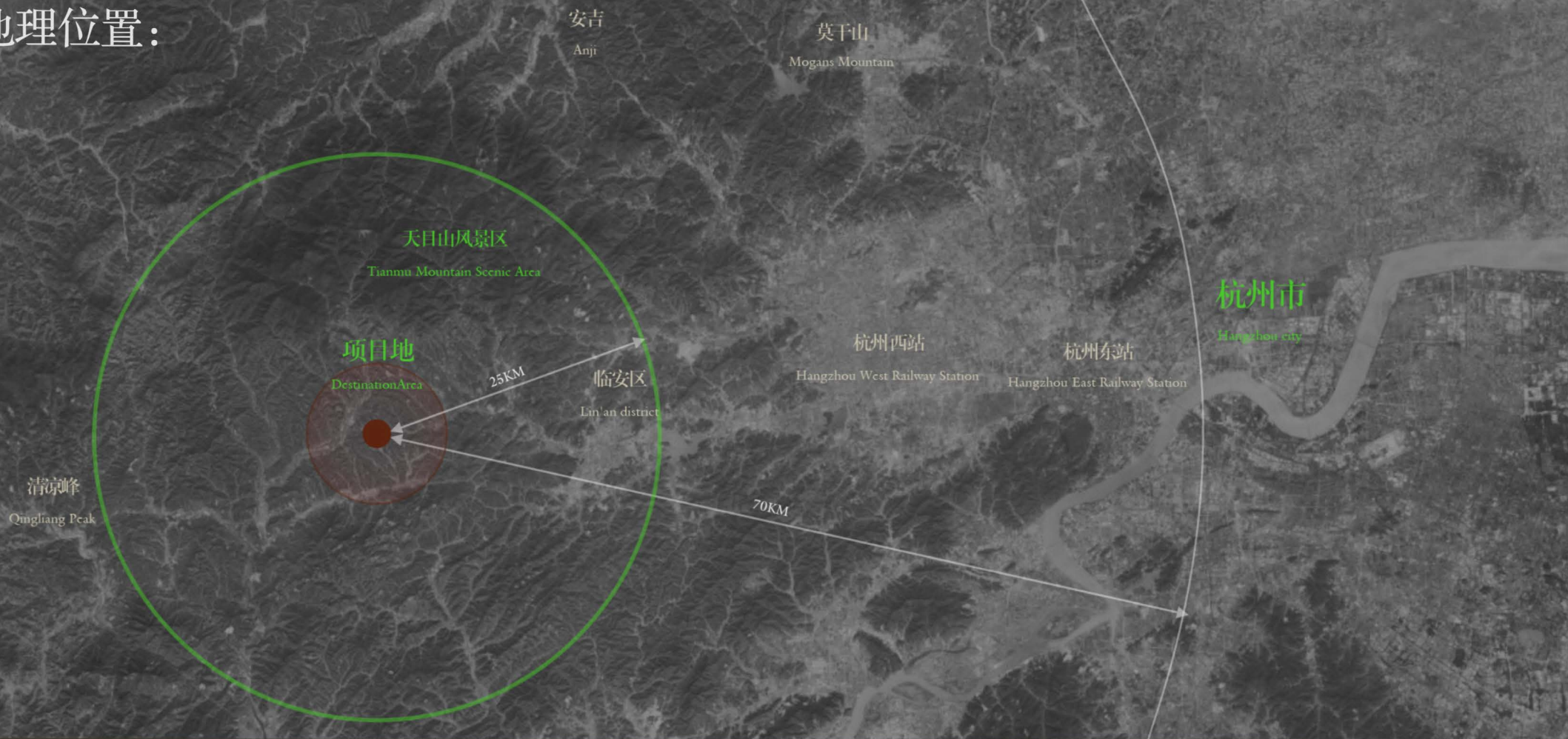

项目位置位于临安区於潜镇绍鲁村背靠天目山风景区。
地处浙江省杭州市西北部临安区境内，浙皖两省交界处，天目山是我国著名的自然保护区，也是浙江省加入国际生物圈保护区网络的自然保护区。

THE PROJECT IS LOCATED IN SHAOLU VILLAGE, YUQIAN TOWN, LIN'AN DISTRICT, BACKED BY THE TIANMU MOUNTAIN SCENIC AREA. LOCATED IN LIN'AN DISTRICT, NORTHWEST OF HANGZHOU CITY, ZHEJIANG PROVINCE, AT THE JUNCTION OF ZHEJIANG AND ANHUI PROVINCES, TIANMU MOUNTAIN IS A FAMOUS NATURE RESERVE IN CHINA AND ALSO A NATURAL RESERVE THAT ZHEJIANG PROVINCE HAS JOINED THE INTERNATIONAL BIOSPHERE RESERVE NETWORK.



青山绿水，风过蝉鸣，打开天目，领略天目山的四季自然变化
天目山是一座充满诗意的山，一座富有智慧的山，一座四季如画的山~

GREEN MOUNTAINS AND CLEAR WATERS, CICADAS CHIRPING IN THE WIND, OPEN TIANMU MOUNTAIN AND EXPERIENCE THE NATURAL CHANGES OF
THE FOUR SEASONS IN TIANMU MOUNTAIN
TIANMU MOUNTAIN IS A POETIC MOUNTAIN, A WISE MOUNTAIN, AND A PICTURESQUE MOUNTAIN THROUGHOUT THE FOUR SEASONS~

Tianmu Mountain

天目山的

春

春，是万物复苏的序曲
春天是生机勃勃的季节
春天播种希望，万物茁壮成长

一树留春，万古长青

SPRING IS THE PRELUDE TO THE REVIVAL OF ALL THINGS
SPRING IS A VIBRANT SEASON
SPRING SOWS HOPE, AND ALL THINGS THRIVE AND GROW
A TREE LEAVES SPRING, FOREVER GREEN

spring

Tianmu Mountain

天目山的

夏

夏天是热情洋溢的季节，阳光灿烂
夏天**繁花**盛开，让人陶醉其中
繁花似锦的夏日，是大自然的奇迹

SUMMER IS A SEASON FULL OF ENTHUSIASM, WITH BRIGHT SUNSHINE
IN SUMMER, THE BLOOMING FLOWERS MAKE PEOPLE INTOXICATED
THE BLOOMING SUMMER IS A MIRACLE OF NATURE

summer

Tianmu Mountain

天目山的

秋

秋，是丰收硕果的协奏
秋天落叶纷飞，金风送爽，银杏树叶飘散

浮云卷尽秋天高，月光照水翻金涛

AUTUMN IS A CONCERTO OF FRUITFUL HARVEST
IN AUTUMN, FALLING LEAVES FALL PROFUSELY, THE GOLDEN WIND
SENDS A REFRESHING BREEZE, AND THE GINKGO LEAVES DRIFT AWAY
FLOATING CLOUDS ROLL UP HIGH IN AUTUMN, THE MOONLIGHT SHINES
ON THE WATER AND TURNS THE GOLDEN WAVES

autumn

天目山的

冬

冬，是静谧温馨的尾声
雪花飘落，寒风刺骨，冰川雪山
冬日暖阳，寒梅傲立雪中

树林里的植物储存能量，等待来年绽放

WINTER IS THE QUIET AND WARM ENDING
SNOWFLAKES FALLING, COLD WINDS PIERCING, GLACIERS AND SNOW MOUNTAINS
UNDER THE WARM WINTER SUN, THE GOLD PLUM STANDS PROUDLY IN THE
FOREST. THE PLANTS IN THE FOREST STORE ENERGY AND WAIT FOR THEM TO
BLOOM NEXT YEAR.

winter

四季变化

天目山四季如诗，如梦般变幻，每一次的交替都带着大自然独特的韵味，以独特的丰富自然资源为设计元素，树木、果实、叶脉、溪水串联起来，森林生态系统及生物多样性，构成一幅优美画卷。

THE FOUR SEASONS OF TIANYU MOUNTAIN ARE LIKE POETRY, CHANGING LIKE A DREAM. EACH ALTERNATION CARRIES A UNIQUE CHARM OF NATURE, WITH UNIQUE AND RICH NATURAL RESOURCES AS DESIGN ELEMENTS. TREES, FRUITS, LEAF VEINS, AND STREAMS ARE CONNECTED, AND THE FOREST ECOSYSTEM AND BIODIVERSITY FORM A BEAUTIFUL PICTURE.

DESIGN CONCEPT

设计理念

天目山的四季变化为设计灵感来源，以“寻找森林秘境”为设计主题，引天目自然入秘境中，将天目山的色彩与自然语言贯穿整个设计空间中，运用现代艺术手法，借助自然生态树、花、种子、果实等为设计元素。以生态优先、自然融合、沉浸式体验为核心，打造一个充满自然魅力和生态活力的空间，让人们能够在其中感受到大自然的美好和力量。

THE FOUR-SEASON CHANGES IN TIANMU MOUNTAIN ARE THE SOURCE OF DESIGN INSPIRATION, WITH THE DESIGN THEME OF "SEARCHING FOR THE SECRET FOREST". INTRODUCE TIANMU NATURE INTO THE SECRET REALM, AND INTEGRATE THE COLORS AND NATURAL LANGUAGE OF TIANMU MOUNTAIN INTO THE ENTIRE DESIGN SPACE. USING MODERN ARTISTIC TECHNIQUES, NATURAL ECOLOGICAL TREES, FLOWERS, SEEDS, FRUITS, ETC. ARE USED AS DESIGN ELEMENTS.

WITH ECOLOGICAL PRIORITY, NATURAL INTEGRATION, AND IMMERSIVE EXPERIENCE AS THE CORE, WE CREATE A SPACE FULL OF NATURAL CHARM AND ECOLOGICAL VITALITY, WHERE PEOPLE CAN FEEL THE BEAUTY AND POWER OF NATURE.

设计思路

大堂区

森林奇境
Forest wonderland

康体区
团客接待

槃根错节
involved

全日餐厅&中餐

花园秘境
Garden Secret

行政酒廊

涓涓细流
tricklet

研学中心

籽种孕育&
岁月年轮

Seed Breeding&Year rings

客房

枝繁叶茂
with luxuriant foliage

结合天目山四季风景的地质特色所孕育出的万物，参天大树，树根汲取溪水养分，枝繁叶茂，结出繁花朵朵、硕果累累……

ALL THINGS NURTURED BY THE GEOLOGICAL CHARACTERISTICS OF THE FOUR SEASON SCENERY OF TIANMU MOUNTAIN, TOWERING TREES WITH ROOTS ABSORBING NUTRIENTS FROM THE STREAM WATER, WITH LUSH BRANCHES AND LEAVES, BEARING NUMEROUS FLOWERS AND FRUITS...



一层大堂

LOBBY ON THE FIRST FLOOR

[森林奇境]

Forest wonderland

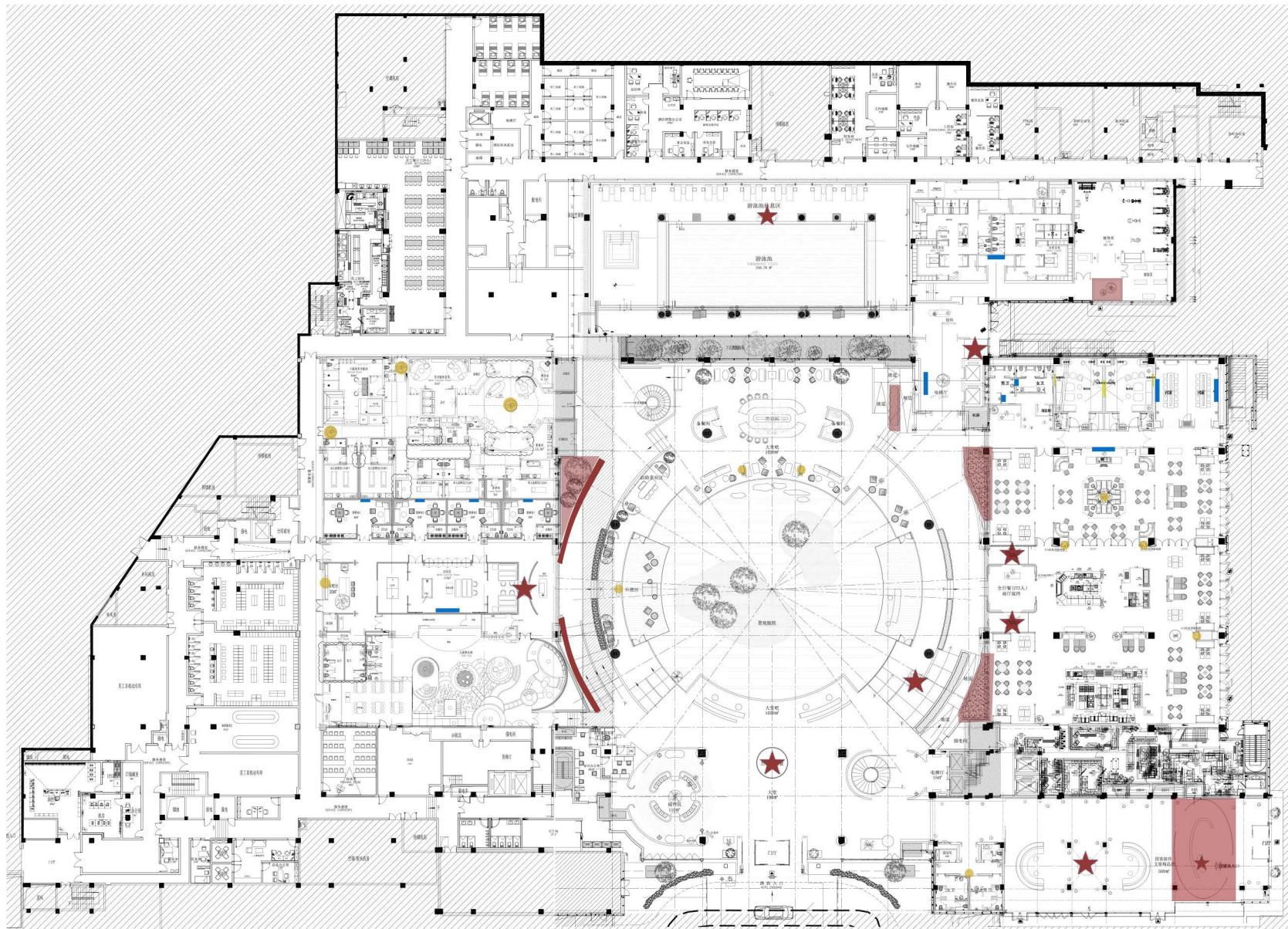

一层总平面

注：所有艺术品点位位置需要灯光配合



一层大堂接待效果图

FIRST FLOOR LOBBY RECEPTION RENDERINGS

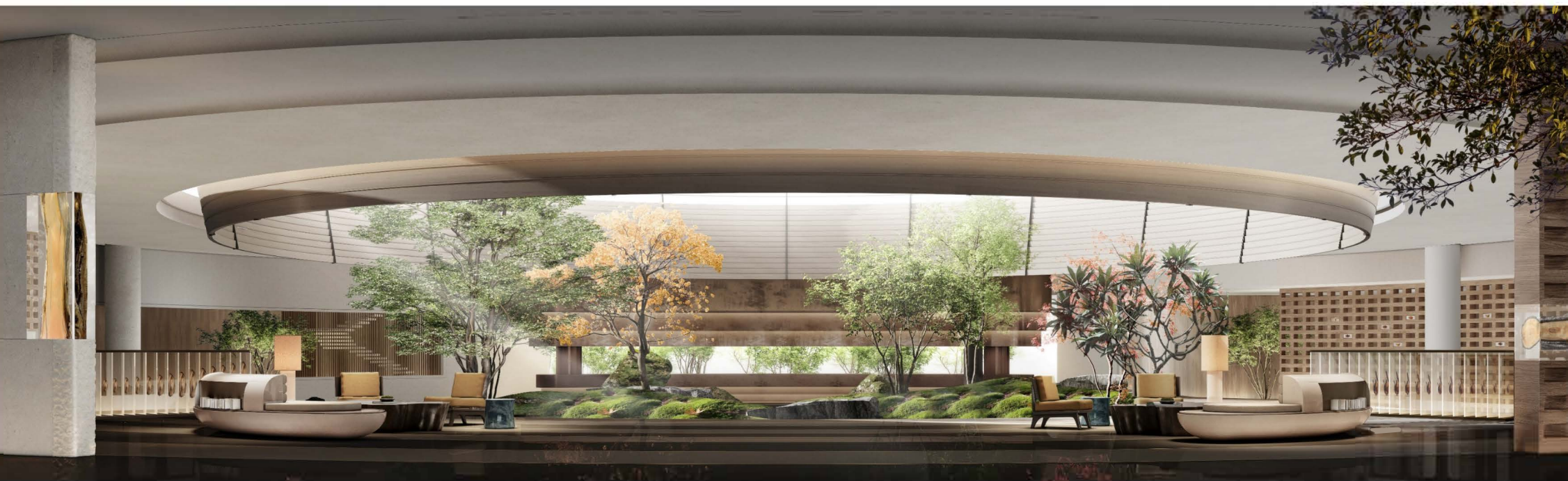

一层大堂效果图

FIRST FLOOR LOBBY RENDERINGS

FIRST FLOOR LOBBY



森林奇境

在时光的流转中，一束轻盈的蒲公英悄然飘落，似灵动的使者，牵引着我们的脚步。艺术装置，宛如大自然的精灵，完美地融入了自然的怀抱。它的轮廓恰似那随风飘舞的蒲公英，散发着一种空灵之美。整体如云朵般轻盈缥缈，仿佛随时都能随风而去，却又静静地伫立在那里，成为一道独特的风景。沉浸在这如梦如幻的氛围中，感受着自然与艺术的完美融合所带来的心灵震撼。

FOREST WONDERLAND

IN THE FLOW OF TIME, A LIGHT BUNDLE OF DANDELIONS QUIETLY FALLS, LIKE AGILE MESSENGERS, GUIDING OUR FOOTSTEPS. THE ART INSTALLATION, LIKE AN ELF OF NATURE, PERFECTLY BLENDS INTO THE EMBRACE OF NATURE. ITS OUTLINE IS LIKE A DANDELION DANCING IN THE WIND, EMITTING AN ETHEREAL BEAUTY. THE WHOLE IS AS LIGHT AND ETHEREAL AS CLOUDS, AS IF IT CAN BE BLOWN AWAY WITH THE WIND AT ANY TIME, YET STILL STANDING QUIETLY THERE, BECOMING A UNIQUE LANDSCAPE. IMMERSE YOURSELF IN THIS DREAMLIKE ATMOSPHERE AND FEEL THE SPIRITUAL SHOCK BROUGHT BY THE PERFECT FUSION OF NATURE AND ART.

森林奇境

Forest Wonderland

Forest Wonderland



Project 项目名称: 杭州天目山格芮精选希尔顿酒店 Serial number 项目编号: 1F-LO-01

Area 区域: 一层大堂

Number 数量: 1组

Material 材质: 叶片水晶吊饰+中央水晶种子吊饰
+镜面波纹黑色石材底座+安装配件

Size 尺寸: 吊饰: W3000*D3000*H2500, 底座: W3000*D3000*H300

Process description 工艺说明:

Lobby · Artworks

大堂·艺术品



材质细节: 叶片水晶吊饰



天花固定示意:

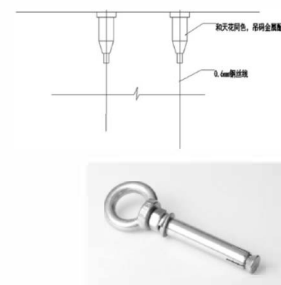

中间种子形态艺术装置

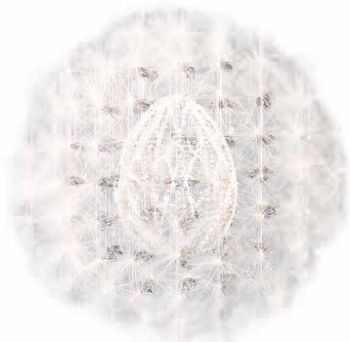

底座材质细节:



底座:

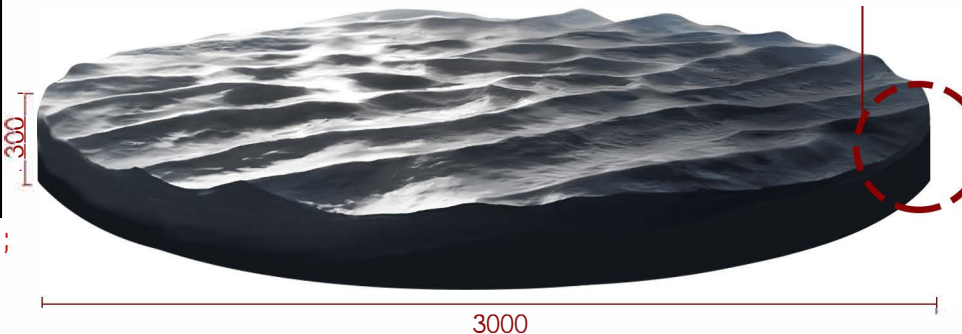

底座侧面预留插座

Furnishing articles and sculpture process requirements

摆件及雕塑工艺要求

1、Art as the main theme, style, the main form of expression, need to have a strong visual impact

艺术品作为主题思想、风格的主要表现形式, 需要具有很强的视觉冲击力。

2、First, the designer confirmed the design, selected processing materials.

首先草图, 效果图由设计师确认, 选定加工材料。

3、According to the site, to determine the size of the sculpture. 根据现场, 图纸确定雕塑、摆件大小尺寸。

4、Make mud draft, foam model, confirm the overall effect. 制作泥稿、泡沫模型, 确认整体效果。

5、Indoor metal art material thickness shall not be less than 1.5 mm, resin thickness shall not be less than 3mm.

金属艺术品材料厚度室内不得低于1.5mm, 树脂厚度不得低于3mm。

6、Resin artwork surface color guarantee does not fade. 树脂艺术品表面颜色保证不褪色。

7、Seamless metal joints, bending polished smooth. 金属接缝处无缝隙, 折弯处打磨光滑。

8、摆件雕塑必须牢固、稳定、安全、与灯光很好结合。

9、石材基座必须做好加固, 以防碰撞引起倒掉。

10、落地安放艺术品要稳、安全。

平面图

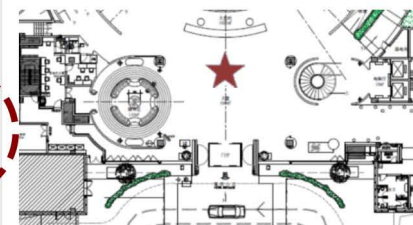

- 注: 1、实际艺术品以中标单位现场核实具体尺寸数量再深化为准;
2、此点位需灯光照亮, 需灯光顾问配合处理;
3、此点位地面需预留电源位置;
4、此点位艺术吊饰顶部天花需做双层18mm木工板加固。

图片仅供参考, 以最终效果为准。

果实的演变: 茧丝→具体形态

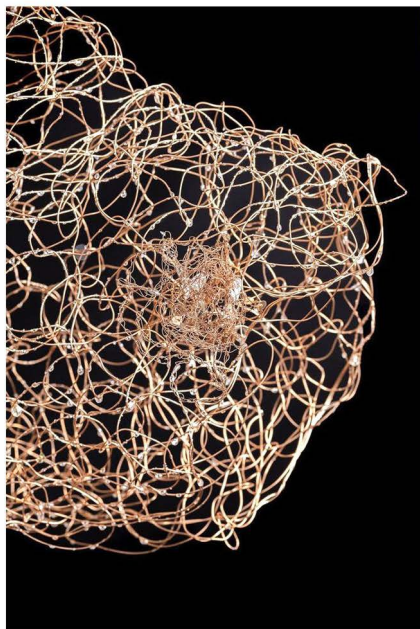

水晶种子造型吊饰

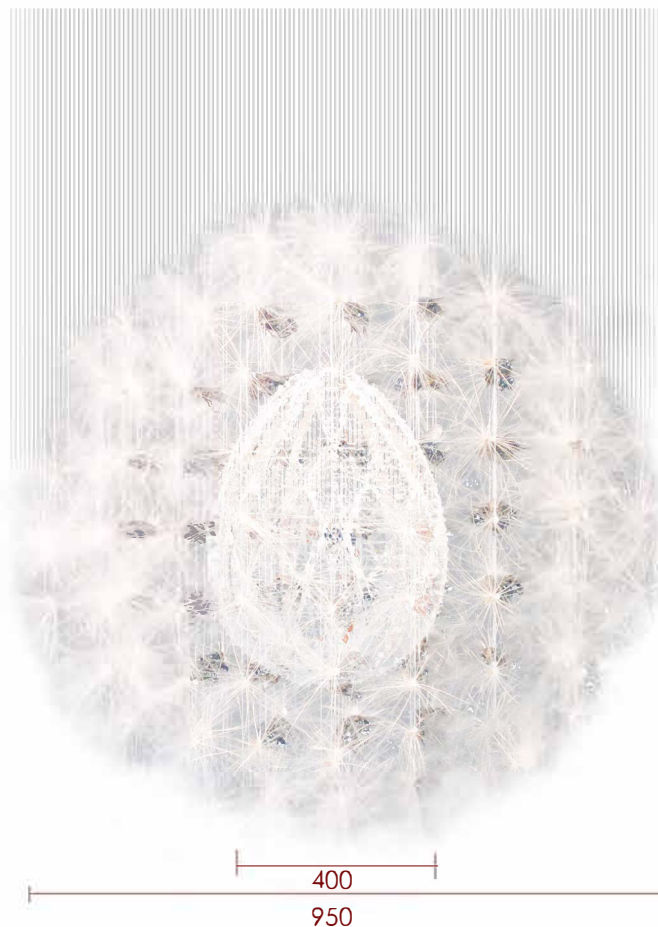

540

950

- 注: 1、实际艺术品以中标单位现场核实具体尺寸数量再深化为准;
2、此点位需灯光照亮, 需灯光顾问配合处理;
3、此点位地面需预留电源位置;
4、此点位艺术吊饰顶部天花需做双层18mm木工板加固。

Furnishing articles and sculpture process requirements

摆件及雕塑工艺要求

- 1、Art as the main theme, style, the main form of expression, need to have a strong visual impact
艺术品作为主题思想、风格的主要表现形式, 需要具有很强的视觉冲击力。
- 2、First, the designer confirmed the design, selected processing materials.
首先草图, 效果图由设计师确认, 选定加工材料。
- 3、According to the site, to determine the size of the sculpture.
根据现场, 图纸确定雕塑、摆件大小尺寸。
- 4、Make mud draft, foam model, confirm the overall effect.
制作泥稿、泡沫模型, 确认整体效果。
- 5、Indoor metal art material thickness shall not be less than 1.5 mm, resin thickness shall not be less than 3mm.
金属艺术品材料壁厚室内不得低于1.5mm, 树脂壁厚度不得低于3mm。
- 6、Resin artwork surface color guarantee does not fade.
树脂艺术品表面颜色保证不褪色。
- 7、Seamless metal joints, bending polished smooth.
金属接缝处无缝隙, 折弯处打磨光滑。
- 8、摆件雕塑必须牢固、稳定、安全、与灯光很好结合。
- 9、石材基座必须做好加重加固, 以防碰撞引起倒塌。
- 10、落地安放艺术品要稳、安全。

平面图

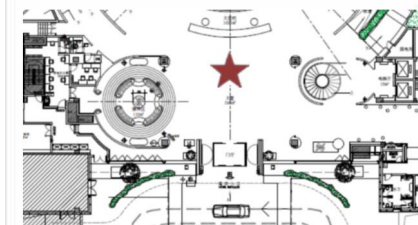

图片仅供参考, 以最终效果为准。

Project 项目名称: 杭州天目山格芮精选希尔顿酒店 Serial number 项目编号: 1F-LO-01

Area 区域: 一层大堂

Number 数量: 1组

Material 材质: 叶片水晶吊饰+中央水晶种子吊饰
+镜面波纹黑色石材底座+安装配件

Size 尺寸: 吊饰: W3000*D3000*H2500, 底座: W3000*D3000*H300

Process description 工艺说明:

白天效果:



夜晚效果:

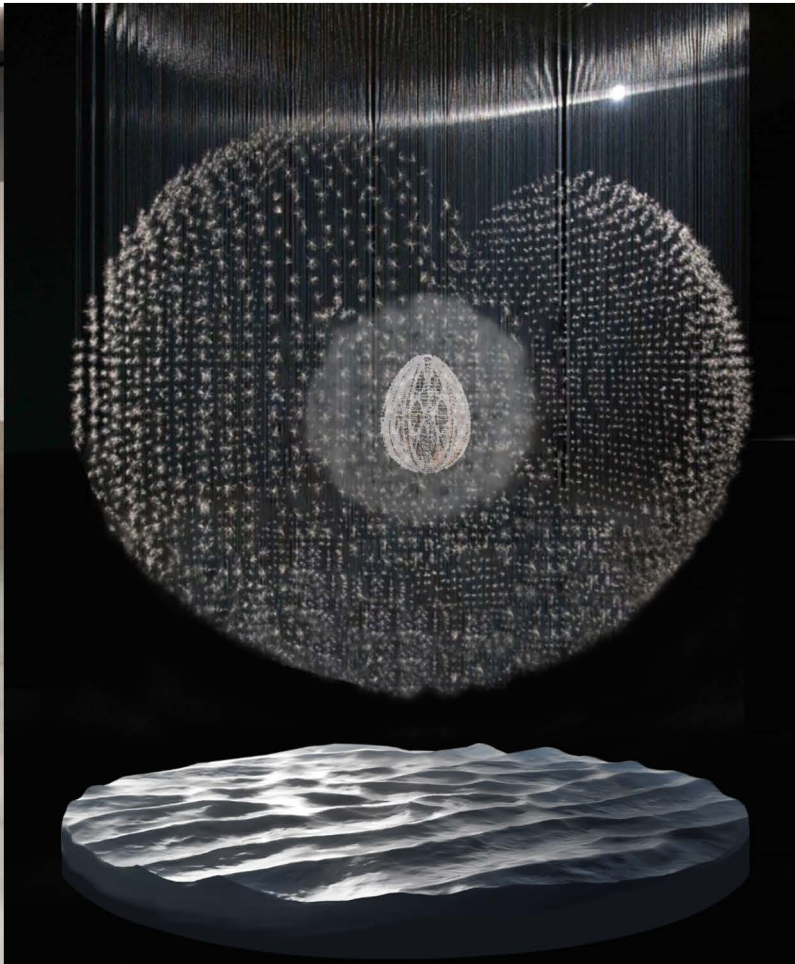

注: 1、实际艺术品以中标单位现场核实具体尺寸数量再深化为准;
2、此点位需灯光照亮, 需灯光顾问配合处理;
3、此点位地面需预留电源位置;
4、此点位艺术吊饰顶部天花需做双层18mm木工板加固。

Furnishing articles and sculpture process requirements

摆件及雕塑工艺要求

1、 Art as the main theme, style, the main form of expression, need to have a strong visual impact

艺术品作为主题思想、风格的主要表现形式, 需要具有很强的视觉冲击力。

2、 First, the designer confirmed the design, selected processing materials.

首先草图, 效果图由设计师确认, 选定加工材料。

3、 According to the site, to determine the size of the sculpture.

根据现场, 图纸确定雕塑、摆件大小尺寸。

4、 Make mud draft, foam model, confirm the overall effect.

制作泥稿、泡沫模型, 确认整体效果。

5、 Indoor metal art material thickness shall not be less than 1.5 mm, resin thickness shall not be less than 3mm.

金属艺术品材料壁厚室内不得低于1.5mm, 树脂壁厚度不得低于3mm。

6、 Resin artwork surface color guarantee does not fade.

树脂艺术品表面颜色保证不褪色。

7、 Seamless metal joints, bending polished smooth.

金属接缝处无缝隙, 折弯处打磨光滑。

8、 摆件雕塑必须牢固、稳定、安全、与灯光很好结合。

9、 石材基座必须做好加重加固, 以防碰撞引起倒塌。

10、 落地安放艺术品要稳、安全。

平面图

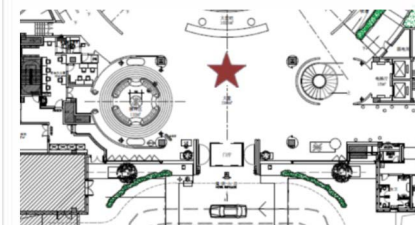

图片仅供参考, 以最终效果为准。

艺术品天花上方需灯光照亮, 需灯光顾问配合处理。

吊饰尺寸: W3000*D3000*H2500, 吊线高度约H900

平面定位尺寸:

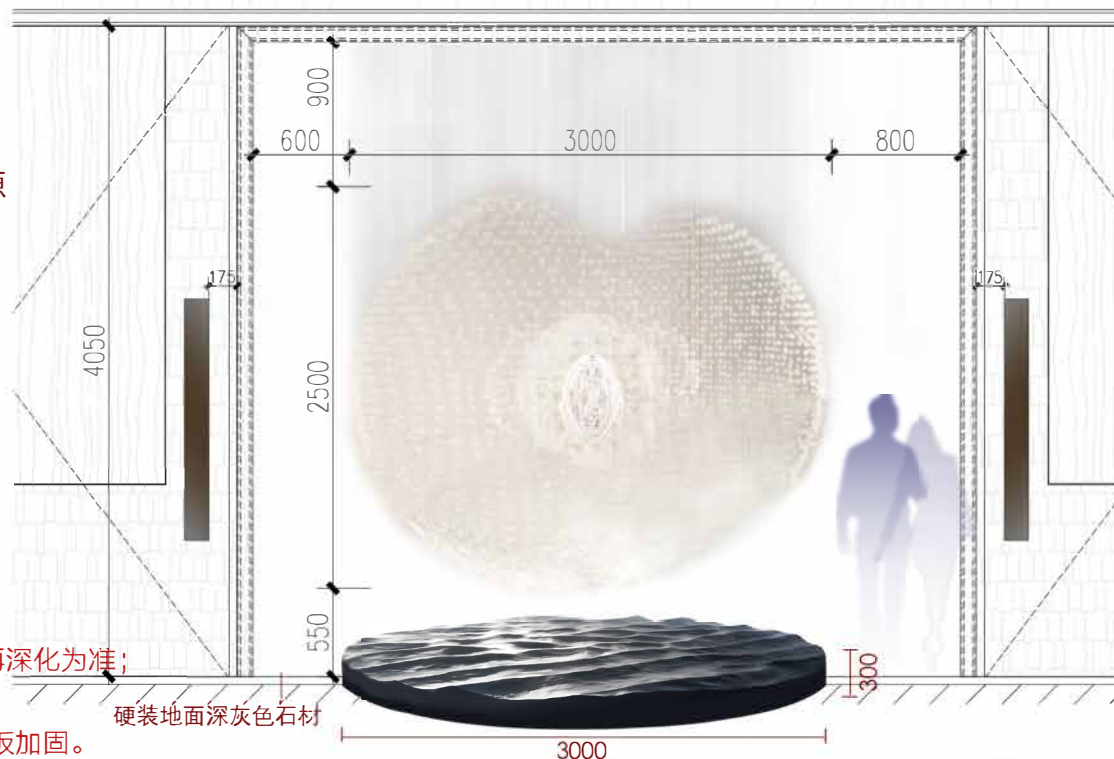
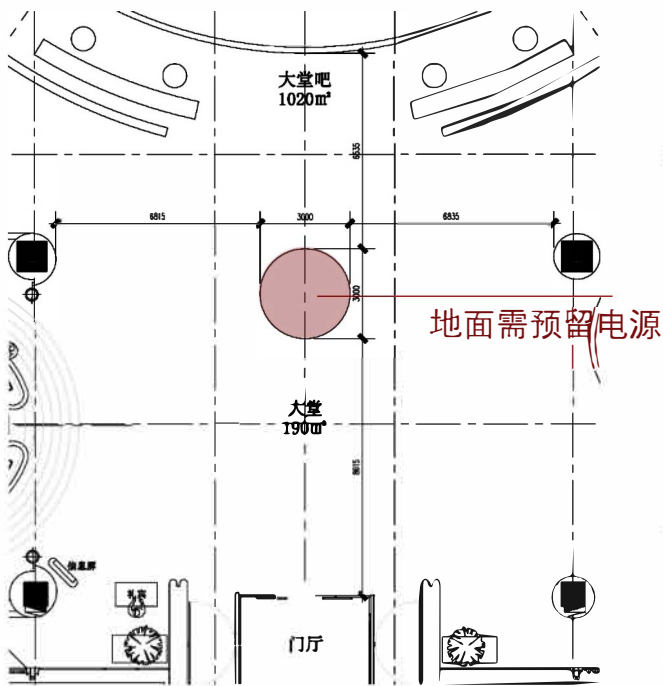

Furnishing articles and sculpture process requirements

摆件及雕塑工艺要求

1、 Art as the main theme, style, the main form of expression, need to have a strong visual impact

艺术品作为主题思想、风格的主要表现形式, 需要具有很强的视觉冲击力。

2、 First, the designer confirmed the design, selected processing materials.

首先草图, 效果图由设计师确认, 选定加工材料。

3、 According to the site, to determine the size of the sculpture. 根据现场, 图纸确定雕塑、摆件大小尺寸。

4、 Make mud draft, foam model, confirm the overall effect. 制作泥稿、泡沫模型, 确认整体效果。

5、 Indoor metal art material thickness shall not be less than 1.5 mm, resin thickness shall not be less than 3mm.

金属艺术品材料厚度室内不得低于1.5mm, 树脂壁厚厚度不得低于3mm。

6、 Resin artwork surface color guarantee does not fade. 树脂艺术品表面颜色保证不褪色。

7、 Seamless metal joints, bending polished smooth. 金属接缝处无缝隙, 折弯处打磨光滑。

8、 摆件雕塑必须牢固、稳定、安全、与灯光很好结合。

9、 石材基座必须做好加固, 以防碰撞引起倒塌。

10、 落地安放艺术品要稳、安全。

平面图

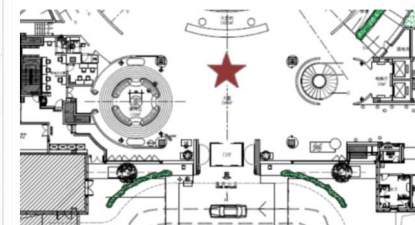

图片仅供参考, 以最终效果为准。

- 注: 1、实际艺术品以中标单位现场核实具体尺寸数量再深化为准;
2、此点位需灯光照亮, 需灯光顾问配合处理;
3、此点位地面需预留电源位置;
4、此点位艺术吊饰顶部天花需做双层18mm木工板加固。

THE WALL OF THE FIRST FLOOR LOBBY RAMP

一层大堂坡道处墙面

天目山国家级自然保护区是一个以保护生物多样性和森林生态系统为重点的野生植物类型国家自然保护区，区内生物多样性突出，生物资源极其丰富，取珍稀植物的种子为设计元素，以嵌入树脂的形式展现物种基因库”和“文化遗产宝库”

TIANMU MOUNTAIN NATIONAL NATURE RESERVE IS A WILD PLANT TYPE NATIONAL NATURE RESERVE FOCUSING ON PROTECTING BIODIVERSITY AND FOREST ECOSYSTEMS.

THE AREA HAS OUTSTANDING BIODIVERSITY AND EXTREMELY RICH BIOLOGICAL RESOURCES. TAKING 12 KINDS OF RARE PLANTS FROM TIANMU MOUNTAIN AS DESIGN ELEMENTS, THE SPECIES GENE LIBRARY AND CULTURAL HERITAGE TREASURE HOUSE ARE DISPLAYED IN THE FORM OF EMBEDDED RESIN.



Project 项目名称: 杭州天目山格芮精选希尔顿酒店 Serial number 项目编号: 1F-LO-02

Material 材质: 柱体树脂内嵌果实

Process description 工艺说明:

Area 区域: 一层大堂

Number 数量: 13件

Size 尺寸: $\phi 250 \times H300$



300

250

种子尺寸约: H10

材质示意:



局部示意:



无CAD立面图纸, SU模型示意:

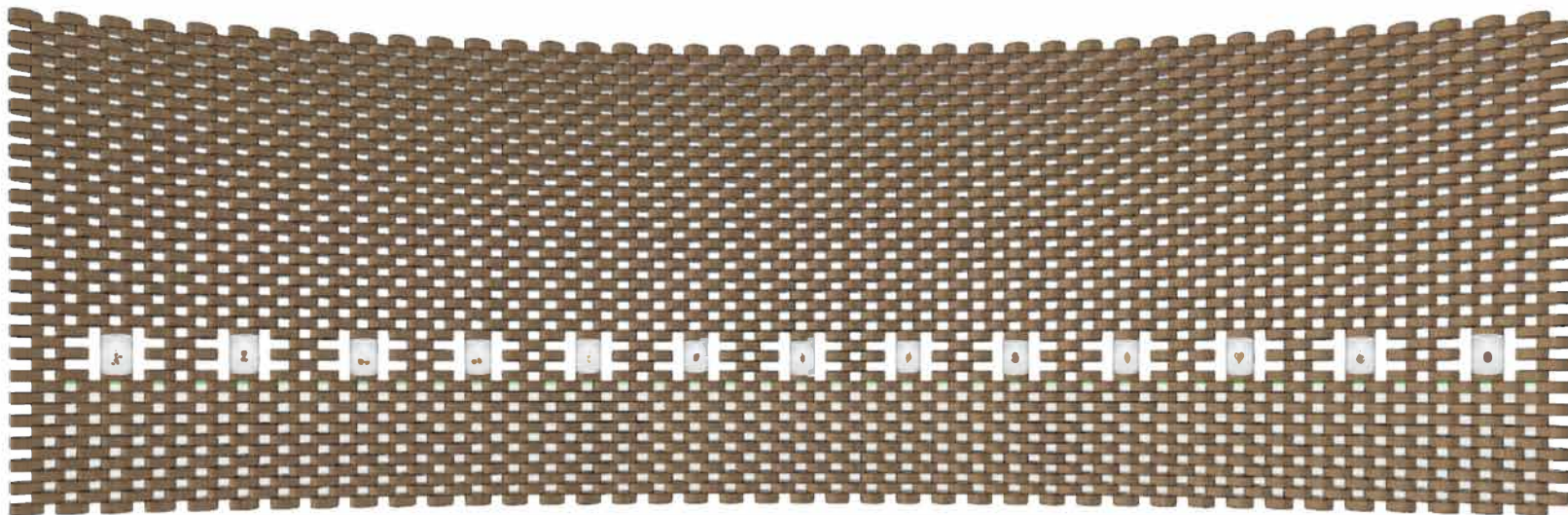

Furnishing articles and sculpture process requirements

摆件及雕塑工艺要求

1、Art as the main theme, style, the main form of expression, need to have a strong visual impact

艺术品作为主题思想、风格的主要表现形式, 需要具有很强的视觉冲击力。

2、First, the designer confirmed the design, selected processing materials

首先草图, 效果图由设计师确认, 选定加工材料。

3、According to the site, to determine the size of the sculpture

根据现场, 图纸确定雕塑、摆件大小尺寸。

4、Make mud draft, foam model, confirm the overall effect

制作泥稿、泡沫模型, 确认整体效果。

5、Indoor metal art material thickness shall not be less than 1.5 mm, resin thickness shall not be less than 3mm

金属艺术品材料厚度室内不得低于1.5mm, 树脂厚度不得低于3mm。

6、Resin artwork surface color guarantee does not fade

树脂艺术品表面颜色保证不褪色。

7、Seamless metal joints, bending polished smooth

金属接缝处无缝隙, 折弯处打磨光滑。

8、摆件雕塑必须牢固、稳定、安全、与灯光很好结合。

9、石材基座必须做好加重加固, 以防碰撞引起倒掉。

10、落地安放艺术品要稳、安全。

平面图



图片仅供参考, 以最终效果为准。

注: 1、实际艺术品以中标单位现场核实具体尺寸数量再深化为准;
2、此点位需灯光照亮, 需灯光顾问配合处理。

Project 项目名称: 杭州天目山格芮精选希尔顿酒店 Serial number 项目编号: 1F-LO-02

Material 材质: 柱体树脂内嵌果实

Process description 工艺说明:

区域: 一层大堂

Number

数量: 13件

Size

尺寸: $\phi 250 * H300$



种子尺寸约: H10

300

250

材质示意:



局部示意:



无CAD立面图纸, SU模型示意:

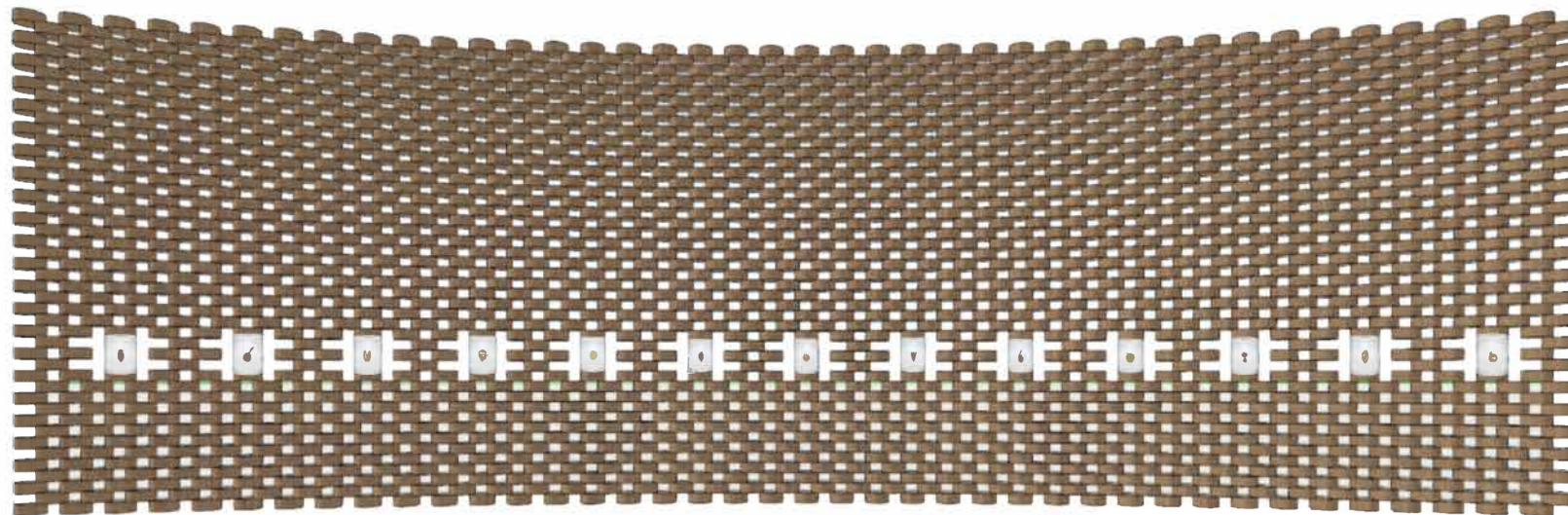

Furnishing articles and sculpture process requirements

摆件及雕塑工艺要求

1、 Art as the main theme, style, the main form of expression, need to have a strong visual impact

艺术品作为主题思想、风格的主要表现形式, 需要具有很强的视觉冲击力。

2、 First, the designer confirmed the design, selected processing materials.

首先草图, 效果图由设计师确认, 选定加工材料。

3、 According to the site, to determine the size of the sculpture. 根据现场, 图纸确定雕塑、摆件大小尺寸。

4、 Make mud draft, foam model, confirm the overall effect. 制作泥稿、泡沫模型, 确认整体效果。

5、 Indoor metal art material thickness shall not be less than 1.5 mm, resin thickness shall not be less than 3mm.

金属艺术品材料厚度室内不得低于1.5mm, 树脂厚度不得低于3mm。

6、 Resin artwork surface color guarantee does not fade. 树脂艺术品表面颜色保证不褪色。

7、 Seamless metal joints, bending polished smooth. 金属接缝处无缝隙, 折弯处打磨光滑。

8、 摆件雕塑必须牢固、稳定、安全、与灯光很好结合。

9、 石材基座必须做好加重加固, 以防碰撞引起倒塌。

10、 落地安放艺术品要稳、安全。

平面图



图片仅供参考, 以最终效果为准。

注: 1、实际艺术品以中标单位现场核实具体尺寸数量再深化为准;
2、此点位需灯光照亮, 需灯光顾问配合处理。

BACK TO NATURE

回归自然



大树宛如一部无声的史书，承载着时光的沉淀。
它们历经风吹日晒，在悠悠岁月中接受着风雨的磨砺和时间的雕琢。

见证了四季的更替，目睹了日月的轮回，在岁月的长河中，
静默而坚韧地伫立着，以其独特的姿态展示着大自然的鬼斧神工和无尽魅力，
让人不禁感叹时光的神奇与永恒。

THE BIG TREE IS LIKE A SILENT HISTORY BOOK, CARRYING THE PRECIPITATION OF TIME.
THEY HAVE EXPERIENCED WIND AND SUN, AND HAVE BEEN TEMPERED BY WIND AND RAIN AND SCULPTED BY TIME IN THE LONG YEARS.
WITNESSING THE CHANGING OF THE FOUR SEASONS AND THE REINCARNATION OF THE SUN AND THE MOON, IT STANDS SILENTLY AND TENACIOUSLY IN THE LONG RIVER OF TIME, DISPLAYING THE UNCANNY CRAFTSMANSHIP AND ENDLESS CHARM OF NATURE WITH ITS UNIQUE POSTURE.
PEOPLE CAN'T HELP BUT SIGH AT THE MAGIC AND ETERNITY OF TIME.

SU模型示意:

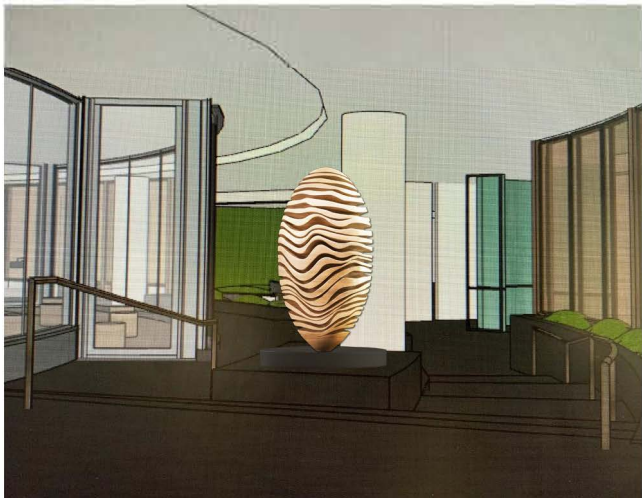

悄然 在年轮之上蔓延、生长，似是 为时光的印记披上了一层 生机勃勃的华服。每一片绿叶 都在舒展，每一处苔藓 都在呼吸，它们共同奏响了一曲 生态的乐章。
Quietly spreading and growing on the annual rings, it seems to have draped a layer of vibrant clothing over the imprints of time. Every green leaf is stretching, every moss is breathing, and together they play a melody of ecology.

平面布局:

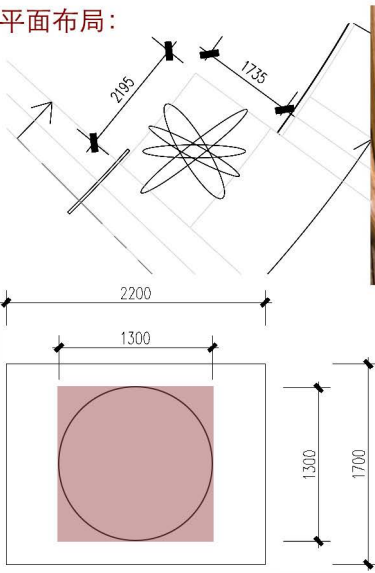

细节展示

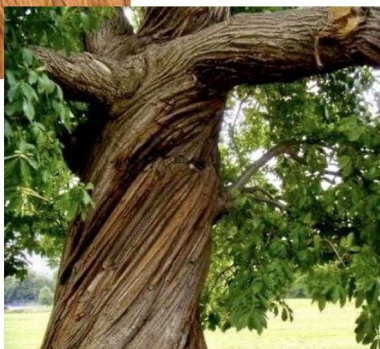

灵感来源: 生态之韵



Furnishing articles and sculpture process requirements

摆件及雕塑工艺要求



- 1、Art as the main theme, style, the main form of expression, need to have a strong visual impact
艺术品作为主题思想、风格的主要表现形式，需要具有极强的视觉冲击力。
- 2、First, the designer confirmed the design, selected processing materials.
首先草图，效果图由设计师确认，选定加工材料。
According to the site, to determine the size of the sculpture. 根据现场，图纸确定雕塑、摆件大小尺寸。
- 4、Make mud draft, foam model, confirm the overall effect. 制作泥稿、泡沫模型，确认整体效果。
Lead metal art material thickness shall not be less than 1.5 mm, resin thickness shall not be less than 3mm.
金属艺术品材料壁厚室内不得低于1.5mm,树脂壁厚度不得低于3mm。
Resin artwork surface color guarantee does not fade. 树脂艺术品表面颜色保证不褪色。
- 7、Seamless metal joints, bending polished smooth. 金属接缝处无缝隙，折弯处打磨光滑。
- 8、摆件雕塑必须牢固、稳定、安全、与灯光很好结合。
- 9、石材基座必须做好加重加固，以防碰撞引起倒掉。
- 10、落地安放艺术品要稳、安全。

平面图

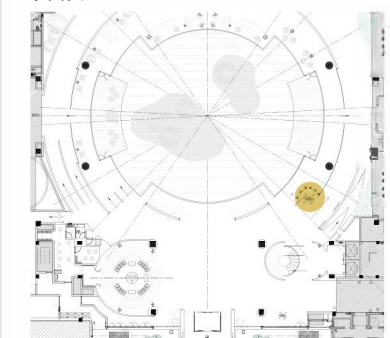

图片仅供参考，以最终效果为准。

注：1、实际艺术品以中标单位现场核实具体尺寸数量再深化为准；
2、此点位需灯光照亮。

Project 项目名称: 杭州天目山格芮精选希尔顿酒店 Serial number 项目编号: 1F-LB-04

Material 材质: 木质雕刻造型雕塑+黑色金属底座

Process description 工艺说明:

Area 区域: 一层大堂吧

Number 数量: 1件

Size 尺寸: W460*D270*H580



460

家具根据施工图尺寸为:
W1800*D500



Furnishing articles and sculpture process requirements

摆件及雕塑工艺要求

1、 Art as the main theme, style, the main form of expression, need to have a strong visual impact

艺术品作为主题思想、风格的主要表现形式, 需要具有很强的视觉冲击力。

2、 First, the designer confirmed the design, selected processing materials.

首先草图, 效果图由设计师确认, 选定加工材料。

3、 According to the site, to determine the size of the sculpture. 根据现场, 图纸确定雕塑、摆件大小尺寸。

4、 Make mud draft, foam model, confirm the overall effect. 制作泥稿、泡沫模型, 确认整体效果。

5、 Indoor metal art material thickness shall not be less than 1.5 mm, resin thickness shall not be less than 3mm.

金属艺术品材料壁厚室内不得低于1.5mm, 树脂壁厚不得低于3mm。

6、 Resin artwork surface color guarantee does not fade. 树脂艺术品表面颜色保证不褪色。

7、 Seamless metal joints, bending polished smooth. 金属接缝处无缝隙, 折弯处打磨光滑。

8、 摆件雕塑必须牢固、稳定、安全、与灯光很好结合。

9、 石材基座必须做好加重加固, 以防碰撞引起倒掉。

10、 落地安放艺术品要稳、安全。

平面图

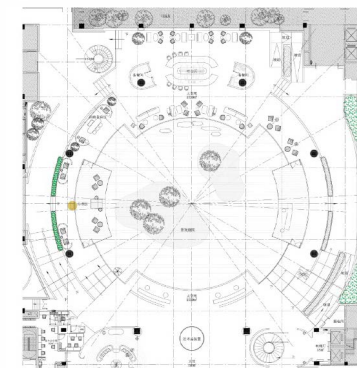

图片仅供参考, 以最终效果为准。

注:

1、 实际艺术品以中标单位现场核实具体尺寸数量再深化为准;

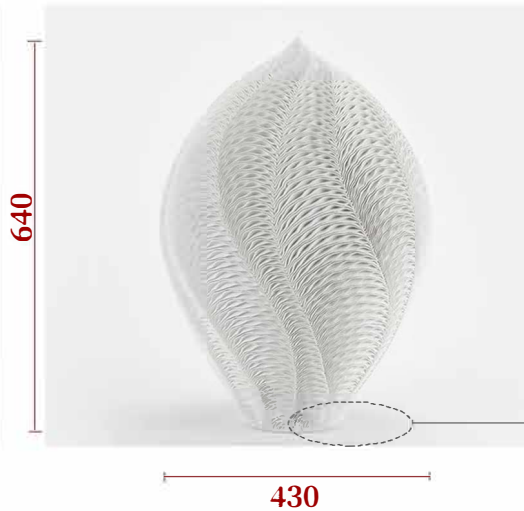

跳刀雕刻纹理

摆件底部打胶固定



家具根据施工图尺寸为W1800*D500

注: 1、实际艺术品以中标单位现场核实具体尺寸数量再深化为准;

Furnishing articles and sculpture process requirements

摆件及雕塑工艺要求

- 1、 Art as the main theme, style, the main form of expression, need to have a strong visual impact
艺术品作为主题思想、风格的主要表现形式, 需要具有很强的视觉冲击力。
- 2、 First, the designer confirmed the design, selected processing materials.
首先草图, 效果图由设计师确认, 选定加工材料。
- 3、 According to the site, to determine the size of the sculpture.
根据现场, 图纸确定雕塑、摆件大小尺寸。
- 4、 Make mud draft, foam model, confirm the overall effect.
制作泥稿、泡沫模型, 确认整体效果。
- 5、 Indoor metal art material thickness shall not be less than 1.5 mm, resin thickness shall not be less than 3mm.
金属艺术品材料壁厚室内不得低于1.5mm,树脂壁厚不得低于3mm。
- 6、 Resin artwork surface color guarantee does not fade.
树脂艺术品表面颜色保证不褪色。
- 7、 Seamless metal joints, bending polished smooth.
金属接缝处无缝隙, 折弯处打磨光滑。
- 8、 摆件雕塑必须牢固、稳定、安全、与灯光很好结合。
- 9、 石材基座必须做好加重加固, 以防碰撞引起倒掉。
- 10、 落地安放艺术品要稳、安全。

平面图



图片仅供参考, 以最终效果为准。

Project 项目名称: 杭州天目山格芮精选希尔顿酒店 Serial number 项目编号: 1F-LB-06

Material 材质: 永生苔藓, 绿植, 灰石, 雪浪石, 白沙砾

Process description 工艺说明:

区域: 一层大堂吧

Number

数量: 1组

Size

尺寸: 区域尺寸约: W5800*D1150



白沙砾



雪浪石



永生苔藓, 绿植



区域尺寸约: W5800*D1150

注: 白沙砾底部打胶固定

注:

- 1、实际艺术品以中标单位现场核具体尺寸数量再深化为准;
- 2、后期绿植方案由专业的绿植公司进行深化为准!

Furnishing articles and sculpture process requirements

摆件及雕塑工艺要求

1、 Art as the main theme, style, the main form of expression, need to have a strong visual impact

艺术品作为主题思想、风格的主要表现形式, 需要具有很强的视觉冲击力。

2、 First, the designer confirmed the design, selected processing materials.

首先草图, 效果图由设计师确认, 选定加工材料。

3、 According to the site, to determine the size of the sculpture. 根据现场, 图纸确定雕塑、摆件大小尺寸。

4、 Make mud draft, foam model, confirm the overall effect. 制作泥稿、泡沫模型, 确认整体效果。

5、 Indoor metal art material thickness shall not be less than 1.5 mm, resin thickness shall not be less than 3mm.

金属艺术品材料厚度室内不得低于1.5mm, 树脂壁厚厚度不得低于3mm。

6、 Resin artwork surface color guarantee does not fade. 树脂艺术品表面颜色保证不褪色。

7、 Seamless metal joints, bending polished smooth. 金属接缝处无缝隙, 折弯处打磨光滑。

8、 摆件雕塑必须牢固、稳定、安全、与灯光很好结合。

9、 石材基座必须做好加重加固, 以防碰撞引起倒塌。

10、 落地安放艺术品要稳、安全。

平面图

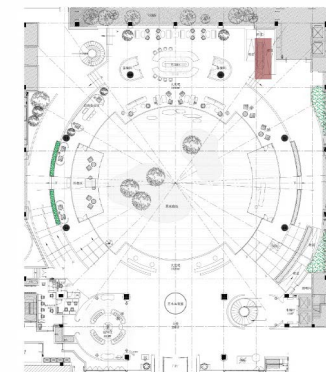

图片仅供参考, 以最终效果为准。

Project 项目名称: 杭州天目山格芮精选希尔顿酒店 Serial number 项目编号: 1F-LB-07

Material 材质: 永生苔藓, 绿植, 灰石, 雪浪石, 白沙砾

Process description 工艺说明:

区域: 一层大堂吧

Number

数量: 1组

Size

尺寸: 区域尺寸约: W5000*D9000



白沙砾



雪浪石



永生苔藓, 绿植



区域尺寸约: W5000*D9000

注: 白沙砾底部打胶固定

注:

- 1、实际艺术品以中标单位现场核实具体尺寸数量再深化为准;
- 2、后期绿植方案由专业的绿植公司进行深化为准!

Furnishing articles and sculpture process requirements

摆件及雕塑工艺要求

1、 Art as the main theme, style, the main form of expression, need to have a strong visual impact

艺术品作为主题思想、风格的主要表现形式, 需要具有很强的视觉冲击力。

2、 First, the designer confirmed the design, selected processing materials.

首先草图, 效果图由设计师确认, 选定加工材料。

3、 According to the site, to determine the size of the sculpture.

根据现场, 图纸确定雕塑、摆件大小尺寸。

4、 Make mud draft, foam model, confirm the overall effect.

制作泥稿、泡沫模型, 确认整体效果。

5、 Indoor metal art material thickness shall not be less than 1.5 mm, resin thickness shall not be less than 3mm.

金属艺术品材料厚度室内不得低于1.5mm, 树脂厚度不得低于3mm。

6、 Resin artwork surface color guarantee does not fade.

树脂艺术品表面颜色保证不褪色。

7、 Seamless metal joints, bending polished smooth.

金属接缝处无缝隙, 折弯处打磨光滑。

8、 摆件雕塑必须牢固、稳定、安全、与灯光很好结合。

9、 石材基座必须做好加重加固, 以防碰撞引起倒掉。

10、 落地安放艺术品要稳、安全。

平面图

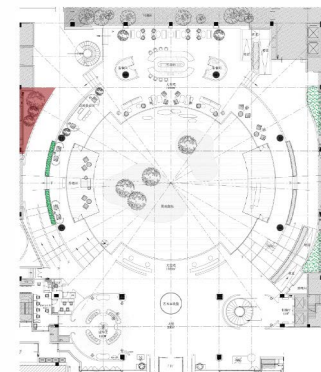

图片仅供参考, 以最终效果为准。



立面墙区域尺寸约: W4600*H3300



立面墙区域尺寸约: W4600*H3300

①



区域尺寸约: W3500*D9000

注: 白沙砾底部打胶固定

②



区域尺寸约: W3500*D9000

注:

- 1、实际艺术品以中标单位现场核实具体尺寸数量再深化为准;
- 2、后期绿植方案由专业的绿植公司进行深化为准!

Furnishing articles and sculpture process requirements

摆件及雕塑工艺要求

- 1、 Art as the main theme, style, the main form of expression, need to have a strong visual impact
艺术品作为主题思想、风格的主要表现形式, 需要具有很强的视觉冲击力。
- 2、 First, the designer confirmed the design, selected processing materials.
首先草图, 效果图由设计师确认, 选定加工材料。
- 3、 According to the site, to determine the size of the sculpture.
根据现场, 图纸确定雕塑、摆件大小尺寸。
- 4、 Make mud draft, foam model, confirm the overall effect.
制作泥稿、泡沫模型, 确认整体效果。
- 5、 Indoor metal art material thickness shall not be less than 1.5 mm, resin thickness shall not be less than 3mm.
金属艺术品材料壁厚室内不得低于1.5mm, 树脂壁厚度不得低于3mm。
树脂 artwork surface color guarantee does not fade.
树脂艺术品表面颜色保证不褪色。
- 6、 Seamless metal joints, bending polished smooth.
金属接缝处无缝隙, 折弯处打磨光滑。
- 8、 摆件雕塑必须牢固、稳定、安全、与灯光很好结合。
- 9、 石材基座必须做好加重加固, 以防碰撞引起倒掉。
- 10、 落地安放艺术品要稳、安全。

平面图

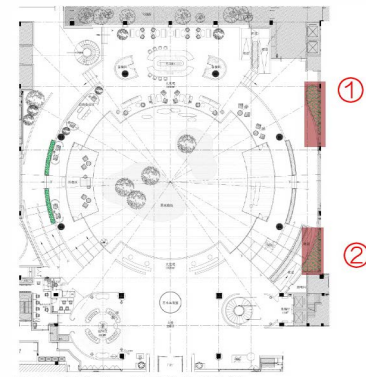

图片仅供参考, 以最终效果为准。

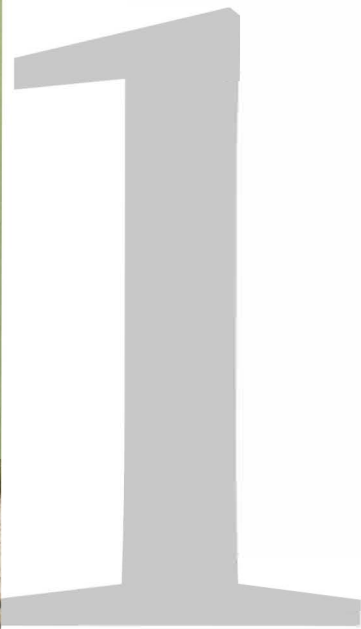

一层全日餐厅

ALL-DAY DINING RESTAURANT ON THE FIRST FLOOR

[花园秘境]

Garden Secret

ALL-DAY DINING RESTAURANT ON THE FIRST FLOOR

一层全日餐厅



花瓣从花蕾中缓缓舒展开来，每一片花瓣都轻薄如纱，柔软而富有弹性，它们相互依偎，层层叠叠，形成了一种独特的美感。

The petals unfold slowly from the buds. Each petal is as thin as gauze, soft and elastic. They nestle against each other, layers upon layers form a unique beauty.



一层全日餐厅效果图

RENDERING OF ALL-DAY DINING RESTAURANT ON THE FIRST FLOOR



一层全日餐厅效果图

RENDERING OF ALL-DAY DINING RESTAURANT ON THE FIRST FLOOR

ALL-DAY DINING RESTAURANT

步入全日餐厅，仿佛踏入了一个自然的梦幻之境。这里，以自然的空灵形态为灵感，每一处细节都散发着大自然的神韵。

取自大自然的艺术形态随处可见，似是将天目山的灵动画卷徐徐展开在眼前。如摇曳的树枝，轻盈而舒展，仿佛在微风中诉说着自然的故事，仿若闪烁的繁星，又似飘落的花瓣，营造出一种缥缈感，让人仿佛置身于云端之上，似有若无的光影交织，仿佛在提醒着人们，这是一个远离尘世喧嚣的世外桃源。

是一场与自然的对话，一次心灵的洗礼。在天目山的自然氛围包裹下，人们可以尽情享受这份宁静与美好，让身心在自然的怀抱中得到滋养和慰藉。

ENTERING THE ALL DAY RESTAURANT FEELS LIKE STEPPING INTO A NATURAL DREAMLAND. HERE, INSPIRED BY THE ETHEREAL FORM OF NATURE, EVERY DETAIL EXUDES THE CHARM OF NATURE. ARTISTIC FORMS TAKEN FROM NATURE CAN BE SEEN EVERYWHERE, AS IF UNFOLDING THE DYNAMIC PAINTING OF TIANMU MOUNTAIN SLOWLY BEFORE OUR EYES. LIKE SWAYING BRANCHES, LIGHT AND STRETCHED, AS IF TELLING THE STORY OF NATURE IN A GENTLE BREEZE, LIKE TWINKLING STARS, LIKE FALLING PETALS, IT CREATES A SENSE OF AMBIGUITY, MAKING PEOPLE FEEL AS IF THEY ARE ON TOP OF CLOUDS, INTERWEAVING LIGHT AND SHADOW THAT SEEM ELUSIVE, IT SEEMS TO REMIND PEOPLE THAT THIS IS A PARADISE AWAY FROM THE HUSTLE AND BUSTLE OF THE WORLD. IT IS A DIALOGUE WITH NATURE, A BAPTISM OF THE SOUL. UNDER THE NATURAL ATMOSPHERE OF TIANMU MOUNTAIN, PEOPLE CAN FULLY ENJOY THIS TRANQUILITY AND BEAUTY, ALLOWING THEIR BODIES AND MINDS TO BE NOURISHED AND COMFORTED IN THE EMBRACE OF NATURE.

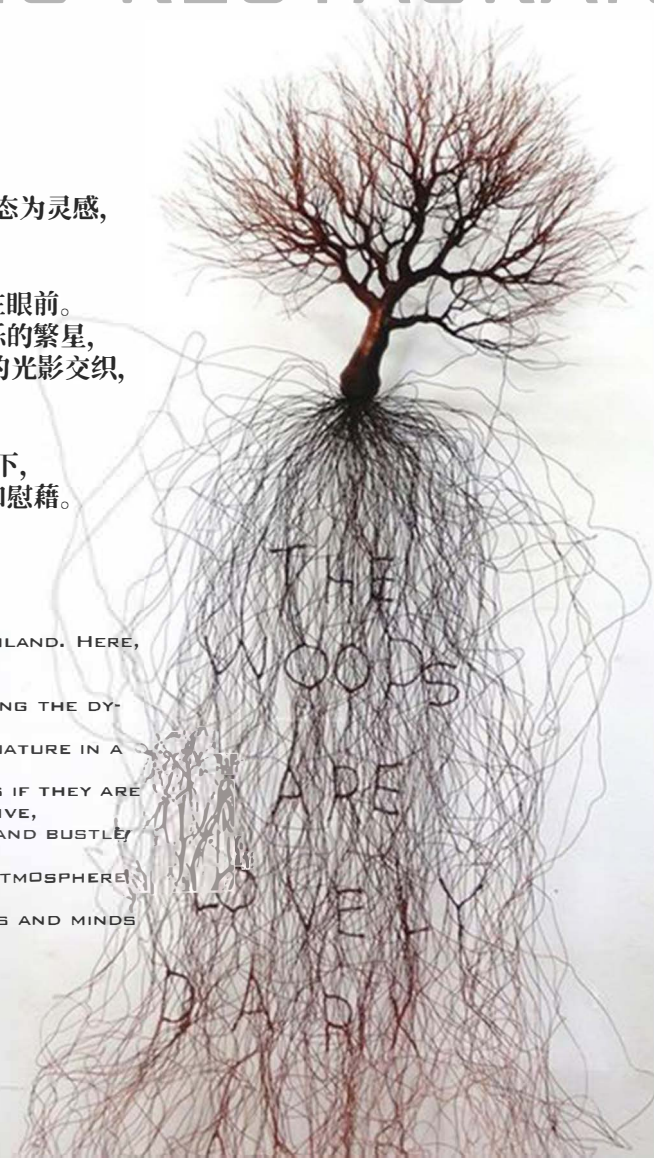

THE
WOODS
ARE
SO
LOVELY
DARLING



以自然界的天然树木为载体，犹如大地的支柱，坚实而沉稳。树枝，这大自然的灵动线条，以各种奇妙的形状排列组合在一起。有的相互交织，似在编织着自然的密语；有的蜿蜒伸展，仿佛要触摸天空的高远。

黑色抽象印象派的吊饰，如神秘的音符，在空气中摇曳舞动。它们与树枝相互映衬，增添了一抹深邃而神秘的色彩。那黑色，既有着夜的静谧，又蕴含着无尽的想象空间。仿佛是大自然在黑夜中的沉思，又似是艺术家用画笔勾勒出的奇幻梦境。

这组艺术装置，以自然为生，又孕育着自然。它是自然与艺术的完美融合，是对生命的礼赞，是对大自然无穷创造力的致敬。在这里，人们可以感受到自然的力量与美丽，也能领略到艺术的魅力与震撼。它如同一座连接现实与幻想的桥梁，引领人们走进一个充满诗意与奇幻的世界。

USING NATURAL TREES IN NATURE AS CARRIERS, LIKE PILLARS OF THE EARTH, SOLID AND STEADY. BRANCHES, THE DYNAMIC LINES OF NATURE, ARE ARRANGED AND COMBINED IN VARIOUS WONDERFUL SHAPES. SOME INTERTWINE WITH EACH OTHER, AS IF WEAVING NATURAL SECRETS; SOME STRETCH OUT IN A WINDING MANNER, AS IF TRYING TO TOUCH THE VASTNESS OF THE SKY.

THE BLACK ABSTRACT IMPRESSIONIST PENDANTS SWAY AND DANCE IN THE AIR LIKE MYSTERIOUS MUSICAL NOTES. THEY COMPLEMENT EACH OTHER WITH THE BRANCHES, ADDING A DEEP AND MYSTERIOUS COLOR. THAT BLACK COLOR EMBODIES BOTH THE TRANQUILITY OF THE NIGHT AND ENDLESS IMAGINATIVE SPACE. IT SEEMS LIKE THE CONTEMPLATION OF NATURE IN THE DARK NIGHT, OR LIKE A FANTASY DREAM OUTLINED BY AN ARTIST WITH A PAINTBRUSH.

THIS ART INSTALLATION MAKES A LIVING FROM NATURE AND NURTURES IT. IT IS A PERFECT FUSION OF NATURE AND ART, A TRIBUTE TO LIFE, AND A TRIBUTE TO THE INFINITE CREATIVITY OF NATURE. HERE, PEOPLE CAN FEEL THE POWER AND BEAUTY OF NATURE, AS WELL AS APPRECIATE THE CHARM AND SHOCK OF ART.

IT IS LIKE A BRIDGE CONNECTING REALITY AND FANTASY, LEADING PEOPLE INTO A WORLD FULL OF POETRY AND FANTASY.

材质细节

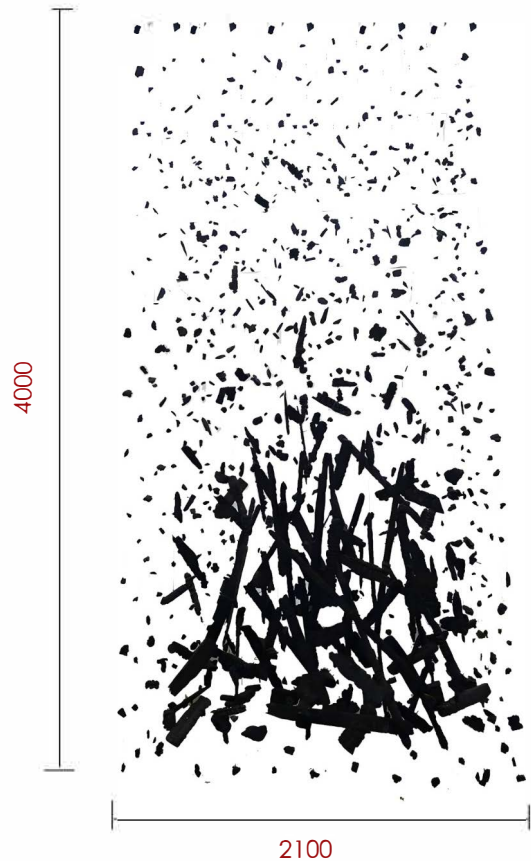

以自然界的天然树木为载体, 犹如大地的支柱, 坚实而沉稳。树枝, 这大自然的灵动线条, 以各种奇妙的形状排列组合在一起。有的相互交织, 似在编织着自然的密语; 有的蜿蜒伸展, 仿佛要触摸天空的高远。

Using natural trees in nature as carriers, like pillars of the earth, solid and steady. Branches, the dynamic lines of nature, are arranged and combined in various wonderful shapes. Some are intertwined with each other, it seems to be weaving natural secrets; Some stretch out in a winding manner, as if trying to touch the vastness of the sky.

注: 1、实际艺术品以中标单位现场核实具体尺寸数量再深化为准;
2、此点位需灯光照亮, 需灯光顾问配合处理;
3、此点位需天花顶部加固双层18mm木工板。

Furnishing articles and sculpture process requirements

摆件及雕塑工艺要求

1、 Art as the main theme, style, the main form of expression, need to have a strong visual impact

艺术品作为主题思想、风格的主要表现形式, 需要具有很强的视觉冲击力。

2、 First, the designer confirmed the design, selected processing materials.

首先草图, 效果图由设计师确认, 选定加工材料。

3、 According to the site, to determine the size of the sculpture. 根据现场, 图纸确定雕塑、摆件大小尺寸。

4、 Make mud draft, foam model, confirm the overall effect. 制作泥稿、泡沫模型, 确认整体效果。

5、 Indoor metal art material thickness shall not be less than 1.5 mm, resin thickness shall not be less than 3mm.

金属艺术品材料厚度室内不得低于1.5mm, 树脂厚度不得低于3mm。

6、 Resin artwork surface color guarantee does not fade. 树脂艺术品表面颜色保证不褪色。

7、 Seamless metal joints, bending polished smooth. 金属接缝处无缝隙, 折弯处打磨光滑。

8、 摆件雕塑必须牢固、稳定、安全、与灯光很好结合。

9、 石材基座必须做好加固加固, 以防碰撞引起倒掉。

10、 落地安放艺术品要稳、安全。

平面图



图片仅供参考, 以最终效果为准。

Project 项目名称: 杭州天目山格芮精选希尔顿酒店 Serial number 项目编号: 1F-ADD-01

Material 材质: 黑色肌理碳块+吊线

Process description 工艺说明:

区域: 一层全日餐厅

Number 数量: 1组

Size 尺寸: 区域尺寸: W2100*D2500*H4000.W2100*D2500*H4000



天花固定示意:

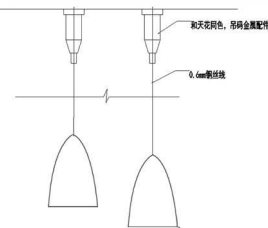

地面固定示意:



- 注: 1、实际艺术品以中标单位现场核实具体尺寸数量再深化为准;
 2、此点位需灯光照亮, 需灯光顾问配合处理;
 3、此点位需天花顶部加固双层18mm木工板。

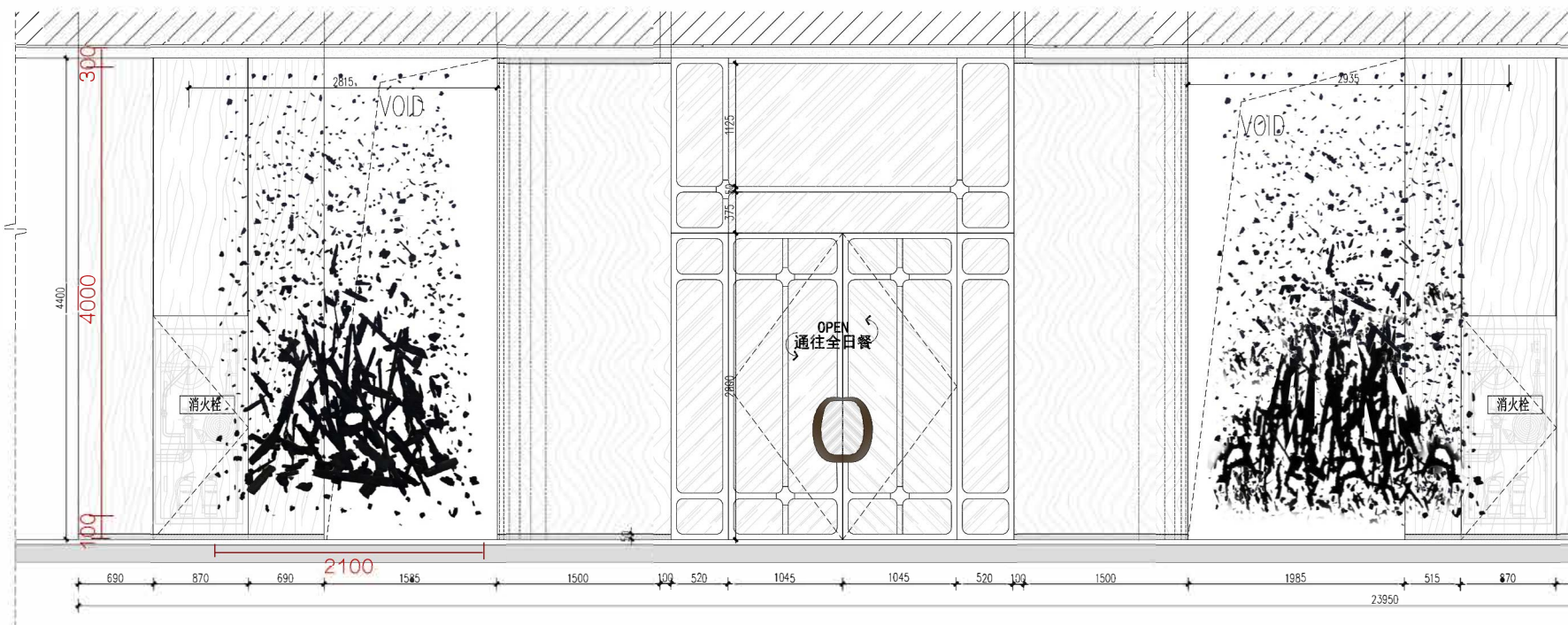

Furnishing articles and sculpture process requirements

摆件及雕塑工艺要求

1、 Art as the main theme, style, the main form of expression, need to have a strong visual impact

艺术品作为主题思想、风格的主要表现形式, 需要具有很强的视觉冲击力。

2、 First, the designer confirmed the design, selected processing materials.

首先草图, 效果图由设计师确认, 选定加工材料。

3、 According to the site, to determine the size of the sculpture.

根据现场, 图纸确定雕塑、摆件大小尺寸。

4、 Make mud draft, foam model, confirm the overall effect, 制作泥稿、泡沫模型, 确认整体效果。

5、 Indoor metal art material thickness shall not be less than 1.5 mm, resin thickness shall not be less than 3mm.

金属艺术品材料壁厚室内不得低于1.5mm, 树脂壁厚不得低于3mm。

6、 Resin artwork surface color guarantee does not fade, 树脂艺术品表面颜色保证不褪色。

7、 Seamless metal joints, bending polished smooth. 金属接缝处无缝隙, 折弯处打磨光滑。

8、 摆件雕塑必须牢固、稳定、安全、与灯光很好结合。

9、 石材基座必须做好加重加固, 以防碰撞引起倒掉。

10、 落地安放艺术品要稳、安全。

平面图



图片仅供参考, 以最终效果为准。

ALL-DAY DINING RESTAURANT



这件装置的灵感之源，是那隐匿于山林间、承载着生命密码的植物标本。以敏锐的感知力，捕捉到了叶脉与花蕊的独特肌理效果，宛如一场与自然的深情对话。

凭借精湛的技艺与无尽的巧思，选用柔韧的藤条为媒介，开启了一场将自然之美重现的奇妙之旅。藤条在手中翩翩起舞，它们相互交织、缠绕，编织出叶脉那细腻而清晰的纹理。那一根根藤条，仿佛被赋予了生命的力量，沿着叶脉的走向蜿蜒伸展，宛如时光的脉络，记录着自然的变迁与生命的轮回。

当阳光洒落在这件艺术装置上，藤条的纹理与光影相互交织，营造出如梦如幻的视觉效果。它仿佛是自然与艺术的完美融合，是对生命之美的崇高赞颂。它静静地伫立在那里，宛如一个无声的诗章，引领着人们走进那充满生机与美好的自然世界，感受着大自然的神奇魅力与无尽恩赐。

THE INSPIRATION FOR THIS DEVICE COMES FROM THE PLANT SPECIMENS HIDDEN IN THE MOUNTAINS AND FORESTS, CARRYING THE CODE OF LIFE. WITH KEEN PERCEPTION, THE UNIQUE TEXTURE EFFECT OF LEAF VEINS AND STAMENS WAS CAPTURED, LIKE A DEEP DIALOGUE WITH NATURE.

WITH EXQUISITE CRAFTSMANSHIP AND ENDLESS INGENUITY, USING FLEXIBLE RATTAN AS A MEDIUM, WE EMBARKED ON A WONDERFUL JOURNEY TO RECREATE THE BEAUTY OF NATURE. THE VINES DANCE GRACEFULLY IN THE HAND, INTERWEAVING AND INTER-TWINGING WITH EACH OTHER, WEAVING THE DELICATE AND CLEAR TEXTURE OF THE LEAF VEINS. THOSE VINES SEEM TO HAVE BEEN ENDOWED WITH THE POWER OF LIFE, WINDING AND STRETCHING ALONG THE VEINS OF THE VEINS, LIKE THE VEINS OF TIME, RECORDING THE CHANGES OF NATURE AND THE CYCLE OF LIFE.

WHEN SUNLIGHT FALLS ON THIS ART INSTALLATION, THE TEXTURE OF THE VINES INTERWEAVES WITH LIGHT AND SHADOW, CREATING A DREAMLIKE VISUAL EFFECT. IT SEEMS TO BE A PERFECT FUSION OF NATURE AND ART, A NOBLE PRAISE FOR THE BEAUTY OF LIFE. IT STANDS QUIETLY THERE, LIKE A SILENT POEM, LEADING PEOPLE INTO THE VIBRANT AND BEAUTIFUL NATURAL WORLD, FEELING THE MAGICAL CHARM AND ENDLESS GIFTS OF NATURE.

Project 项目名称: 杭州天目山格芮精选希尔顿酒店 Serial number 项目编号: 1F-ADD-02

区域: 一层全日餐厅

Number 数量: 1件

Material 材质: 手工编织藤编造型+结合局部金属丝缠绕+灰色木底板+黑色木框金属吊件

Size 尺寸: W2500*D50*H2500

Process description 工艺说明:

Furnishing articles and sculpture process requirements

摆件及雕塑工艺要求

1、 Art as the main theme, style, the main form of expression, need to have a strong visual impact

艺术品作为主题思想、风格的主要表现形式, 需要具有很强的视觉冲击力。

2、 First, the designer confirmed the design, selected processing materials.

首先草图, 效果图由设计师确认, 选定加工材料。

3、 According to the site, to determine the size of the sculpture. 根据现场, 图纸确定雕塑、摆件大小尺寸。

4、 Make mud draft, foam model, confirm the overall effect. 制作泥稿、泡沫模型, 确认整体效果。

5、 Indoor metal art material thickness shall not be less than 1.5 mm, resin thickness shall not be less than 3mm.

金属艺术品材料壁厚室内不得低于1.5mm, 树脂壁厚度不得低于3mm。

6、 Resin artwork surface color guarantee does not fade, 树脂艺术品表面颜色保证不褪色。

7、 Seamless metal joints, bending polished smooth. 金属接缝处无缝隙, 折弯处打磨光滑。

8、 摆件雕塑必须牢固、稳定、安全、与灯光很好结合。

9、 石材基座必须做好加重加固, 以防碰撞引起倒掉。

10、 落地安放艺术品要稳、安全。

平面图

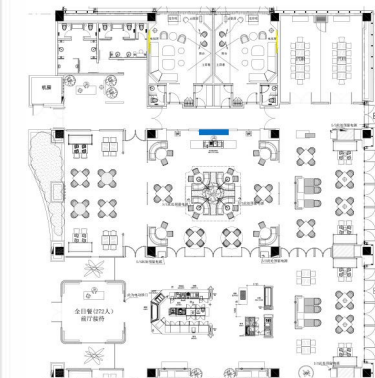

图片仅供参考, 以最终效果为准。

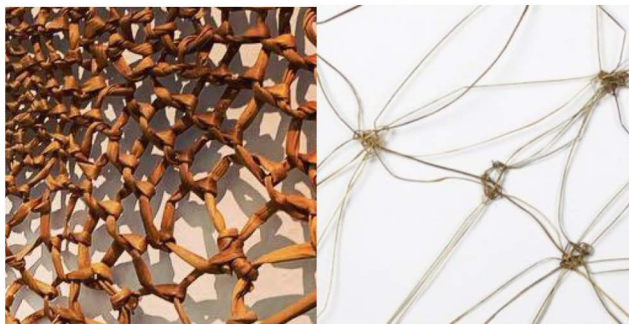

细节材质: 藤编结合金属丝

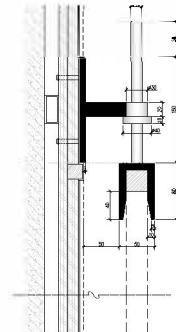

画框节点示意:

这件装置的灵感之源, 是那隐匿于山林间、承载着生命密码的植物标本, 以敏锐的感知力, 捕捉到了叶脉与花蕊的独特肌理效果, 宛如一场与自然的深情对话。

THE INSPIRATION FOR THIS DEVICE COMES FROM THE PLANT SPECIMENS HIDDEN IN THE MOUNTAINS AND FORESTS, CARRYING THE CODE OF LIFE. WITH KEEN PERCEPTION, IT CAPTURES THE UNIQUE TEXTURE EFFECT OF LEAF VEINS AND STAMENS, LIKE A DEEP DIALOGUE WITH NATURE.

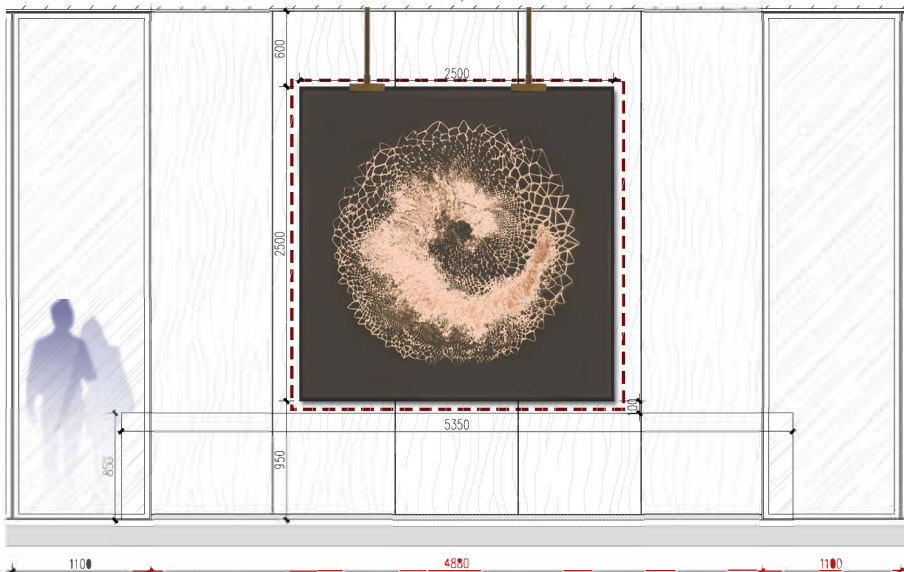

注: 1、实际艺术品以中标单位现场核实具体尺寸数量再深化为准;
2、此点位需灯光照亮, 需灯光顾问配合处理。
3、红框位置为加固区域, 需墙面加固厚度18mm木工板。



灵感来源: 植物标本

Project 项目名称: 杭州天目山格芮精选希尔顿酒店 Serial number 项目编号: 1F-ADD-03

Material 材质: 永生苔藓

Process description 工艺说明:

Area 区域: 一层全日餐厅

Number 数量: 3件

Size 尺寸: W750*H280,W900*H700,W450*H400

方案二:

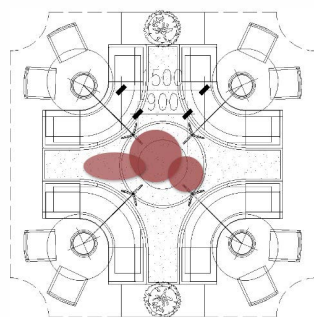

平面示意

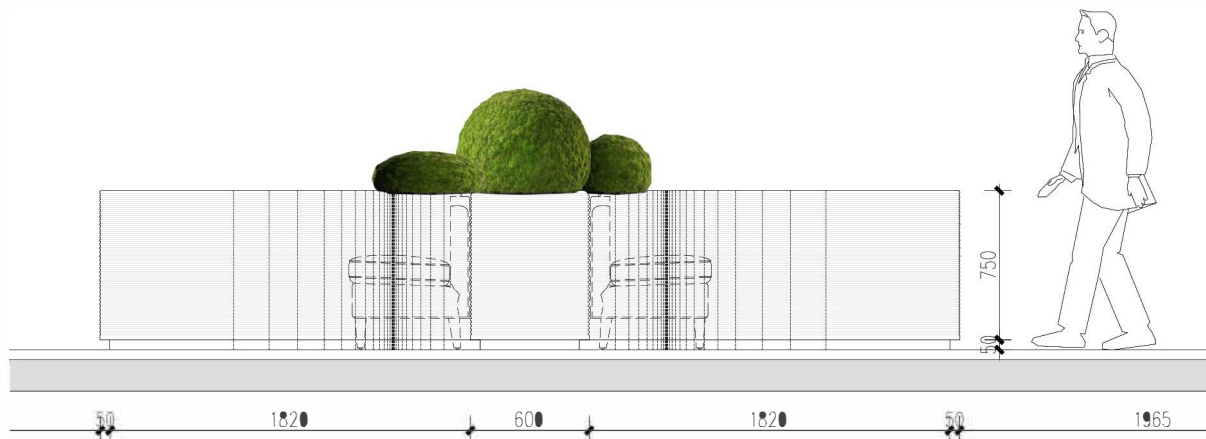

Furnishing articles and sculpture process requirements

摆件及雕塑工艺要求

1、 Art as the main theme, style, the main form of expression, need to have a strong visual impact

艺术品作为主题思想、风格的主要表现形式, 需要具有很强的视觉冲击力。

2、 First, the designer confirmed the design, selected processing materials.

首先草图, 效果图由设计师确认, 选定加工材料。

3、 According to the site, to determine the size of the sculpture. 根据现场, 图纸确定雕塑、摆件大小尺寸。

4、 Make mud draft, foam model, confirm the overall effect. 制作泥稿、泡沫模型, 确认整体效果。

5、 Indoor metal art material thickness shall not be less than 1.5 mm, resin thickness shall not be less than 3mm.

金属艺术品材料壁厚室内不得低于1.5mm,树脂壁厚不得低于3mm。

6、 Resin artwork surface color guarantee does not fade. 树脂艺术品表面颜色保证不褪色。

7、 Seamless metal joints, bending polished smooth. 金属接缝处无缝隙, 折弯处打磨光滑。

8、 摆件雕塑必须牢固、稳定、安全、与灯光很好结合。

9、 石材基座必须做好加重加固, 以防碰撞引起倒塌。

10、 落地安放艺术品要稳、安全。

平面图

台面: $\phi 1580$

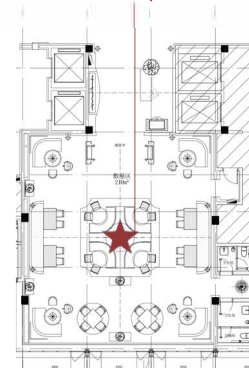

图片仅供参考, 以最终效果为准。

注: 1、实际艺术品以中标单位现场核实具体尺寸数量再深化为准;
2、此点位需灯光照亮, 需灯光顾问配合处理。

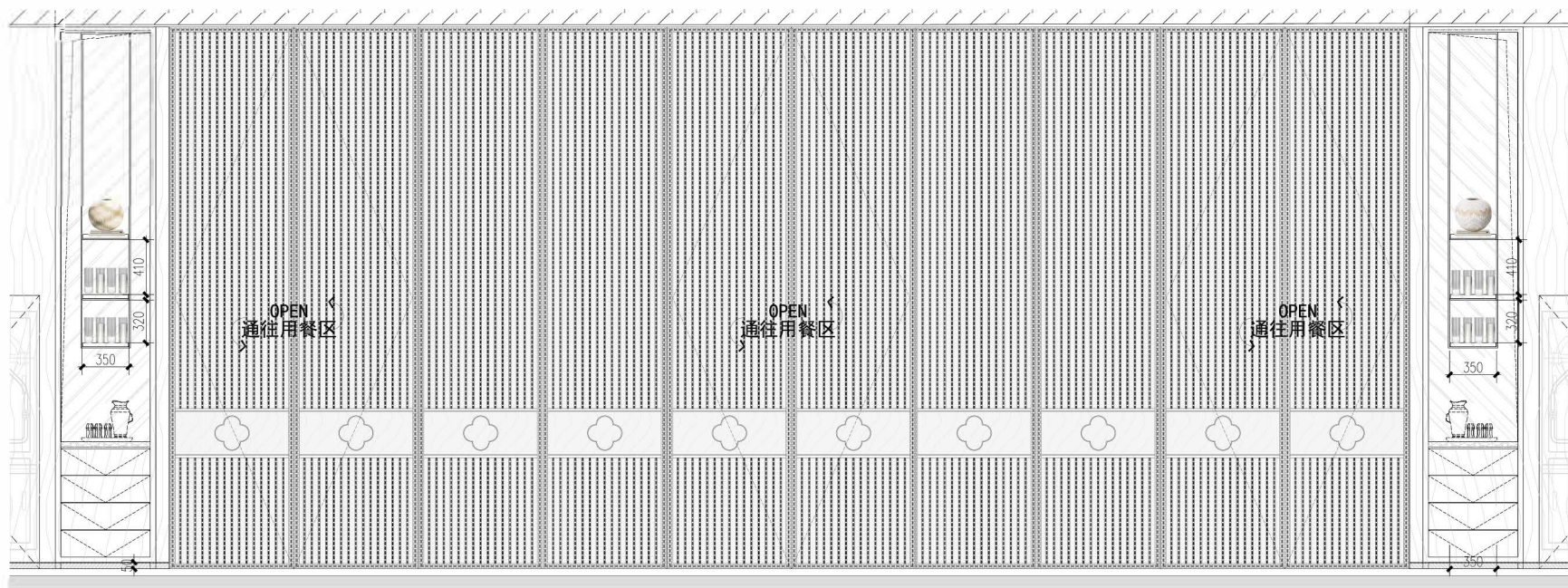

Furnishing articles and sculpture process requirements

摆件及雕塑工艺要求

1、 Art as the main theme, style, the main form of expression, need to have a strong visual impact

艺术品作为主题思想、风格的主要表现形式, 需要具有很强的视觉冲击力。

2、 First, the designer confirmed the design, selected processing materials.

首先草图, 效果图由设计师确认, 选定加工材料。

3、 According to the site, to determine the size of the sculpture. 根据现场, 图纸确定雕塑、摆件大小尺寸。

4、 Make mud draft, foam model, confirm the overall effect. 制作泥稿、泡沫模型, 确认整体效果。

5、 Indoor metal art material thickness shall not be less than 1.5 mm, resin thickness shall not be less than 3mm.

金属艺术品材料壁厚室内不得低于1.5mm, 树脂壁厚不得低于3mm。

6、 Resin artwork surface color guarantee does not fade. 树脂艺术品表面颜色保证不褪色。

7、 Seamless metal joints, bending polished smooth. 金属接缝处无缝隙, 折弯处打磨光滑。

8、 摆件雕塑必须牢固、稳定、安全、与灯光很好结合。

9、 石材基座必须做好加固, 以防碰撞引起倒掉。

10、 落地安放艺术品要稳、安全。

平面图

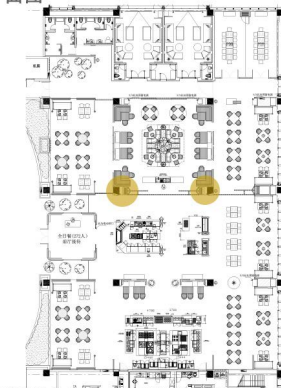

图片仅供参考, 以最终效果为准。

注: 1、实际艺术品以中标单位现场核实具体尺寸数量再深化为准;
2、此点位需灯光照亮, 需灯光顾问配合处理。

Project 项目名称: 杭州天目山格芮精选希尔顿酒店 Serial number 项目编号: 1F-ADD-05

Material 材质: 陶瓷+玻璃+真书书籍

Process description 工艺说明:

Area 区域: 一层全日餐厅

Number 数量: 2组

Size 尺寸: 详见清单



Furnishing articles and sculpture process requirements

摆件及雕塑工艺要求

1、 Art as the main theme, style, the main form of expression, need to have a strong visual impact

艺术品作为主题思想、风格的主要表现形式, 需要具有很强的视觉冲击力。

2、 First, the designer confirmed the design, selected processing materials.

首先草图, 效果图由设计师确认, 选定加工材料。

3、 According to the site, to determine the size of the sculpture. 根据现场, 图纸确定雕塑、摆件大小尺寸。

4、 Make mud draft, foam model, confirm the overall effect. 制作泥稿、泡沫模型, 确认整体效果。

5、 Indoor metal art material thickness shall not be less than 1.5 mm, resin thickness shall not be less than 3mm.

金属艺术品材料壁厚室内不得低于1.5mm,树脂壁厚不得低于3mm。

6、 Resin artwork surface color guarantee does not fade. 树脂艺术品表面颜色保证不褪色。

7、 Seamless metal joints, bending polished smooth. 金属接缝处无缝隙, 折弯处打磨光滑。

8、 摆件雕塑必须牢固、稳定、安全、与灯光很好结合。

9、 石材基座必须做好加固, 以防碰撞引起倒掉。

10、 落地安放艺术品要稳、安全。

平面图

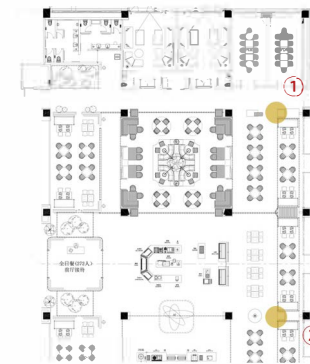

图片仅供参考, 以最终效果为准。

注: 1、实际艺术品以中标单位现场核实具体尺寸数量再深化为准;
2、此点位需灯光照亮, 需灯光顾问配合处理。

Furnishing articles and sculpture process requirements

摆件及雕塑工艺要求

- 1、 Art as the main theme, style, the main form of expression, need to have a strong visual impact
艺术品作为主题思想、风格的主要表现形式, 需要具有很强的视觉冲击力。
- 2、 First, the designer confirmed the design, selected processing materials.
首先草图, 效果图由设计师确认, 选定加工材料。
- 3、 According to the site, to determine the size of the sculpture.
根据现场, 图纸确定雕塑、摆件大小尺寸。
- 4、 Make mud draft, foam model, confirm the overall effect.
制作泥稿、泡沫模型, 确认整体效果。
- 5、 Indoor metal art material thickness shall not be less than 1.5 mm, resin thickness shall not be less than 3mm.
金属艺术品材料壁厚室内不得低于1.5mm, 树脂壁厚不得低于3mm。
- 6、 Resin artwork surface color guarantee does not fade.
树脂艺术品表面颜色保证不褪色。
- 7、 Seamless metal joints, bending polished smooth.
金属接缝处无缝隙, 折弯处打磨光滑。
- 8、 摆件雕塑必须牢固、稳定、安全、与灯光很好结合。
- 9、 石材基座必须做好加重加固, 以防碰撞引起倒掉。
- 10、 落地安放艺术品要稳、安全。

平面图

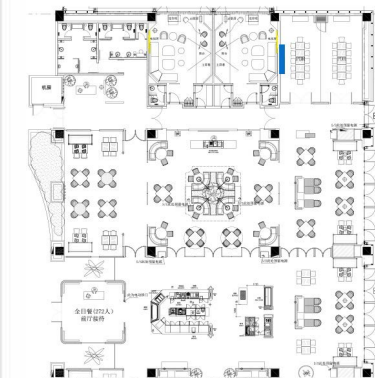

图片仅供参考, 以最终效果为准。

材质细节: 多层纸浆



灵感来源: 待放花苞

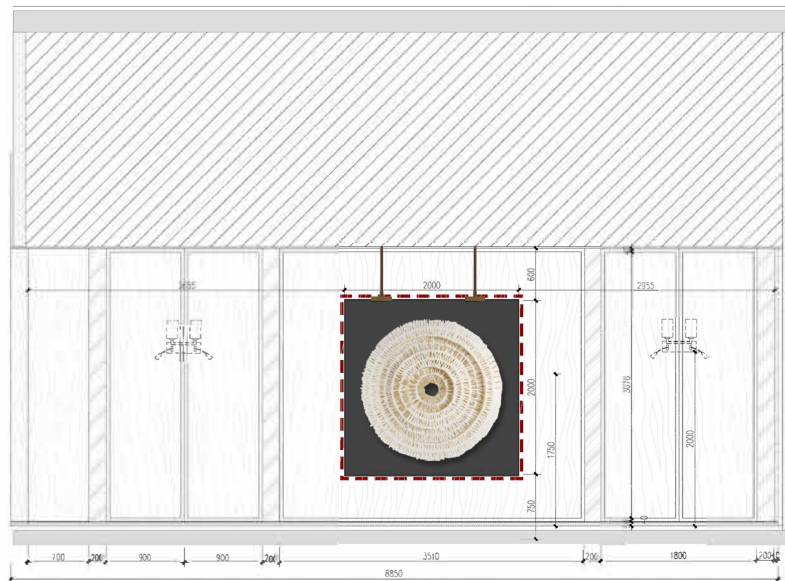

注: 1、实际艺术品以中标单位现场核实具体尺寸数量再深化为准;
2、此点位需灯光照亮, 需灯光顾问配合处理。
3、红框位置为加固区域, 需墙面加固厚度18mm木工板。



金属挂件

黑色木质画框

灰色底板

多层纸浆

2000

600

2000

Project 项目名称: 杭州天目山格芮精选希尔顿酒店 Serial number 项目编号: 1F-ADD-07

Material 材质: 多层纸浆+灰色底板+黑色木框+金属挂件

Process description 工艺说明:

Area 区域: 一层全日餐厅

Number 数量: 1件

Size 尺寸: W2000*D50*H2600

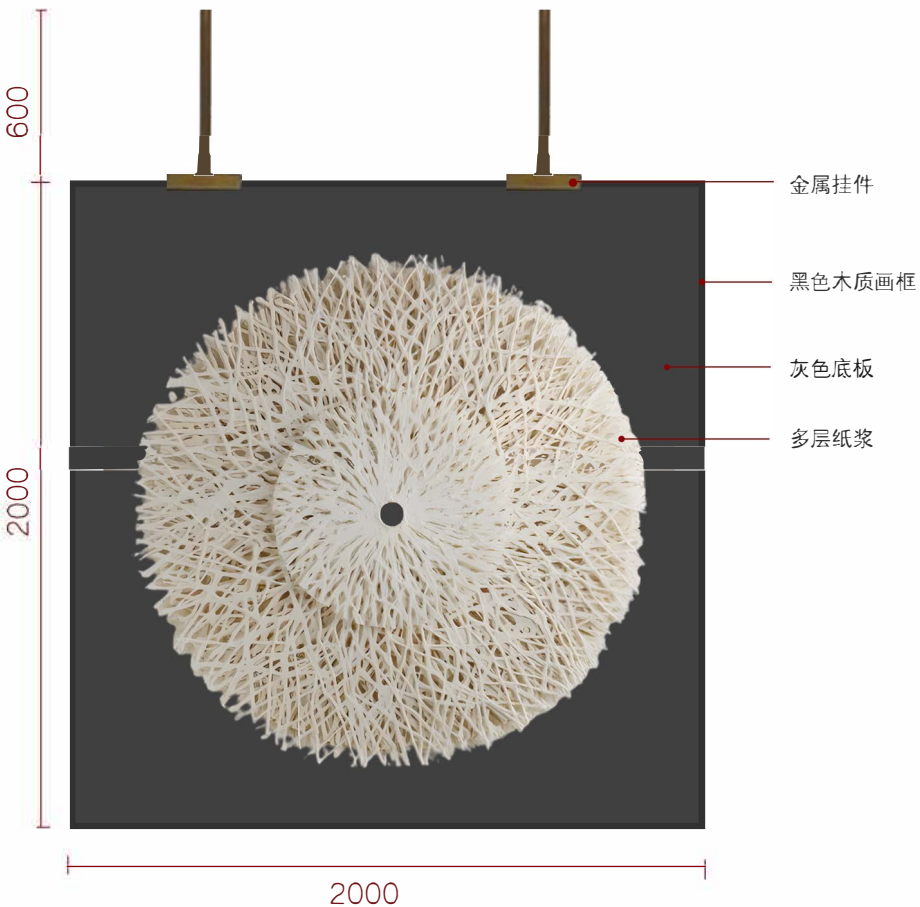

材质细节: 多层纸浆



灵感来源: 待放花苞

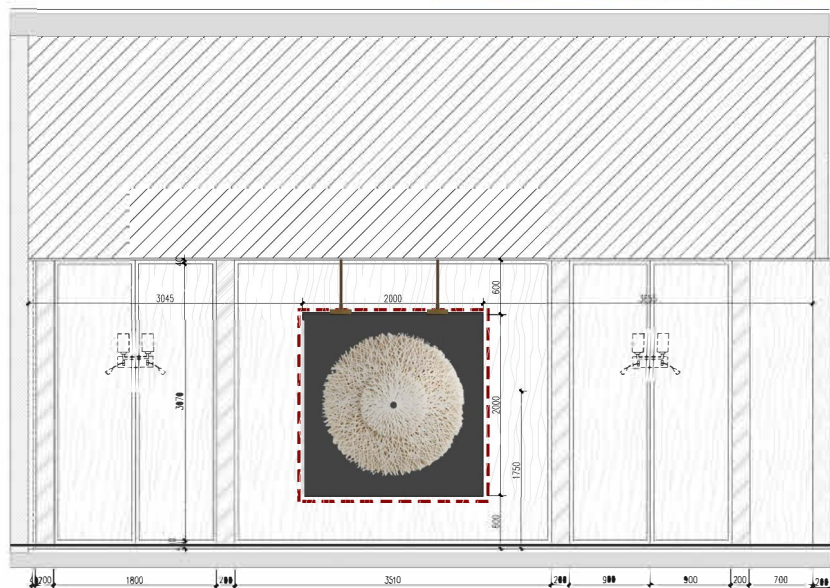

注: 1、实际艺术品以中标单位现场核实具体尺寸数量再深化为准;
 2、此点位需灯光照亮, 需灯光顾问配合处理。
 3、红框位置为加固区域, 需墙面加固厚度18mm木工板。

Furnishing articles and sculpture process requirements

摆件及雕塑工艺要求

1、 Art as the main theme, style, the main form of expression, need to have a strong visual impact

艺术品作为主题思想、风格的主要表现形式, 需要具有很强的视觉冲击力。

2、 First, the designer confirmed the design, selected processing materials.

首先草图, 效果图由设计师确认, 选定加工材料。

3、 According to the site, to determine the size of the sculpture. 根据现场, 图纸确定雕塑、摆件大小尺寸。

4、 Make mud draft, foam model, confirm the overall effect. 制作泥稿、泡沫模型, 确认整体效果。

5、 Indoor metal art material thickness shall not be less than 1.5 mm, resin thickness shall not be less than 3mm.

金属艺术品材料壁厚室内不得低于1.5mm, 树脂壁厚不得低于3mm。

6、 Resin artwork surface color guarantee does not fade. 树脂艺术品表面颜色保证不褪色。

7、 Seamless metal joints, bending polished smooth. 金属接缝处无缝隙, 折弯处打磨光滑。

8、 摆件雕塑必须牢靠、稳定、安全、与灯光很好结合。

9、 石材基座必须做好加固加固, 以防碰撞引起倒掉。

10、 落地安放艺术品要稳、安全。

平面图

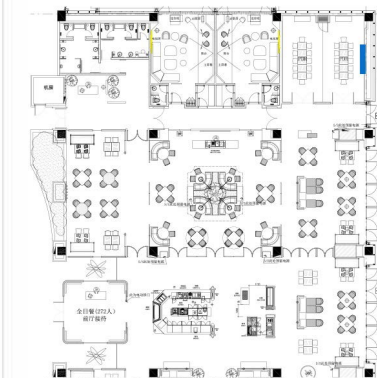

图片仅供参考, 以最终效果为准。

Project 项目名称: 杭州天目山格芮精选希尔顿酒店 Serial number 项目编号: 1F-ADD-08

Material 材质: 喷绘画面+麻布底+木质画框

Process description 工艺说明:

区域: 一层全日餐厅

Number

数量: 2件

Size

尺寸: W700*D25*H700, W700*D25*H700



灵感来源: 花朵绽放

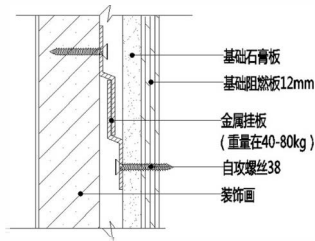

白色木质画框

喷绘画面

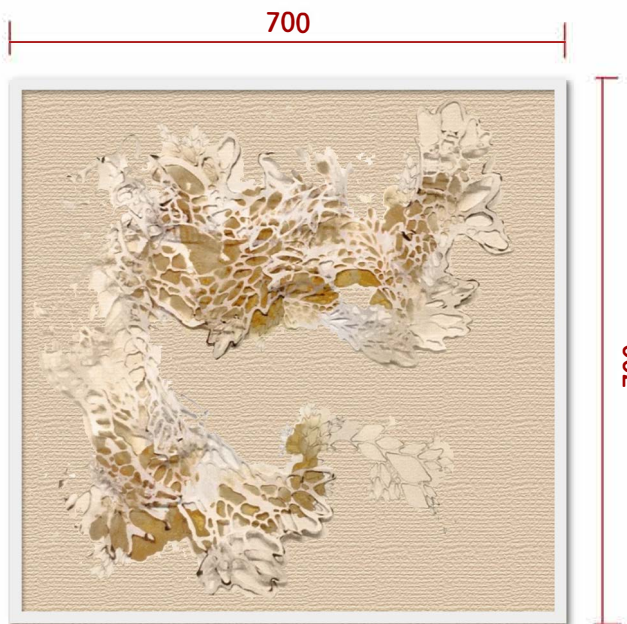
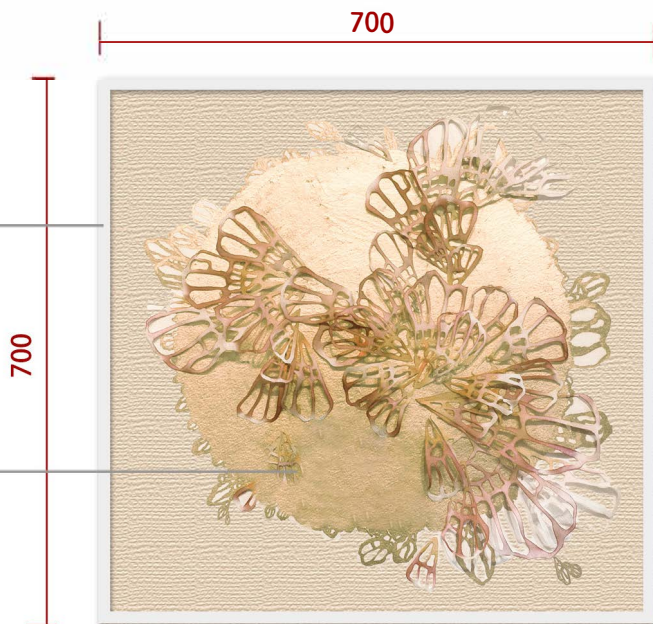

以绽放为主题, 巧妙地捕捉了花苞绽放前的那一刹那, 将这份静谧和期待凝固成了永恒。
它的形态优雅, 线条流畅, 每一个细节都充满了生命力和诗意, 让人沉醉其中, 仿佛置身于一个充满奇迹和美丽的花园中。
TAKING BLOOM AS THE THEME, IT CLEVERLY CAPTURES THE MOMENT BEFORE THE BUDS BLOOM, BOLIDIFYING THIS TRANQUILITY AND EXPECTATION INTO ETERNITY.
ITS SHAPE IS ELEGANT, ITS LINES ARE SMOOTH, AND EVERY DETAIL IS FULL OF VITALITY AND POETRY, MAKING PEOPLE IMMERSED IN IT, AS IF THEY ARE IN A GARDEN FULL OF MIRACLES AND BEAUTY.

Furnishing articles and sculpture process requirements

摆件及雕塑工艺要求

- 1、 Art as the main theme, style, the main form of expression, need to have a strong visual impact
艺术品作为主题思想、风格的主要表现形式, 需要具有很强的视觉冲击力。
- 2、 First, the designer confirmed the design, selected processing materials.
首先草图, 效果图由设计师确认, 选定加工材料。
- 3、 According to the site, to determine the size of the sculpture.
根据现场, 图纸确定雕塑、摆件大小尺寸。
- 4、 Make mud draft, foam model, confirm the overall effect.
制作泥稿、泡沫模型, 确认整体效果。
- 5、 Indoor metal art material thickness shall not be less than 1.5 mm, resin thickness shall not be less than 3mm.
金属艺术品材料厚度室内不得低于1.5mm树脂厚度不得低于3mm。
Resin artwork surface color guarantee does not fade.
树脂艺术品表面颜色保证不褪色。
- 7、 Seamless metal joints, bending polished smooth.
金属接缝处无缝隙, 折弯处打磨光滑。
- 8、 摆件雕塑必须牢固、稳定、安全、与灯光很好结合。
- 9、 石材基座必须做好加重加固, 以防碰撞引起倒塌。
- 10、 落地安放艺术品要稳、安全。

平面图

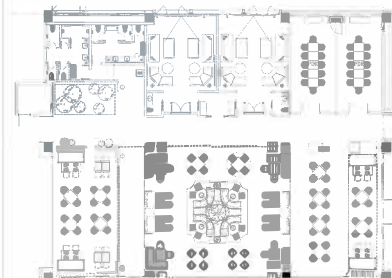

图片仅供参考, 以最终效果为准。

注: 1、实际艺术品以中标单位现场核实具体尺寸数量再深化为准;
2、此点位需灯光照亮, 需灯光顾问配合处理。

Project 项目名称: 杭州天目山格芮精选希尔顿酒店 Serial number 项目编号: 1F-ADD-08

Material 材质: 喷绘画面+表面肌理纹路+木质画框

Process description 工艺说明:

Area 区域: 一层全日餐厅

Number 数量: 2件

Size 尺寸: W700*D30*H700,W700*D30*H700

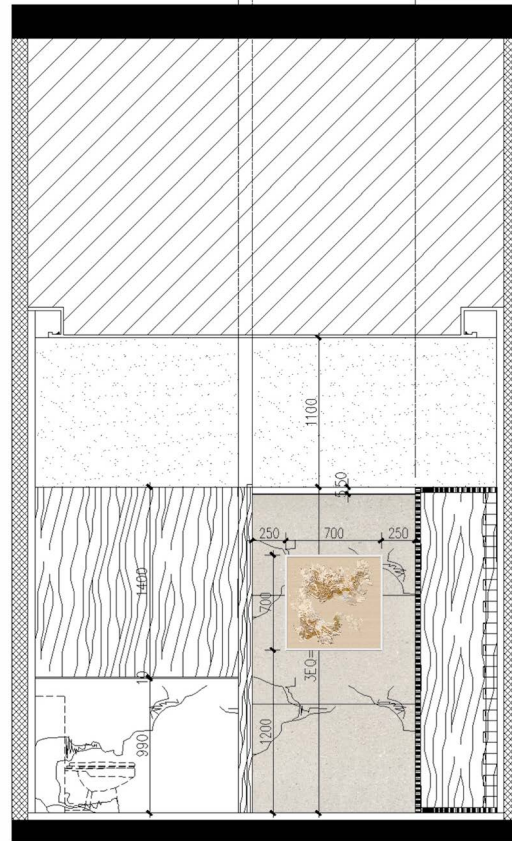
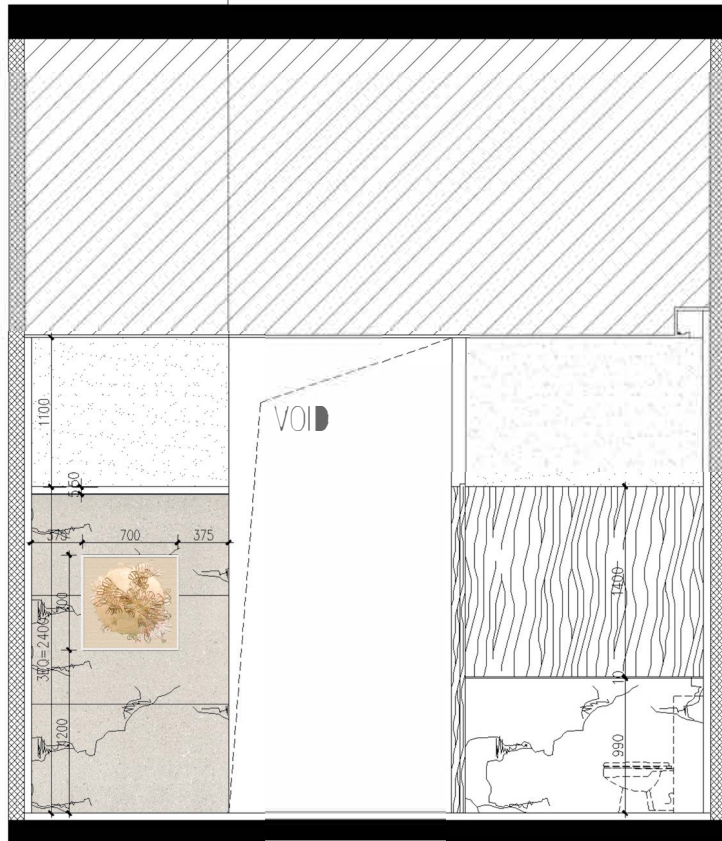

材质参考: 喷绘画面+表面肌理纹路

Furnishing articles and sculpture process requirements

摆件及雕塑工艺要求

- 1、Art as the main theme, style, the main form of expression, need to have a strong visual impact
艺术品作为主题思想、风格的主要表现形式, 需要具有很强的视觉冲击力。
- 2、First, the designer confirmed the design, selected processing materials.
首先草图, 效果图由设计师确认, 选定加工材料。
- 3、According to the site, to determine the size of the sculpture.
根据现场, 图纸确定雕塑、摆件大小尺寸。
- 4、Make mud draft, foam model, confirm the overall effect.
制作泥稿、泡沫模型, 确认整体效果。
- 5、Indoor metal art material thickness shall not be less than 1.5 mm, resin thickness shall not be less than 3mm.
金属艺术品材料厚度室内不得低于1.5mm, 树脂厚度不得低于3mm。
- 6、Resin artwork surface color guarantee does not fade.
树脂艺术品表面颜色保证不褪色。
- 7、Seamless metal joints, bending polished smooth.
金属接缝处无缝隙, 折弯处打磨光滑。
- 8、摆件雕塑必须牢固、稳定、安全、与灯光很好结合。
- 9、石材基座必须做好加重加固, 以防碰撞引起倒掉。
- 10、落地安放艺术品要稳、安全。

平面图

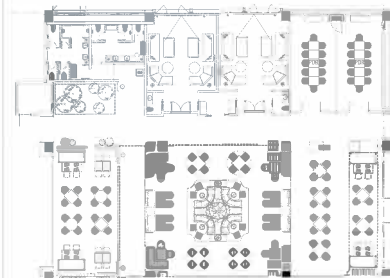

图片仅供参考, 以最终效果为准。

注: 1、实际艺术品以中标单位现场核实具体尺寸数量再深化为准;
2、此点位需灯光照亮, 需灯光顾问配合处理。

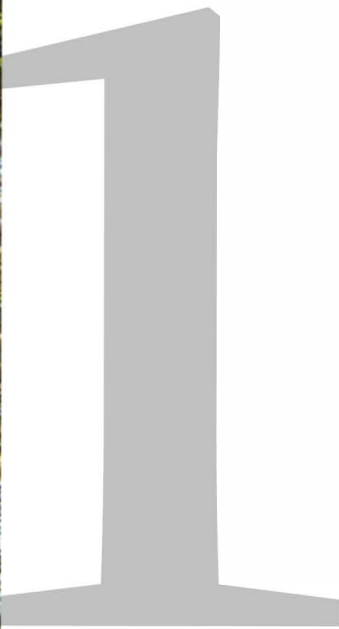

一层康体&泳池

FIRST FLOOR FITNESS & SWIMMING POOL

[盘根错节]
involved

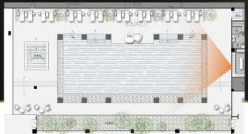

一层泳池效果图

FIRST FLOOR SWIMMING POOL RENDERINGS

OUTDOOR SWIMMING POOL

一层泳池



树根是生命的象征，它们蔓延到土壤中，为大树提供源源不断的能量。
通过树根的蜿蜒曲折造型，雕塑以弯曲的圆形，表面盘根的纹理，表现出向上生命力的艺术装置。

Tree roots are a symbol of life. They spread into the soil and provide a steady stream of energy for the tree.
Through the meandering shape of the tree roots, the sculpture uses a curved circle and a tangled texture on the surface to express the upward vitality of the art installation.

区域: 一层泳池

Number

数量: 2件

Size

尺寸: W1500*D1000*H1500, W1000*D600*H1000



材质: 仿汉玉, 半通透光



灵感来源: 树根弯曲



树根是生命的象征, 它们蔓延到土壤中, 为大树提供源源不断的能量。通过树根的蜿蜒曲折造型, 雕塑以弯曲的圆形, 表面盘根的纹理, 表现出向上生命力的艺术装置。

TREE ROOTS ARE A SYMBOL OF LIFE. THEY SPREAD INTO THE SOIL AND PROVIDE A STEADY STREAM OF ENERGY FOR THE TREE. THROUGH THE MEANDERING SHAPE OF THE TREE ROOTS, THE SCULPTURE USES A CURVED CIRCLE AND AN ENTANGLED TEXTURE ON THE SURFACE TO EXPRESS THE UPWARD VITALITY OF THE ART INSTALLATION.

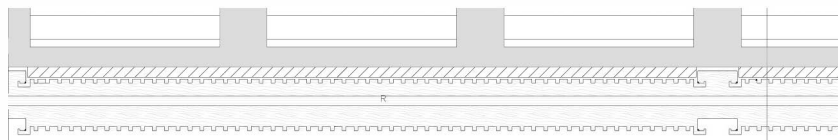
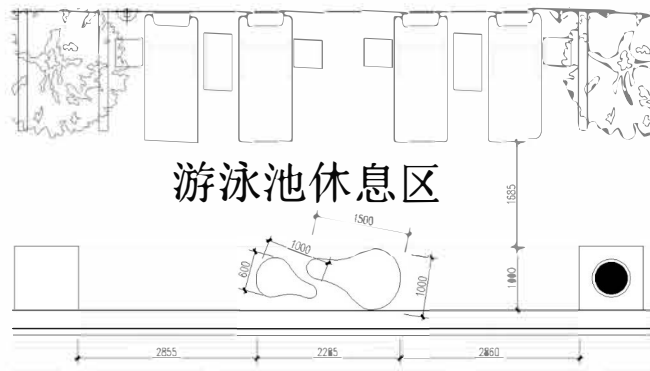

灯光雕塑底部向上打光照亮

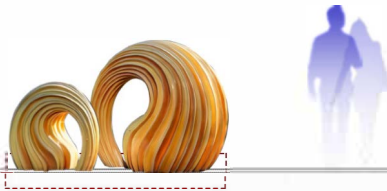

注:

- 1、实际艺术品以中标单位现场核实具体尺寸数量再深化为准;
- 2、此点位需灯光照亮, 需灯光顾问配合处理。

Furnishing articles and sculpture process requirements

摆件及雕塑工艺要求

- 1、Art as the main theme, style, the main form of expression, need to have a strong visual impact
艺术品作为主题思想、风格的主要表现形式, 需要具有很强的视觉冲击力。
- 2、First, the designer confirmed the design, selected processing materials.
首先草图, 效果图由设计师确认, 选定加工材料。
- 3、According to the site, to determine the size of the sculpture.
根据现场, 图纸确定雕塑、摆件大小尺寸。
- 4、Make mud draft, foam model, confirm the overall effect.
制作泥稿、泡沫模型, 确认整体效果。
- 5、Indoor metal art material thickness shall not be less than 1.5 mm, resin thickness shall not be less than 3mm.
金属艺术品材料厚度室内不得低于1.5mm, 树脂厚度不得低于3mm。
- 6、Resin artwork surface color guarantee does not fade.
树脂艺术品表面颜色保证不褪色。
- 7、Seamless metal joints, bending polished smooth.
金属接缝处无缝隙, 折弯处打磨光滑。
- 8、摆件雕塑必须牢固、稳定、安全、与灯光很好结合。
- 9、石材基座必须做好加重加固, 以防碰撞引起倒掉。
- 10、落地安放艺术品要稳、安全。

平面图

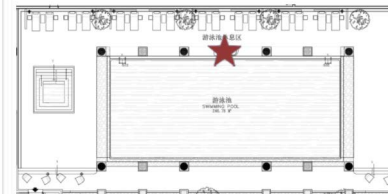

图片仅供参考, 以最终效果为准。



一层康体效果图

FIRST FLOOR WELLNESS RENDERINGS

FOREST SECRET REALM

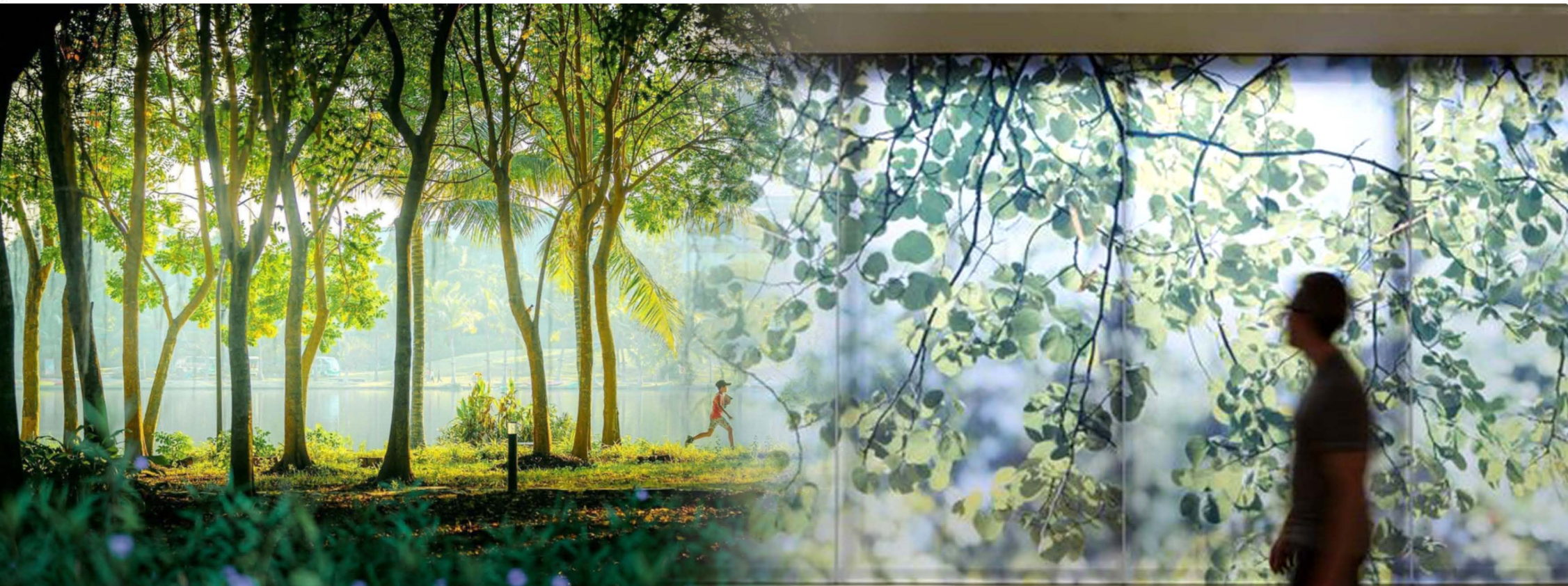

围绕着森林秘境，仿佛置身于一个充满生机的世界，小手轻抚着树叶，感受着那细腻的纹理和生命的脉动，心灵也在这绿意盎然中得到了净化与升华。树叶在阳光的照耀下闪闪发光，带来了无尽的欢乐与惊喜。追逐着飘落的树叶，欢笑声在空气中回荡，如同美妙的音乐，为这个世界增添了一抹动人的色彩。

SURROUNDING THE SECRET REALM OF THE FOREST, YOU FEEL LIKE YOU ARE IN A WORLD FULL OF VITALITY. YOU CARESS THE LEAVES WITH YOUR LITTLE HANDS, FEELING THE DELICATE TEXTURE AND THE PULSE OF LIFE. YOUR SOUL IS PURIFIED AND SUBLIMATED IN THIS LUSH GREENERY. THE LEAVES SPARKLE IN THE SUNLIGHT, BRINGING ENDLESS JOY AND SURPRISE. CHASING THE FALLING LEAVES, LAUGHTER ECHOED IN THE AIR, LIKE WONDERFUL MUSIC, ADDING A TOUCH OF MOVING COLOR TO THE WORLD.

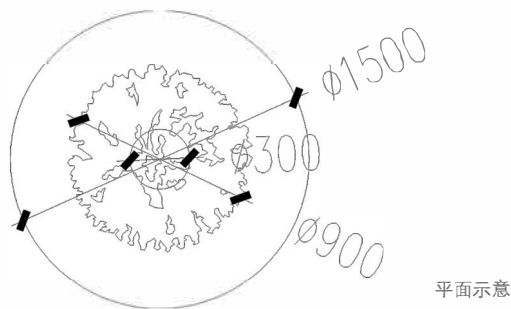

精致的花艺与SPA区的氛围相得益彰, 让人在放松身心的同时, 也能欣赏到自然之美, 感受到生活的诗意与浪漫。

THE EXQUISITE FLORAL ARRANGEMENTS COMPLEMENT THE ATMOSPHERE OF THE SPA AREA, ALLOWING PEOPLE TO RELAX THEIR BODY AND MIND WHILE ALSO APPRECIATING THE BEAUTY OF NATURE AND FEELING THE POETRY AND ROMANCE OF LIFE.

Furnishing articles and sculpture process requirements

摆件及雕塑工艺要求

1、Art as the main theme, style, the main form of expression, need to have a strong visual impact

艺术品作为主题思想、风格的主要表现形式, 需要具有很强的视觉冲击力。

2、First, the designer confirmed the design, selected processing materials.

首先草图, 效果图由设计师确认, 选定加工材料。

3、According to the site, to determine the size of the sculpture. 根据现场, 图纸确定雕塑、摆件大小尺寸。

4、Make mud draft, foam model, confirm the overall effect. 制作泥稿、泡沫模型, 确认整体效果。

5、Indoor metal art material thickness shall not be less than 1.5 mm, resin thickness shall not be less than 3mm.

金属艺术品材料厚度室内不得低于1.5mm,树脂厚度不得低于3mm。

6、Resin artwork surface color guarantee does not fade. 树脂艺术品表面颜色保证不褪色。

7、Seamless metal joints, bending polished smooth. 金属接缝处无缝隙, 折弯处打磨光滑。

8、摆件雕塑必须牢固、稳定、安全、与灯光很好结合。

9、石材基座必须做好加重加固, 以防碰撞引起倒掉。

10、落地安放艺术品要稳、安全。

平面图

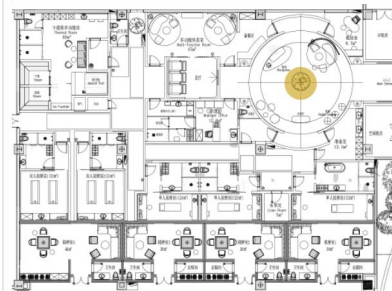

图片仅供参考, 以最终效果为准。

注: 1、实际艺术品以中标单位现场核实具体尺寸数量再深化为准;
2、此点位需灯光照亮, 需灯光顾问配合处理。

花瓶绿植:D1250*H1650,花瓶:D180*H650,风灯:D330*H520

在 SPA 区, 葱郁的树木宛如绿色的帷幕, 风灯点缀其间, 如点点繁星坠落, 营造出一片宁静而梦幻的氛围。

IN THE SPA AREA, LUSH TREES ARE LIKE A GREEN CURTAIN, AND WIND LANTERNS ARE DOTTED AMONG THEM, LIKE STARS FALLING, CREATING A PEACEFUL AND DREAMY ATMOSPHERE.



Furnishing articles and sculpture process requirements

摆件及雕塑工艺要求

- 1、Art as the main theme, style, the main form of expression, need to have a strong visual impact
艺术品作为主题思想、风格的主要表现形式, 需要具有很强的视觉冲击力。
- 2、First, the designer confirmed the design, selected processing materials.
首先草图, 效果图由设计师确认, 选定加工材料。
- 3、According to the site, to determine the size of the sculpture. 根据现场, 图纸确定雕塑、摆件大小尺寸。
- 4、Make mud draft, foam model, confirm the overall effect. 制作泥稿、泡沫模型, 确认整体效果。
- 5、Indoor metal art material thickness shall not be less than 1.5 mm, resin thickness shall not be less than 3mm.
金属艺术品材料厚度室内不得低于1.5mm,树脂厚度不得低于3mm。
- 6、Resin artwork surface color guarantee does not fade. 树脂艺术品表面颜色保证不褪色。
- 7、Seamless metal joints, bending polished smooth. 金属接缝处无缝隙, 折弯处打磨光滑。
- 8、摆件雕塑必须牢固、稳定、安全、与灯光很好结合。
- 9、石材基座必须做好加重加固, 以防碰撞引起倒掉。
- 10、落地安放艺术品要稳、安全。

平面图

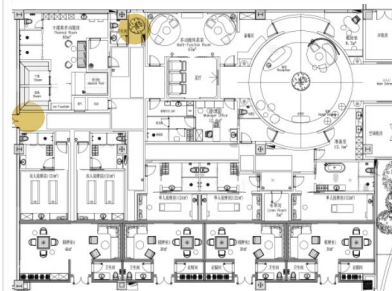

图片仅供参考, 以最终效果为准。

注: 1、实际艺术品以中标单位现场核实具体尺寸数量再深化为准;
2、此点位需灯光照亮, 需灯光顾问配合处理。



Project 项目名称: 杭州天目山格芮精选希尔顿酒店 Serial number 项目编号: 1F-WS-04

Material 材质: 仿真树叶+亚克力拼接金属+金属吊线+落地绿植永生苔藓 Process description 工艺说明:

域: 一层B区接待台

Number

数量: 1组

Size

尺寸: 吊饰: ϕ 1500*H2600, 落地绿植: W6000*D1200*H350

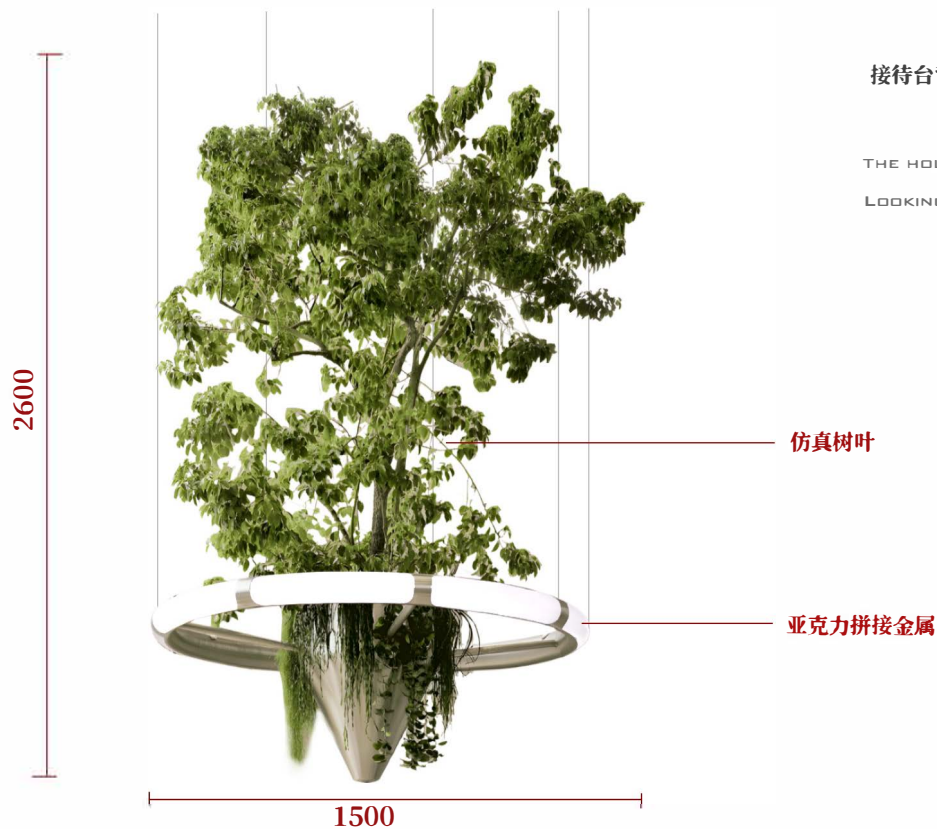

接待台背后的镂空位置, 犹如一扇神奇的窗口, 将森林树木的美巧妙地框取其中。
从四面望去, 都能捕捉到那独特的景致, 仿佛一幅灵动的画卷。

THE HOLLOW POSITION BEHIND THE RECEPTION DESK IS LIKE A MAGICAL WINDOW,
CLEVERLY FRAMING THE BEAUTY OF THE GINKGO TREE WITHIN IT.
LOOKING FROM ALL SIDES, ONE CAN CAPTURE THAT UNIQUE SCENERY, LIKE A DY-
NAMIC PAINTING.

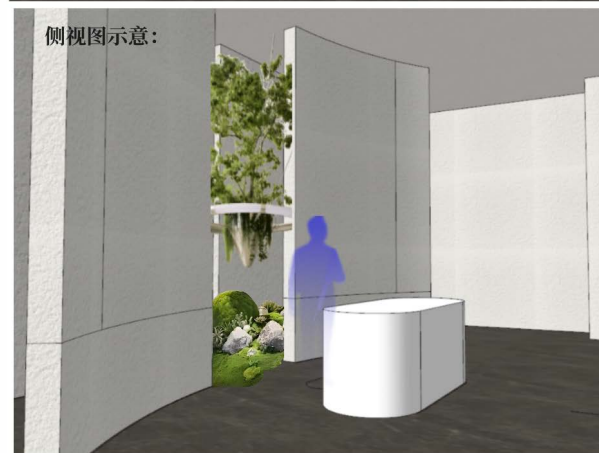

落地绿植范围尺寸: W6000*D1250*H350



注: 1、实际艺术品以中标单位现场核实具体尺寸数量再深化为准;
2、红框为加固区域,需天花加固双层18mm木工板。

Furnishing articles and sculpture process requirements

摆件及雕塑工艺要求

1、 Art as the main theme, style, the main form of expression, need to have a strong visual impact

艺术品作为主题思想、风格的主要表现形式, 需要具有很强的视觉冲击力。

2、 First, the designer confirmed the design, selected processing materials.

首先草图, 效果图由设计师确认, 选定加工材料。

3、 According to the site, to determine the size of the sculpture. 根据现场, 图纸确定雕塑、摆件大小尺寸。

4、 Make mud draft, foam model, confirm the overall effect. 制作泥稿、泡沫模型, 确认整体效果。

5、 Indoor metal art material thickness shall not be less than 1.5 mm, resin thickness shall not be less than 3mm.

金属艺术品材料壁厚室内不得低于1.5mm,树脂壁厚度不得低于3mm。

6、 Resin artwork surface color guarantee does not fade. 树脂艺术品表面颜色保证不褪色。

7、 Seamless metal joints, bending polished smooth. 金属接缝处无缝隙, 折弯处打磨光滑。

8、 摆件雕塑必须牢固、稳定、安全、与灯光很好结合。

9、 石材基座必须做好加重加固, 以防碰撞引起倒掉。

10、落地安放艺术品要稳、安全。

平面图



图片仅供参考, 以最终效果为准。

Project 项目名称: 杭州天目山格芮精选希尔顿酒店 Serial number 项目编号: 1F-WS-04

Material 材质: 仿真树叶+亚克力拼接金属+金属吊线+落地绿植永生苔藓

Process description 工艺说明:

域: 一层B区接待台

Number

数量: 1组

Size

尺寸: 吊饰: $\phi 1500 \times H2600$, 落地绿植: $W6000 \times D1200 \times H350$

平面示意:

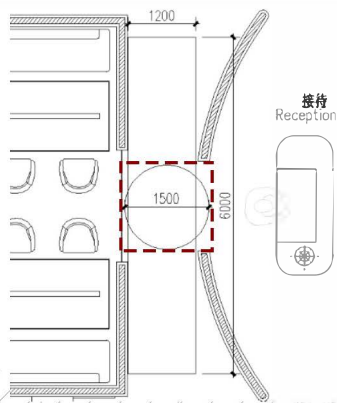

接待
Reception



注: 1、实际艺术品以中标单位现场核实具体尺寸数量再深化为准;
2、红框为加固区域,需天花加固双层18mm木工板。

Furnishing articles and sculpture process requirements

摆件及雕塑工艺要求

1、 Art as the main theme, style, the main form of expression, need to have a strong visual impact

艺术品作为主题思想、风格的主要表现形式,需要具有很强的视觉冲击力。

2、 First, the designer confirmed the design, selected processing materials.

首先草图,效果图由设计师确认,选定加工材料。

3、 According to the site, to determine the size of the sculpture. 根据现场,图纸确定雕塑、摆件大小尺寸。

4、 Make mud draft, foam model, confirm the overall effect. 制作泥稿、泡沫模型,确认整体效果。

5、 Indoor metal art material thickness shall not be less than 1.5 mm, resin thickness shall not be less than 3mm.

金属艺术品材料壁厚室内不得低于1.5mm,树脂壁厚不得低于3mm。

6、 Resin artwork surface color guarantee does not fade. 树脂艺术品表面颜色保证不褪色。

7、 Seamless metal joints, bending polished smooth. 金属接缝处无缝隙,折弯处打磨光滑。

8、 摆件雕塑必须牢固、稳定、安全、与灯光很好结合。

9、 石材基座必须做好加重加固,以防碰撞引起倒掉。

10、 落地安放艺术品要稳、安全。

平面图

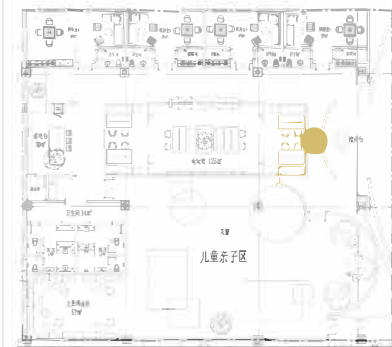

图片仅供参考,以最终效果为准。

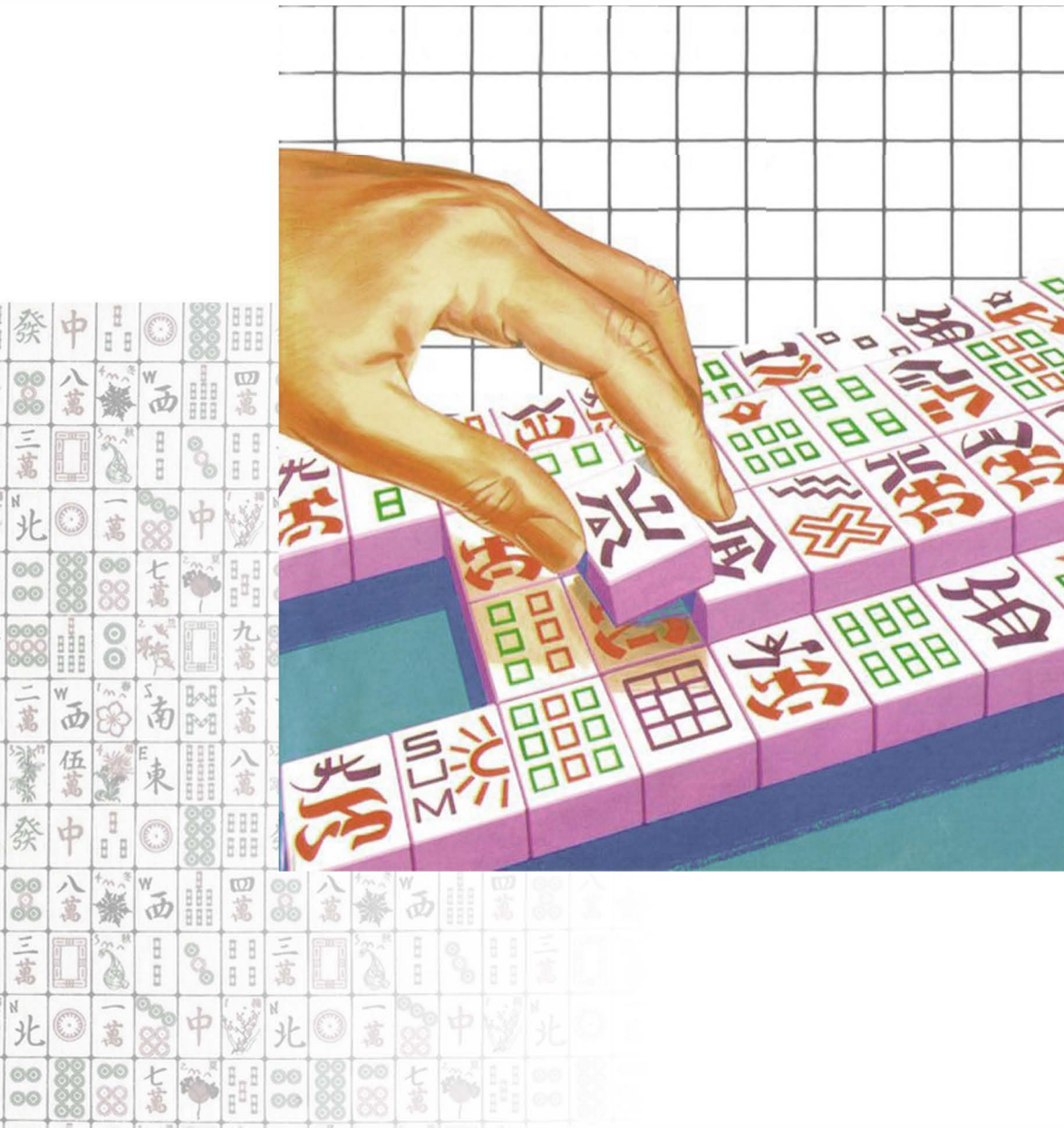

借鉴了未来抽象化的设计元素，让画面充满了前卫与新奇。那些流动的线条恰似自由的精灵，赋予了整个空间一种无拘无束的自由感，使人们仿佛不再局限于紧张的牌局之中，而是能超脱其外，沉浸在这独特的艺术氛围里。

DRAWING ON THE ABSTRACT DESIGN ELEMENTS OF THE FUTURE, THE PICTURE IS FULL OF AVANT-GARDE AND NOVELTY. THE FLOWING LINES ARE LIKE FREE SPIRITS, GIVING THE ENTIRE SPACE A SENSE OF UNFETTERED FREEDOM, MAKING PEOPLE FEEL AS IF THEY ARE NO LONGER CONFINED TO THE TENSE GAME OF CARDS, BUT CAN TRANSCEND IT AND IMMERSE THEMSELVES IN THIS UNIQUE ARTISTIC ATMOSPHERE.



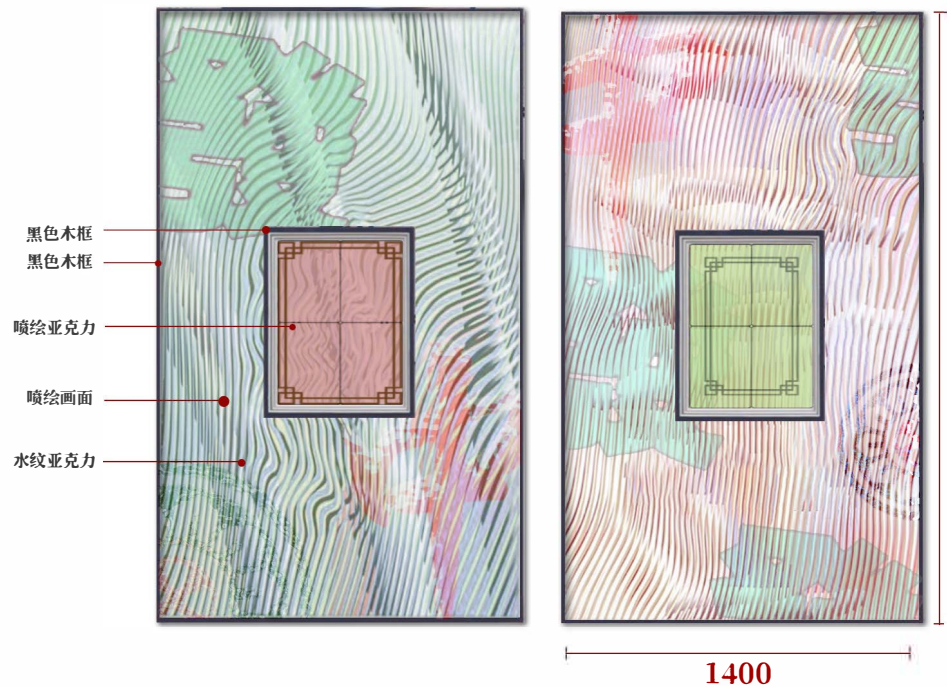

①

②

麻将的元素被巧妙融入。丰富且灵动的线条，借鉴了未来抽象化的设计元素，让画面充满了前卫与新奇。那些流动的线条赋予了整个空间一种无拘无束的自由感，沉浸在这独特的艺术氛围里。它们交织、跃动，勾勒出一个充满魅力与幻想的麻将世界，让人在欣赏之余，不禁对其中蕴含的智慧与灵动心生向往。

THE ELEMENTS OF MAHJONG ARE CLEVERLY INTEGRATED. THE RICH AND FLEXIBLE LINES, DRAWING ON THE ABSTRACT DESIGN ELEMENTS OF THE FUTURE, MAKE THE PICTURE FULL OF AVANT-GARDE AND NOVELTY. THOSE FLOWING LINES GIVE THE WHOLE SPACE A SENSE OF UNFETTERED FREEDOM, IMMERSING IN THIS UNIQUE ARTISTIC ATMOSPHERE. THEY INTERWEAVE AND JUMP, OUTLINING A MAHJONG WORLD FULL OF CHARM AND FANTASY, WHICH MAKES PEOPLE YEARN FOR THE WISDOM AND AGILITY CONTAINED IN IT WHILE APPRECIATING IT.

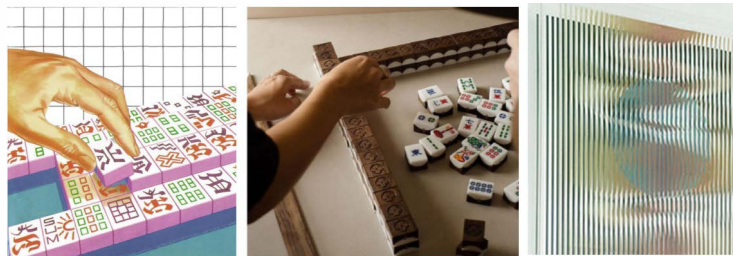

灵感来源: 朋克麻将元素

材质细节: 底部水纹亚克力

侧面示意:

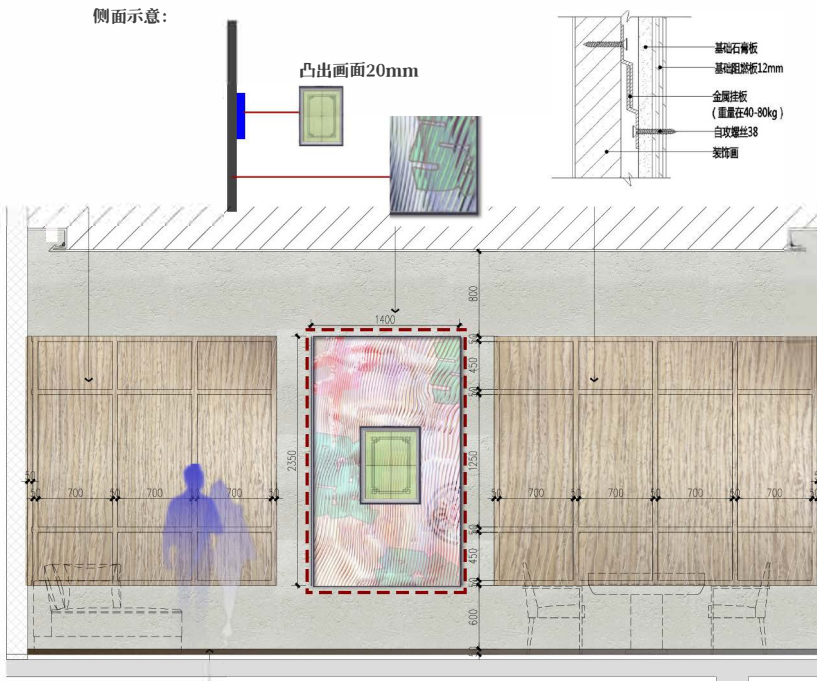

注:

- 1、实际艺术品以中标单位现场核实具体尺寸数量再深化为准;
- 2、此点位需灯光照亮,需灯光顾问配合处理;
- 3、红框为加固区域,需墙面加固厚度18mm木工板。

Furnishing articles and sculpture process requirements

摆件及雕塑工艺要求

1、 Art as the main theme, style, the main form of expression, need to have a strong visual impact

艺术品作为主题思想、风格的主要表现形式,需要具有很强的视觉冲击力。

2、 First, the designer confirmed the design, selected processing materials.

首先草图,效果图由设计师确认,选定加工材料。

3、 According to the site, to determine the size of the sculpture. 根据现场,图纸确定雕塑、摆件大小尺寸。

4、 Make mud draft, foam model, confirm the overall effect. 制作泥稿、泡沫模型,确认整体效果。

5、 Indoor metal art material thickness shall not be less than 1.5 mm, resin thickness shall not be less than 3mm.

金属艺术品材料厚度室内不得低于1.5mm,树脂厚度不得低于3mm。

6、 Resin artwork surface color guarantee does not fade. 树脂艺术品表面颜色保证不褪色。

7、 Seamless metal joints, bending polished smooth. 金属接缝处无缝隙,折弯处打磨光滑。

8、 摆件雕塑必须牢固、稳定、安全、与灯光很好结合。

9、 石材基座必须做好加重加固,以防碰撞引起倒掉。

10、 落地安放艺术品要稳、安全。

平面图

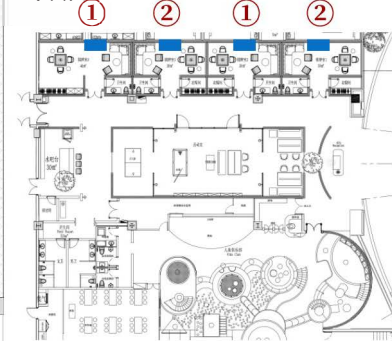

图片仅供参考,以最终效果为准。

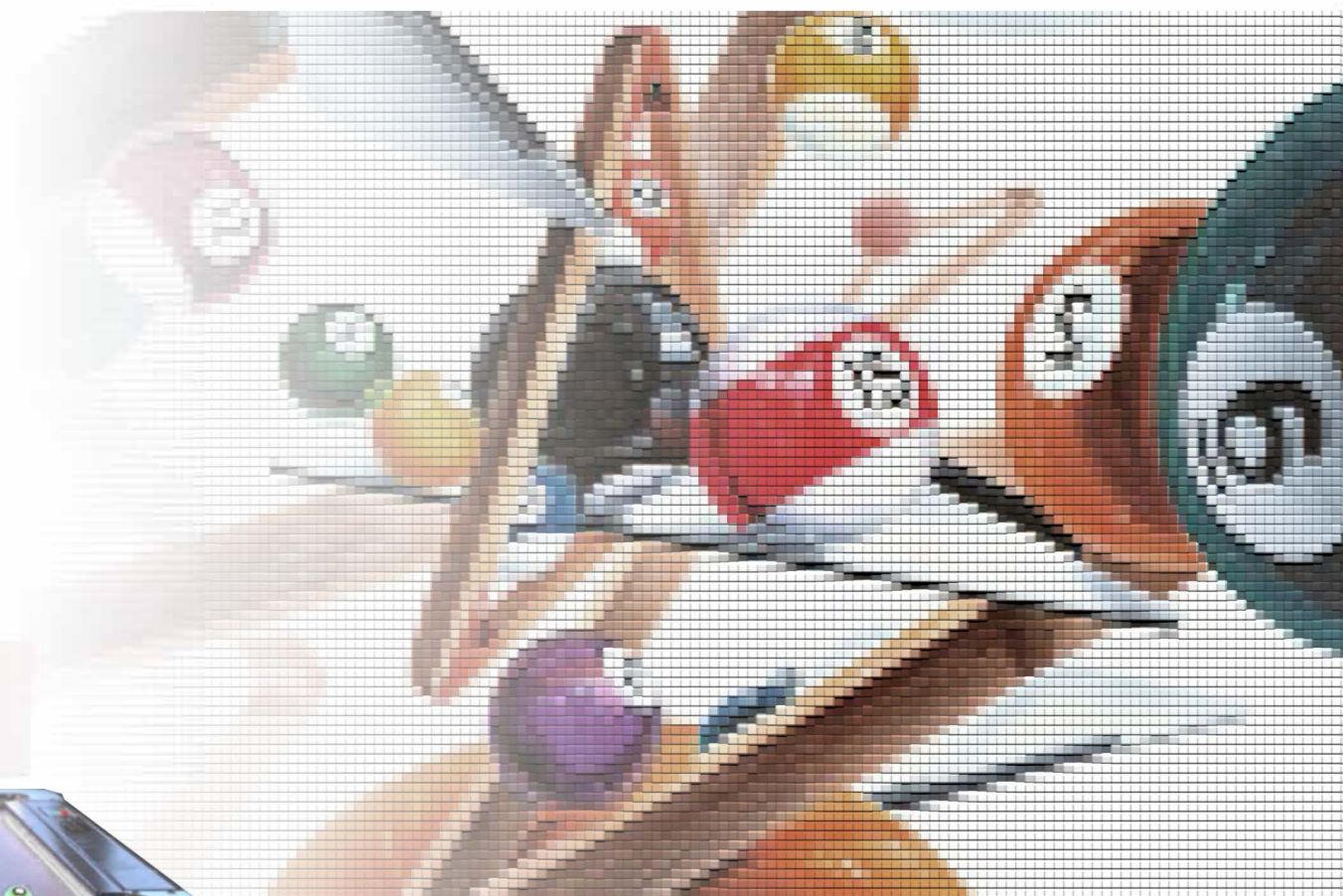
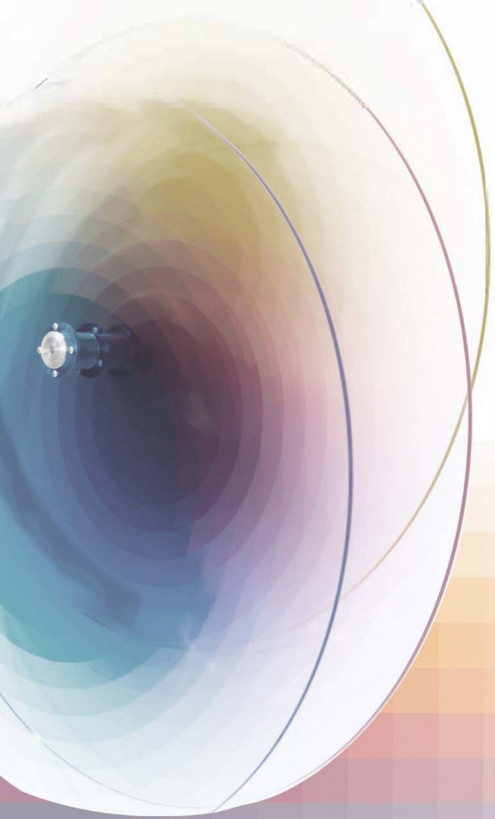

在电玩室中，艺术装置宛如一颗璀璨的明珠，散发着迷人的魅力。
它从台球和足球中汲取灵感，整体借鉴的电动马赛克元素，
如同为其披上了一层充满科技感的绚丽霓裳。
当灯光亮起，整个空间瞬间被点亮，
赛博朋克的动感效果如汹涌的浪潮喷薄而出。

IN THE VIDEO GAME ROOM, THE ART INSTALLATION IS LIKE A BRILLIANT PEARL,
EMITTING CHARMING CHARM.
IT DRAWS INSPIRATION FROM BILLIARDS AND FOOTBALL,
USING ELECTRIC MOSAIC ELEMENTS AS A WHOLE,
IT'S LIKE PUTTING ON A DAZZLING TECHNOLOGICAL GOWN FOR IT.
WHEN THE LIGHT COMES ON, THE ENTIRE SPACE IS INSTANTLY ILLUMINATED,
THE DYNAMIC EFFECT OF CYBERPUNK IS LIKE A SURGING WAVE SPRAYING OUT.

Project 项目名称: 杭州天目山格芮精选希尔顿酒店 Serial number 项目编号: 1F-WS-06

Material 材质: UV喷绘渐变颜色+亚克力+装置固定件

Process description 工艺说明:

Area 区域: 一层电玩室

Number 数量: 1件

Size 尺寸: W5000*D30*H3000

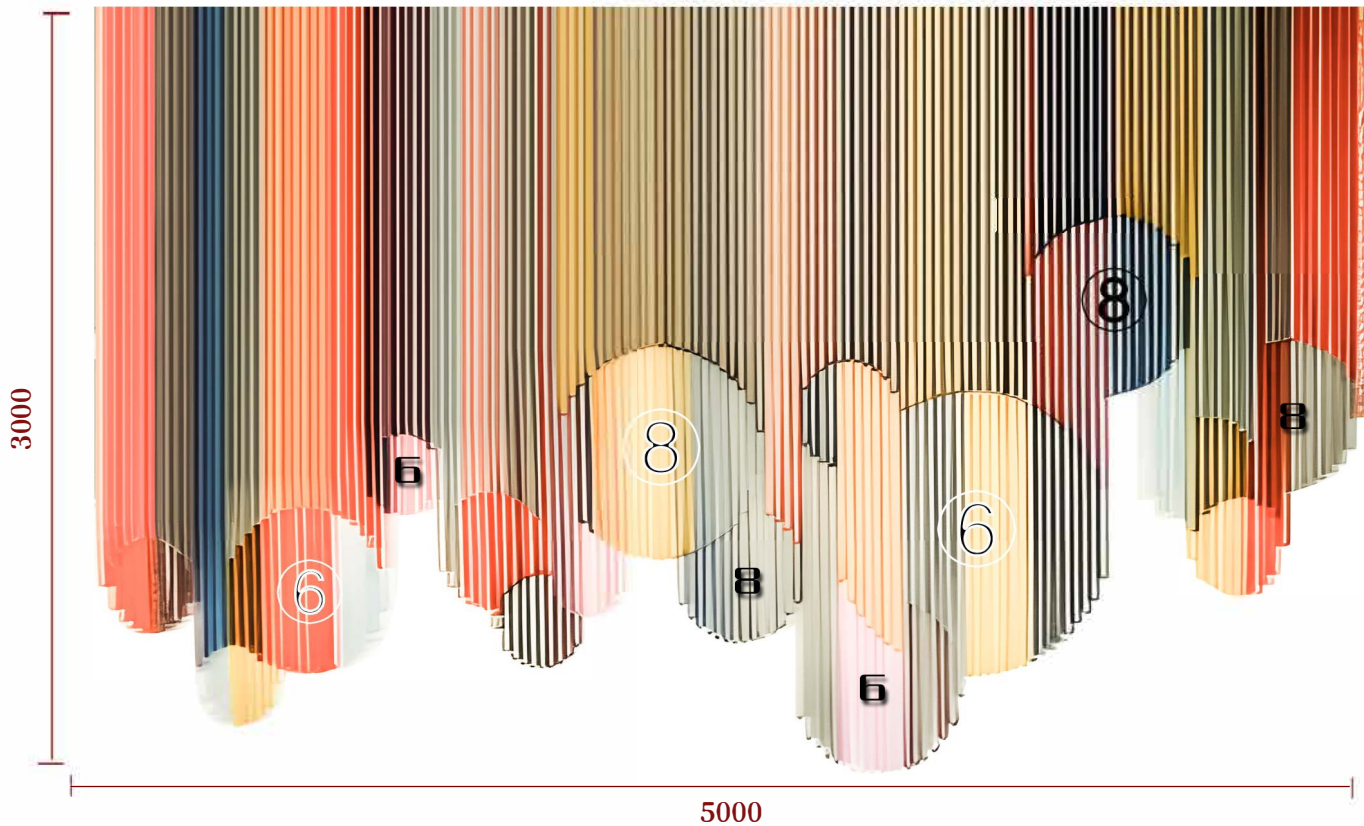

材质细节: 亚克力柱喷绘渐变颜色



灵感来源: 朋克台球元素

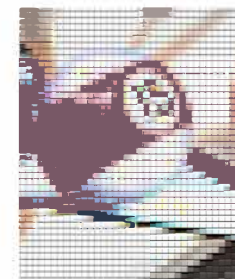

Furnishing articles and sculpture process requirements

摆件及雕塑工艺要求

1、 Art as the main theme, style, the main form of expression, need to have a strong visual impact

艺术品作为主题思想、风格的主要表现形式, 需要具有很强的视觉冲击力。

2、 First, the designer confirmed the design, selected processing materials.

首先草图, 效果图由设计师确认, 选定加工材料。

3、 According to the site, to determine the size of the sculpture. 根据现场, 图纸确定雕塑、摆件大小尺寸。

4、 Make mud draft, foam model, confirm the overall effect. 制作泥稿、泡沫模型, 确认整体效果。

5、 Indoor metal art material thickness shall not be less than 1.5 mm, resin thickness shall not be less than 3mm.

金属艺术品材料壁厚室内不得低于1.5mm, 树脂壁厚度不得低于3mm。

6、 Resin artwork surface color guarantee does not fade, 树脂艺术品表面颜色保证不褪色。

7、 Seamless metal joints, bending polished smooth. 金属接缝处无缝隙, 折弯处打磨光滑。

8、 摆件雕塑必须牢固、稳定、安全、与灯光很好结合。

9、 石材基座必须做好加重加固, 以防碰撞引起倒塌。

10、 落地安放艺术品要稳、安全。

平面图

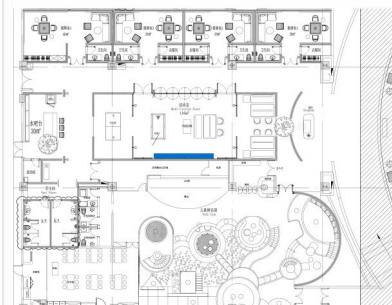

图片仅供参考, 以最终效果为准。

在电玩室中, 艺术装置宛如一颗璀璨的明珠, 散发着迷人的魅力。它从台球和足球中汲取灵感, 整体借鉴的电动马赛克元素, 如同为其披上了一层充满科技感的绚丽霓裳。当灯光亮起, 整个空间瞬间被点亮, 赛博朋克的动感效果如汹涌的浪潮喷薄而出。时而如柔和的月光, 洒在装置上, 营造出一种静谧而又充满张力的氛围, 仿佛是夜空中最宁静的角落。闪耀的灯光与装置相互呼应, 使得整个空间仿佛变成了一个未来的竞技场, 让人仿佛置身于梦幻的星际战场。

IN THE VIDEO GAME ROOM, THE ART INSTALLATION IS LIKE A BRILLIANT PEARL, EMITTING CHARMING CHARM. IT DRAWS INSPIRATION FROM BILLIARDS AND FOOTBALL, USING ELECTRIC MOSAIC ELEMENTS AS A WHOLE, IT'S LIKE PUTTING ON A DAZZLING TECHNOLOGICAL GOWN FOR IT. WHEN THE LIGHT COMES ON, THE ENTIRE SPACE IS INSTANTLY ILLUMINATED, THE DYNAMIC EFFECT OF CYBERPUNK IS LIKE A SURGING WAVE SPRAYING OUT. SOMETIMES, LIKE SOFT MOONLIGHT, IT FALLS ON THE DEVICE, CREATING A PEACEFUL AND TENSE ATMOSPHERE, AS IF IT WERE THE QUIETEST CORNER OF THE NIGHT SKY. THE DAZZLING LIGHTS AND INSTALLATIONS COMPLEMENT EACH OTHER, MAKING THE ENTIRE SPACE SEEM LIKE A FUTURE COMPETITIVE ARENA, MAKING PEOPLE FEEL LIKE THEY ARE IN A DREAMLIKE INTERSTELLAR BATTLEFIELD.

注:

- 1、实际艺术品以中标单位现场核实具体尺寸数量再深化为准;
- 2、此点位需灯光照亮, 需灯光顾问配合处理。

Project 项目名称: 杭州天目山格芮精选希尔顿酒店 Serial number 项目编号: 1F-WS-06

Material 材质: UV喷绘渐变颜色+亚克力+装置固定件

Process description 工艺说明:

Area 区域: 一层电玩室

Number 数量: 1件

Size 尺寸: W5000*D3000

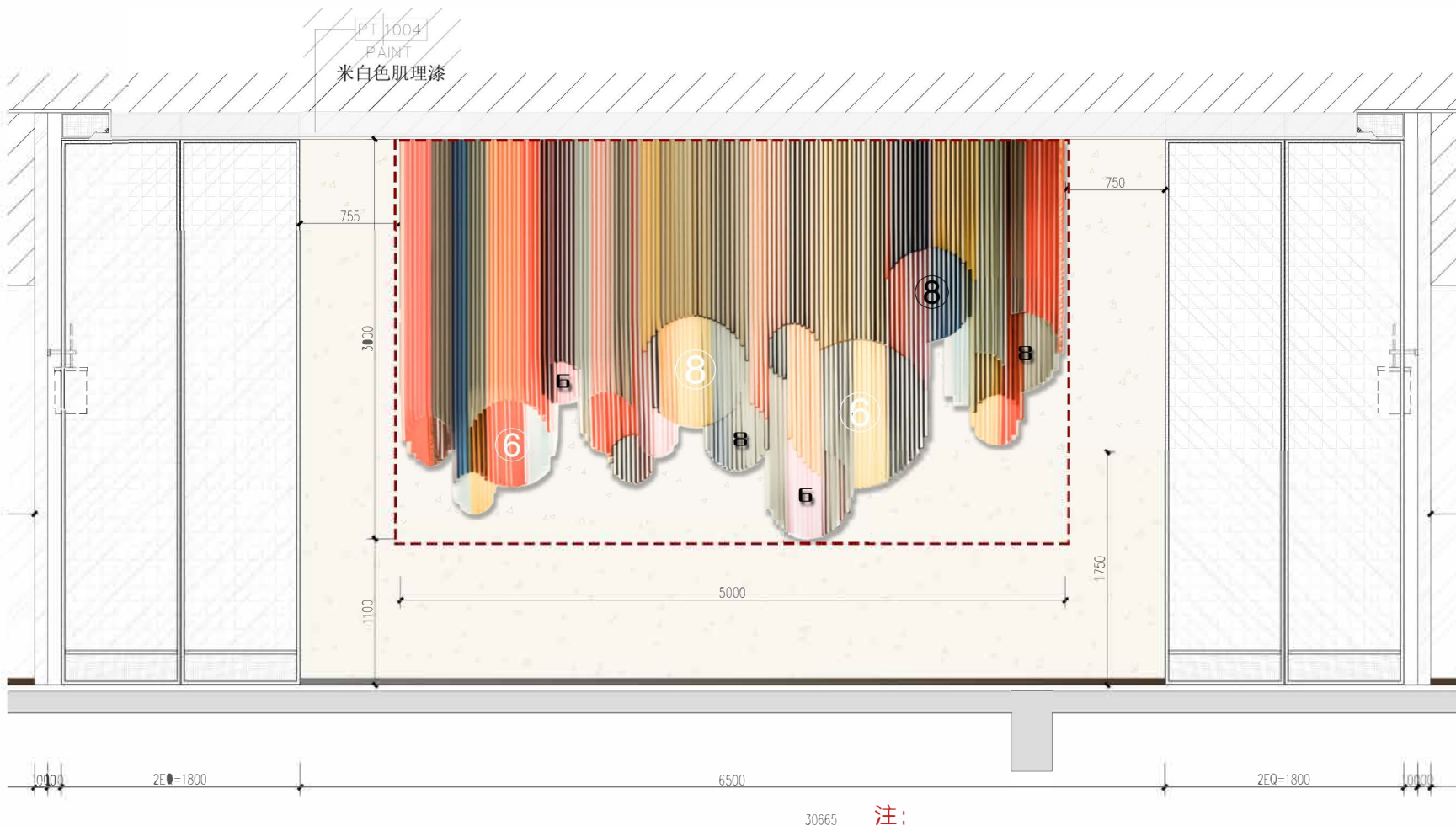

Furnishing articles and sculpture process requirements

摆件及雕塑工艺要求

- 1、 Art as the main theme, style, the main form of expression, need to have a strong visual impact
艺术品作为主题思想、风格的主要表现形式, 需要具有很强的视觉冲击力。
- 2、 First, the designer confirmed the design, selected processing materials.
首先草图, 效果图由设计师确认, 选定加工材料。
- 3、 According to the site, to determine the size of the sculpture. 根据现场, 图纸确定雕塑、摆件大小尺寸。
- 4、 Make mud draft, foam model, confirm the overall effect. 制作泥稿、泡沫模型, 确认整体效果。
- 5、 Indoor metal art material thickness shall not be less than 1.5 mm, resin thickness shall not be less than 3mm.
金属艺术品材料厚度室内不得低于1.5mm,树脂壁厚度不得低于3mm。
- 6、 Resin artwork surface color guarantee does not fade. 树脂艺术品表面颜色保证不褪色。
- 7、 Seamless metal joints, bending polished smooth. 金属接缝处无缝隙, 折弯处打磨光滑。
- 8、 摆件雕塑必须牢固、稳定、安全、与灯光很好结合。
- 9、 石材基座必须做好加重加固, 以防碰撞引起倒掉。
- 10、 落地安放艺术品要稳、安全。

平面图

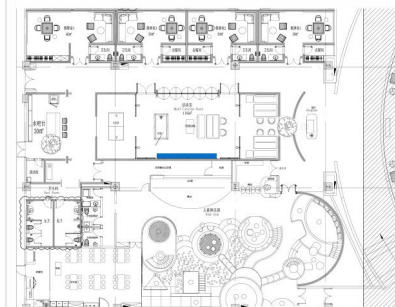

图片仅供参考, 以最终效果为准。

注:

- 1、 实际艺术品以中标单位现场核实具体尺寸数量再深化为准;
- 2、 此点位需灯光照亮, 需灯光顾问配合处理;
- 3、 红框为加固区域, 需墙面加固厚度18mm木工板。

Project 项目名称: 杭州天目山格芮精选希尔顿酒店 Serial number 项目编号: 1F-WS-07

Material 材质: 陶瓷+真书书籍+书挡+仿真绿植+托盘

Process description 工艺说明:

区域: 一层电玩室吧台

Number

数量: 1组

Size

尺寸: 详见清单



Furnishing articles and sculpture process requirements

摆件及雕塑工艺要求

1、 Art as the main theme, style, the main form of expression, need to have a strong visual impact

艺术品作为主题思想、风格的主要表现形式, 需要具有很强的视觉冲击力。

2、 First, the designer confirmed the design, selected processing materials

首先草图, 效果图由设计师确认, 选定加工材料。

3、 According to the site, to determine the size of the sculpture. 根据现场, 图纸确定雕塑、摆件大小尺寸。

4、 Make mud draft, foam model, confirm the overall effect. 制作泥稿、泡沫模型, 确认整体效果。

5、 Indoor metal art material thickness shall not be less than 1.5 mm, resin thickness shall not be less than 3mm.

金属艺术品材料壁厚室内不得低于1.5mm,树脂壁厚不得低于3mm。

6、 Resin artwork surface color guarantee does not fade. 树脂艺术品表面颜色保证不褪色。

7、 Seamless metal joints, bending polished smooth. 金属接缝处无缝隙, 折弯处打磨光滑。

8、 摆件雕塑必须牢固、稳定、安全、与灯光很好结合。

9、 石材基座必须做好加重加固, 以防碰撞引起倒掉。

10、 落地安放艺术品要稳、安全。

平面图

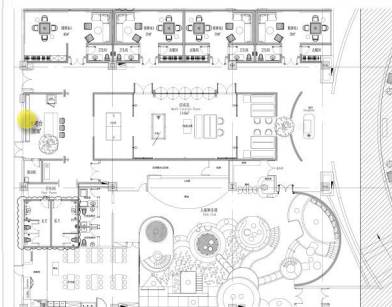

注:

- 1、 实际艺术品以中标单位现场核实具体尺寸数量再深化为准;
- 2、 此点位需灯光照亮, 需灯光顾问配合处理。

图片仅供参考, 以最终效果为准。



茧

以**茧**为灵感来源，保护与孕育，它像一个安全的庇护所，保护着幼虫的成长和发育，寓意着对生命的呵护和孕育新生命的过程。生命的循环，展示了生命不断变化和发展的循环过程，

TAKING THE COCOON AS A SOURCE OF INSPIRATION, IT PROTECTS AND NURTURES LIKE A SAFE SHELTER, PROTECTING THE GROWTH AND DEVELOPMENT OF LARVAE, SYMBOLIZING THE CARE FOR LIFE AND THE PROCESS OF NURTURING NEW LIFE. THE CYCLE OF LIFE DEMONSTRATES THE PROCESS OF CONTINUOUS CHANGE AND DEVELOPMENT OF LIFE,

Project 项目名称: 杭州天目山格芮精选希尔顿酒店 Serial number 项目编号: 1F-RE-01

Material 材质: 表面藤编和金属丝缠绕 (喷哑光漆) + 金属框架+预埋件 + 安装配件

Process description 工艺说明:

区域: 一层团客接待

Number

数量: 1组

Size

尺寸: W13100*D8510*H3800

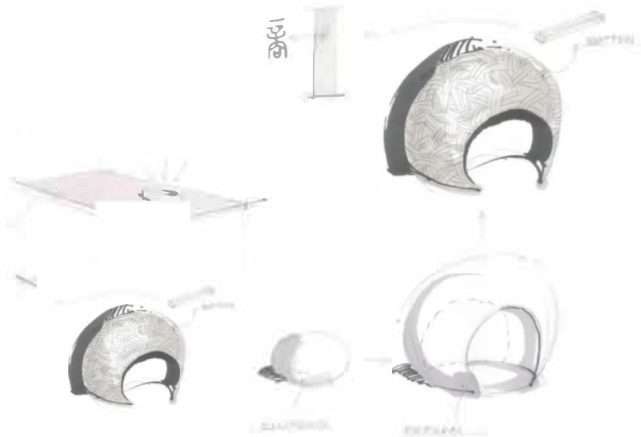

灵感来源: 茧

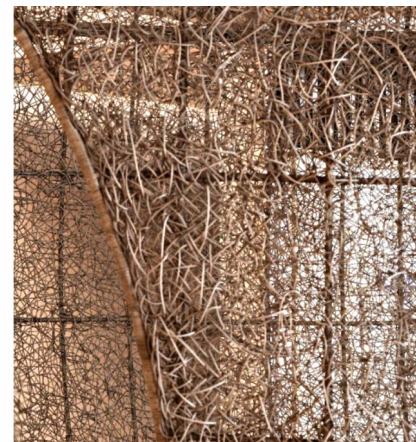

表面藤编和金属丝缠绕效果示意

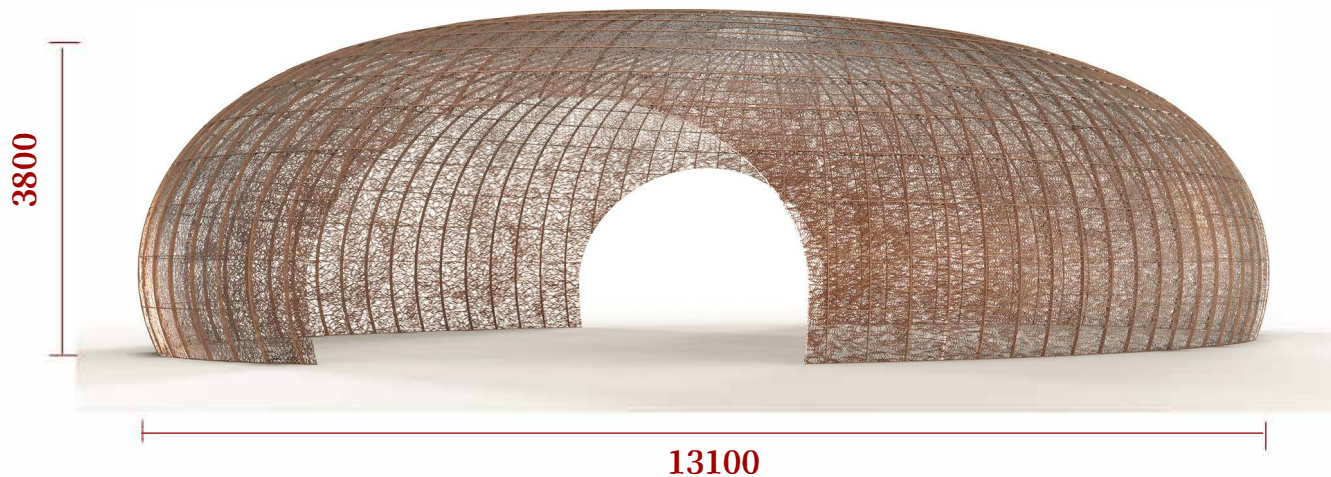

3800

13100

8510

Furnishing articles and sculpture process requirements

摆件及雕塑工艺要求

1、 Art as the main theme, style, the main form of expression, need to have a strong visual impact

艺术品作为主题思想、风格的主要表现形式, 需要具有很强的视觉冲击力。

2、 First, the designer confirmed the design, selected processing materials.

首先草图, 效果图由设计师确认, 选定加工材料。

3、 According to the site, to determine the size of the sculpture. 根据现场, 图纸确定雕塑、摆件大小尺寸。

4、 Make mud draft, foam model, confirm the overall effect. 制作泥稿、泡沫模型, 确认整体效果。

5、 Indoor metal art material thickness shall not be less than 1.5 mm, resin thickness shall not be less than 3mm.

金属艺术品材料厚度室内不得低于1.5mm, 树脂厚度不得低于3mm。

6、 Resin artwork surface color guarantee does not fade. 树脂艺术品表面颜色保证不褪色。

7、 Seamless metal joints, bending polished smooth. 金属接缝处无缝隙, 折弯处打磨光滑。

8、 摆件雕塑必须牢固、稳定、安全、与灯光很好结合。

9、 石材基座必须做好加重加固, 以防碰撞引起倒塌。

10、 落地安放艺术品要稳、安全。

平面图

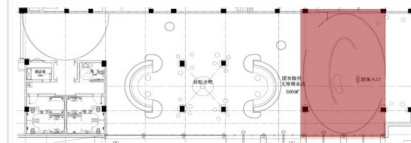

图片仅供参考, 以最终效果为准。

注: 1、实际艺术品以中标单位现场核实具体尺寸数量再深化为准;
2、此点位需灯光照亮, 需灯光顾问配合处理。

Project 项目名称: 杭州天目山格芮精选希尔顿酒店 Serial number 项目编号: 1F-RE-01

Material 材质: 表面藤编和金属丝缠绕 (喷哑光漆) +金属框架+预埋件 +安装配件

Process description 工艺说明:

区域: 一层团客接待

Number

数量: 1组

Size

尺寸: W13100*D8510*H3800

侧视图:

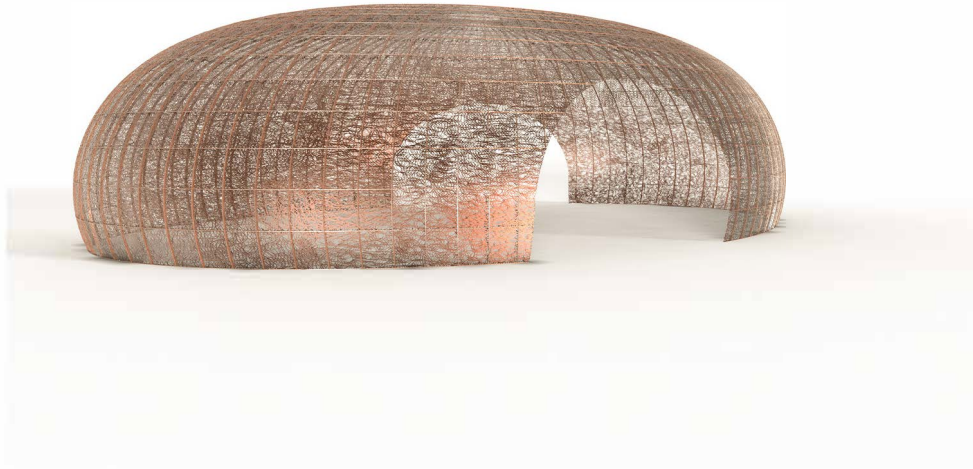

顶视图:



顶视图:



顶视图:



Furnishing articles and sculpture process requirements

摆件及雕塑工艺要求

- 1、 Art as the main theme, style, the main form of expression, need to have a strong visual impact
艺术品作为主题思想、风格的主要表现形式, 需要具有很强的视觉冲击力。
- 2、 First, the designer confirmed the design, selected processing materials.
首先草图, 效果图由设计师确认, 选定加工材料。
- 3、 According to the site, to determine the size of the sculpture.
根据现场, 图纸确定雕塑、摆件大小尺寸。
- 4、 Make mud draft, foam model, confirm the overall effect.
制作泥稿、泡沫模型, 确认整体效果。
- 5、 Indoor metal art material thickness shall not be less than 1.5 mm, resin thickness shall not be less than 3mm.
金属艺术品材料厚度室内不得低于1.5mm,树脂壁厚度不得低于3mm。
- 6、 Resin artwork surface color guarantee does not fade.
树脂艺术品表面颜色保证不褪色。
- 7、 Seamless metal joints, bending polished smooth.
金属接缝处无缝隙, 折弯处打磨光滑。
- 8、 摆件雕塑必须牢固、稳定、安全、与灯光很好结合。
- 9、 石材基座必须做好加重加固, 以防碰撞引起倒掉。
- 10、 落地安放艺术品要稳、安全。

平面图

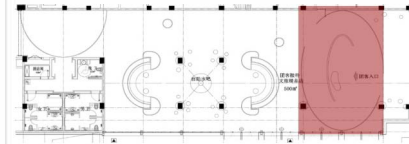

图片仅供参考, 以最终效果为准。

注: 1、实际艺术品以中标单位现场核实具体尺寸数量再深化为准;
2、此点位需灯光照亮, 需灯光顾问配合处理。

Project 项目名称: 杭州天目山格芮精选希尔顿酒店 Serial number 项目编号: 1F-RE-01

Material 材质: 表面藤编和金属丝缠绕 (喷哑光漆) + 金属框架+预埋件 + 安装配件

Process description 工艺说明:

Area 区域: 一层团客接待

Number 数量: 1组

Size 尺寸: W13100*D8510*H3800

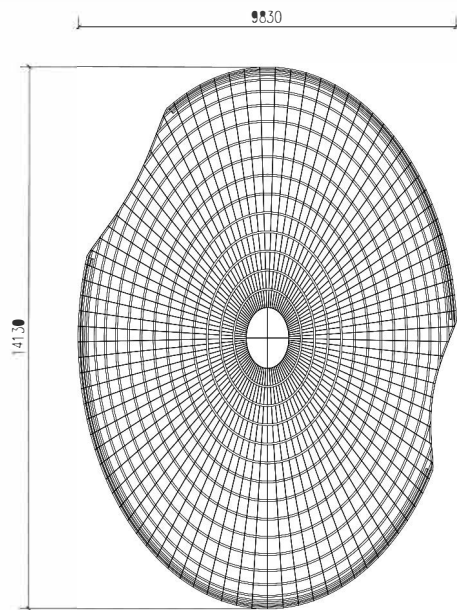

装置平面图 1:100

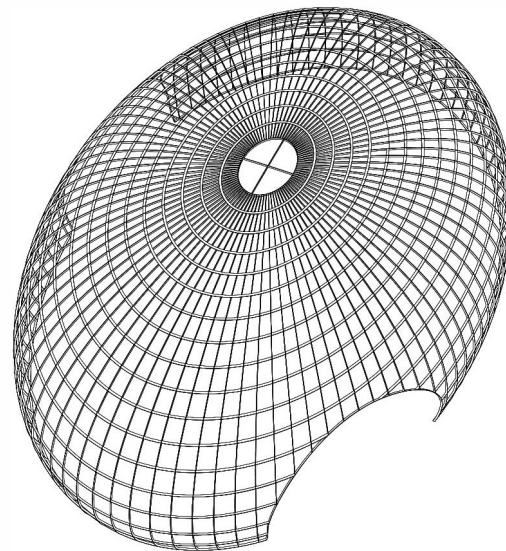

装置透视图

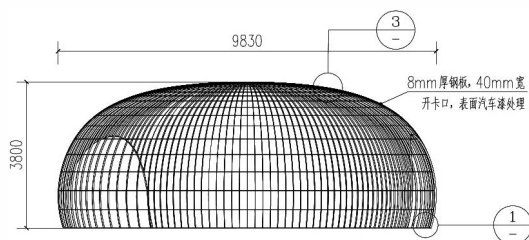

装置正立面图 1:100

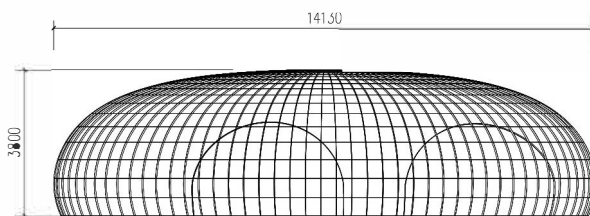

装置侧立面图 1:100

Furnishing articles and sculpture process requirements

摆件及雕塑工艺要求

- 1、Art as the main theme, style, the main form of expression, need to have a strong visual impact
艺术品作为主题思想、风格的主要表现形式, 需要具有很强的视觉冲击力。
- 2、First, the designer confirmed the design, selected processing materials.
首先草图, 效果图由设计师确认, 选定加工材料。
- 3、According to the site, to determine the size of the sculpture.
根据现场, 图纸确定雕塑、摆件大小尺寸。
- 4、Make mud draft, foam model, confirm the overall effect.
制作泥稿、泡沫模型, 确认整体效果。
- 5、Indoor metal art material thickness shall not be less than 1.5 mm, resin thickness shall not be less than 3mm.
金属艺术品材料壁厚室内不得低于1.5mm, 树脂壁厚不得低于3mm。
- 6、Resin artwork surface color guarantee does not fade.
树脂艺术品表面颜色保证不褪色。
- 7、Seamless metal joints, bending polished smooth.
金属接缝处无缝隙, 折弯处打磨光滑。
- 8、摆件雕塑必须牢固、稳定、安全、与灯光很好结合。
- 9、石材基座必须做好加重加固, 以防碰撞引起倒塌。
- 10、落地安放艺术品要稳、安全。

平面图

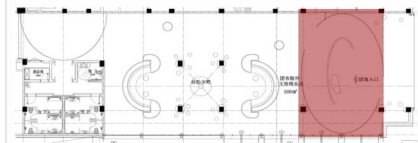

图片仅供参考, 以最终效果为准。

注: 1、实际艺术品以中标单位现场核实具体尺寸数量再深化为准;
2、此点位需灯光照亮, 需灯光顾问配合处理。

Project 项目名称: 杭州天目山格芮精选希尔顿酒店 Serial number 项目编号: 1F-RE-01

Material 材质: 表面藤编和金属丝缠绕 (喷漆光漆) + 金属框架+预埋件 + 安装配件

Process description 工艺说明:

区域: 一层团客接待

Number

数量: 1组

Size 尺寸: W13100*D8510*H3800

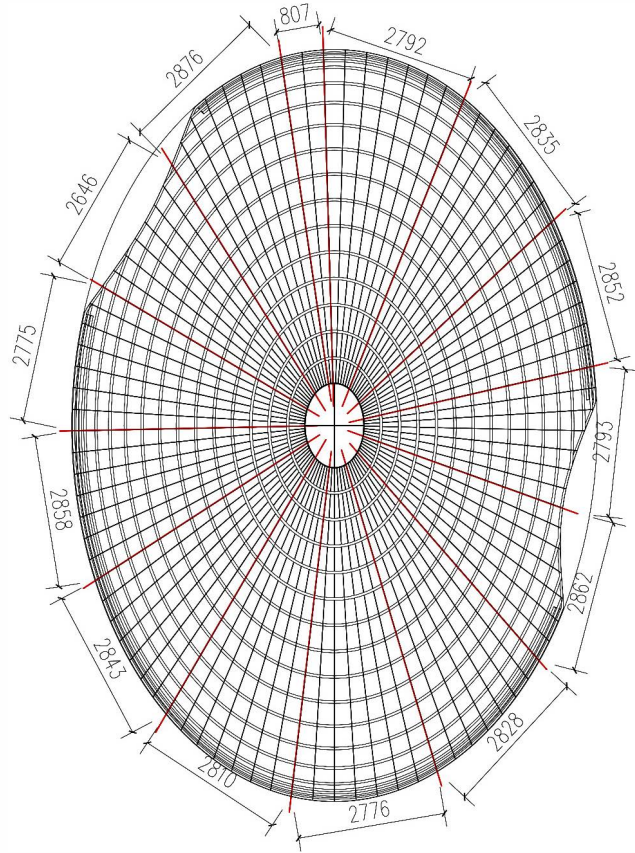

装置分段平面图 1:100

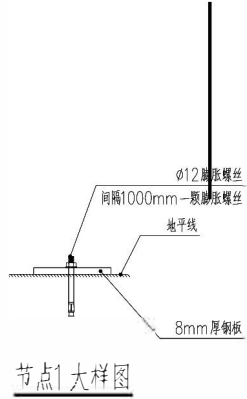

节点1大样图

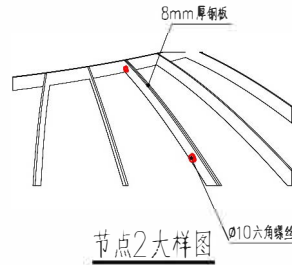

节点2大样图

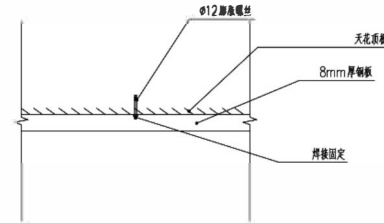

节点3大样图

Furnishing articles and sculpture process requirements

摆件及雕塑工艺要求

- 1、Art as the main theme, style, the main form of expression, need to have a strong visual impact
艺术品作为主题思想、风格的主要表现形式, 需要具有很强的视觉冲击力。
- 2、First, the designer confirmed the design, selected processing materials.
首先草图, 效果图由设计师确认, 选定加工材料。
- 3、According to the site, to determine the size of the sculpture.
根据现场, 图纸确定雕塑、摆件大小尺寸。
- 4、Make mud draft, foam model, confirm the overall effect.
制作泥稿、泡沫模型, 确认整体效果。
- 5、Indoor metal art material thickness shall not be less than 1.5 mm, resin thickness shall not be less than 3mm.
金属艺术品材料壁厚室内不得低于1.5mm, 树脂壁厚度不得低于3mm。
树脂艺术品表面颜色保证不褪色。
- 6、Resin artwork surface color guarantee does not fade.
树脂艺术品表面颜色保证不褪色。
- 7、Seamless metal joints, bending polished smooth.
金属接缝处无缝隙, 折弯处打磨光滑。
- 8、摆件雕塑必须牢固、稳定、安全、与灯光很好结合。
- 9、石材基座必须做好加重加固, 以防碰撞引起倒塌。
- 10、落地安放艺术品要稳、安全。

平面图

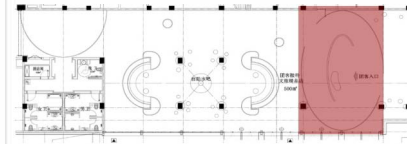

图片仅供参考, 以最终效果为准。

注: 1、实际艺术品以中标单位现场核实具体尺寸数量再深化为准;
2、此点位需灯光照亮, 需灯光顾问配合处理。

Project 项目名称: 杭州天目山格芮精选希尔顿酒店 Serial number 项目编号: 1F-RE-02

Material 材质: 台面木纹饰面+侧面树脂, 内部金属锤纹+金属框架

Process description 工艺说明:

Area 区域: 一层团客接待

Number 数量: 1件

Size 尺寸: W2330*D2330*H2800(总高), 上半部分H1000, 下半部分H1300

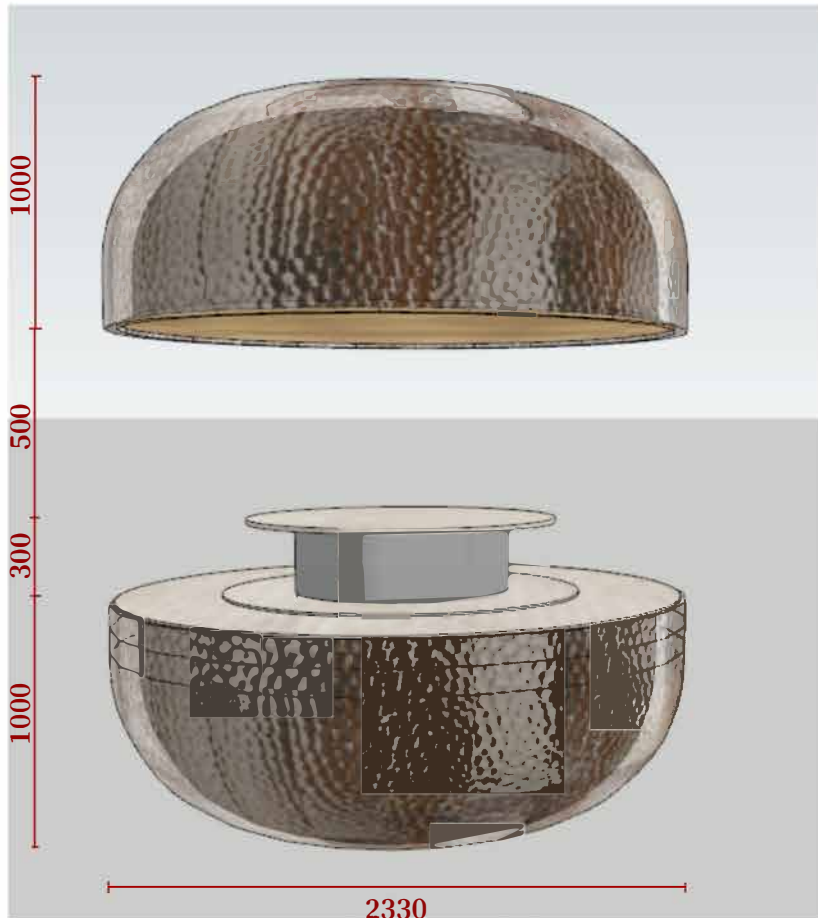

空间位置



材质参考

Furnishing articles and sculpture process requirements

摆件及雕塑工艺要求

1、 Art as the main theme, style, the main form of expression, need to have a strong visual impact

艺术品作为主题思想、风格的主要表现形式, 需要具有很强的视觉冲击力。

2、 First, the designer confirmed the design, selected processing materials.

首先草图, 效果图由设计师确认, 选定加工材料。

3、 According to the site, to determine the size of the sculpture. 根据现场, 图纸确定雕塑、摆件大小尺寸。

4、 Make mud draft, foam model, confirm the overall effect. 制作泥稿、泡沫模型, 确认整体效果。

5、 Indoor metal art material thickness shall not be less than 1.5 mm, resin thickness shall not be less than 3mm.

金属艺术品材料厚度室内不得低于1.5mm, 树脂壁厚厚度不得低于3mm。

6、 Resin artwork surface color guarantee does not fade. 树脂艺术品表面颜色保证不褪色。

7、 Seamless metal joints, bending polished smooth. 金属接缝处无缝隙, 折弯处打磨光滑。

8、 摆件雕塑必须牢固、稳定、安全、与灯光很好结合。

9、 石材基座必须做好加重加固, 以防碰撞引起倒掉。

10、 落地安放艺术品要稳、安全。

平面图

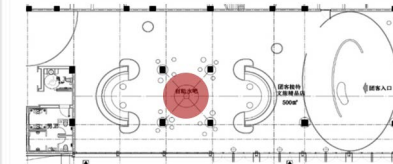

图片仅供参考, 以最终效果为准。

注: 1、实际艺术品以中标单位现场核实具体尺寸数量再深化为准;
2、此点位需灯光照亮, 需灯光顾问配合处理。

Project 项目名称: 杭州天目山格芮精选希尔顿酒店 Serial number 项目编号: 1F-RE-02

Material 材质: 台面木纹饰面+侧面树脂, 内部金属锤纹+金属框架

Process description 工艺说明:

区域: 一层团客接待

Number

数量: 1组

Size

尺寸: W2330*D2330*H2800(总高), 上半部分H1000, 下半部分H1300

透视角度



底面

顶面

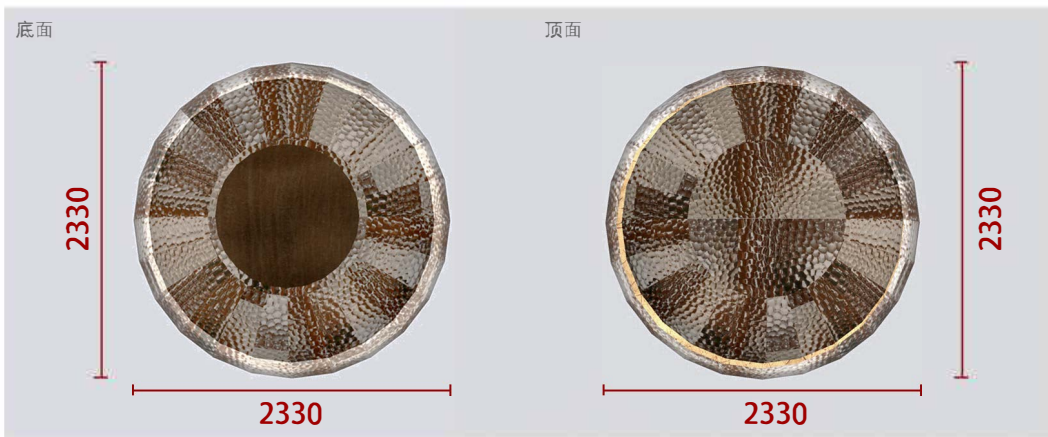

比例效果

Furnishing articles and sculpture process requirements

摆件及雕塑工艺要求

1、 Art as the main theme, style, the main form of expression, need to have a strong visual impact

艺术品作为主题思想、风格的主要表现形式, 需要具有很强的视觉冲击力。

2、 First, the designer confirmed the design, selected processing materials.

首先草图, 效果图由设计师确认, 选定加工材料。

3、 According to the site, to determine the size of the sculpture. 根据现场, 图纸确定雕塑、摆件大小尺寸。

4、 Make mud draft, foam model, confirm the overall effect. 制作泥稿、泡沫模型, 确认整体效果。

5、 Indoor metal art material thickness shall not be less than 1.5 mm, resin thickness shall not be less than 3mm.

金属艺术品材料壁厚室内不得低于1.5mm, 树脂壁厚不得低于3mm。

6、 Resin artwork surface color guarantee does not fade. 树脂艺术品表面颜色保证不褪色。

7、 Seamless metal joints, bending polished smooth. 金属接缝处无缝隙, 折弯处打磨光滑。

8、 摆件雕塑必须牢固、稳定、安全、与灯光很好结合。

9、 石材基座必须做好加重加固, 以防碰撞引起倒掉。

10、 落地安放艺术品要稳、安全。

平面图

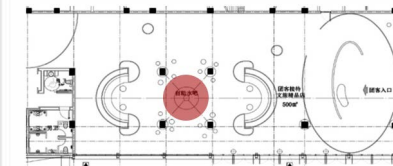

图片仅供参考, 以最终效果为准。

注: 1、实际艺术品以中标单位现场核实具体尺寸数量再深化为准;
2、此点位需灯光照亮, 需灯光顾问配合处理。

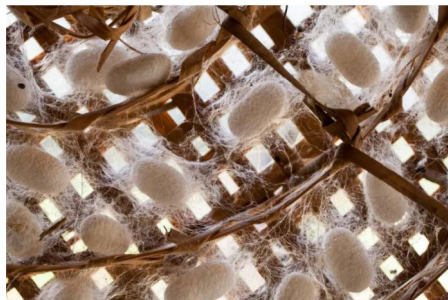

灵感来源: 茧巢, 种子, 孕育



材质细节

灵感源自于茧那神秘而独特的形状, 仿佛是从自然的深处孕育而生。看那流畅的线条, 如抽丝剥茧般细腻而灵动, 勾勒出宛如天成的形态, 那茧形的造型, 宛如一个温暖的怀抱, 呵护着其中即将诞生的果实。它既有着静谧的美感, 又散发着一种蓄势待发的力量, 仿佛在寂静中积蓄着能量, 等待着华丽的蜕变。

THE INSPIRATION COMES FROM THE MYSTERIOUS AND UNIQUE SHAPE OF THE COCCOON, AS IF IT IS NURTURED FROM THE DEPTHS OF NATURE.

LOOK AT THE SMOOTH LINES, AS DELICATE AND ABLE AS A COCCOON, OUTLINING A NATURAL FORM, THE COCCOON SHAPED SHAPE IS LIKE A WARM EMBRACE, NURTURING THE FRUIT THAT IS ABOUT TO BE BORN. IT HAS BOTH A SERENE BEAUTY AND A POWER OF READINESS, AS IF ACCUMULATING ENERGY IN SILENCE, WAITING FOR A MAGNIFICENT TRANSFORMATION.

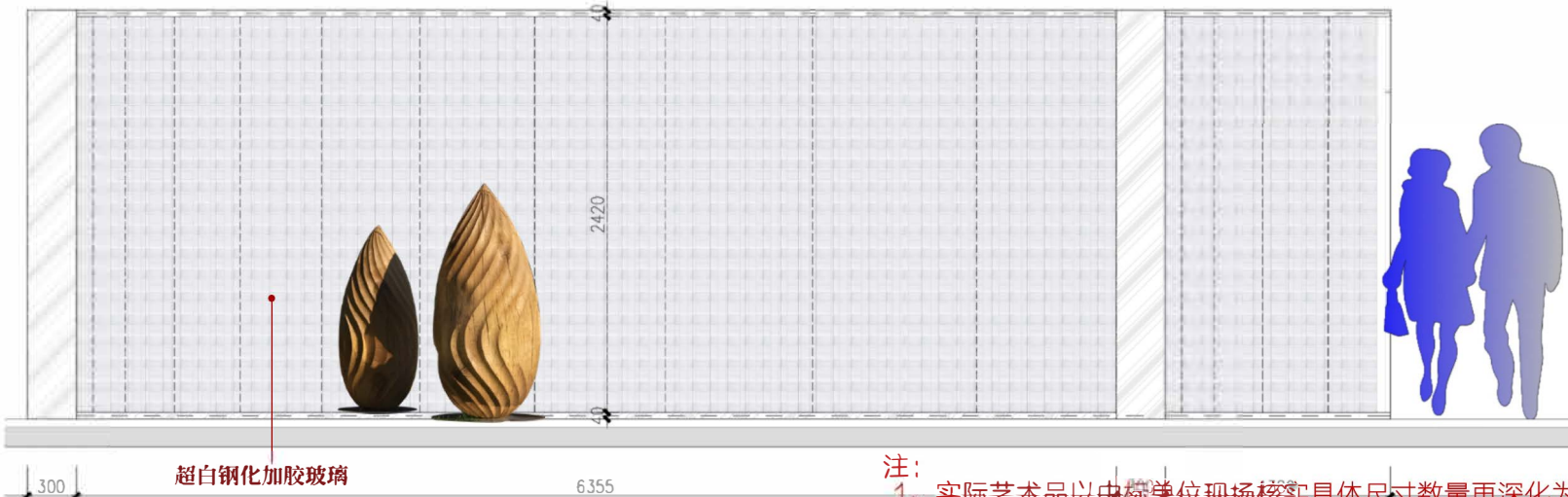

注:

- 1、实际艺术品以中标单位现场核实具体尺寸数量再深化为准;
- 2、此点位需灯光照亮, 需灯光顾问配合处理。
- 3、此艺术品后期摆放进场, 需等过了消防检查。

Furnishing articles and sculpture process requirements

摆件及雕塑工艺要求

1、 Art as the main theme, style, the main form of expression, need to have a strong visual impact

艺术品作为主题思想、风格的主要表现形式, 需要具有很强的视觉冲击力。

2、 First, the designer confirmed the design, selected processing materials.

首先草图, 效果图由设计师确认, 选定加工材料。

3、 According to the site, to determine the size of the sculpture. 根据现场, 图纸确定雕塑、摆件大小尺寸。

4、 Make mud draft, foam model, confirm the overall effect. 制作泥稿、泡沫模型, 确认整体效果。

5、 Indoor metal art material thickness shall not be less than 1.5 mm, resin thickness shall not be less than 3mm.

金属艺术品材料壁厚室内不得低于1.5mm, 树脂壁厚度不得低于3mm。

6、 Resin artwork surface color guarantee does not fade. 树脂艺术品表面颜色保证不褪色。

7、 Seamless metal joints, bending polished smooth. 金属接缝处无缝隙, 折弯处打磨光滑。

8、 摆件雕塑必须牢靠、稳定、安全、与灯光很好结合。

9、 石材基座必须做好加重加固, 以防碰撞引起倒掉。

10、 落地安放艺术品要稳、安全。

平面图

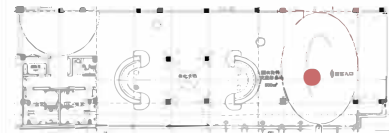

图片仅供参考, 以最终效果为准。

Project 项目名称: 杭州天目山格芮精选希尔顿酒店 Serial number 项目编号: 1F-RE-04

Material 材质: 木质雕刻造型雕塑+黑色金属底座

Process description 工艺说明:

Area 区域: 一层团客接待卫生间

Number 数量: 1件

Size 尺寸: W540*D250*H630

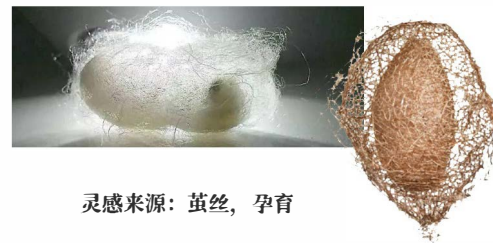
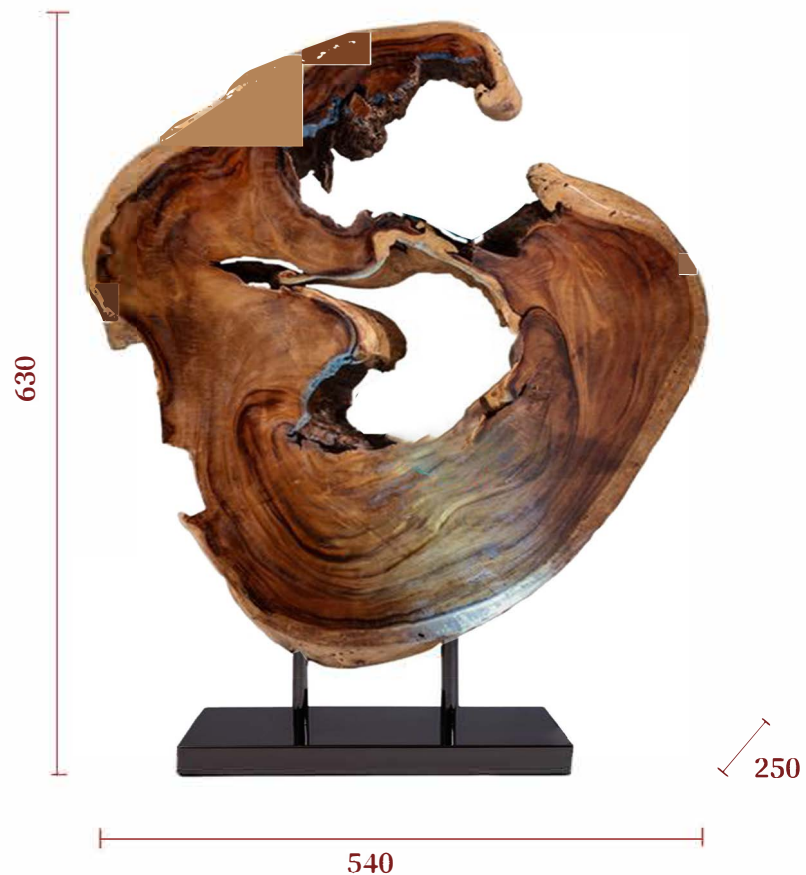

灵感来源: 茧丝, 孕育

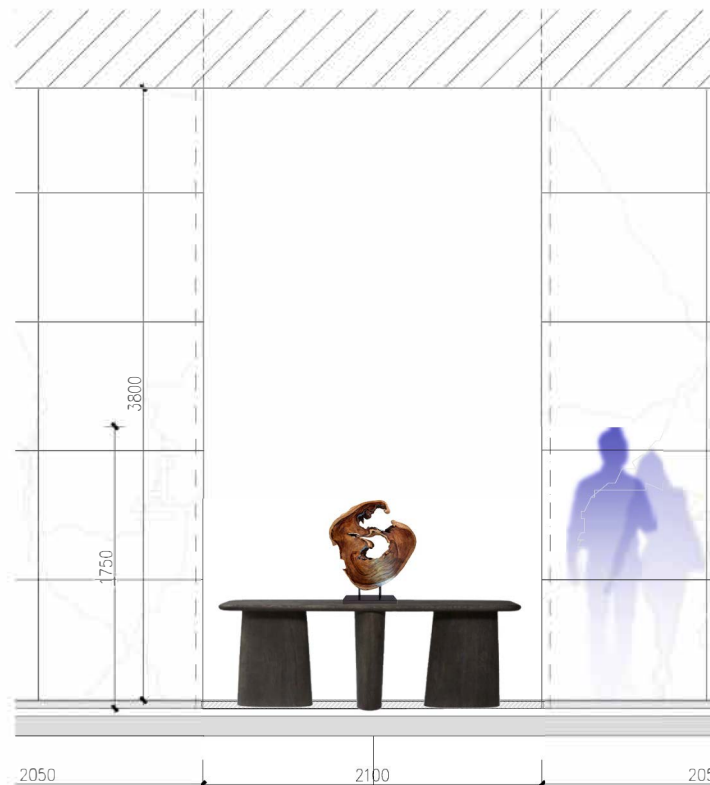

Furnishing articles and sculpture process requirements

摆件及雕塑工艺要求

- 1、Art as the main theme, style, the main form of expression, need to have a strong visual impact
艺术品作为主题思想、风格的主要表现形式, 需要具有很强的视觉冲击力。
- 2、First, the designer confirmed the design, selected processing materials.
首先草图, 效果图由设计师确认, 选定加工材料。
- 3、According to the site, to determine the size of the sculpture.
根据现场, 图纸确定雕塑、摆件大小尺寸。
- 4、Make mud draft, foam model, confirm the overall effect, 制作泥稿、泡沫模型, 确认整体效果。
- 5、Indoor metal art material thickness shall not be less than 1.5 mm, resin thickness shall not be less than 3mm.
金属艺术品材料厚度室内不得低于1.5mm,树脂壁厚度不得低于3mm。
- 6、Resin artwork surface color guarantee does not fade.
树脂艺术品表面颜色保证不褪色。
- 7、Seamless metal joints, bending polished smooth.
金属接缝处无缝隙, 折弯处打磨光滑。
- 8、摆件雕塑必须牢固、稳定、安全、与灯光很好结合。
- 9、石材基座必须做好加重加固, 以防碰撞引起倒掉。
- 10、落地安放艺术品要稳、安全。

平面图

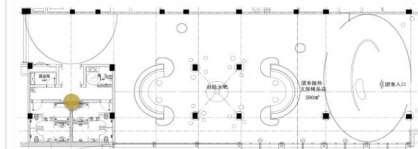

图片仅供参考, 以最终效果为准。

- 注:
- 1、实际艺术品以中标单位现场核实具体尺寸数量再深化为准;
 - 2、此点位需灯光照亮, 需灯光顾问配合处理。

悬浮森林



在那神秘的所在，悬浮森林宛如梦幻之境展现在眼前。葱郁的树木像是从天际垂下的绿色帷幕，它们的枝干交织在一起，仿佛编织着一个绿色的童话。阳光透过树叶的缝隙洒下，形成斑驳而迷离的光影，如金色的丝线在林间舞动。

IN THAT MYSTERIOUS PLACE, THE SUSPENDED FOREST UNFOLDS BEFORE YOUR EYES LIKE A DREAM. THE LUSH TREES ARE LIKE GREEN CURTAINS HANGING FROM THE SKY, AND THEIR BRANCHES ARE INTERTWINED, AS IF WEAVING A GREEN FAIRY TALE. THE SUNLIGHT SHINES THROUGH THE GAPS IN THE LEAVES, FORMING MOTTLED AND BLURRED LIGHT AND SHADOW, LIKE GOLDEN THREADS DANCING IN THE FOREST.



灵感来源: 悬浮森林



材质细节: 金属吊线+颜料块

走进悬浮森林, 仿佛踏入了一个与世隔绝的世界, 时间在这里仿佛也放慢了脚步。仰头望去, 树冠层层叠叠, 向着天空伸展, 仿佛要触摸那高远的苍穹, 给人以无尽的遐想和对自然的敬畏之情。

WALKING INTO THE SUSPENDED FOREST IS LIKE STEPPING INTO AN ISOLATED WORLD, AND TIME SEEMS TO SLOW DOWN HERE. LOOKING UP, THE TREE CANOPIES ARE LAYERED IN LAYERS, STRETCHING TOWARD THE SKY. IT FEELS LIKE TOUCHING THE HIGH SKY, GIVING PEOPLE ENDLESS REVERIE AND AWE OF NATURE.

注: 1、实际艺术品以中标单位现场核实具体尺寸数量再深化为准;
2、此点位需灯光照亮, 需灯光顾问配合处理。
3、此点位吊饰需天花加固双层18mm木工板。



3000



2200

1900

Furnishing articles and sculpture process requirements

摆件及雕塑工艺要求

1、 Art as the main theme, style, the main form of expression, need to have a strong visual impact

艺术品作为主题思想、风格的主要表现形式, 需要具有很强的视觉冲击力。

2、 First, the designer confirmed the design, selected processing materials.

首先草图, 效果图由设计师确认, 选定加工材料。

3、 According to the site, to determine the size of the sculpture. 根据现场, 图纸确定雕塑、摆件大小尺寸。

4、 Make mud draft, foam model, confirm the overall effect. 制作泥稿、泡沫模型, 确认整体效果。

5、 Indoor metal art material thickness shall not be less than 1.5 mm, resin thickness shall not be less than 3mm.

金属艺术品材料壁厚室内不得低于1.5mm,树脂壁厚不得低于3mm。

6、 Resin artwork surface color guarantee does not fade. 树脂艺术品表面颜色保证不褪色。

7、 Seamless metal joints, bending polished smooth. 金属接缝处无缝隙, 折弯处打磨光滑。

8、 摆件雕塑必须牢固、稳定、安全、与灯光很好结合。

9、 石材基座必须做好加固, 以防碰撞引起倒塌。

10、落地安放艺术品要稳、安全。

平面图

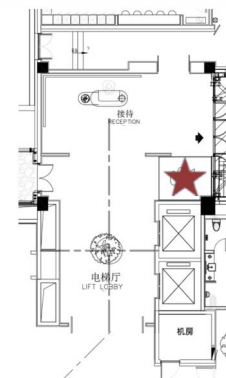

图片仅供参考, 以最终效果为准。

Project 项目名称: 杭州天目山格芮精选希尔顿酒店 Serial number 项目编号: 1F-DT-01

Material 材质: 顶部金属结构网+金属吊线+颜料块

Process description 工艺说明:

区域: 一层电梯厅

Number

数量: 1组

Size

尺寸: W2200*D1900*H3000

Furnishing articles and sculpture process requirements

摆件及雕塑工艺要求

- 1、Art as the main theme, style, the main form of expression, need to have a strong visual impact
艺术品作为主题思想、风格的主要表现形式, 需要具有很强的视觉冲击力。
- 2、First, the designer confirmed the design, selected processing materials.
首先草图, 效果图由设计师确认, 选定加工材料。
- 3、According to the site, to determine the size of the sculpture.
根据现场, 图纸确定雕塑、摆件大小尺寸。
- 4、Make mud draft, foam model, confirm the overall effect.
制作泥稿、泡沫模型, 确认整体效果。
- 5、Indoor metal art material thickness shall not be less than 1.5 mm, resin thickness shall not be less than 3mm.
金属艺术品材料厚度室内不得低于1.5mm, 树脂厚度不得低于3mm。
- 6、Resin artwork surface color guarantee does not fade.
树脂艺术品表面颜色保证不褪色。
- 7、Seamless metal joints, bending polished smooth.
金属接缝处无缝隙, 折弯处打磨光滑。
- 8、摆件雕塑必须牢固、稳定、安全、与灯光很好结合。
- 9、石材基座必须做好加重加固, 以防碰撞引起倒掉。
- 10、落地安放艺术品要稳、安全。

平面图

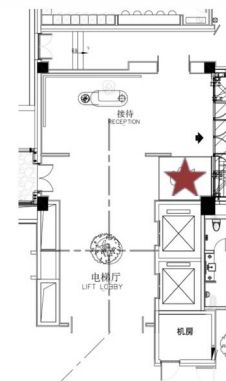

图片仅供参考, 以最终效果为准。

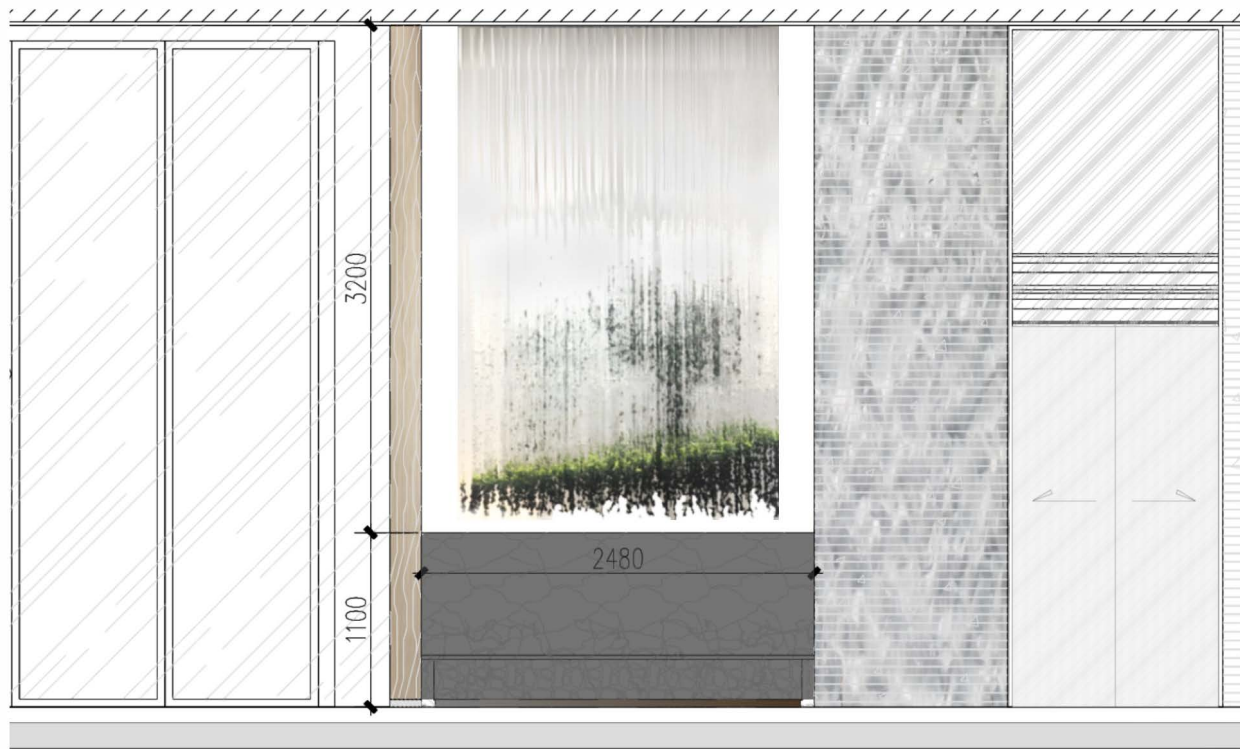
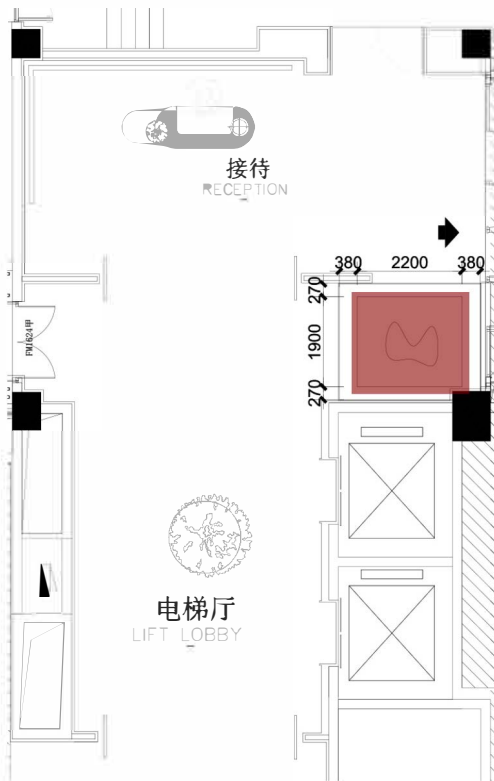

- 注: 1、实际艺术品以中标单位现场核实具体尺寸数量再深化为准;
2、此点位需灯光照亮, 需灯光顾问配合处理。
3、此点位吊饰需天花加固双层18mm木工板。



天目山拥有世界罕见的大柳杉群落，其秋叶颜色丰富多样，除了红色的枫叶，还有金色的银杏、橙色的檫、紫色的柏等，共同构成了一幅美丽的秋色画卷。

TIANMU MOUNTAIN HAS A RARE COMMUNITY OF LARGE CYPRESS TREES IN THE WORLD, WITH A RICH VARIETY OF AUTUMN LEAVES. IN ADDITION TO THE RED MAPLE LEAVES, THERE ARE ALSO GOLDEN GINKGO, ORANGE SASSAFRAS, PURPLE CYPRESSES, ETC., WHICH TOGETHER FORM A BEAUTIFUL AUTUMN PAINTING.

Project 项目名称: 杭州天目山格芮精选希尔顿酒店 Serial number 项目编号: 1F-DT-02

Material 材质: 表面亚克力喷绘大尺寸叶子图案+底部金属网枫叶

Process description 工艺说明:

Location: 一层电梯厅

Number 数量: 1件

Size 尺寸: φ2000*D50

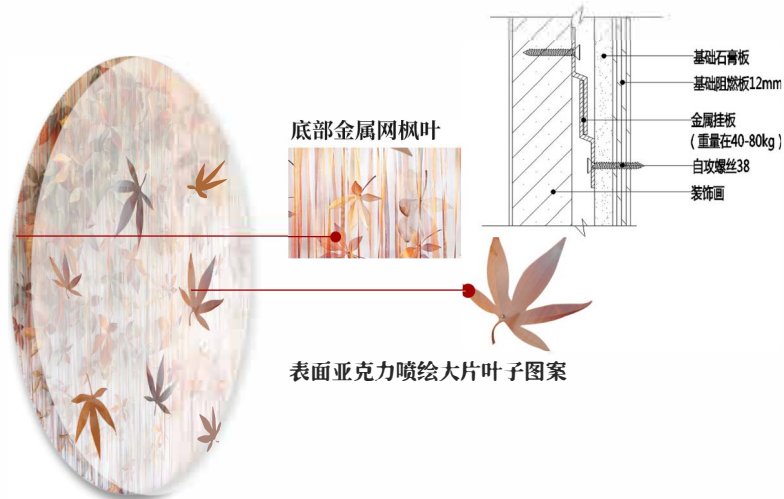

灵感来源: 枫叶



局部细节: 金属网枫叶形状



在这幅挂画中, 一片绚烂的秋景如诗如画般展开。运用底部金属网枫叶形状拼凑的画面加上表面亚克力喷绘的枫叶形状图案形成前后对比。天目山的枫叶宛如燃烧的火焰, 摇曳在画面之中。那一片片枫叶, 它们或轻盈地飘落, 或静静地依附在枝头, 仿佛在诉说着秋天的故事。

IN THIS HANGING PAINTING, A SPLENDID AUTUMN SCENERY UNFOLDS LIKE A POEM OR A PAINTING. THE IMAGE IS PIECED TOGETHER USING THE SHAPE OF MAPLE LEAVES ON THE BOTTOM METAL MESH, AND THE MAPLE LEAF SHAPE PATTERN SPRAYED WITH ACRYLIC ON THE SURFACE FORMS A CONTRAST BEFORE AND AFTER. THE MAPLE LEAVES OF TIANNMU MOUNTAIN ARE LIKE BURNING FLAMES, SWAYING IN THE PICTURE. THE MAPLE LEAVES FALL LIGHTLY OR QUIETLY CLING TO THE BRANCHES, AS IF TELLING THE STORY OF AUTUMN.

Furnishing articles and sculpture process requirements

摆件及雕塑工艺要求

- 1、Art as the main theme, style, the main form of expression, need to have a strong visual impact
艺术品作为主题思想、风格的主要表现形式, 需要具有很强的视觉冲击力。
- 2、First, the designer confirmed the design, selected processing materials.
首先草图, 效果图由设计师确认, 选定加工材料。
- 3、According to the site, to determine the size of the sculpture. 根据现场, 图纸确定雕塑、摆件大小尺寸。
- 4、Make mud draft, foam model, confirm the overall effect. 制作泥稿、泡沫模型, 确认整体效果。
- 5、Indoor metal art material thickness shall not be less than 1.5 mm, resin thickness shall not be less than 3mm.
金属艺术品材料壁厚室内不得低于1.5mm, 树脂壁厚不得低于3mm。
- 6、Resin artwork surface color guarantee does not fade. 树脂艺术品表面颜色保证不褪色。
- 7、Seamless metal joints, bending polished smooth. 金属接缝处无缝隙, 折弯处打磨光滑。
- 8、摆件雕塑必须牢固、稳定、安全、与灯光很好结合。
- 9、石材基座必须做好加重加固, 以防碰撞引起倒掉。
- 10、落地安放艺术品要稳、安全。

平面图

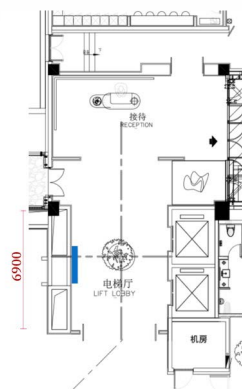

图片仅供参考, 以最终效果为准。

注: 1、实际艺术品以中标单位现场核实具体尺寸数量再深化为准;
2、此点位需灯光照亮, 需灯光顾问配合处理。

Project 项目名称: 杭州天目山格芮精选希尔顿酒店 Serial number 项目编号: 1F-DT-02

Material 材质: 表面亚克力喷绘大尺寸叶子图案+底部金属网枫叶

Process description 工艺说明:

区域: 一层电梯厅

Number 数量: 1件

Size 尺寸: $\phi 2000 \times D50$

Furnishing articles and sculpture process requirements

摆件及雕塑工艺要求

1、Art as the main theme, style, the main form of expression, need to have a strong visual impact

艺术品作为主题思想、风格的主要表现形式, 需要具有很强的视觉冲击力。

2、First, the designer confirmed the design, selected processing materials

首先草图, 效果图由设计师确认, 选定加工材料。

3、According to the site, to determine the size of the sculpture. 根据现场, 图纸确定雕塑、摆件大小尺寸。

4、Make mud draft, foam model, confirm the overall effect. 制作泥稿、泡沫模型, 确认整体效果。

5、Indoor metal art material thickness shall not be less than 1.5 mm, resin thickness shall not be less than 3mm.

金属艺术品材料壁厚室内不得低于1.5mm, 树脂壁厚不得低于3mm。

6、Resin artwork surface color guarantee does not fade. 树脂艺术品表面颜色保证不褪色。

7、Seamless metal joints, bending polished smooth. 金属接缝处无缝隙, 折弯处打磨光滑。

8、摆件雕塑必须牢固、稳定、安全、与灯光很好结合。

9、石材基座必须做好加重加固, 以防碰撞引起倒塌。

10、落地安放艺术品要稳、安全。

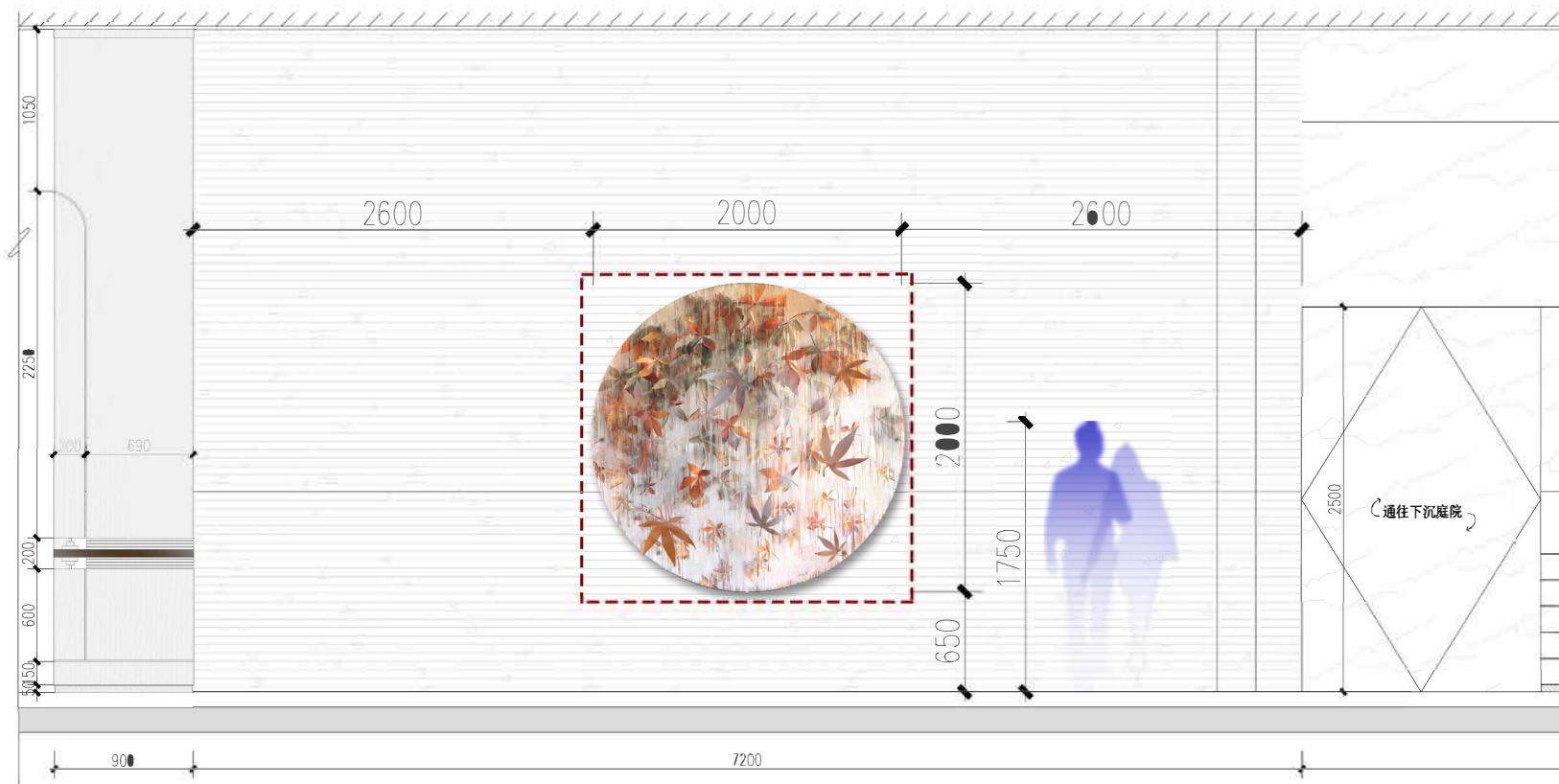

注: 1、实际艺术品以中标单位现场核实具体尺寸数量再深化为准;
2、此点位需灯光照亮, 需灯光顾问配合处理;
3、红圈虚线位置约W2100*H2100, 需墙面预埋18mm木工板加固。

平面图

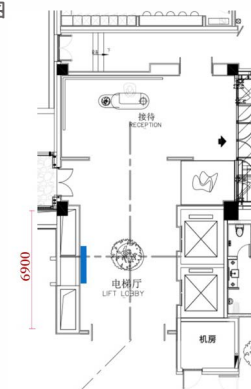

图片仅供参考, 以最终效果为准。

Project 项目名称: 杭州天目山格芮精选希尔顿酒店 Serial number 项目编号: 1F-JS-01

Material 材质: 喷绘画面+木质底板+黑色木框

Process description 工艺说明:

Area 区域: 一层健身房更衣室

Number 数量: 1件

Size 尺寸: W2800*D30*H1200

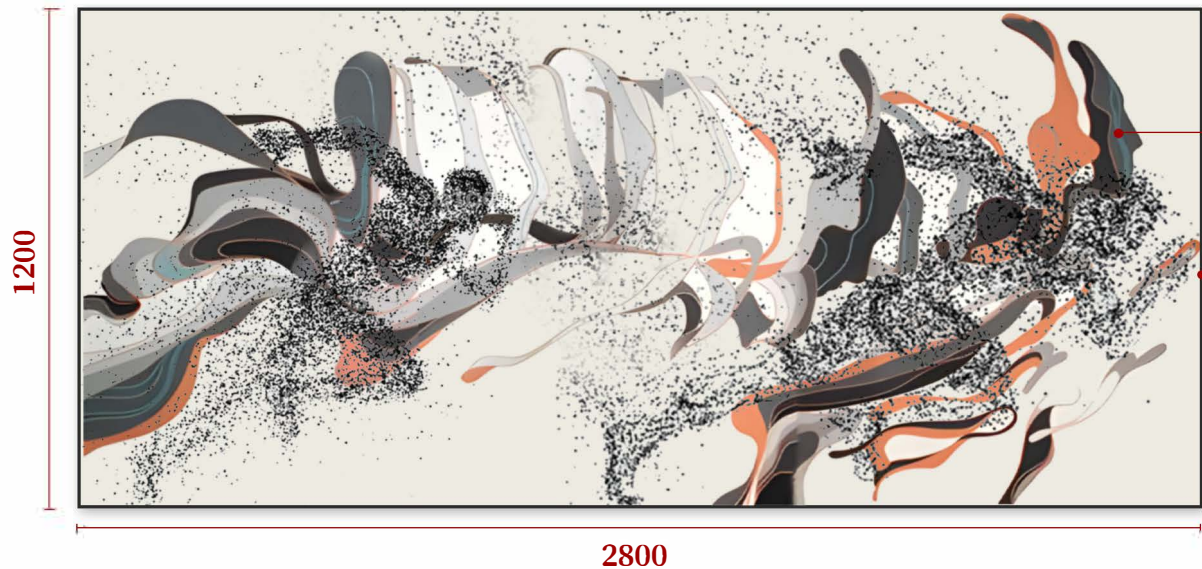

1200

2800

喷绘画面

黑色木框

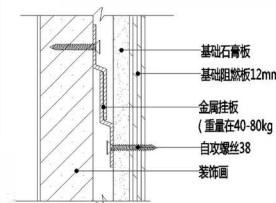

灵感来源: 健身跑步

在那健身房的墙壁上, 一幅挂画宛如灵动的诗篇。那以跑步元素为主体的画面中, 流动的线条似舞动的丝带, 轻盈而飘逸。它们相互交织、缠绕, 勾勒出跑步者身姿的轮廓, 仿佛正在风中疾驰。而跑步的速度在画面中幻化成若隐若现的幻影, 如同风的精灵在追逐着梦想。

ON THE WALL OF THE GYM, THERE IS A PAINTING THAT LOOKS LIKE A LIVELY POEM. IN THE PAINTING WITH RUNNING AS THE MAIN ELEMENT, THE FLOWING LINES ARE LIKE DANCING RIBBONS, LIGHT AND ELEGANT. THEY INTERTWINE AND ENTWINE WITH EACH OTHER, OUTLINING THE OUTLINE OF THE RUNNER'S FIGURE, AS IF HE IS RUNNING IN THE WIND. THE SPEED OF RUNNING TURNS INTO A LOOMING PHANTOM IN THE PAINTING, LIKE A WIND SPIRIT CHASING A DREAM.

注:

- 1、实际艺术品以中标单位现场核具体尺寸数量再深化为准;
- 2、此点位需灯光照亮, 需灯光顾问配合处理。
- 3、红框为加固区域, 需墙面加固厚度18mm木工板。

Furnishing articles and sculpture process requirements

摆件及雕塑工艺要求

- 1、Art as the main theme, style, the main form of expression, need to have a strong visual impact
艺术品作为主题思想、风格的主要表现形式, 需要具有很强的视觉冲击力。
- 2、First, the designer confirmed the design, selected processing materials.
首先草图, 效果图由设计师确认, 选定加工材料。
- 3、According to the site, to determine the size of the sculpture. 根据现场, 图纸确定雕塑、摆件大小尺寸。
- 4、Make mud draft, foam model, confirm the overall effect. 制作泥稿、泡沫模型, 确认整体效果。
- 5、Indoor metal art material thickness shall not be less than 1.5 mm, resin thickness shall not be less than 3mm.
金属艺术品材料壁厚室内不得低于1.5mm, 树脂壁厚度不得低于3mm。
树脂 artwork surface color guarantee does not fade, 树脂艺术品表面颜色保证不褪色。
- 7、Seamless metal joints, bending polished smooth. 金属接缝处无缝隙, 折弯处打磨光滑。
- 8、摆件雕塑必须牢固、稳定、安全、与灯光很好结合。
- 9、石材基座必须做好加重加固, 以防碰撞引起倒掉。
- 10、落地安放艺术品要稳、安全。

平面图

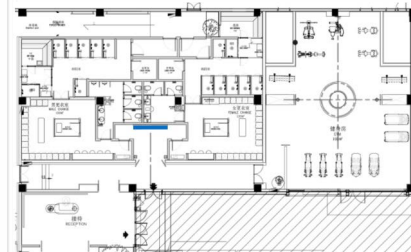

图片仅供参考, 以最终效果为准。

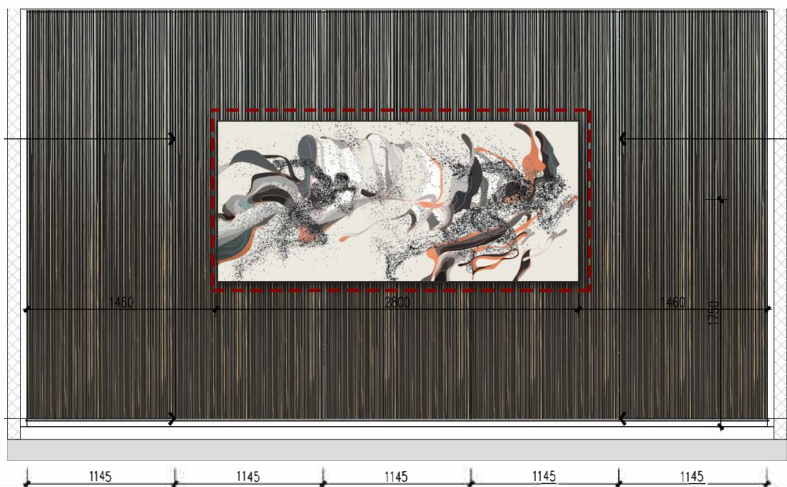

Project 项目名称: 杭州天目山格芮精选希尔顿酒店 Serial number 项目编号: 1F-JS-02

Area 区域: 一层健身房入口

Number 数量: 1组

Material 材质: 永生苔藓+仿真树木+仿真绿植

Size 尺寸: W3800*D2300*H2700

Process description 工艺说明:



白沙砾



永生苔藓

Furnishing articles and sculpture process requirements

摆件及雕塑工艺要求

1、 Art as the main theme, style, the main form of expression, need to have a strong visual impact

艺术品作为主题思想、风格的主要表现形式, 需要具有很强的视觉冲击力。

2、 First, the designer confirmed the design, selected processing materials.

首先草图, 效果图由设计师确认, 选定加工材料。

3、 According to the site, to determine the size of the sculpture. 根据现场, 图纸确定雕塑、摆件大小尺寸。

4、 Make mud draft, foam model, confirm the overall effect. 制作泥稿、泡沫模型, 确认整体效果。

5、 Indoor metal art material thickness shall not be less than 1.5 mm, resin thickness shall not be less than 3mm.

金属艺术品材料壁厚室内不得低于1.5mm, 树脂壁厚度不得低于3mm。

6、 Resin artwork surface color guarantee does not fade. 树脂艺术品表面颜色保证不褪色。

7、 Seamless metal joints, bending polished smooth. 金属接缝处无缝隙, 折弯处打磨光滑。

8、 摆件雕塑必须牢固、稳定、安全、与灯光很好结合。

9、 石材基座必须做好加重加固, 以防碰撞引起倒掉。

10、 落地安放艺术品要稳、安全。

平面图

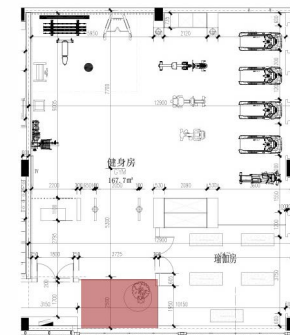

图片仅供参考, 以最终效果为准。

注:

- 1、实际艺术品以中标单位现场核实具体尺寸数量再深化为准;
- 2、此点位需灯光照亮, 需灯光顾问配合处理。



2

二层中餐厅

CHINESE RESTAURANT ON THE SECOND FLOOR

[花园秘境]

Garden Secret

Second floor overall plan

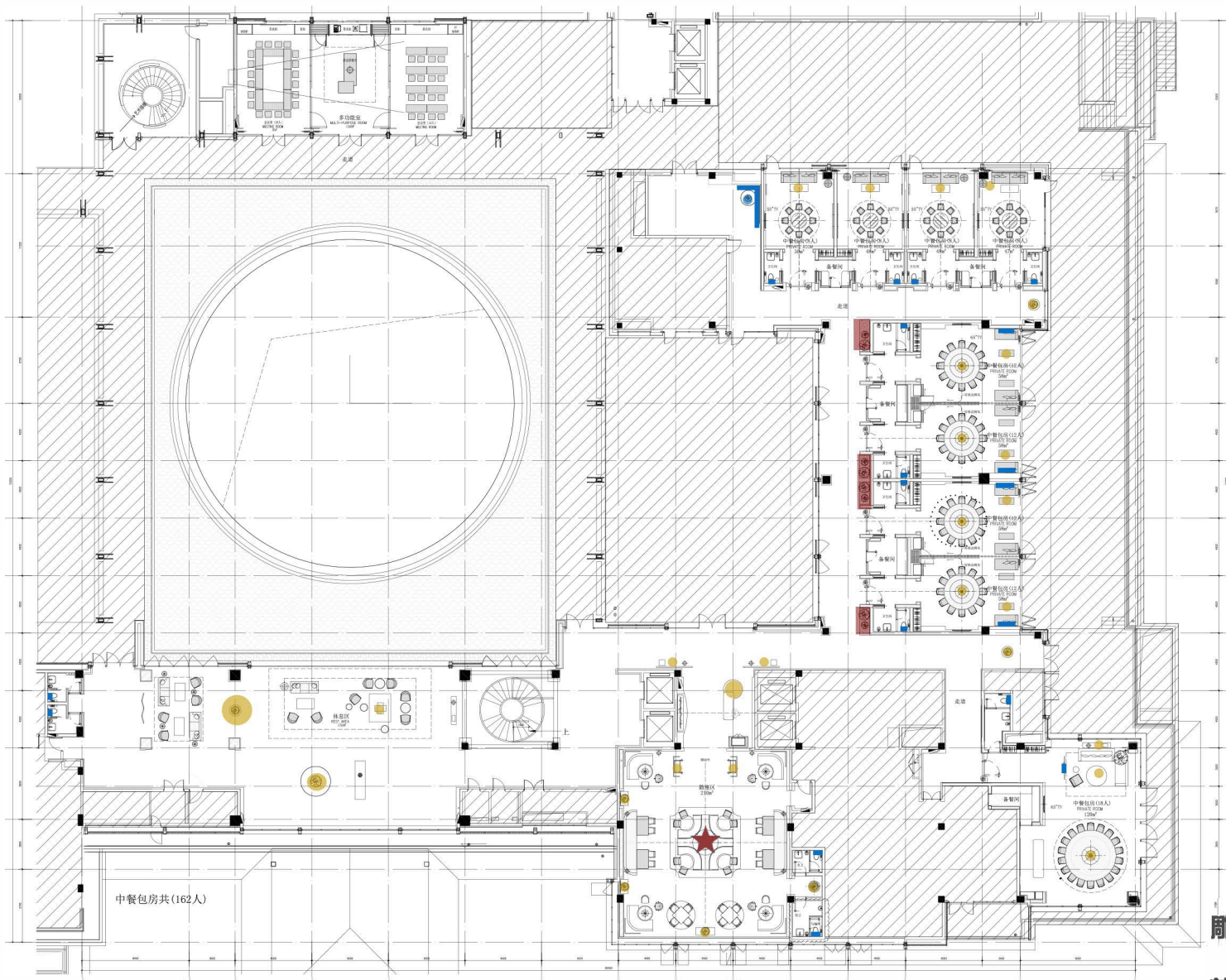

二层总平面

雕塑



A级



挂画



B级



摆件



C级



注：所有艺术品点位位置需要灯光配合

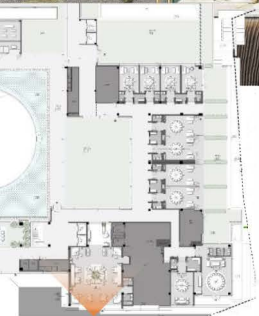

二层中餐厅效果图

SECOND FLOOR CHINESE RESTAURANT RENDERINGS

TIANMU SEA OF FLOWERS



天目玉兰



天目琼花



天目杜鹃花

天目山花海是一个非常受人喜欢的景区, 春天, 夏天, 秋天, 冬天都有花盛开, 春天有满山的杜鹃花, 红艳艳的。夏天水里面都是荷花, 路上种的都是凤仙花, 牵牛花, 喇叭花。非常艳丽。秋天满地的菊花, 白色, 黄色, 紫色。争相夺艳。冬天也有梅花, 红色的, 白色的。在雪中盛开别有一番胜景。

MOST OF THE FLOWERS AND TREES BLOOMING IN EARLY SPRING IN TIANMU MOUNTAIN ARE YELLOW, SUCH AS SASSAFRAS, WITCH HAZEL, PHEASANT PEPPER, JINGJIE FLOWER, DOGWOOD, BREEZE VINE, ETC. WAX PETAL FLOWER IS ALSO ONE OF THEM. MID-MARCH IS THEIR PEAK FLOWERING SEASON. STRINGS OF BRIGHT YELLOW FLOWERS HANG ON THE BRANCHES, LOOKING VERY CONSPICUOUS.



花团锦簇



天目山山间早春开放的花木多为黄色，譬如檫木、金缕梅、山鸡椒、旌节花、山茱萸、清风藤等，蜡瓣花也是其中之一，三月中旬是它们的盛花时节，一串串明黄色的花朵挂于枝头，看起来显眼极了。

MOST OF THE FLOWERS AND TREES BLOOMING IN EARLY SPRING IN TIANMU MOUNTAIN ARE YELLOW, SUCH AS SASSAFRAS, WITCH HAZEL, PHEASANT PEPPER, JINGJIE FLOWER, DOGWOOD, BREEZE VINE, ETC. WAX PETAL FLOWER IS ALSO ONE OF THEM. MID-MARCH IS THEIR PEAK FLOWERING SEASON. STRINGS OF BRIGHT YELLOW FLOWERS HANG ON THE BRANCHES, LOOKING VERY CONSPICUOUS.

Project 项目名称: 杭州天目山格芮精选希尔顿酒店 Serial number 项目编号: 2F-CPR-01

Material 材质: 3D打印艺术造型+喷绘渐变颜色

Process description 工艺说明:

Area 区域: 二层中餐厅散座区

Number 数量: 1件

Size 尺寸: W1000*D800*H1300



取自天目山的蜡瓣花造型,以团簇的形式向上绽放盛开,花瓣展开犹如精致的蝴蝶翅膀,轻盈而柔美。

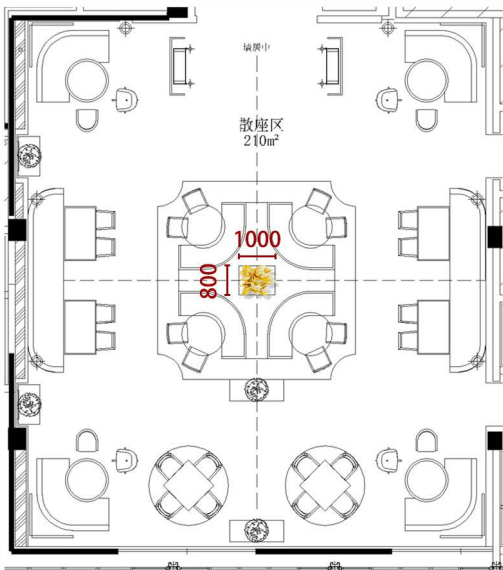

材质细节参考

平面示意



Furnishing articles and sculpture process requirements

摆件及雕塑工艺要求

- 1、Art as the main theme, style, the main form of expression, need to have a strong visual impact
艺术品作为主题思想、风格的主要表现形式,需要具有很强的视觉冲击力。
- 2、First, the designer confirmed the design, selected processing materials.
首先草图,效果图由设计师确认,选定加工材料。
- 3、According to the site, to determine the size of the sculpture.
根据现场,图纸确定雕塑、摆件大小尺寸。
- 4、Make mud draft, foam model, confirm the overall effect.
制作泥稿、泡沫模型,确认整体效果。
- 5、Indoor metal art material thickness shall not be less than 1.5 mm, resin thickness shall not be less than 3mm.
金属艺术品材料厚度室内不得低于1.5mm,树脂厚度不得低于3mm。
- 6、Resin artwork surface color guarantee does not fade.
树脂艺术品表面颜色保证不褪色。
- 7、Seamless metal joints, bending polished smooth.
金属接缝处无缝隙,折弯处打磨光滑。
- 8、摆件雕塑必须牢固、稳定、安全、与灯光很好结合。
- 9、石材基座必须做好加固,以防碰撞引起倒塌。
- 10、落地安放艺术品要稳、安全。

平面图

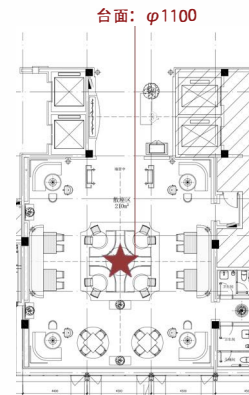

图片仅供参考,以最终效果为准。

注: 1、实际艺术品以中标单位现场核实具体尺寸数量再深化为准;
2、此点位需灯光照亮,需灯光顾问配合处理。

Project 项目名称: 杭州天目山格芮精选希尔顿酒店 Serial number 项目编号: 2F-CPR-02

Material 材质: 陶瓷+表面肌理效果

Process description 工艺说明:

Area 区域: 二层中餐厅散座区

Number 数量: 2件

Size 尺寸: W435*H400.W400*H450



灵感来源:

以抽象的花朵为元素, 以其独特的艺术魅力, 为空间注入了一种梦幻般的诗意氛围, 凸起的肌理效果增添艺术感。

USING ABSTRACT FLOWERS AS ELEMENTS AND THEIR UNIQUE ARTISTIC CHARM, INJECTING A DREAMLIKE POETIC ATMOSPHERE INTO THE SPACE, THE RAISED TEXTURE EFFECT ADDS ARTISTIC SENSE.

底部家具示意:



注: 1、实际艺术品以中标单位现场核实具体尺寸数量再深化为准; 2、此点位需灯光照亮, 需灯光顾问配合处理。

Furnishing articles and sculpture process requirements

摆件及雕塑工艺要求

- 1、Art as the main theme, style, the main form of expression, need to have a strong visual impact
艺术品作为主题思想、风格的主要表现形式, 需要具有很强的视觉冲击力。
- 2、First, the designer confirmed the design, selected processing materials.
首先草图, 效果图由设计师确认, 选定加工材料。
- 3、According to the site, to determine the size of the sculpture. 根据现场, 图纸确定雕塑、摆件大小尺寸。
- 4、Make mud draft, foam model, confirm the overall effect. 制作泥稿、泡沫模型, 确认整体效果。
- 5、Indoor metal art material thickness shall not be less than 1.5 mm, resin thickness shall not be less than 3mm.
金属艺术品材料壁厚室内不得低于1.5mm, 树脂壁厚不得低于3mm。
- 6、Resin artwork surface color guarantee does not fade. 树脂艺术品表面颜色保证不褪色。
- 7、Seamless metal joints, bending polished smooth. 金属接缝处无缝隙, 折弯处打磨光滑。
- 8、摆件雕塑必须牢固、稳定、安全、与灯光很好结合。
- 9、石材基座必须做好加重加固, 以防碰撞引起倒塌。
- 10、落地安放艺术品要稳、安全。

平面图

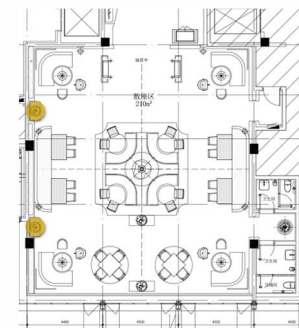

图片仅供参考, 以最终效果为准。



350



灵感来源: 花朵绽放



材质细节

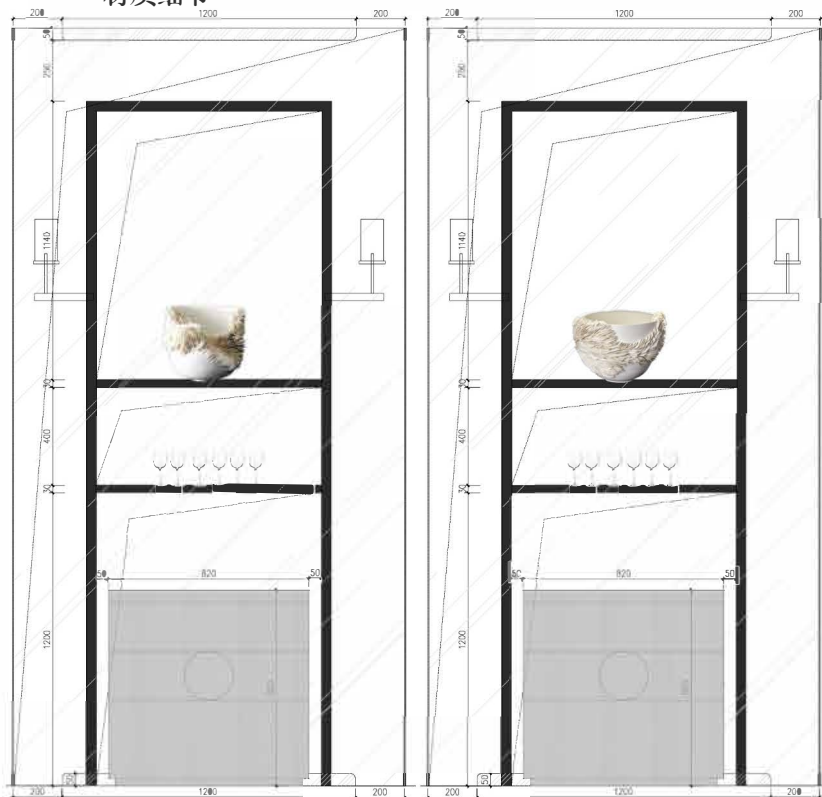

Furnishing articles and sculpture process requirements

摆件及雕塑工艺要求

- 1、Art as the main theme, style, the main form of expression, need to have a strong visual impact
艺术品作为主题思想、风格的主要表现形式, 需要具有很强的视觉冲击力。
- 2、First, the designer confirmed the design, selected processing materials.
首先草图, 效果图由设计师确认, 选定加工材料。
- 3、According to the site, to determine the size of the sculpture. 根据现场, 图纸确定雕塑、摆件大小尺寸。
- 4、Make mud draft, foam model, confirm the overall effect. 制作泥稿、泡沫模型, 确认整体效果。
- 5、Indoor metal art material thickness shall not be less than 1.5 mm, resin thickness shall not be less than 3mm.
金属艺术品材料壁厚室内不得低于1.5mm,树脂壁厚不得低于3mm。
- 6、Resin artwork surface color guarantee does not fade. 树脂艺术品表面颜色保证不褪色。
- 7、Seamless metal joints, bending polished smooth. 金属接缝处无缝隙, 折弯处打磨光滑。
- 8、摆件雕塑必须牢固、稳定、安全、与灯光很好结合。
- 9、石材基座必须做好加重加固, 以防碰撞引起倒掉。
- 10、落地安放艺术品要稳、安全。

平面图

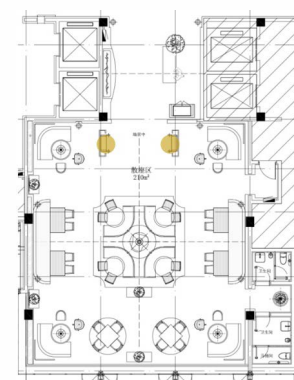

图片仅供参考, 以最终效果为准。

注: 1、实际艺术品以中标单位现场核实具体尺寸数量再深化为准;
2、此点位需灯光照亮, 需灯光顾问配合处理。



600

780



家具款式参考



花器约: $\phi 200 * H230$

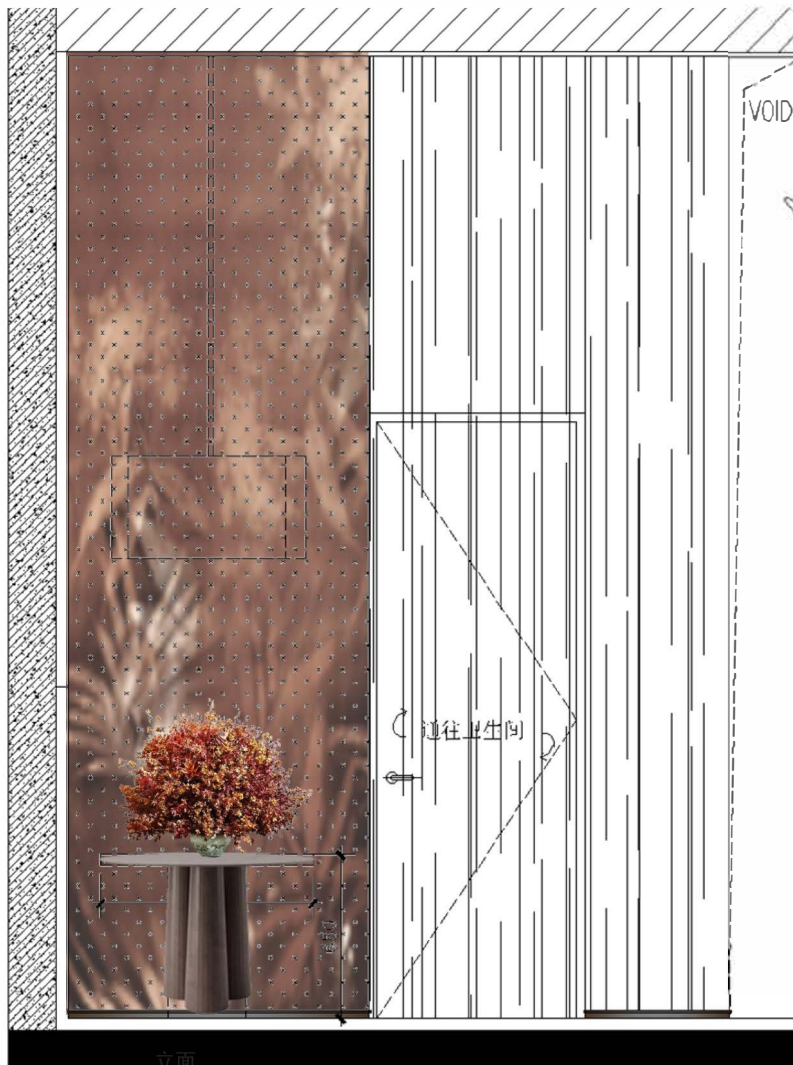

Furnishing articles and sculpture process requirements

摆件及雕塑工艺要求

1、 Art as the main theme, style, the main form of expression, need to have a strong visual impact

艺术品作为主题思想、风格的主要表现形式, 需要具有很强的视觉冲击力。

2、 First, the designer confirmed the design, selected processing materials.

首先草图, 效果图由设计师确认, 选定加工材料。

3、 According to the site, to determine the size of the sculpture. 根据现场, 图纸确定雕塑、摆件大小尺寸。

4、 Make mud draft, foam model, confirm the overall effect. 制作泥稿、泡沫模型, 确认整体效果。

5、 Indoor metal art material thickness shall not be less than 1.5 mm, resin thickness shall not be less than 3mm. 金属艺术品材料厚度室内不得低于1.5mm,树脂厚度不得低于3mm。

6、 Resin artwork surface color guarantee does not fade. 树脂艺术品表面颜色保证不褪色。

7、 Seamless metal joints, bending polished smooth. 金属接缝处无缝隙, 折弯处打磨光滑。

8、 摆件雕塑必须牢固、稳定、安全、与灯光很好结合。

9、 石材基座必须做好加重加固, 以防碰撞引起倒掉。

10、 落地安放艺术品要稳、安全。

平面图

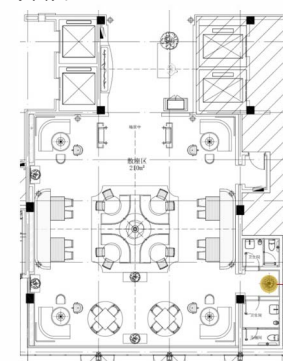

桌面尺寸: $\phi 885$

图片仅供参考, 以最终效果为准。

注: 1、实际艺术品以中标单位现场核实具体尺寸数量再深化为准;
2、此点位需灯光照亮, 需灯光顾问配合处理。

Project 项目名称: 杭州天目山格芮精选希尔顿酒店 Serial number 项目编号: 2F-CPR-05

Material 材质: 木质托盘+真书+永生苔藓+玻璃摆件

Process description 工艺说明:

Area 区域: 二层中餐厅散座区

Number 数量: 1组

Size 尺寸: 详见清单

Furnishing articles and sculpture process requirements

摆件及雕塑工艺要求

1、Art as the main theme, style, the main form of expression, need to have a strong visual impact

艺术品作为主题思想、风格的主要表现形式, 需要具有很强的视觉冲击力。

2、First, the designer confirmed the design, selected processing materials.

首先草图, 效果图由设计师确认, 选定加工材料。

3、According to the site, to determine the size of the sculpture. 根据现场, 图纸确定雕塑、摆件大小尺寸。

4、Make mud draft, foam model, confirm the overall effect. 制作泥稿、泡沫模型, 确认整体效果。

5、Indoor metal art material thickness shall not be less than 1.5 mm, resin thickness shall not be less than 3mm.

金属艺术品材料壁厚室内不得低于1.5mm, 树脂壁厚不得低于3mm。

6、Resin artwork surface color guarantee does not fade. 树脂艺术品表面颜色保证不褪色。

7、Seamless metal joints, bending polished smooth. 金属接缝处无缝隙, 折弯处打磨光滑。

8、摆件雕塑必须牢固、稳定、安全、与灯光很好结合。

9、石材基座必须做好加重加固, 以防碰撞引起倒掉。

10、落地安放艺术品要稳、安全。



硬装家具尺寸: W1500*D450*H850

注: 1、实际艺术品以中标单位现场核实具体尺寸数量再深化为准;
2、此点位需灯光照亮, 需灯光顾问配合处理。

平面图

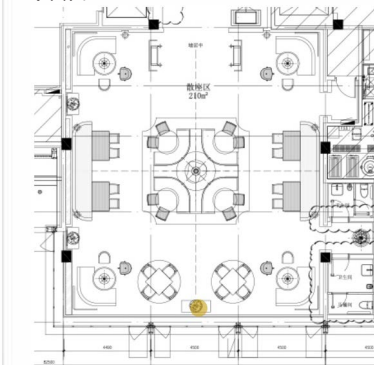

图片仅供参考, 以最终效果为准。



二层中餐厅包房效果图

SECOND FLOOR CHINESE RESTAURANT PRIVATE ROOM RENDERINGS

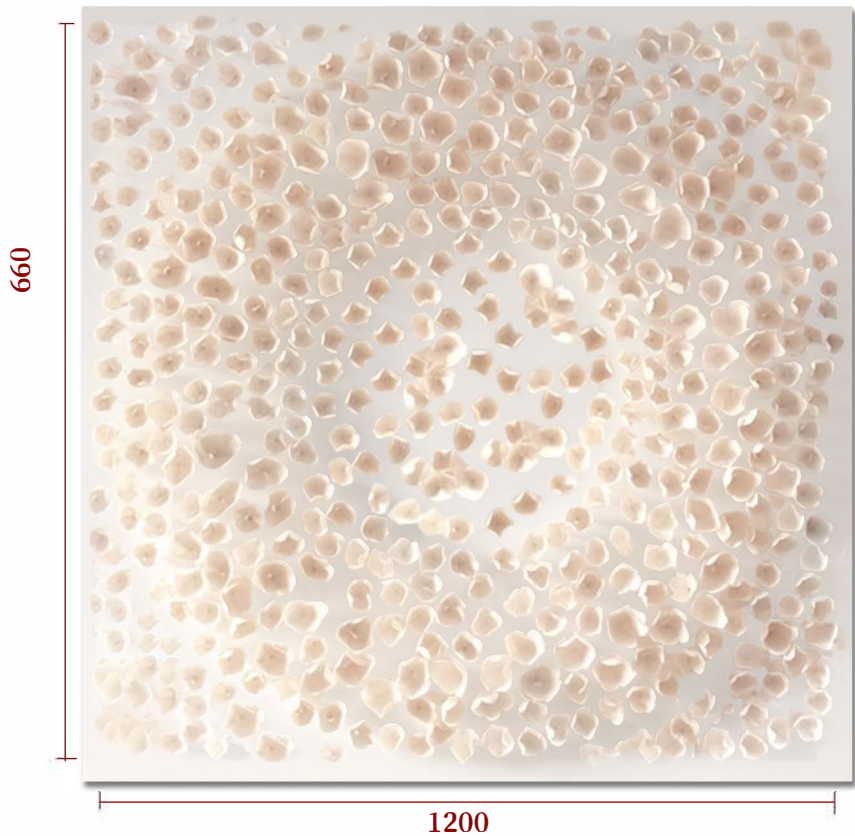

每一片花瓣仿佛是从梦境中走来的精灵，
翩翩起舞，散发着迷人的光彩。每一笔、每一划都充满了激情与创意，
让人在欣赏时不禁陷入遐想。

EACH PETAL IS LIKE AN ELF WALKING FROM A DREAM, DANCING GRACEFULLY AND EMITTING A CHARMING RADIANCE. EVERY STROKE AND STROKE IS FULL OF PASSION AND CREATIVITY, MAKING PEOPLE UNABLE TO RESIST DAYDREAMING WHILE APPRECIATING.

注: 1、实际艺术品以中标单位现场核实具体尺寸数量再深化为准;
2、此点位需灯光照亮, 需灯光顾问配合处理;
3、红框为加固区域, 需墙面加固厚度18mm木工板。

材质细节:



硬装隔断

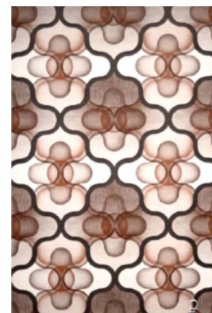

灵感来源: 绽放

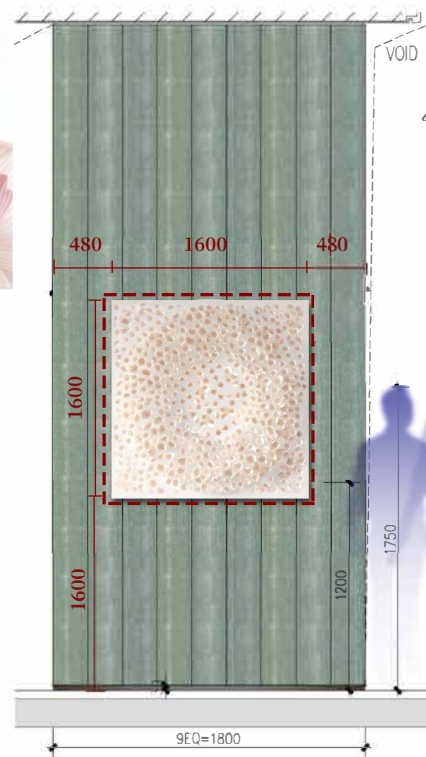
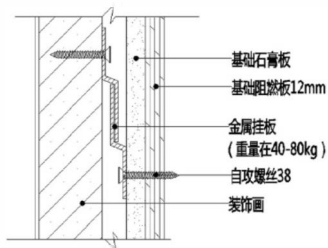

Furnishing articles and sculpture process requirements

摆件及雕塑工艺要求

- 1、Art as the main theme, style, the main form of expression, need to have a strong visual impact
艺术品作为主题思想、风格的主要表现形式, 需要具有很强的视觉冲击力。
- 2、First, the designer confirmed the design, selected processing materials.
首先草图, 效果图由设计师确认, 选定加工材料。
- 3、According to the site, to determine the size of the sculpture. 根据现场, 图纸确定雕塑、摆件大小尺寸。
- 4、Make mud draft, foam model, confirm the overall effect. 制作泥稿、泡沫模型, 确认整体效果。
- 5、Indoor metal art material thickness shall not be less than 1.5 mm, resin thickness shall not be less than 3mm.
金属艺术品材料壁厚室内不得低于1.5mm, 树脂壁厚不得低于3mm。
- 6、Resin artwork surface color guarantee does not fade. 树脂艺术品表面颜色保证不褪色。
- 7、Seamless metal joints, bending polished smooth. 金属接缝处无缝隙, 折弯处打磨光滑。
- 8、摆件雕塑必须牢固、稳定、安全、与灯光很好结合。
- 9、石材基座必须做好加重加固, 以防碰撞引起倒塌。
- 10、落地安放艺术品要稳、安全。

平面图

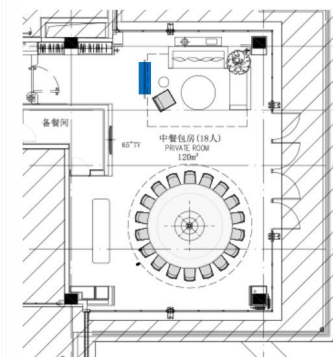

图片仅供参考, 以最终效果为准。

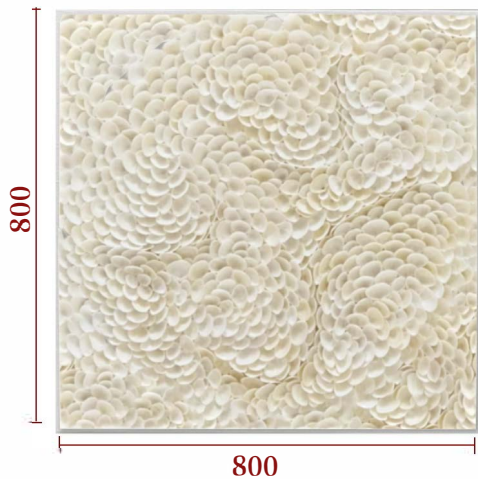

手工陶瓷拼接

白色底板

将花抽象化，用卷曲的形式来体现氛围感，渐变的淡红色和黄色，每一种色彩都散发着独特的魅力，仿佛在诉说着不同的故事。这些色彩交织在一起，构成了一幅和谐的画面，给人一种宁静而舒适，轻盈飘逸，或婉约含蓄的感觉。

ABSTRACT THE FLOWERS AND USE CURLY FORMS TO REFLECT THE ATMOSPHERE, WITH A GRADIENT OF LIGHT RED AND YELLOW, EACH COLOR EMITTING UNIQUE CHARM, AS IF TELLING A DIFFERENT STORY. THESE COLORS INTERWEAVE TOGETHER TO CREATE A HARMONIOUS PICTURE, GIVING PEOPLE A SENSE OF TRANQUILITY AND COMFORT, LIGHTNESS AND ELEGANCE, OR A SUBTLE AND SUBTLE FEELING.

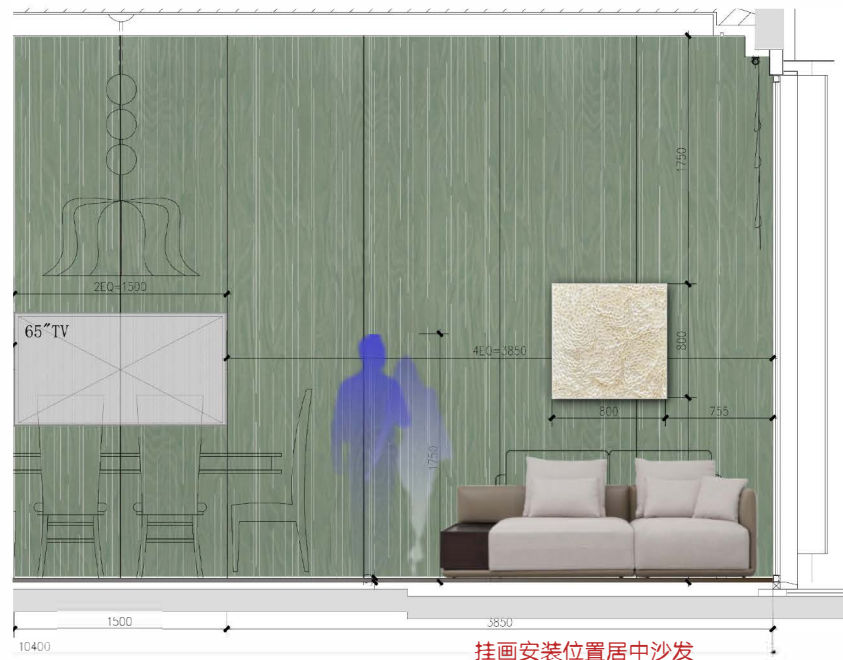

挂画安装位置居中沙发

硬装配色: 隔断及抱枕

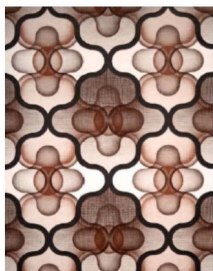

材质细节



Furnishing articles and sculpture process requirements

摆件及雕塑工艺要求

- 1、Art as the main theme, style, the main form of expression, need to have a strong visual impact
艺术品作为主题思想、风格的主要表现形式，需要具有很强的视觉冲击力。
- 2、First, the designer confirmed the design, selected processing materials.
首先草图，效果图由设计师确认，选定加工材料。
- 3、According to the site, to determine the size of the sculpture. 根据现场，图纸确定雕塑、摆件大小尺寸。
- 4、Make mud draft, foam model, confirm the overall effect. 制作泥稿、泡沫模型，确认整体效果。
- 5、Indoor metal art material thickness shall not be less than 1.5 mm, resin thickness shall not be less than 3mm.
金属艺术品材料壁厚室内不得低于1.5mm,树脂壁厚度不得低于3mm。
- 6、Resin artwork surface color guarantee does not fade. 树脂艺术品表面颜色保证不褪色。
- 7、Seamless metal joints, bending polished smooth. 金属接缝处无缝隙，折弯处打磨光滑。
- 8、摆件雕塑必须牢固、稳定、安全、与灯光很好结合。
- 9、石材基座必须做好加重加固，以防碰撞引起倒掉。
- 10、落地安放艺术品要稳、安全。

平面图

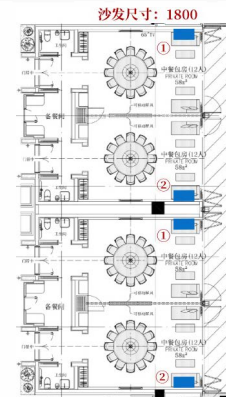

图片仅供参考，以最终效果为准。

注: 1、实际艺术品以中标单位现场核实具体尺寸数量再深化为准;
2、此点位需灯光照亮,需灯光顾问配合处理;

Project 项目名称: 杭州天目山格芮精选希尔顿酒店 Serial number 项目编号: 2F-CPR-08

Material 材质: 陶瓷(跳刀雕刻纹理)

Process description 工艺说明:

Area 区域: 二层中餐厅18人包间

Number 数量: 1件

Size 尺寸: W430*H640



640

430

摆件底部打胶固定

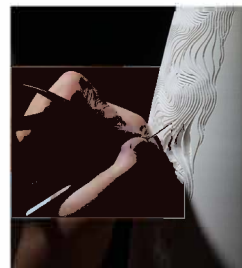

跳刀雕刻纹理



Furnishing articles and sculpture process requirements

摆件及雕塑工艺要求

1、 Art as the main theme, style, the main form of expression, need to have a strong visual impact

艺术品作为主题思想、风格的主要表现形式, 需要具有很强的视觉冲击力。

2、 First, the designer confirmed the design, selected processing materials.

首先草图, 效果图由设计师确认, 选定加工材料。

3、 According to the site, to determine the size of the sculpture. 根据现场, 图纸确定雕塑、摆件大小尺寸。

4、 Make mud draft, foam model, confirm the overall effect. 制作泥稿、泡沫模型, 确认整体效果。

5、 Indoor metal art material thickness shall not be less than 1.5 mm, resin thickness shall not be less than 3mm.

金属艺术品材料壁厚室内不得低于1.5mm, 树脂壁厚不得低于3mm。

6、 Resin artwork surface color guarantee does not fade. 树脂艺术品表面颜色保证不褪色。

7、 Seamless metal joints, bending polished smooth. 金属接缝处无缝隙, 折弯处打磨光滑。

8、 摆件雕塑必须牢固、稳定、安全、与灯光很好结合。

9、 石材基座必须做好加重加固, 以防碰撞引起倒塌。

10、 落地安放艺术品要稳、安全。

平面图

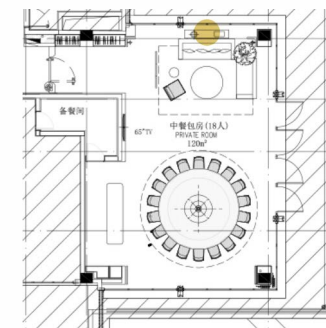

图片仅供参考, 以最终效果为准。

注: 1、实际艺术品以中标单位现场核实具体尺寸数量再深化为准;
2、此点位需灯光照亮, 需灯光顾问配合处理。

Project 项目名称: 杭州天目山格芮精选希尔顿酒店 Serial number 项目编号: 2F-CPR-09

Material 材质: 金属+亚克力摆件+真书书籍+木质花器+永生苔藓+木质托盘 Process description 工艺说明:

Area 区域: 二层中餐厅包间

Number 数量: 9组

Size 尺寸: 详见清单



Furnishing articles and sculpture process requirements

摆件及雕塑工艺要求

1、 Art as the main theme, style, the main form of expression, need to have a strong visual impact

艺术品作为主题思想、风格的主要表现形式, 需要具有很强的视觉冲击力。

2、 First, the designer confirmed the design, selected processing materials.

首先草图, 效果图由设计师确认, 选定加工材料。

3、 According to the site, to determine the size of the sculpture. 根据现场, 图纸确定雕塑、摆件大小尺寸。

4、 Make mud draft, foam model, confirm the overall effect. 制作泥稿、泡沫模型, 确认整体效果。

5、 Indoor metal art material thickness shall not be less than 1.5 mm, resin thickness shall not be less than 3mm.

金属艺术品材料厚度室内不得低于1.5mm,树脂壁厚度不得低于3mm。

6、 Resin artwork surface color guarantee does not fade. 树脂艺术品表面颜色保证不褪色。

7、 Seamless metal joints, bending polished smooth. 金属接缝处无缝隙, 折弯处打磨光滑。

8、 摆件雕塑必须牢固、稳定、安全、与灯光很好结合。

9、 石材基座必须做好加重加固, 以防碰撞引起倒掉。

10、 落地安放艺术品要稳、安全。



12人包间沙发



8人包间沙发



18人包间沙发

平面图

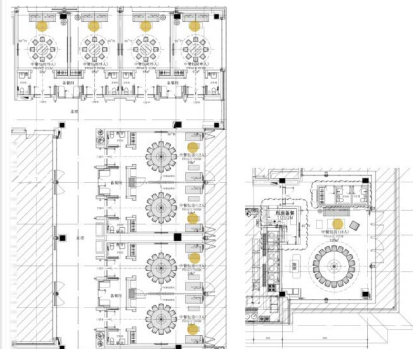

图片仅供参考, 以最终效果为准。

注: 1、实际艺术品以中标单位现场核实具体尺寸数量再深化为准;
2、注意书籍版权问题, 避免涉及政治、宗教等敏感话题。



550

450



以一朵盛开的花朵为主题，框中景象，就像是一扇扇窗户，
让我们能够透过它们，看到更广阔、更美好的世界。

TAKING A BLOOMING FLOWER AS THE THEME, THE
SCENES IN THE FRAME ARE LIKE WINDOWS, ALLOWING US
TO SEE A WIDER AND BETTER WORLD THROUGH THEM.

材质示意: 立体拼贴

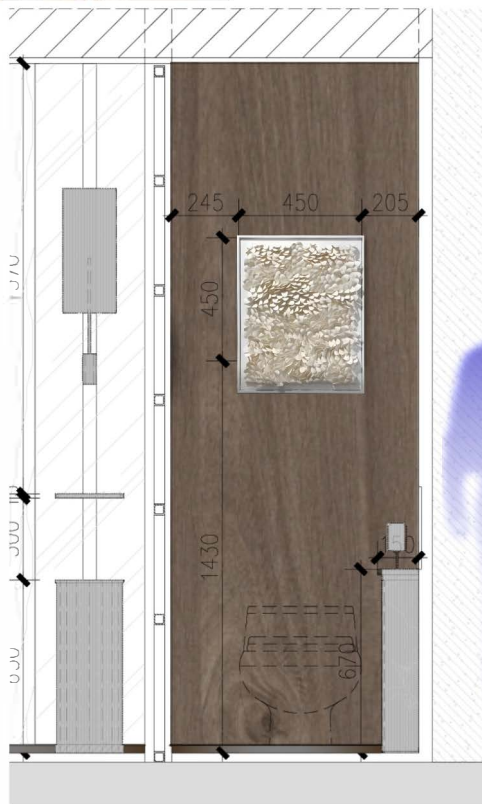

挂画悬挂居中马桶

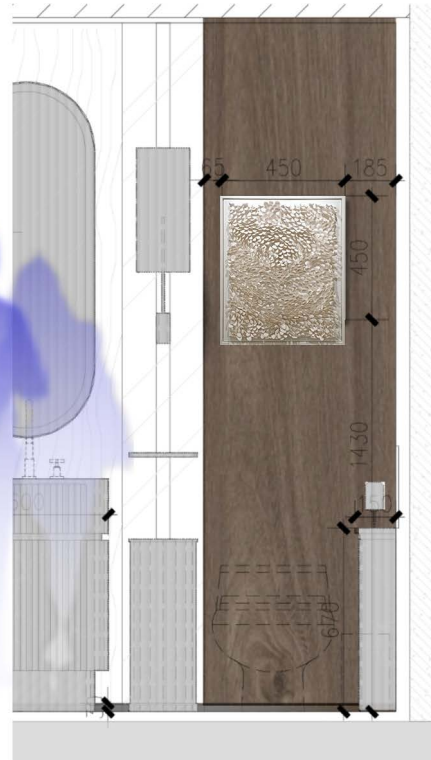

挂画悬挂居中马桶

Furnishing articles and sculpture process requirements

摆件及雕塑工艺要求

1、 Art as the main theme, style, the main form of expression, need to have a strong visual impact

艺术品作为主题思想、风格的主要表现形式，需要具有很强的视觉冲击力。

2、 First, the designer confirmed the design, selected processing materials.

首先草图，效果图由设计师确认，选定加工材料。

3、 According to the site, to determine the size of the sculpture. 根据现场，图纸确定雕塑、摆件大小尺寸。

4、 Make mud draft, foam model, confirm the overall effect. 制作泥稿、泡沫模型，确认整体效果。

5、 Indoor metal art material thickness shall not be less than 1.5 mm, resin thickness shall not be less than 3mm.

金属艺术品材料壁厚室内不得低于1.5mm,树脂壁厚度不得低于3mm。

6、 Resin artwork surface color guarantee does not fade. 树脂艺术品表面颜色保证不褪色。

7、 Seamless metal joints, bending polished smooth. 金属接缝处无缝隙，折弯处打磨光滑。

8、 摆件雕塑必须牢固、稳定、安全、与灯光很好结合。

9、 石材基座必须做好加重加固，以防碰撞引起倒掉。

10、 落地安放艺术品要稳、安全。

平面图

8人包间



12人包间

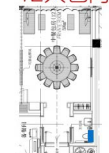

18人包间



休息区

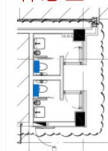

散座区

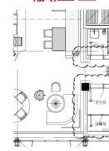

图片仅供参考，以最终效果为准。

Project 项目名称: 杭州天目山格芮精选希尔顿酒店 Serial number 项目编号: 2F-CPR-11

Material 材质: 仿真花艺+陶瓷花器

Process description 工艺说明:

Area 区域: 二层中餐厅走廊

Number 数量: 2组

Size 尺寸: 区域尺寸: W700*H550,W650*H700



花艺尺寸约: W700*H550



花艺尺寸约: W650*H700

花器尺寸约: W400*H400



家具尺寸:W850*H900



注: 1、实际艺术品以中标单位现场核实具体尺寸数量再深化为准;
2、此点位需灯光照亮,需灯光顾问配合处理。

Furnishing articles and sculpture process requirements

摆件及雕塑工艺要求

1、 Art as the main theme, style, the main form of expression, need to have a strong visual impact

艺术品作为主题思想、风格的主要表现形式,需要具有很强的视觉冲击力。

2、 First, the designer confirmed the design, selected processing materials.

首先草图,效果图由设计师确认,选定加工材料。

3、 According to the site, to determine the size of the sculpture. 根据现场,图纸确定雕塑、摆件大小尺寸。

4、 Make mud draft, foam model, confirm the overall effect. 制作泥稿、泡沫模型,确认整体效果。

5、 Indoor metal art material thickness shall not be less than 1.5 mm, resin thickness shall not be less than 3mm.

金属艺术品材料厚度室内不得低于1.5mm,树脂厚度不得低于3mm。

6、 Resin artwork surface color guarantee does not fade. 树脂艺术品表面颜色保证不褪色。

7、 Seamless metal joints, bending polished smooth. 金属接缝处无缝隙,折弯处打磨光滑。

8、 摆件雕塑必须牢固、稳定、安全、与灯光很好结合。

9、 石材基座必须做好加重加固,以防碰撞引起倒掉。

10、落地安放艺术品要稳、安全。

平面图

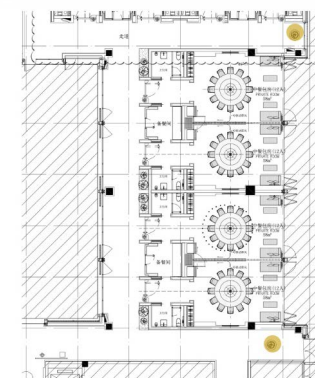

图片仅供参考,以最终效果为准。

Project 项目名称: 杭州天目山格芮精选希尔顿酒店 Serial number 项目编号: 2F-CPR-12

Material 材质: 永生苔藓+仿真树木+仿真绿植+石材+白色沙砾+黑色不锈钢花箱

Process description 工艺说明:

Area 区域: 二层中餐厅走廊

Number 数量: 4组

Size 尺寸: W2500*D800*H2800*1, W2100*D800*H2800*1, W1800*D800*H2800*2



1800



1800



黑色花箱尺寸:
W1800*D800*H800



Furnishing articles and sculpture process requirements

摆件及雕塑工艺要求

- 1、Art as the main theme, style, the main form of expression, need to have a strong visual impact
艺术品作为主题思想、风格的主要表现形式, 需要具有很强的视觉冲击力。
- 2、First, the designer confirmed the design, selected processing materials.
首先草图, 效果图由设计师确认, 选定加工材料。
- 3、According to the site, to determine the size of the sculpture. 根据现场, 图纸确定雕塑、摆件大小尺寸。
- 4、Make mud draft, foam model, confirm the overall effect. 制作泥稿、泡沫模型, 确认整体效果。
- 5、Indoor metal art material thickness shall not be less than 1.5 mm, resin thickness shall not be less than 3mm.
金属艺术品材料壁厚室内不得低于1.5mm, 树脂壁厚不得低于3mm。
- 6、Resin artwork surface color guarantee does not fade. 树脂艺术品表面颜色保证不褪色。
- 7、Seamless metal joints, bending polished smooth. 金属接缝处无缝隙, 折弯处打磨光滑。
- 8、摆件雕塑必须牢固、稳定、安全、与灯光很好结合。
- 9、石材基座必须做好加固, 以防碰撞引起倒掉。
- 10、落地安放艺术品要稳、安全。

平面图

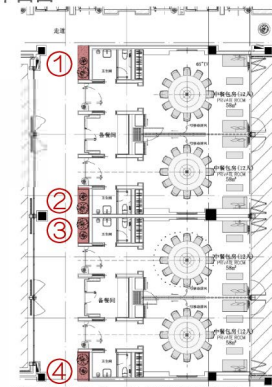

图片仅供参考, 以最终效果为准。

注: 1、实际艺术品以中标单位现场核实具体尺寸数量再深化为准;
2、此点位需灯光照亮, 需灯光顾问配合处理。

Project 项目名称: 杭州天目山格芮精选希尔顿酒店 Serial number 项目编号: 2F-CPR-13

Material 材质: 永生绿植+藤编+木质+陶瓷花器

Process description 工艺说明:

Area 区域: 二层中餐厅休息区

Number 数量: 2件

Size 尺寸: W930*H960,W880*H780

Furnishing articles and sculpture process requirements

摆件及雕塑工艺要求

1、 Art as the main theme, style, the main form of expression, need to have a strong visual impact

艺术品作为主题思想、风格的主要表现形式, 需要具有很强的视觉冲击力。

2、 First, the designer confirmed the design, selected processing materials.

首先草图, 效果图由设计师确认, 选定加工材料。

3、 According to the site, to determine the size of the sculpture. 根据现场, 图纸确定雕塑、摆件大小尺寸。

4、 Make mud draft, foam model, confirm the overall effect. 制作泥稿、泡沫模型, 确认整体效果。

5、 Indoor metal art material thickness shall not be less than 1.5 mm, resin thickness shall not be less than 3mm.

金属艺术品材料壁厚室内不得低于1.5mm,树脂壁厚度不得低于3mm。

6、 Resin artwork surface color guarantee does not fade. 树脂艺术品表面颜色保证不褪色。

7、 Seamless metal joints, bending polished smooth. 金属接缝处无缝隙, 折弯处打磨光滑。

8、 摆件雕塑必须牢固、稳定、安全、与灯光很好结合。

9、 石材基座必须做好加重加固, 以防碰撞引起倒掉。

10、 落地安放艺术品要稳、安全。

平面图

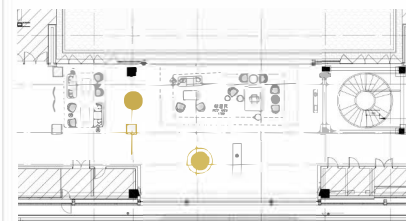

图片仅供参考, 以最终效果为准。



注: 此点位无家具物料书, 此花艺放置摆台上方。

注: 1、实际艺术品以中标单位现场核实具体尺寸数量再深化为准;

Project 项目名称: 杭州天目山格芮精选希尔顿酒店 Serial number 项目编号: 2F-CPR-14

Material 材质: 木质雕刻造型雕塑+黑色石材底座

Process description 工艺说明:

Area 区域: 二层中餐厅走廊

Number 数量: 2组

Size 尺寸: 雕塑: W380*D380*H600, 底座: W450*D450*H850

材质细节: 木纹雕刻

灵感来源: 铁木树杆

此雕塑做左侧同款材质及颜色

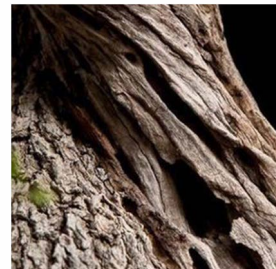

Furnishing articles and sculpture process requirements

摆件及雕塑工艺要求

1、 Art as the main theme, style, the main form of expression, need to have a strong visual impact

艺术品作为主题思想、风格的主要表现形式, 需要具有很强的视觉冲击力。

2、 First, the designer confirmed the design, selected processing materials.

首先草图, 效果图由设计师确认, 选定加工材料。

3、 According to the site, to determine the size of the sculpture. 根据现场, 图纸确定雕塑、摆件大小尺寸。

4、 Make mud draft, foam model, confirm the overall effect. 制作泥稿、泡沫模型, 确认整体效果。

5、 Indoor metal art material thickness shall not be less than 1.5 mm, resin thickness shall not be less than 3mm.

金属艺术品材料厚度室内不得低于1.5mm, 树脂厚度不得低于3mm。

6、 Resin artwork surface color guarantee does not fade. 树脂艺术品表面颜色保证不褪色。

7、 Seamless metal joints, bending polished smooth. 金属接缝处无缝隙, 折弯处打磨光滑。

8、 摆件雕塑必须牢固、稳定、安全、与灯光很好结合。

9、 石材底座必须做好加重加固, 以防碰撞引起倒掉。

10、 落地安放艺术品要稳、安全。

平面图



图片仅供参考, 以最终效果为准。

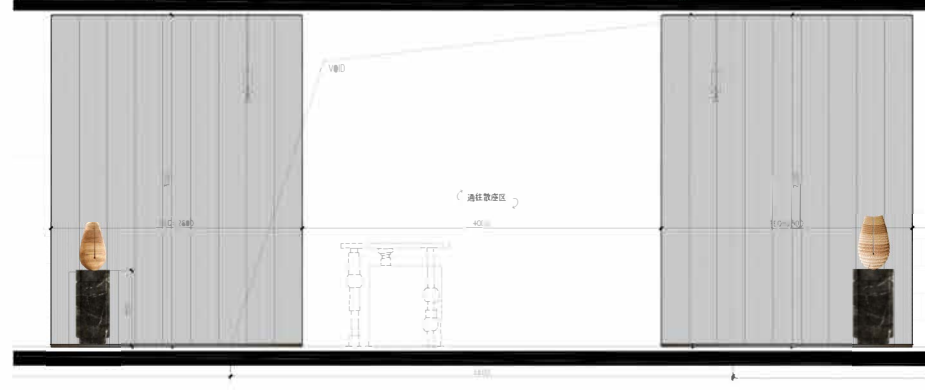

注: 1、实际艺术品以中标单位现场核实具体尺寸数量再深化为准; 2、此点位需灯光照亮, 需灯光顾问配合处理。

Project 项目名称: 杭州天目山格芮精选希尔顿酒店 Serial number 项目编号: 2F-CPR-15

Material 材质: 仿真花艺+陶瓷花器

Process description 工艺说明:

Area 区域: 二层中餐厅电梯厅

Number 数量: 1件

Size 尺寸: W1150*H1050

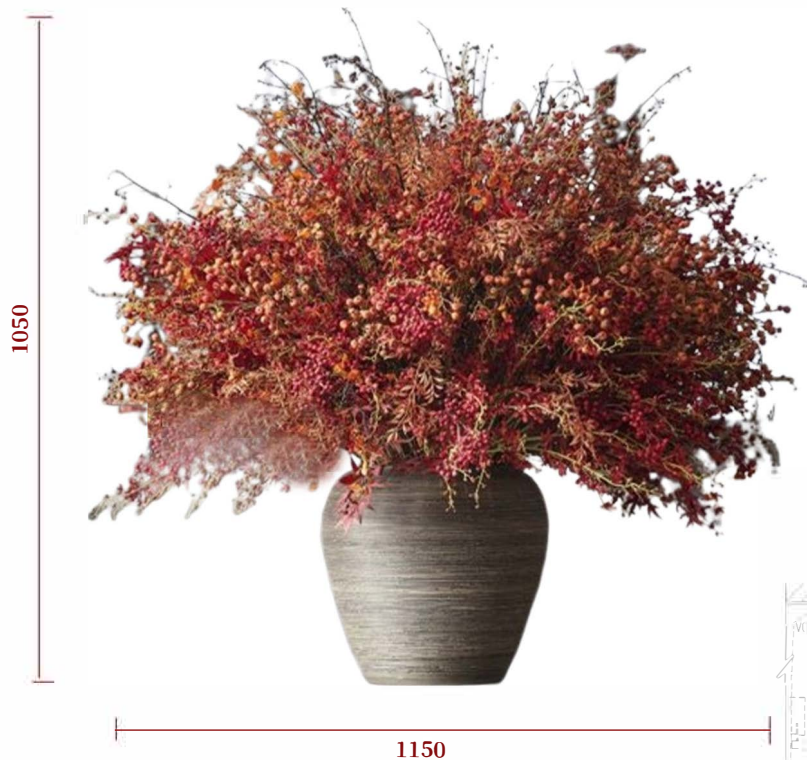

Furnishing articles and sculpture process requirements

摆件及雕塑工艺要求

1、 Art as the main theme, style, the main form of expression, need to have a strong visual impact

艺术品作为主题思想、风格的主要表现形式, 需要具有很强的视觉冲击力。

2、 First, the designer confirmed the design, selected processing materials.

首先草图, 效果图由设计师确认, 选定加工材料。

3、 According to the site, to determine the size of the sculpture. 根据现场, 图纸确定雕塑、摆件大小尺寸。

4、 Make mud draft, foam model, confirm the overall effect. 制作泥稿、泡沫模型, 确认整体效果。

5、 Indoor metal art material thickness shall not be less than 1.5 mm, resin thickness shall not be less than 3mm.

金属艺术品材料壁厚室内不得低于1.5mm,树脂壁厚不得低于3mm。

6、 Resin artwork surface color guarantee does not fade. 树脂艺术品表面颜色保证不褪色。

7、 Seamless metal joints, bending polished smooth. 金属接缝处无缝隙, 折弯处打磨光滑。

8、 摆件雕塑必须牢固、稳定、安全、与灯光很好结合。

9、 石材基座必须做好加重加固, 以防碰撞引起倒塌。

10、 落地安放艺术品要稳、安全。

平面图

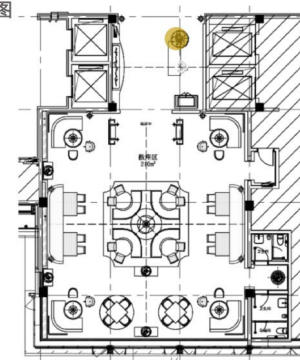

图片仅供参考, 以最终效果为准。

注: 1、实际艺术品以中标单位现场核实具体尺寸数量再深化为准;
2、此点位需灯光照亮, 需灯光顾问配合处理;

同建筑墙面材质

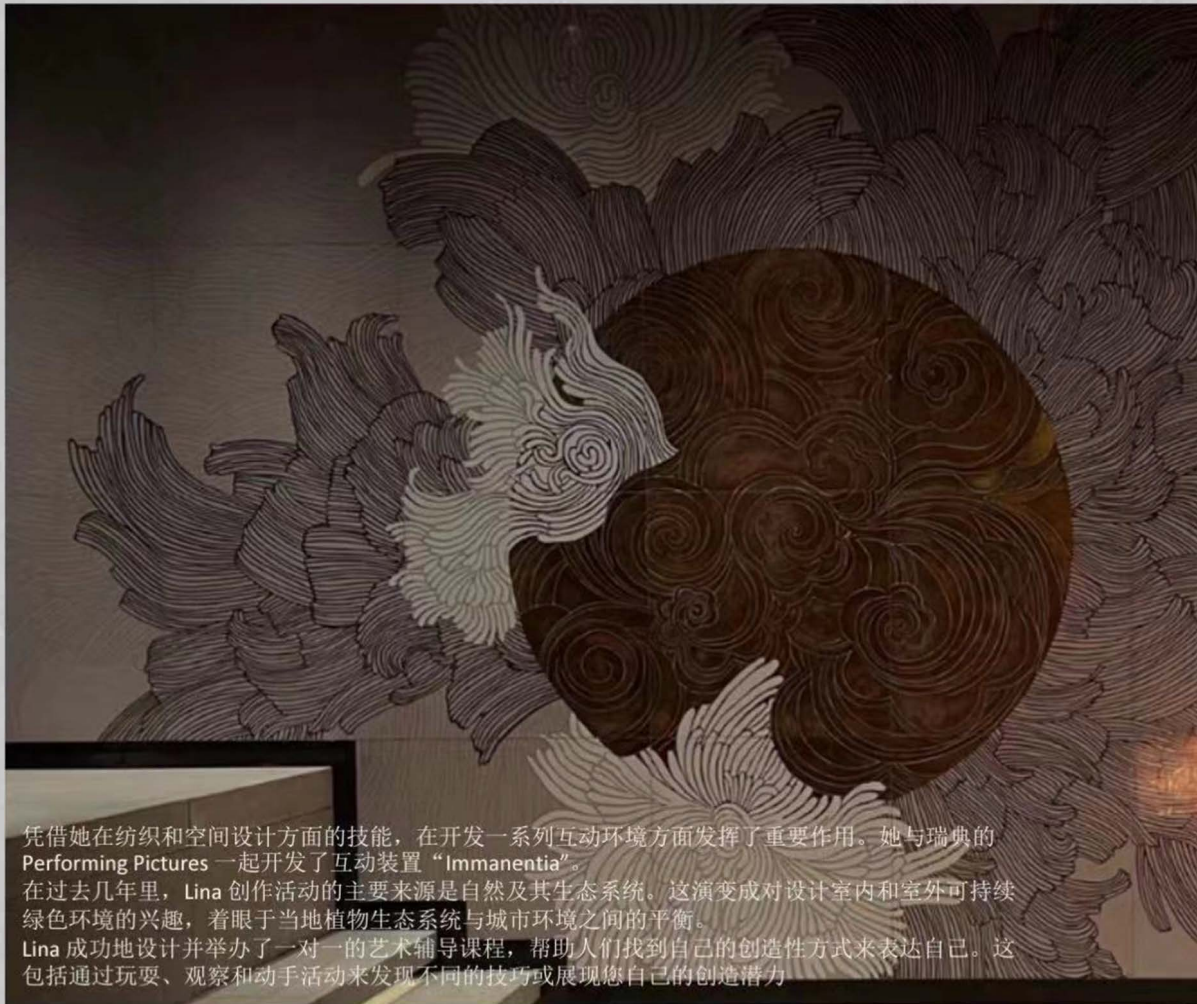

凭借她在纺织和空间设计方面的技能，在开发一系列互动环境方面发挥了重要作用。她与瑞典的 Performing Pictures 一起开发了互动装置“Immanentia”。
在过去几年里，Lina 创作活动的主要来源是自然及其生态系统。这演变成对设计室内和室外可持续绿色环境的兴趣，着眼于当地植物生态系统与城市环境之间的平衡。
Lina 成功地设计并举办了一对一的艺术辅导课程，帮助人们找到自己的创造性方式来表达自己。这包括通过玩耍、观察和动手活动来发现不同的技巧或展现您自己的创造潜力

Lina has been instrumental in developing a range of interactive environments using her skills in textile and spatial design. Together with Performing Pictures in Sweden she developed the interactive installation 'Immanentia'.
Over the last few years, the main source of Lina's creative activity has been nature and its ecosystems. This has evolved into an interest in designing sustainable green environments, both indoors and outdoors, with a focus on the balance between local plant ecosystems and the urban environment.
Lina has successfully designed and conducted one-on-one art coaching sessions to help people find their own creative ways to express themselves. This includes discovering different techniques or revealing your own creative potential through play, observation and hands-on activities. Lina

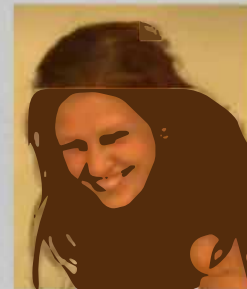

Lina Kusaite
(Belgium)



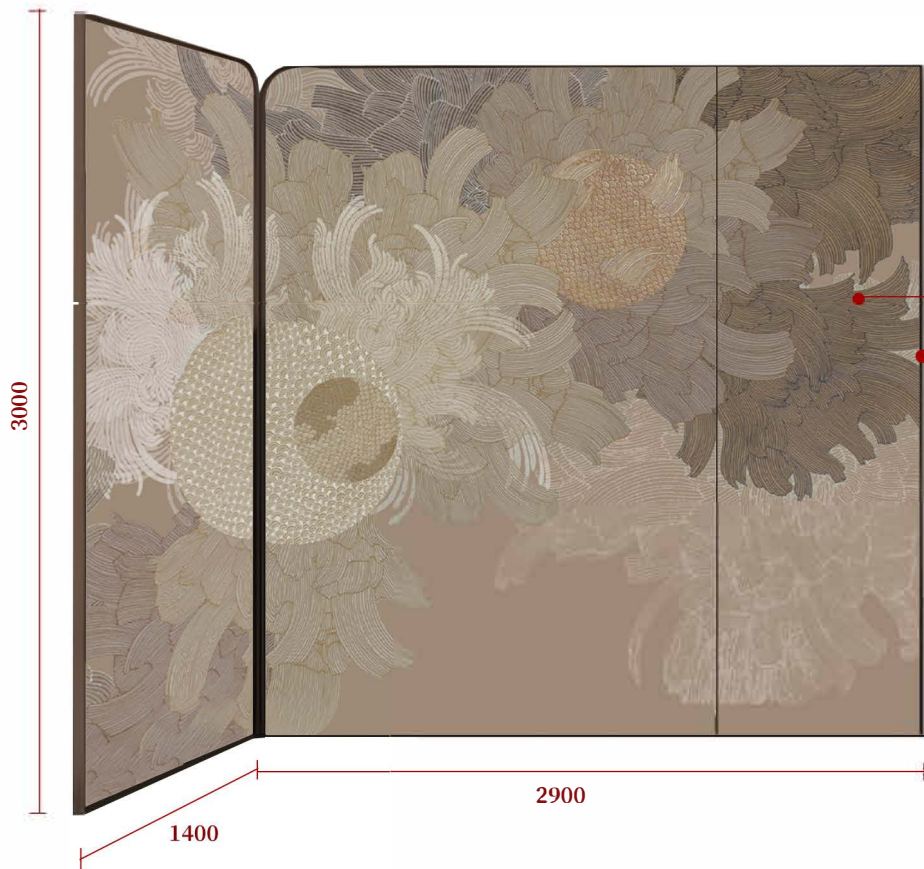

材质细节: 图案凸起肌理



暗纹效果参考



灵感来源: 花瓣

古铜色金属边框



屏风底部做支撑结构与地面打螺栓固定:

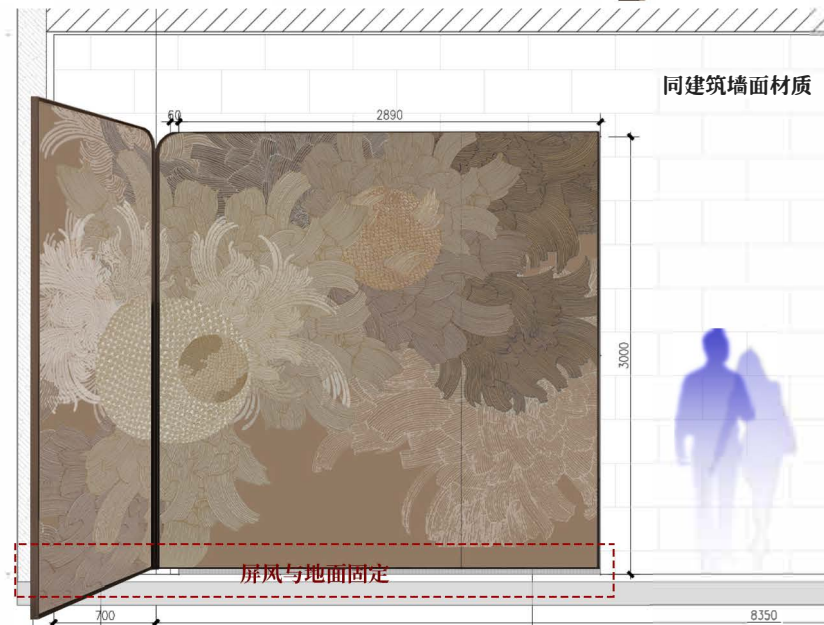

同建筑墙面材质

屏风与地面固定

通过细腻、丰富多变的线条表现出各种花朵迷人的姿态, 给人以独特的、美的享受。宛如一场绚烂的自然盛宴, 每一篇花瓣翩翩起舞, 与雕塑相呼应。

THE CHARMING POSTURES OF VARIOUS FLOWERS ARE EXPRESSED THROUGH DELICATE, RICH AND VARIED LINES, GIVING PEOPLE A UNIQUE AND BEAUTIFUL ENJOYMENT. , LIKE A GORGEOUS NATURAL FEAST, EACH PETAL DANCES GRACEFULLY AND ECHOES THE SCULPTURE.

- 注: 1、实际艺术品以中标单位现场核实具体尺寸数量再深化为准;
2、此点位需灯光照亮, 需灯光顾问配合处理;
3、地面需做预埋加固, 中标单位需深化加固结构。

Furnishing articles and sculpture process requirements

摆件及雕塑工艺要求

- 1、Art as the main theme, style, the main form of expression, need to have a strong visual impact
艺术品作为主题思想、风格的主要表现形式, 需要具有很强的视觉冲击力。
- 2、First, the designer confirmed the design, selected processing materials.
首先草图, 效果图由设计师确认, 选定加工材料。
- 3、According to the site, to determine the size of the sculpture. 根据现场, 图纸确定雕塑、摆件大小尺寸。
- 4、Make mud draft, foam model, confirm the overall effect. 制作泥稿、泡沫模型, 确认整体效果。
- 5、Indoor metal art material thickness shall not be less than 1.5 mm, resin thickness shall not be less than 3mm.
金属艺术品材料厚度室内不得低于1.5mm, 树脂厚度不得低于3mm。
- 6、Resin artwork surface color guarantee does not fade. 树脂艺术品表面颜色保证不褪色。
- 7、Seamless metal joints, bending polished smooth. 金属接缝处无缝隙, 折弯处打磨光滑。
- 8、摆件雕塑必须牢固、稳定、安全、与灯光很好结合。
- 9、石材基座必须做好加固, 以防碰撞引起倒塌。
- 10、落地安放艺术品要稳、安全。

平面图

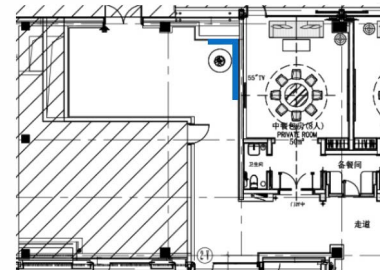

图片仅供参考, 以最终效果为准。

Project 项目名称: 杭州天目山格芮精选希尔顿酒店 Serial number 项目编号: 2F-CPR-17

Material 材质: 永生仿真花艺+金属花器

Process description 工艺说明:

Area 区域: 二层中餐厅走廊

Number 数量: 1件

Size 尺寸: 花艺: W1200*H860,花器: W260*H300

Furnishing articles and sculpture process requirements

摆件及雕塑工艺要求

- 1、Art as the main theme, style, the main form of expression, need to have a strong visual impact
艺术品作为主题思想、风格的主要表现形式, 需要具有很强的视觉冲击力。
- 2、First, the designer confirmed the design, selected processing materials.
首先草图, 效果图由设计师确认, 选定加工材料。
- 3、According to the site, to determine the size of the sculpture. 根据现场, 图纸确定雕塑、摆件大小尺寸。
- 4、Make mud draft, foam model, confirm the overall effect. 制作泥稿、泡沫模型, 确认整体效果。
- 5、Indoor metal art material thickness shall not be less than 1.5 mm, resin thickness shall not be less than 3mm.
金属艺术品材料厚度室内不得低于1.5mm,树脂厚度不得低于3mm。
- 6、Resin artwork surface color guarantee does not fade, 树脂艺术品表面颜色保证不褪色。
- 7、Seamless metal joints, bending polished smooth. 金属接缝处无缝隙, 折弯处打磨光滑。
- 8、摆件雕塑必须牢固、稳定、安全、与灯光很好结合。
- 9、石材基座必须做好加重加固, 以防碰撞引起倒塌。
- 10、落地安放艺术品要稳、安全。

平面图

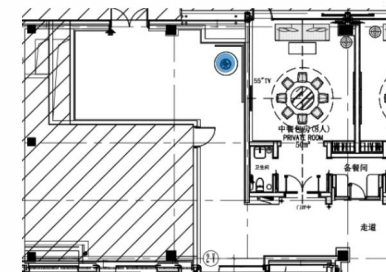

图片仅供参考, 以最终效果为准。



花器尺寸约: W260*H300

通过细腻、丰富多变的线条表现出各种花朵迷人的姿态, 给人以独特的、美的享受。宛如一场绚烂的自然盛宴, 每一篇花瓣翩翩起舞, 与雕塑相呼应。

THE CHARMING POSTURES OF VARIOUS FLOWERS ARE EXPRESSED THROUGH DELICATE, RICH AND VARIED LINES, GIVING PEOPLE A UNIQUE AND BEAUTIFUL ENJOYMENT. , LIKE A GORGEOUS NATURAL FEAST, EACH PETAL DANCES GRACEFULLY AND ECHOS THE SCULPTURE.

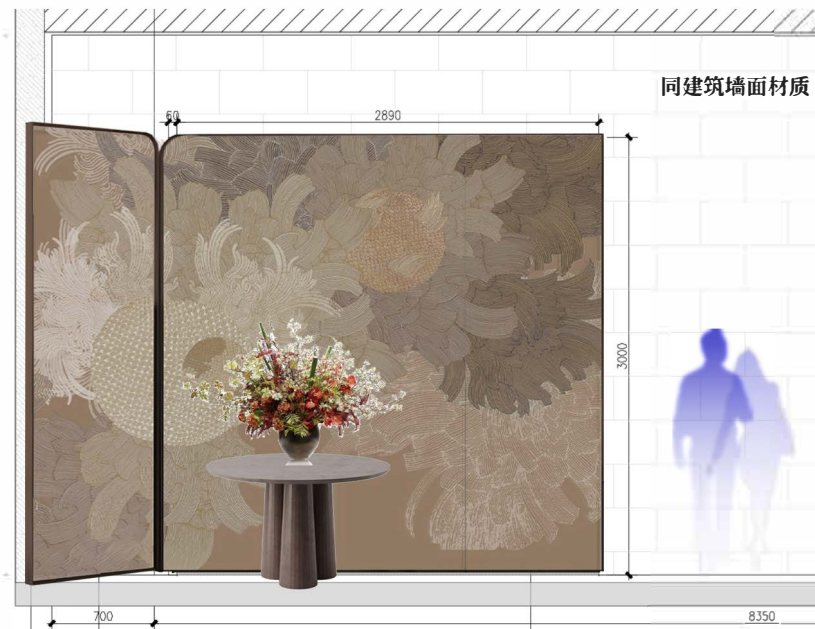

家具尺寸:W850*H900

注: 1、实际艺术品以中标单位现场核实具体尺寸数量再深化为准;
2、此点位需灯光照亮, 需灯光顾问配合处理;

Project 项目名称: 杭州天目山格芮精选希尔顿酒店 Serial number 项目编号: 2F-CPR-18

Material 材质: 永生苔藓+金属花器

Process description 工艺说明:

Area 区域: 二层中餐厅休息区

Number 数量: 1件

Size 尺寸: W550*D550*H150

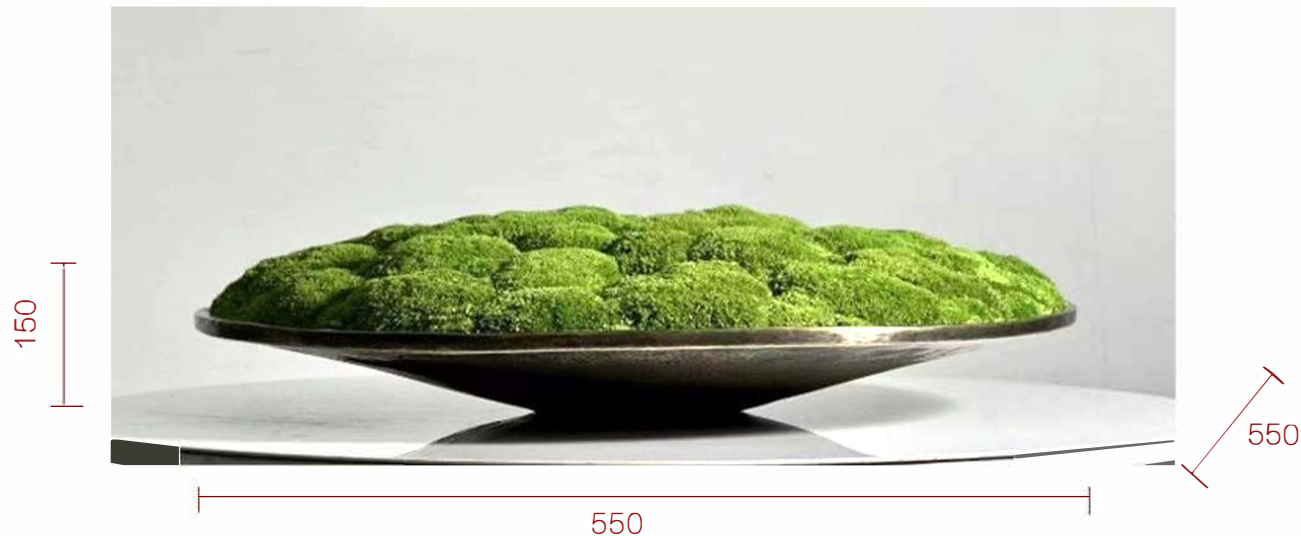

深胡桃木见 WD-2003

(上方摆放艺术品)

面料见 F-2038.1

面料见 F-2038.1

深胡桃木见 WD-2003
尼龍腳墊

Furnishing articles and sculpture process requirements

摆件及雕塑工艺要求

1、 Art as the main theme, style, the main form of expression, need to have a strong visual impact

艺术品作为主题思想、风格的主要表现形式, 需要具有很强的视觉冲击力。

2、 First, the designer confirmed the design, selected processing materials.

首先草图, 效果图由设计师确认, 选定加工材料。

3、 According to the site, to determine the size of the sculpture. 根据现场, 图纸确定雕塑、摆件大小尺寸。

4、 Make mud draft, foam model, confirm the overall effect. 制作泥稿、泡沫模型, 确认整体效果。

5、 Indoor metal art material thickness shall not be less than 1.5 mm, resin thickness shall not be less than 3mm.

金属艺术品材料壁厚室内不得低于1.5mm,树脂壁厚不得低于3mm。

6、 Resin artwork surface color guarantee does not fade. 树脂艺术品表面颜色保证不褪色。

7、 Seamless metal joints, bending polished smooth. 金属接缝处无缝隙, 折弯处打磨光滑。

8、 摆件雕塑必须牢固、稳定、安全、与灯光很好结合。

9、 石材基座必须做好加重加固, 以防碰撞引起倒掉。

10、 落地安放艺术品要稳、安全。

平面图

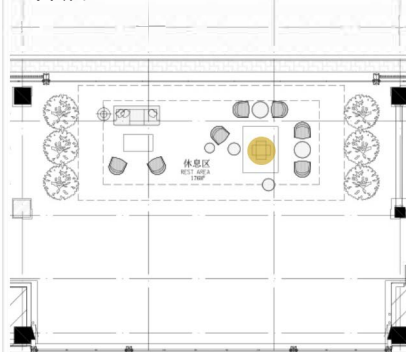

图片仅供参考, 以最终效果为准。

注: 1、实际艺术品以中标单位现场核实现体尺寸数量再深化为准;

Project 项目名称: 杭州天目山格芮精选希尔顿酒店 Serial number 项目编号: 2F-CPR-18
Area 区域: 二层中餐厅餐桌 Number

Material 材质: 木质摆件+绿植苔藓+圆形木质托盘

Process description 工艺说明:

Size 尺寸: W1000*H250

Furnishing articles and sculpture process requirements

摆件及雕塑工艺要求

1、 Art as the main theme, style, the main form of expression, need to have a strong visual impact

艺术品作为主题思想、风格的主要表现形式, 需要具有很强的视觉冲击力。

2、 First, the designer confirmed the design, selected processing materials.

首先草图, 效果图由设计师确认, 选定加工材料。

3、 According to the site, to determine the size of the sculpture. 根据现场, 图纸确定雕塑、摆件大小尺寸。

4、 Make mud draft, foam model, confirm the overall effect. 制作泥稿、泡沫模型, 确认整体效果。

5、 Indoor metal art material thickness shall not be less than 1.5 mm, resin thickness shall not be less than 3mm.

金属艺术品材料壁厚室内不得低于1.5mm, 树脂壁厚不得低于3mm。

6、 Resin artwork surface color guarantee does not fade. 树脂艺术品表面颜色保证不褪色。

7、 Seamless metal joints, bending polished smooth. 金属接缝处无缝隙, 折弯处打磨光滑。

8、 摆件雕塑必须牢固、稳定、安全、与灯光很好结合。

9、 石材基座必须做好加重加固, 以防碰撞引起倒掉。

10、 落地安放艺术品要稳、安全。



平面图



注: 1、实际艺术品以中标单位现场核实具体尺寸数量再深化为准;

图片仅供参考, 以最终效果为准。

数量: 5件



5

五层会客厅

FIFTH FLOOR RECEPTION ROOM

[涓涓细流]

trickling water

五层总平面

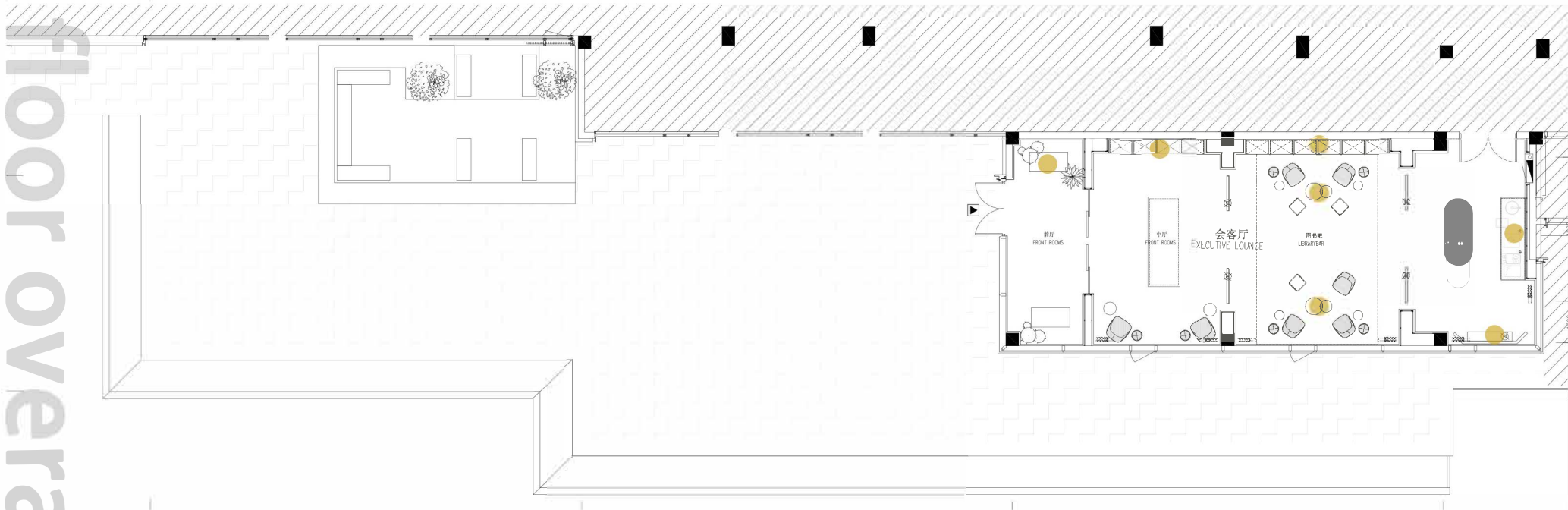

- 雕塑 ☆ A级 ●
- 挂画 — B级 ●
- 摆件 ○ C级 ●

注：所有艺术品点位位置需要灯光配合



五层会客厅意向图

INTENTIONAL DRAWING OF THE FIFTH FLOOR RECEPTION ROOM

FIFTH FLOOR RECEPTION ROOM



他们在诗中说，“尔从山中来，早晚发天目。”
说，“天目之山，茗水出焉，龙飞凤舞，萃于临安。”
他们说，“自有天地有此溪，泓渟百折净无泥。”

THEY SAID IN THE POEM, "YOU COME FROM THE MOUNTAINS, AND SOONER OR LATER YOU WILL HAVE YOUR THIRD EYE."
SAID, "ON THE MOUNTAIN OF TIANMU, THE SWEET WATER FLOWS OUT, AND DRAGONS AND PHOENIXES DANCE, GATHERING IN LIN'AN."
THEY SAID, "THERE IS SUCH A STREAM IN HEAVEN AND EARTH, AND IT IS PURE AND CLEAR OF MUD."

迎客瀑,从山上倾泻而下,薄薄的雾,飘在四周,给人以一股神秘感。瀑布如同一条银色的闪闪发光的长丝带,正如李白说的“飞流直下三千尺,疑是银河落九天”的感觉简直一模一样。

YINGKE WATERFALL POURS DOWN FROM THE MOUNTAIN, AND THIN MIST FLOATS AROUND, GIVING PEOPLE A SENSE OF MYSTERY. THE WATERFALL IS LIKE A LONG SILVER SHIMMERING RIBBON, JUST LIKE WHAT LI BAI SAID: "FLYING DOWN THREE THOUSAND FEET, IT IS LIKE THE MILKY WAY FALLING FROM THE SKY." THE FEELING IS EXACTLY THE SAME.

Project 项目名称: 杭州天目山格芮精选希尔顿酒店 Serial number 项目编号: 5F-EL-01

Material 材质: 陶瓷,玻璃,烛台, 金属,石材,真书书籍

Process description 工艺说明:

Area 区域: 五层会客厅

Number 数量: 1组

Size 尺寸: 详见清单

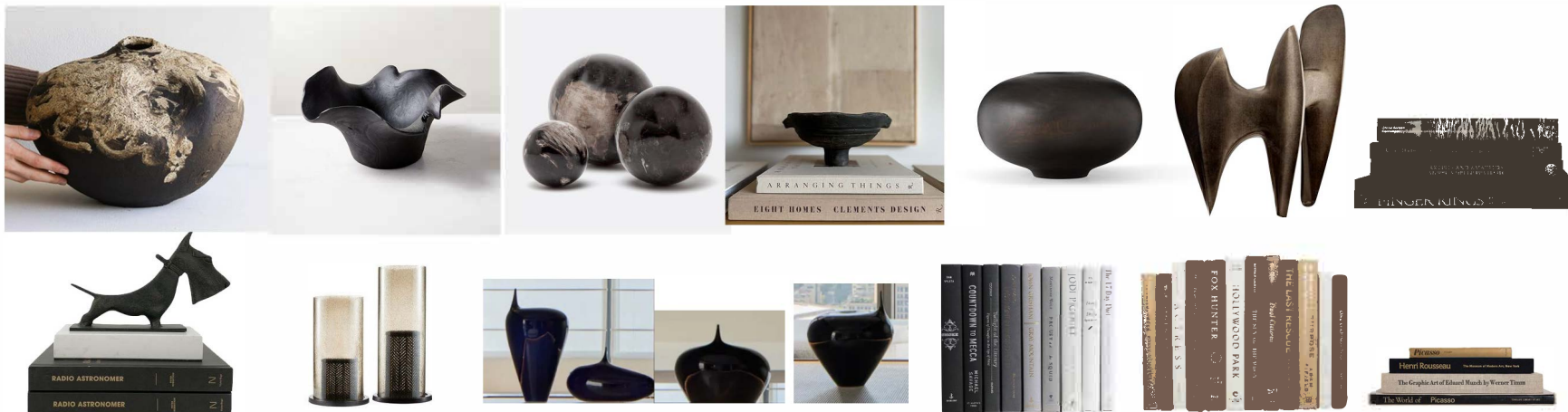

Furnishing articles and sculpture process requirements

摆件及雕塑工艺要求

1、 Art as the main theme, style, the main form of expression, need to have a strong visual impact

艺术品作为主题思想、风格的主要表现形式,需要具有很强的视觉冲击力。

2、 First, the designer confirmed the design, selected processing materials.

首先草图,效果图由设计师确认,选定加工材料。

3、 According to the site, to determine the size of the sculpture. 根据现场,图纸确定雕塑、摆件大小尺寸。

4、 Make mud draft, foam model, confirm the overall effect. 制作泥稿、泡沫模型,确认整体效果。

5、 Indoor metal art material thickness shall not be less than 1.5 mm, resin thickness shall not be less than 3mm.

金属艺术品材料壁厚室内不得低于1.5mm,树脂壁厚度不得低于3mm。

6、 Resin artwork surface color guarantee does not fade. 树脂艺术品表面颜色保证不褪色。

7、 Seamless metal joints, bending polished smooth. 金属接缝处无缝隙,折弯处打磨光滑。

8、 摆件雕塑必须牢固、稳定、安全、与灯光很好结合。

9、 石材基座必须做好加重加固,以防碰撞引起倒掉。

10、落地安放艺术品要稳、安全。

平面图

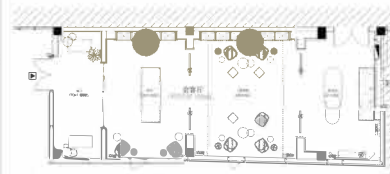

立面

图片仅供参考,以最终效果为准。

注: 1、实际艺术品以中标单位现场核实具体尺寸数量再深化为准;
2、此点位需灯光照亮,需灯光顾问配合处理。

Project 项目名称: 杭州天目山格芮精选希尔顿酒店 Serial number 项目编号: 5F-EL-02

Material 材质: 陶瓷,金属,纸质,高仿真花艺,高仿真青苔

Process description 工艺说明:

Area 区域: 五层会客厅

Number 数量: 1组

Size 尺寸: 大开书籍W420*D297*H25, W370*D260*H20, 金属花器+青苔W240*H28, 陶瓷花器+花艺W300*D300*H480

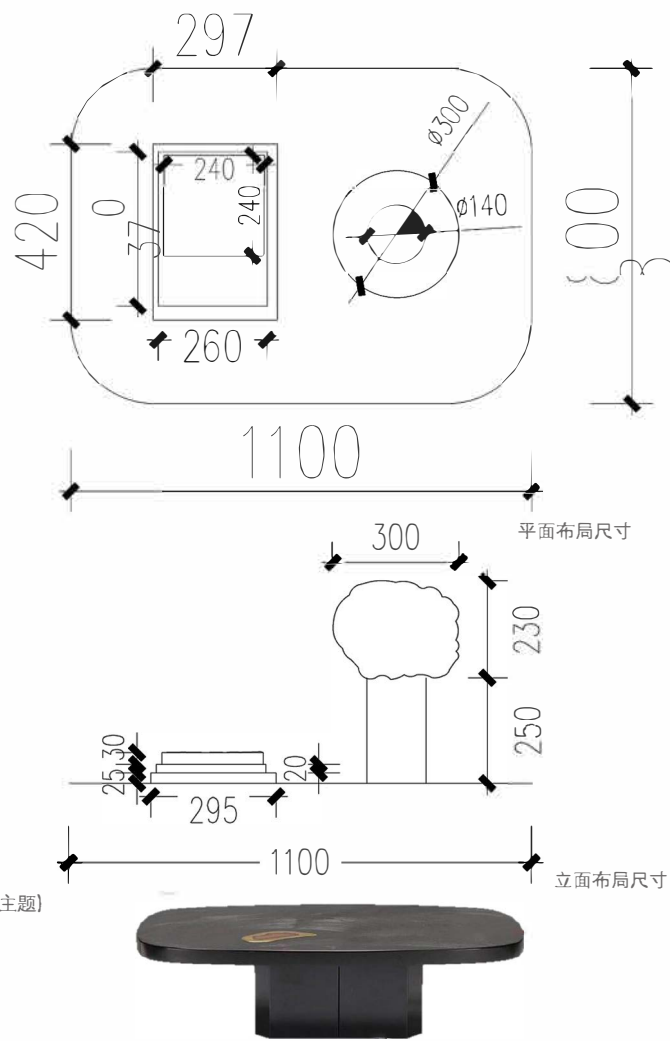

Furnishing articles and sculpture process requirements

摆件及雕塑工艺要求

- 1、Art as the main theme, style, the main form of expression, need to have a strong visual impact
艺术品作为主题思想、风格的主要表现形式, 需要具有很强的视觉冲击力。
- 2、First, the designer confirmed the design, selected processing materials.
首先草图, 效果图由设计师确认, 选定加工材料。
- 3、According to the site, to determine the size of the sculpture.
根据现场, 图纸确定雕塑、摆件大小尺寸。
- 4、Make mud draft, foam model, confirm the overall effect.
制作泥稿、泡沫模型, 确认整体效果。
- 5、Indoor metal art material thickness shall not be less than 1.5 mm, resin thickness shall not be less than 3mm.
金属艺术品材料厚度室内不得低于1.5mm,树脂壁厚度不得低于3mm。
树脂艺术品表面颜色保证不褪色。
- 6、Resin artwork surface color guarantee does not fade.
树脂艺术品表面颜色保证不褪色。
- 7、Seamless metal joints, bending polished smooth.
金属接缝处无缝隙, 折弯处打磨光滑。
- 8、摆件雕塑必须牢固、稳定、安全、与灯光很好结合。
- 9、石材基座必须做好加重加固, 以防碰撞引起倒掉。
- 10、落地安放艺术品要稳、安全。

平面图

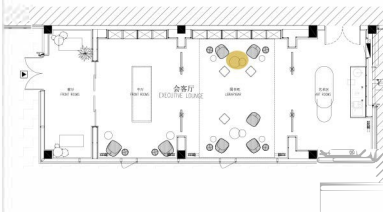

图片仅供参考, 以最终效果为准。

注: 1、实际艺术品以中标单位现场核实具体尺寸数量再深化为准;
2、此点位需灯光照亮, 需灯光顾问配合处理。

Project 项目名称: 杭州天目山格芮精选希尔顿酒店 Serial number 项目编号: 5F-EL-03

Material 材质: 陶瓷,金属,塑料,纸质,高仿真青苔

Process description 工艺说明:

Area 区域: 五层会客厅

Number 数量: 1组

Size 尺寸: 大开书籍W420*D297*H25,电子烛台D150*H200,金属摆件W210*D150*H40,陶瓷花器+青苔D240*H90,陶瓷花器D240*H45

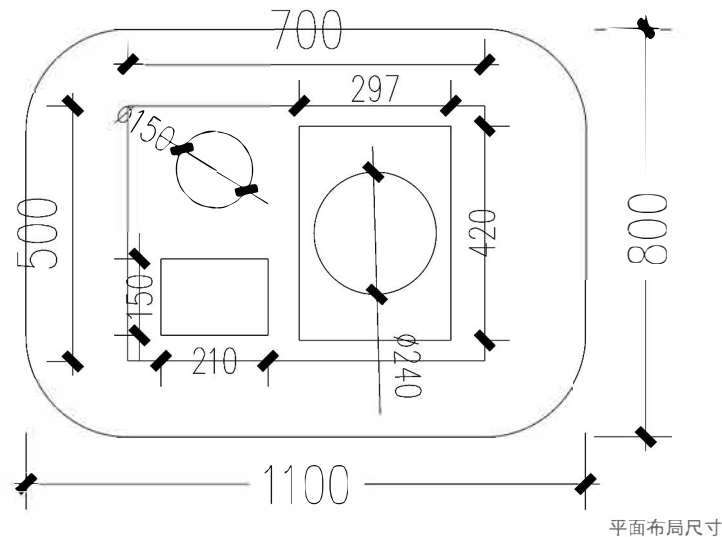
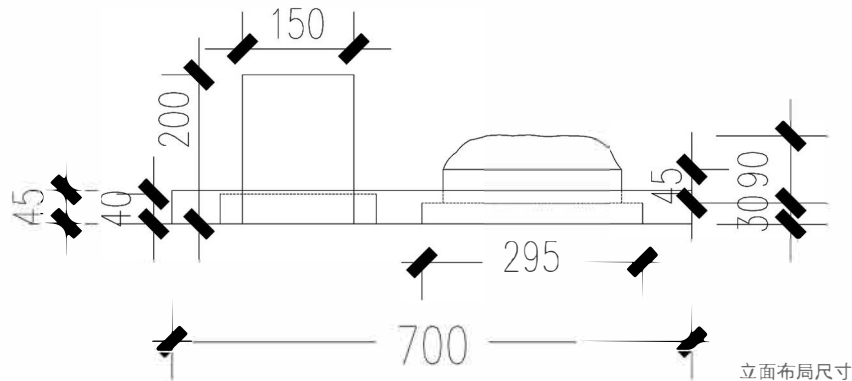

Furnishing articles and sculpture process requirements

摆件及雕塑工艺要求

1、Art as the main theme, style, the main form of expression, need to have a strong visual impact

艺术品作为主题思想、风格的主要表现形式,需要具有很强的视觉冲击力。

2、First, the designer confirmed the design, selected processing materials.

首先草图,效果图由设计师确认,选定加工材料。

3、According to the site, to determine the size of the sculpture. 根据现场,图纸确定雕塑、摆件大小尺寸。

4、Make mud draft, foam model, confirm the overall effect. 制作泥稿、泡沫模型,确认整体效果。

5、Indoor metal art material thickness shall not be less than 1.5 mm, resin thickness shall not be less than 3mm.

金属艺术品材料壁厚室内不得低于1.5mm,树脂壁厚度不得低于3mm。

6、Resin artwork surface color guarantee does not fade. 树脂艺术品表面颜色保证不褪色。

7、Seamless metal joints, bending polished smooth. 金属接缝处无缝隙,折弯处打磨光滑。

8、摆件雕塑必须牢固、稳定、安全、与灯光很好结合。

9、石材基座必须做好加重加固,以防碰撞引起倒掉。

10、落地安放艺术品要稳、安全。

平面图



电子烛台

高仿真青苔

黑色陶瓷花器

金属摆件

大开正版书籍(自然主题)

黑灰色金属托盘



硬装家具尺寸: W1400*D850*H450

图片仅供参考,以最终效果为准。

注: 1、实际艺术品以中标单位现场核实具体尺寸数量再深化为准;
2、此点位需灯光照亮,需灯光顾问配合处理。

Project 项目名称: 杭州天目山格芮精选希尔顿酒店 Serial number 项目编号: 5F-EL-05

Material 材质: 木质+陶瓷+木质装饰盒+仿真蜡烛+烛台+书籍

Process description 工艺说明:

Area 区域: 五层会客厅

Number 数量: 1组

Size 尺寸: 详见清单



Furnishing articles and sculpture process requirements

摆件及雕塑工艺要求

1、 Art as the main theme, style, the main form of expression, need to have a strong visual impact

艺术品作为主题思想、风格的主要表现形式, 需要具有很强的视觉冲击力。

2、 First, the designer confirmed the design, selected processing materials.

首先草图, 效果图由设计师确认, 选定加工材料。

3、 According to the site, to determine the size of the sculpture. 根据现场, 图纸确定雕塑、摆件大小尺寸。

4、 Make mud draft, foam model, confirm the overall effect. 制作泥稿、泡沫模型, 确认整体效果。

5、 Indoor metal art material thickness shall not be less than 1.5 mm, resin thickness shall not be less than 3mm. 金属艺术品材料厚度室内不得低于1.5mm, 树脂厚度不得低于3mm。

6、 Resin artwork surface color guarantee does not fade. 树脂艺术品表面颜色保证不褪色。

7、 Seamless metal joints, bending polished smooth. 金属接缝处无缝隙, 折弯处打磨光滑。

8、 摆件雕塑必须牢固、稳定、安全、与灯光很好结合。

9、 石材基座必须做好加重加固, 以防碰撞引起倒掉。

10、 落地安放艺术品要稳、安全。

平面图

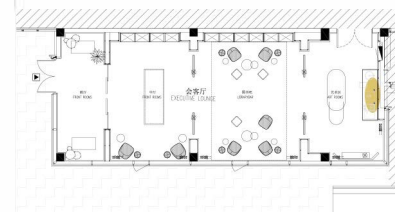

注:

- 1、实际艺术品以中标单位现场核实具体尺寸数量再深化为准;
- 2、此点位需灯光照亮, 需灯光顾问配合处理。

图片仅供参考, 以最终效果为准。

Project 项目名称: 杭州天目山格芮精选希尔顿酒店 Serial number 项目编号: 5F-EL-06

Material 材质: 仿真花艺+陶瓷花器

Process description 工艺说明:

Area 区域: 五层会客厅

Number 数量: 1件

Size 尺寸: W670*H380

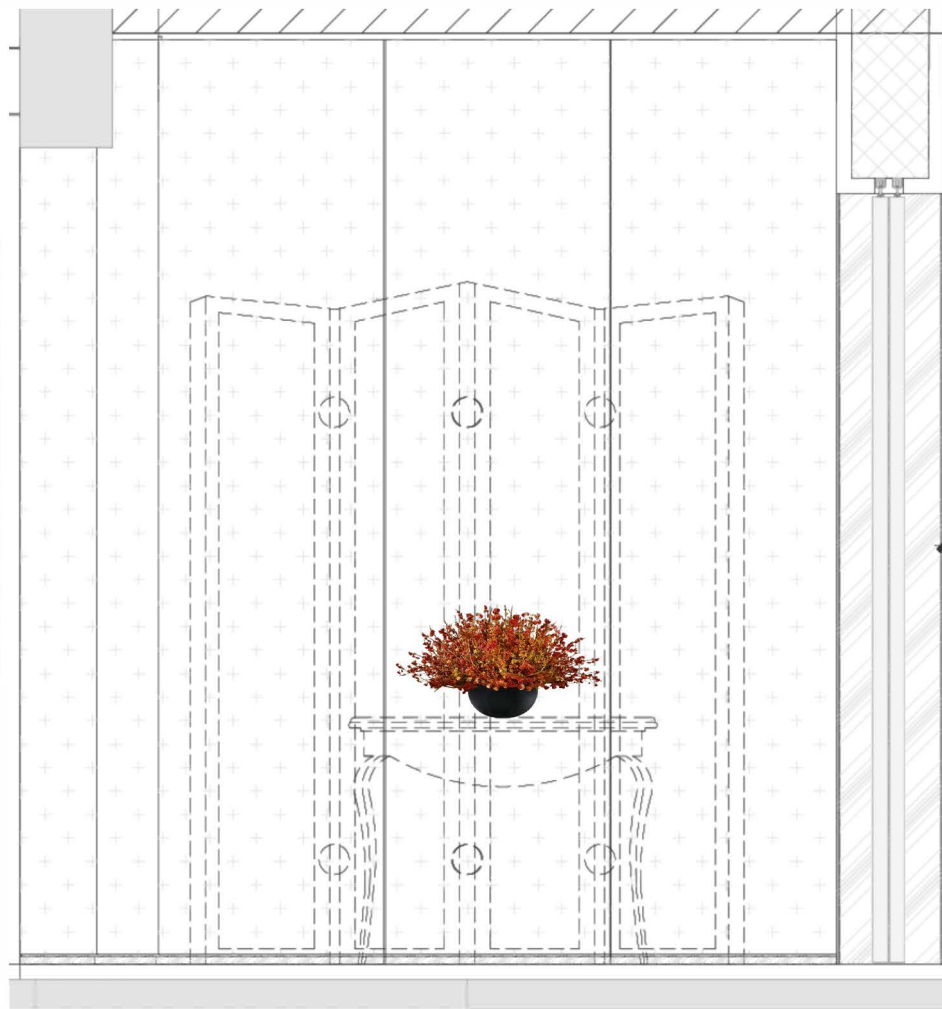
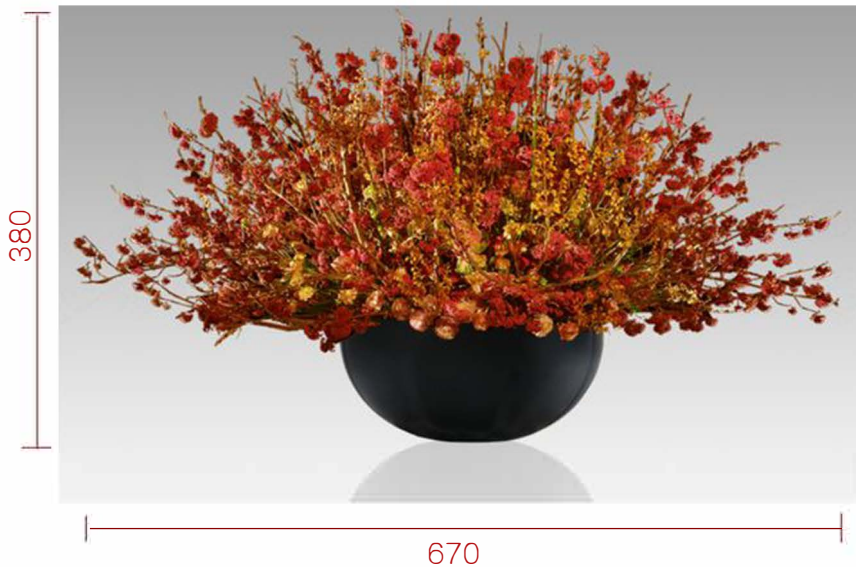

Furnishing articles and sculpture process requirements

摆件及雕塑工艺要求

1、 Art as the main theme, style, the main form of expression, need to have a strong visual impact

艺术品作为主题思想、风格的主要表现形式, 需要具有很强的视觉冲击力。

2、 First, the designer confirmed the design, selected processing materials

首先草图, 效果图由设计师确认, 选定加工材料。

3、 According to the site, to determine the size of the sculpture. 根据现场, 图纸确定雕塑、摆件大小尺寸。

4、 Make mud draft, foam model, confirm the overall effect. 制作泥稿、泡沫模型, 确认整体效果。

5、 Indoor metal art material thickness shall not be less than 1.5 mm, resin thickness shall not be less than 3mm. 金属艺术品材料壁厚室内不得低于1.5mm,树脂壁厚不得低于3mm。

6、 Resin artwork surface color guarantee does not fade. 树脂艺术品表面颜色保证不褪色。

7、 Seamless metal joints, bending polished smooth. 金属接缝处无缝隙, 折弯处打磨光滑。

8、 摆件雕塑必须牢固、稳定、安全、与灯光很好结合。

9、 石材基座必须做好加重加固, 以防碰撞引起倒掉。

10、 落地安放艺术品要稳、安全。

平面图

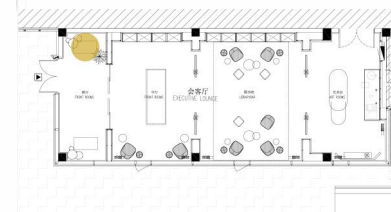

注: 1、实际艺术品以中标单位现场核实具体尺寸数量再深化为准;
2、此点位需灯光照亮, 需灯光顾问配合处理。

图片仅供参考, 以最终效果为准。

Project 项目名称: 杭州天目山格芮精选希尔顿酒店 Serial number 项目编号: 5F-EL-07

Material 材质: 金属丝线+金属框架+石材底座

Process description 工艺说明:

Area 区域: 五层会客厅

Number 数量: 1件

Size 尺寸: 整体: W520*D300*H780。底台W320*D250*H40



天目山间的溪流, 抽象并符号化重新组合生成艺术雕塑表达在空间的流动性。

THE STREAMS IN TIANMU MOUNTAIN ARE ABSTRACTED AND SYMBOLIZED AND REASSEMBLED TO GENERATE ARTISTIC SCULPTURES THAT EXPRESS FLUIDITY IN SPACE.

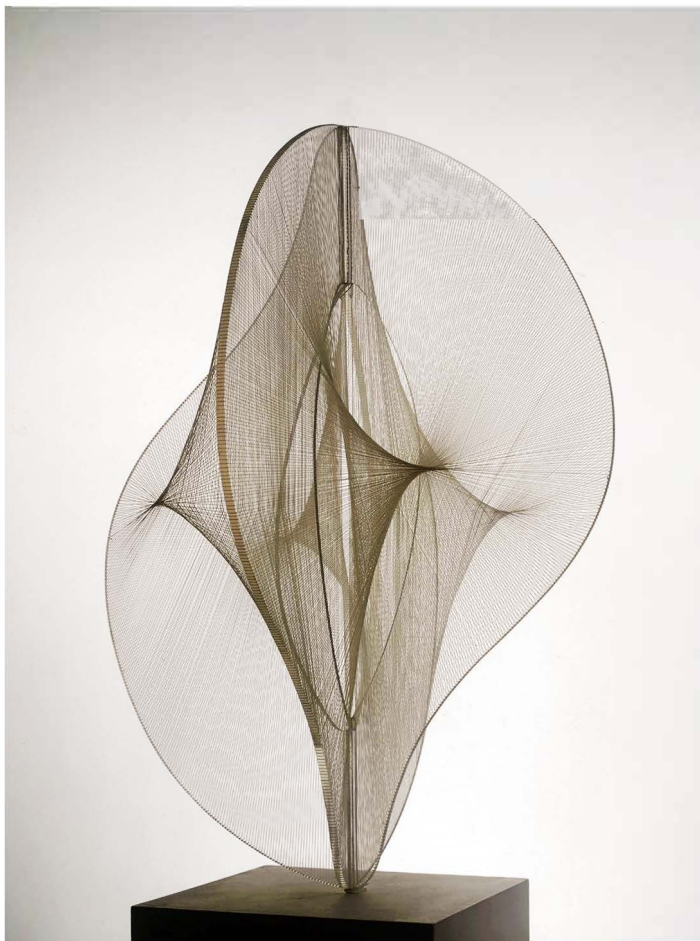

灵感来源



立面尺寸



材质质感

Furnishing articles and sculpture process requirements

摆件及雕塑工艺要求

- 1、Art as the main theme, style, the main form of expression, need to have a strong visual impact
艺术品作为主题思想、风格的主要表现形式, 需要具有很强的视觉冲击力。
- 2、First, the designer confirmed the design, selected processing materials.
首先草图, 效果图由设计师确认, 选定加工材料。
- 3、According to the site, to determine the size of the sculpture. 根据现场, 图纸确定雕塑、摆件大小尺寸。
- 4、Make mud draft, foam model, confirm the overall effect. 制作泥稿、泡沫模型, 确认整体效果。
- 5、Indoor metal art material thickness shall not be less than 1.5 mm, resin thickness shall not be less than 3mm.
金属艺术品材料壁厚室内不得低于1.5mm, 树脂壁厚不得低于3mm。
- 6、Resin artwork surface color guarantee does not fade. 树脂艺术品表面颜色保证不褪色。
- 7、Seamless metal joints, bending polished smooth. 金属接缝处无缝隙, 折弯处打磨光滑。
- 8、摆件雕塑必须牢固、稳定、安全、与灯光很好结合。
- 9、石材基座必须做好加重加固, 以防碰撞引起倒掉。
- 10、落地安放艺术品要稳、安全。

平面图

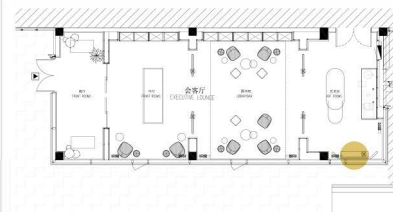

图片仅供参考, 以最终效果为准。

注: 1、实际艺术品以中标单位现场核实具体尺寸数量再深化为准;
2、此点位需灯光照亮, 需灯光顾问配合处理。



一层研学中心

RESEARCH CENTER ON THE FIRST FLOOR

[籽种孕育&岁月年轮]

Seed Breeding & Year Rings

Research Center

研学中心

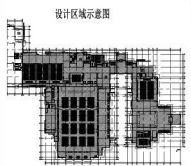

设计区域示意图

防火分区示意图

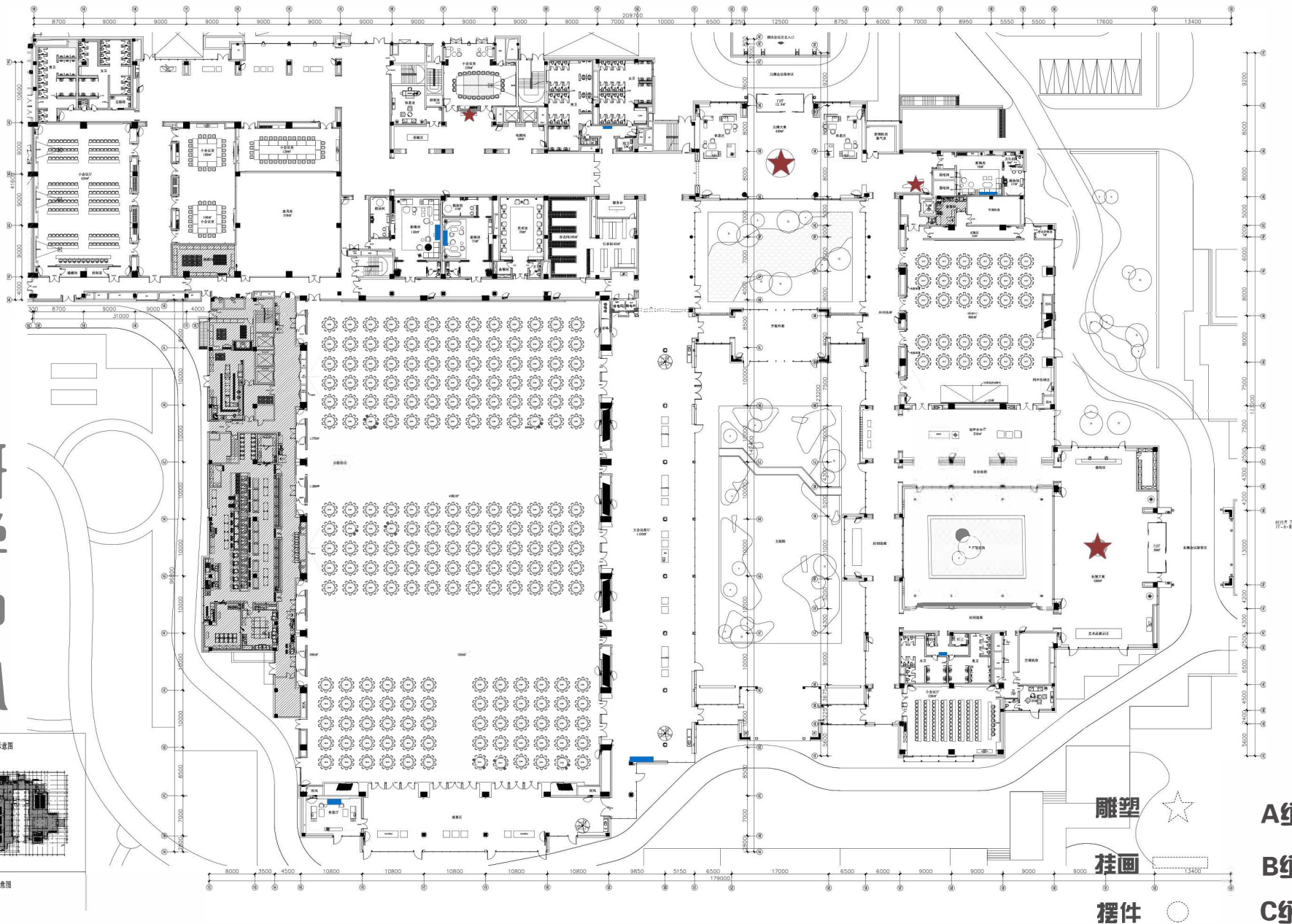

- A级 ●
- B级 ●
- C级 ●

- 雕塑 ☆
- 挂画 □
- 摆件 ○

注：所有艺术品点位位置需要灯光配合



一层研学中心东侧大堂效果图

RENDERING OF THE LOBBY ON THE EAST SIDE OF THE STUDY CENTER ON THE FIRST FLOOR



一层研学中心东侧大堂效果图

RENDERING OF THE LOBBY ON THE EAST SIDE OF THE STUDY CENTER ON THE FIRST FLOOR



一层会展前厅效果图

RENDERING OF THE EXHIBITION HALL ON THE FIRST FLOOR



籽种，犹如大自然遗落的神秘珍宝。它们小巧而精致，蕴含着生命的密码和未来的希望。每一颗籽种都承载着山林的气息，那是一种质朴而纯粹的味道，仿佛凝聚了天目山的天地精华。

SEEDS ARE LIKE MYSTERIOUS TREASURES LEFT BEHIND BY NATURE. THEY ARE SMALL AND DELICATE, CONTAINING THE CODE OF LIFE AND HOPE FOR THE FUTURE. EACH SEED CARRIES THE SCENT OF THE MOUNTAINS AND FORESTS, A SIMPLE AND PURE TASTE THAT SEEMS TO CONDENSE THE ESSENCE OF TIANMU MOUNTAIN.

树木的年轮，是岁月留下的无声诗篇。一圈又一圈，记录着时光的流转和变迁。

它们是天目山成长的见证，也是大自然永恒魅力的体现。那一圈圈的年轮里，藏着阳光雨露的记忆，藏着四季交替的秘密，让人在欣赏之余，不禁对岁月的深邃和神奇心生敬畏与感动。

THE GROWTH RINGS OF TREES ARE THE SILENT POEMS LEFT BY THE YEARS. CIRCLE AFTER CIRCLE, RECORDING THE FLOW AND CHANGES OF TIME. THEY ARE WITNESSES OF THE GROWTH OF TIANMU MOUNTAIN AND THE EMBODIMENT OF THE ETERNAL CHARM OF NATURE. THE RINGS OF GROWTH CONTAIN THE MEMORY OF SUNSHINE AND RAIN, AS WELL AS THE SECRETS OF THE ALTERNATION OF THE FOUR SEASONS. WHILE ADMIRING IT, PEOPLE CAN'T HELP BUT FEEL AWE AND MOVED BY THE DEPTH AND MAGIC OF THE YEARS.



镂空叶子雕塑,是一件艺术品与自然相结合的杰作,以叶子为设计灵感,将大自然的生命力注入其中。通透的镂空设计展现了叶子的轻盈和透明感,仿佛叶子在微风中飘舞的画面跃然纸上。

HOLLOW LEAF SCULPTURE IS A MASTERPIECE THAT COMBINES ART WITH NATURE, INSPIRED BY LEAVES AND INFUSED WITH THE VITALITY OF NATURE. THE TRANSPARENT HOLLOW DESIGN SHOWCASES THE LIGHTNESS AND TRANSPARENCY OF THE LEAVES, AS IF THE PICTURE OF THE LEAVES DANCING IN THE BREEZE IS VIVIDLY DEPICTED ON PAPER.

感受自然，将叶子的叶脉纹理展开卷曲成一个落地艺术装置，直观的感受灯光洒下透过镂空雕刻的雕塑洒下的光影，融入空间，也呼应了大树王国的自然与生态。

Feel the nature and unfold and curl the vein texture of the leaves into a floor-standing art installation. Intuitively feel the light and shadow cast by the light through the hollow carved sculptures. Integrating into the space also echoes the nature and ecology of the big tree kingdom.

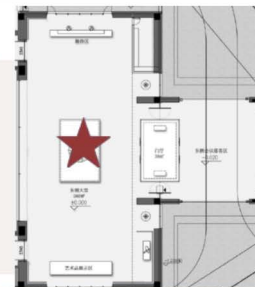

一层东侧大堂



8000

效果图展示



金属镂空雕刻+表面哑光漆



叶脉元素

感受自然,将叶子的叶脉纹理展开卷曲成一个落地艺术装置,直观的感受灯光洒下透过镂空雕刻的雕塑洒下的光影,融入空间,也呼应了大树王国的自然与生态。

FEEL THE NATURE, UNFOLD AND CURL THE VEIN TEXTURE OF THE LEAVES INTO A FLOOR-STANDING ART INSTALLATION, AND INTUITIVELY FEEL THE LIGHT SHINING THROUGH .THE LIGHT AND SHADOW CAST BY THE HOLLOW SCULPTURES BLEND INTO THE SPACE AND ECHO THE NATURE AND ECOLOGY OF THE BIG TREE KINGDOM.

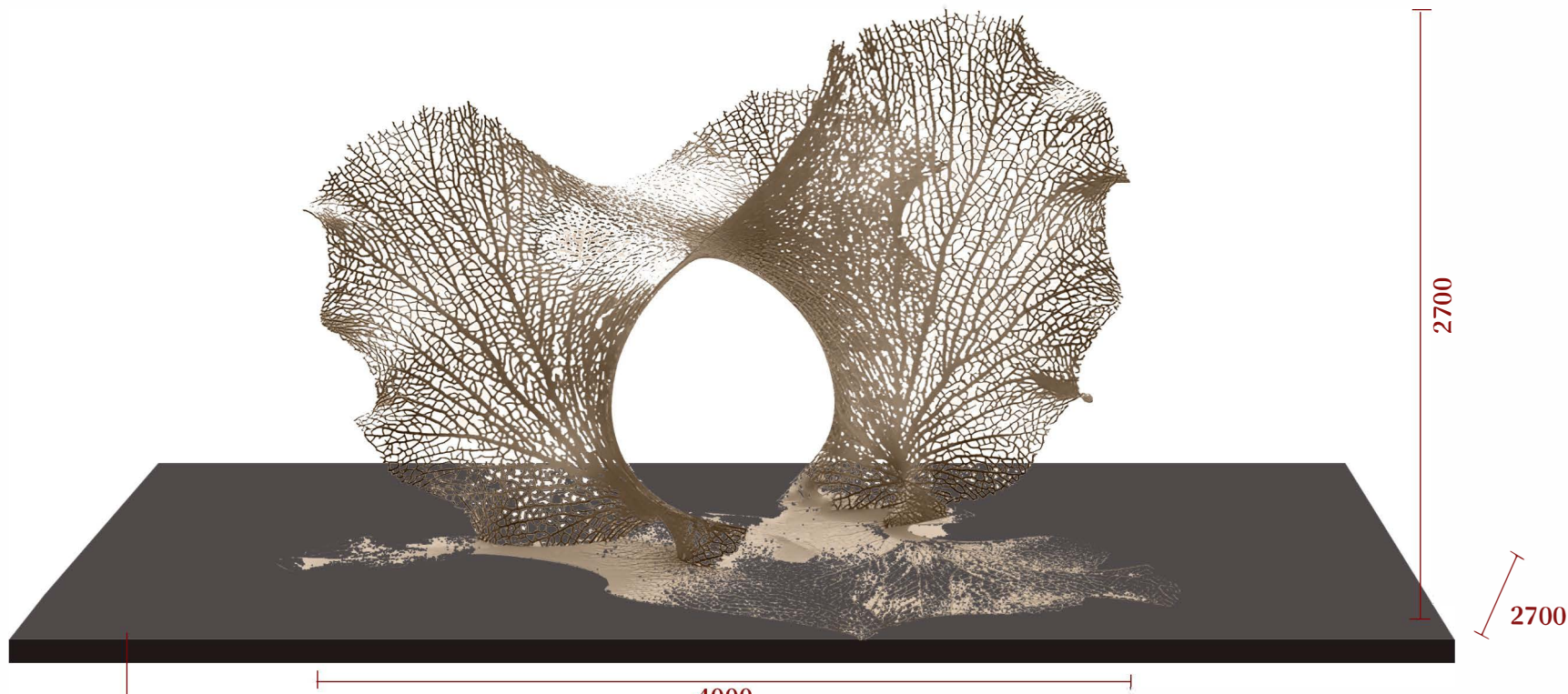

注,底座为示意,黑色底座为精装制作!

顶部灯光照射,叶脉纹理映射下来

注:

- 1、实际艺术品以中标单位现场核实具体尺寸数量再深化为准;
- 2、此点位需灯光照亮,需灯光顾问配合处理。

Furnishing articles and sculpture process requirements

摆件及雕塑工艺要求

- 1、 Art as the main theme, style, the main form of expression, need to have a strong visual impact
艺术品作为主题思想、风格的主要表现形式,需要具有很强的视觉冲击力。
- 2、 First, the designer confirmed the design, selected processing materials.
首先草图,效果图由设计师确认,选定加工材料。
- 3、 According to the site, to determine the size of the sculpture.
根据现场,图纸确定雕塑、摆件大小尺寸。
- 4、 Make mud draft, foam model, confirm the overall effect.
制作泥稿、泡沫模型,确认整体效果。
- 5、 Indoor metal art material thickness shall not be less than 1.5 mm, resin thickness shall not be less than 3mm.
金属艺术品材料壁厚室内不得低于1.5mm,树脂壁厚不得低于3mm。
- 6、 Resin artwork surface color guarantee does not fade.
树脂艺术品表面颜色保证不褪色。
- 7、 Seamless metal joints, bending polished smooth.
金属接缝处无缝隙,折弯处打磨光滑。
- 8、 摆件雕塑必须牢固、稳定、安全、与灯光很好结合。
- 9、 石材基座必须做好加重加固,以防碰撞引起倒塌。
- 10、 落地安放艺术品要稳、安全。

平面图

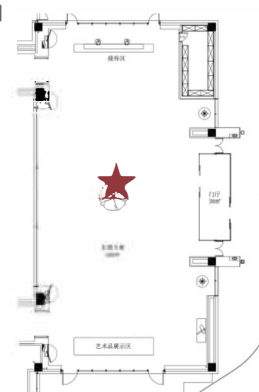

图片仅供参考,以最终效果为准。

平面示意:

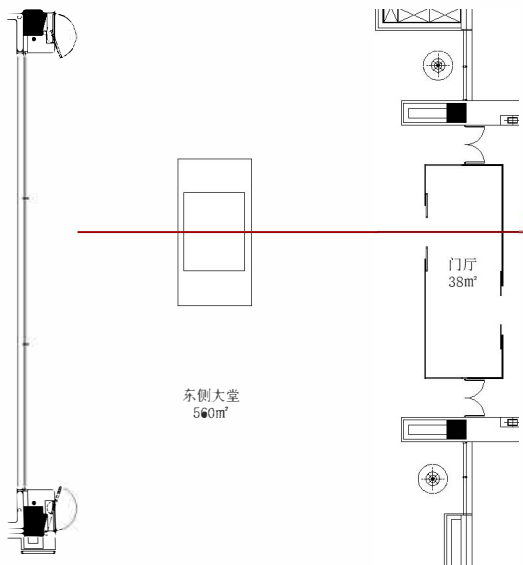

雕塑对齐门厅入口中间位置

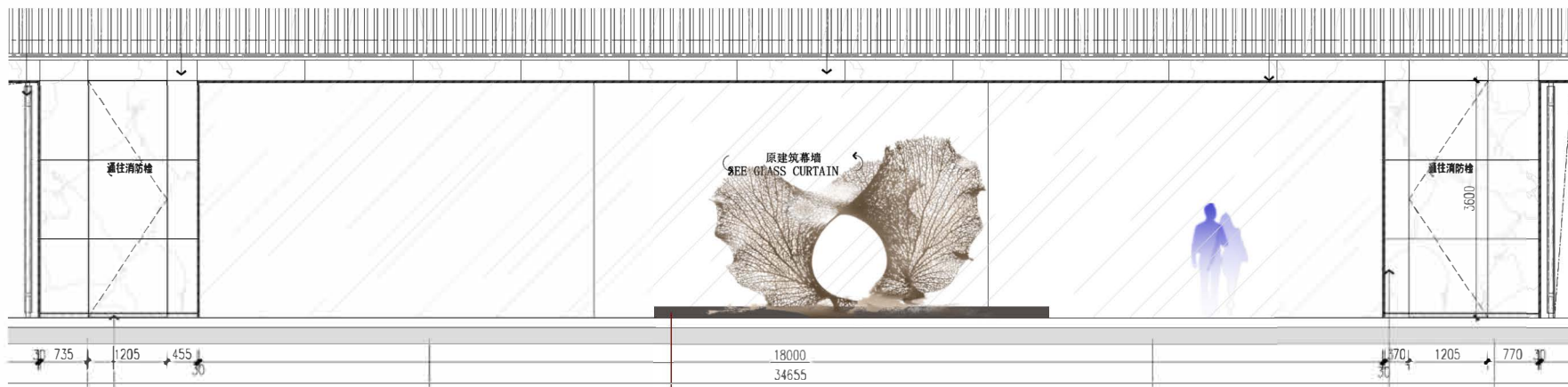
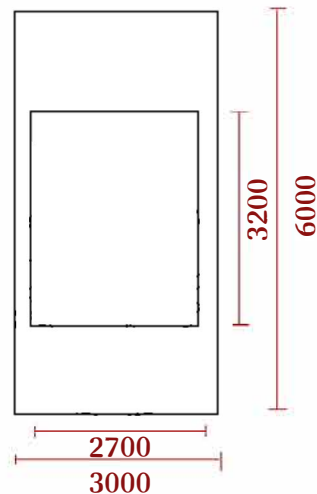

注:底座为示意, 黑色底座为精装制作!

注:

- 1、实际艺术品以中标单位现场核实具体尺寸数量再深化为准;
- 2、此点位需灯光照亮, 需灯光顾问配合处理。

Furnishing articles and sculpture process requirements

摆件及雕塑工艺要求

- 1、 Art as the main theme, style, the main form of expression, need to have a strong visual impact
艺术品作为主题思想、风格的主要表现形式, 需要具有很强的视觉冲击力。
- 2、 First, the designer confirmed the design, selected processing materials.
首先草图, 效果图由设计师确认, 选定加工材料。
- 3、 According to the site, to determine the size of the sculpture.
根据现场, 图纸确定雕塑、摆件大小尺寸。
- 4、 Make mud draft, foam model, confirm the overall effect.
制作泥稿、泡沫模型, 确认整体效果。
- 5、 Indoor metal art material thickness shall not be less than 1.5 mm, resin thickness shall not be less than 3mm.
金属艺术品材料厚度室内不得低于1.5mm,树脂壁厚度不得低于3mm。
- 6、 Resin artwork surface color guarantee does not fade.
树脂艺术品表面颜色保证不褪色。
- 7、 Seamless metal joints, bending polished smooth.
金属接缝处无缝隙, 折弯处打磨光滑。
- 8、 摆件雕塑必须牢固、稳定、安全、与灯光很好结合。
- 9、 石材基座必须做好加重加固, 以防碰撞引起倒塌。
- 10、 落地安放艺术品要稳、安全。

平面图

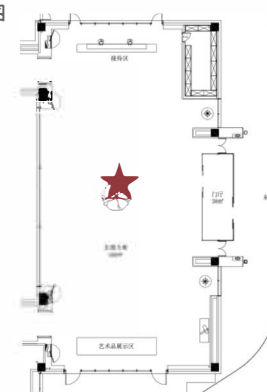

图片仅供参考, 以最终效果为准。

Project 项目名称: 杭州天目山格芮精选希尔顿酒店 Serial number 项目编号: 1F-RC-03

Material 材质: 木雕刻纹理造型+石材底座

Process description 工艺说明:

Area 区域: 一层研学中心北侧大堂

Number 数量: 1组

Size 尺寸: 雕塑: W2000*D2000*H1900,底座: W2500*D2500*H300



木质的纹理与年轮相互交织, 在光的映照下泛着温润的光泽。用手轻轻触摸, 能感受到那微微的凹凸, 仿佛能触摸到时间的流淌。它们就像是被凝固的时光切片, 散发着古朴而醇厚的气息。

THE WOOD TEXTURE AND GROWTH RINGS ARE INTERTWINED, GLOWING WITH A WARM LUSTER UNDER THE LIGHT. IF YOU TOUCH IT GENTLY WITH YOUR HAND, YOU CAN FEEL THE SLIGHT CONCAVE AND CONVEX, AS IF YOU CAN TOUCH THE FLOW OF TIME. THEY ARE LIKE SLICES OF FROZEN TIME, EXUDING A SIMPLE AND MELLOW ATMOSPHERE.

- 注:
- 1、实际艺术品以中标单位现场核实具体尺寸数量再深化为准;
 - 2、此点位需灯光照亮, 需灯光顾问配合处理。

灵感来源: 岁月年轮



材质细节:

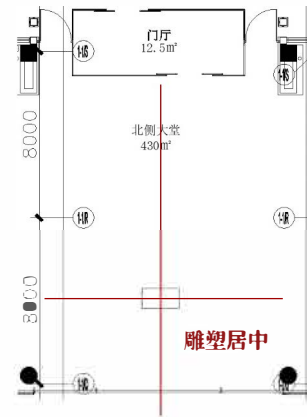

平面示意



Furnishing articles and sculpture process requirements

摆件及雕塑工艺要求

- 1、Art as the main theme, style, the main form of expression, need to have a strong visual impact
艺术品作为主题思想、风格的主要表现形式, 需要具有很强的视觉冲击力。
- 2、First, the designer confirmed the design, selected processing materials.
首先草图, 效果图由设计师确认, 选定加工材料。
- 3、According to the site, to determine the size of the sculpture. 根据现场, 图纸确定雕塑、摆件大小尺寸。
- 4、Make mud draft, foam model, confirm the overall effect. 制作泥稿、泡沫模型, 确认整体效果。
- 5、Indoor metal art material thickness shall not be less than 1.5 mm, resin thickness shall not be less than 3mm.
金属艺术品材料壁厚室内不得低于1.5mm, 树脂壁厚不得低于3mm。
- 6、Resin artwork surface color guarantee does not fade, resin artwork surface color guarantee does not fade.
- 7、Seamless metal joints, bending polished smooth.
金属接缝处无缝隙, 折弯处打磨光滑。
- 8、摆件雕塑必须牢固、稳定、安全、与灯光很好结合。
- 9、石材基座必须做好加重加固, 以防碰撞引起倒塌。
- 10、落地安放艺术品要稳、安全。

平面图



图片仅供参考, 以最终效果为准。

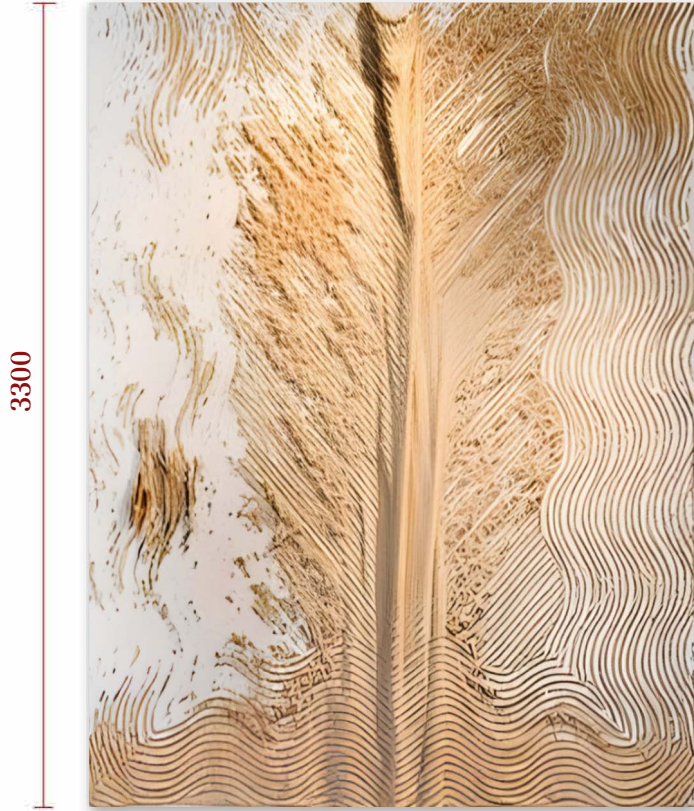

3300

2500

立体肌理堆叠的展现形式, 将树木的年轮用艺术手法表现出来。

THE DISPLAY FORM OF THREE-DIMENSIONAL TEXTURE STACKING USES ARTISTIC TECHNIQUES TO EXPRESS THE ANNUAL RINGS OF TREES.

- 注: 1、实际艺术品以中标单位现场核实具体尺寸数量再深化为准;
 2、此点位需灯光照亮, 需灯光顾问配合处理。
 3、红框为加固区域, 需墙面加固厚度18mm木工板。



灵感来源: 年轮



材质细节

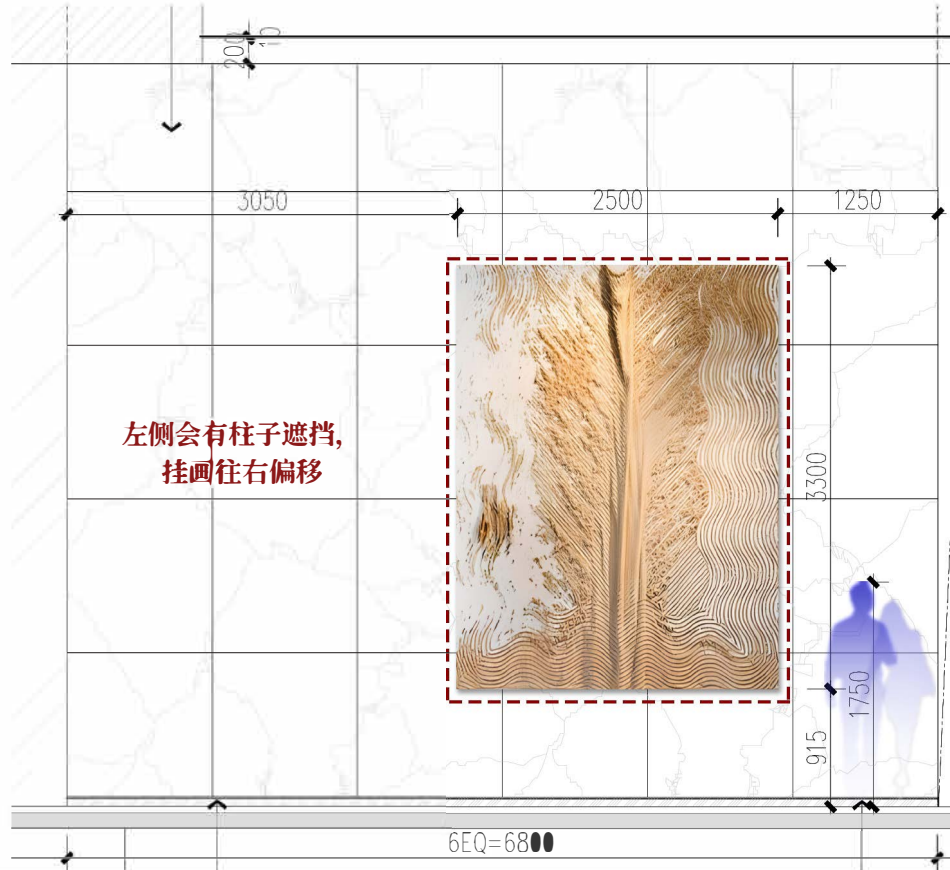

左侧会有柱子遮挡, 挂画往右偏移

Furnishing articles and sculpture process requirements

摆件及雕塑工艺要求

- 1、Art as the main theme, style, the main form of expression, need to have a strong visual impact
艺术品作为主题思想、风格的主要表现形式, 需要具有很强的视觉冲击力。
- 2、First, the designer confirmed the design, selected processing materials.
首先草图, 效果图由设计师确认, 选定加工材料。
- 3、According to the site, to determine the size of the sculpture.
根据现场, 图纸确定雕塑、摆件大小尺寸。
- 4、Make mud draft, foam model, confirm the overall effect.
制作泥稿、泡沫模型, 确认整体效果。
- 5、Indoor metal art material thickness shall not be less than 1.5 mm, resin thickness shall not be less than 3mm.
金属艺术品材料壁厚室内不得低于1.5mm, 树脂壁厚不得低于3mm。
- 6、Resin artwork surface color guarantee does not fade.
树脂艺术品表面颜色保证不褪色。
- 7、Seamless metal joints, bending polished smooth.
金属接缝处无缝隙, 折弯处打磨光滑。
- 8、摆件雕塑必须牢固、稳定、安全、与灯光很好结合。
- 9、石材基座必须做好加重加固, 以防碰撞引起倒塌。
- 10、落地安放艺术品要稳、安全。

平面图

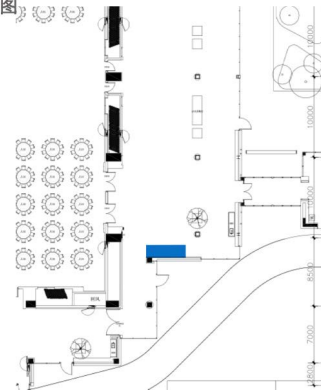

图片仅供参考, 以最终效果为准。



材质细节: 高低错落装置



50~150

底板尺寸: W1400*H570

1500



灵感来源: 散落的种子

在那一方天地中,一个个以散落的种子为元素的木雕雕刻作品悄然呈现。它们被精心雕琢成种子的形状,仿佛是从自然中直接撷取而来,带着生命最初的模样。这些木雕种子以独特的姿态组合成精美的立体装置,每一颗都蕴含着无尽的生机与可能。

IN THAT WORLD, WOOD CARVINGS WITH SCATTERED SEEDS AS ELEMENTS QUIETLY APPEARED. THEY ARE CAREFULLY CARVED INTO THE SHAPE OF SEEDS, AS IF THEY WERE TAKEN DIRECTLY FROM NATURE, WITH THE ORIGINAL APPEARANCE OF LIFE. THESE WOODCARVING SEEDS ARE COMBINED INTO EXQUISITE THREE-DIMENSIONAL INSTALLATIONS IN UNIQUE POSTURES, EACH ONE CONTAINING ENDLESS VITALITY AND POSSIBILITY.

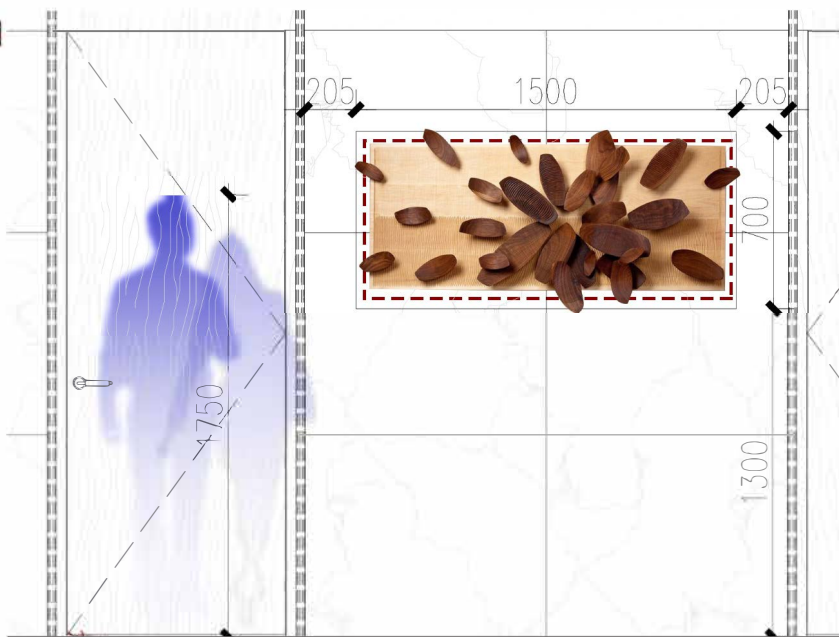

注:

- 1、实际艺术品以中标单位现场核实具体尺寸数量再深化为准;
- 2、此点位需灯光照亮,需灯光顾问配合处理。
- 3、红框位置为加固区域,需墙面加固厚度18mm木工板。

Furnishing articles and sculpture process requirements

摆件及雕塑工艺要求

- 1、Art as the main theme, style, the main form of expression, need to have a strong visual impact
艺术品作为主题思想、风格的主要表现形式,需要具有很强的视觉冲击力。
- 2、First, the designer confirmed the design, selected processing materials.
首先草图,效果图由设计师确认,选定加工材料。
- 3、According to the site, to determine the size of the sculpture. 根据现场,图纸确定雕塑、摆件大小尺寸。
- 4、Make mud draft, foam model, confirm the overall effect. 制作泥稿、泡沫模型,确认整体效果。
- 5、Indoor metal art material thickness shall not be less than 1.5 mm, resin thickness shall not be less than 3mm.
金属艺术品材料壁厚室内不得低于1.5mm,树脂壁厚度不得低于3mm。
- 6、Resin artwork surface color guarantee does not fade. 树脂艺术品表面颜色保证不褪色。
- 7、Seamless metal joints, bending polished smooth. 金属接缝处无缝隙,折弯处打磨光滑。
- 8、摆件雕塑必须牢固、稳定、安全、与灯光很好结合。
- 9、石材基座必须做好加重加固,以防碰撞引起倒掉。
- 10、落地安放艺术品要稳、安全。

平面图

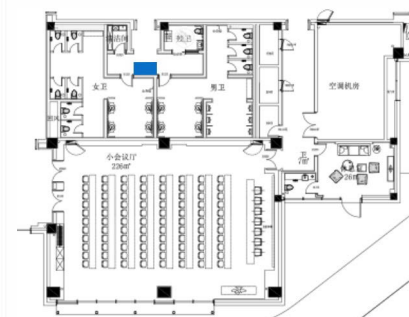

图片仅供参考,以最终效果为准。

Project 项目名称: 杭州天目山格芮精选希尔顿酒店 Serial number 项目编号: 1F-RC-06

Material 材质: 木板切割造型+层叠拼接+喷漆渐变颜色+无框直裱

Process description 工艺说明:

Area 区域: 一层研学中心北侧卫生间

Number 数量: 1件

Size 尺寸: W2000*D500*H1200

1200



材质细节

灵感来源: 树木年轮

THE WOODEN BOARDS ARE CAREFULLY CUT INTO THE WONDERFUL SHAPE OF ANNUAL RINGS. THE CIRCLES OF LINES ARE LIKE THE MYSTERIOUS MARKS LEFT BY THE YEARS, AND THE CONCAVE AND CONVEX TEXTURE IS LIKE THE UPS AND DOWNS OF THE EARTH, FULL OF SIMPLE AND REAL TOUCH. HE IS A FAITHFUL RECORDER OF THE LIFE COURSE OF TREES. THEY ARE LAYERED ON TOP OF EACH OTHER, INTERTWINING INTO A DEEP AND CHARMING PICTURE. THE ANNUAL RINGS SPREADING OUT FROM THE CENTER ARE LIKE RIPPLES, GIVING PEOPLE ENDLESS REVERIE.

木板被精心切割出年轮一圈圈的奇妙造型。那一圈圈的纹路,好似岁月留下的神秘印记,凹凸的肌理感宛如大地的起伏,充满了质朴而真实的触感。是树木生命历程的忠实记录者。它们层层叠叠,交织出一幅深邃而迷人的画卷,从中心向外扩散的年轮,宛如涟漪般荡漾开来,给人以无尽的遐想。

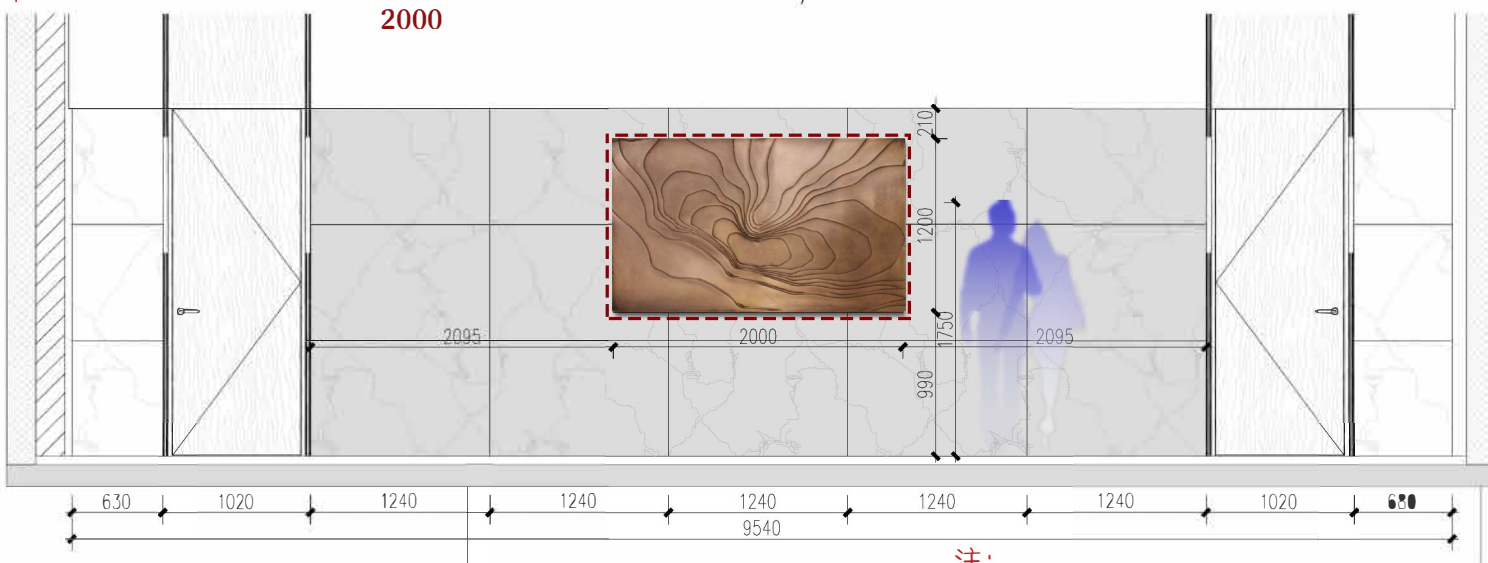

注:

- 1、实际艺术品以中标单位现场核实具体尺寸数量再深化为准;
- 2、此点位需灯光照亮,需灯光顾问配合处理。
- 3、红框位置为加固区域,需墙面加固厚度18mm木工板。

Furnishing articles and sculpture process requirements

摆件及雕塑工艺要求

1、 Art as the main theme, style, the main form of expression, need to have a strong visual impact

艺术品作为主题思想、风格的主要表现形式,需要具有很强的视觉冲击力。

2、 First, the designer confirmed the design, selected processing materials.

首先草图,效果图由设计师确认,选定加工材料。

3、 According to the site, to determine the size of the sculpture. 根据现场,图纸确定雕塑、摆件大小尺寸。

4、 Make mud draft, foam model, confirm the overall effect. 制作泥稿、泡沫模型,确认整体效果。

5、 Indoor metal art material thickness shall not be less than 1.5 mm, resin thickness shall not be less than 3mm.

金属艺术品材料壁厚室内不得低于1.5mm,树脂壁厚度不得低于3mm。

6、 Resin artwork surface color guarantee does not fade. 树脂艺术品表面颜色保证不褪色。

7、 Seamless metal joints, bending polished smooth. 金属接缝处无缝隙,折弯处打磨光滑。

8、 摆件雕塑必须牢固、稳定、安全、与灯光很好结合。

9、 石材基座必须做好加重加固,以防碰撞引起倒掉。

10、 落地安放艺术品要稳、安全。

平面图

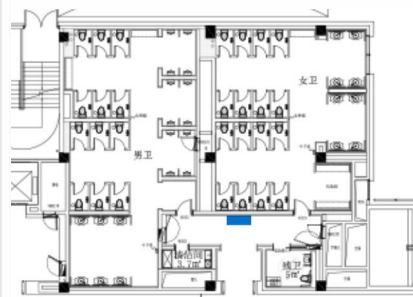

图片仅供参考,以最终效果为准。

Project 项目名称: 杭州天目山格芮精选希尔顿酒店 Serial number 项目编号: 1F-RC-07 Material 材质: 金属镂空雕刻+表面哑光漆+黑色金属底座

Process description 工艺说明:

Area 区域: 一层研学中心北侧大堂会议室

Number 数量: 1组

Size 尺寸: 雕塑: W800*D800*H2300, 底座: W2000*D1000*H30



金属镂空雕刻+表面哑光漆



叶脉元素

感受自然, 将叶子的叶脉纹理展开卷曲成一个落地艺术装置,
直观的感受灯光洒下透过
镂空雕刻的雕塑洒下的光影, 融入空间, 也呼应了大树王国的自然与生态。

FEEL THE NATURE, UNFOLD AND CURL THE VEIN TEXTURE OF THE LEAVES INTO A
FLOOR-STANDING ART INSTALLATION, AND INTUITIVELY FEEL THE LIGHT SHINING
THROUGH .THE LIGHT AND SHADOW CAST BY THE HOLLOW SCULPTURES BLEND
INTO THE SPACE AND ECHO THE NATURE AND ECOLOGY OF THE BIG TREE KINGDOM.

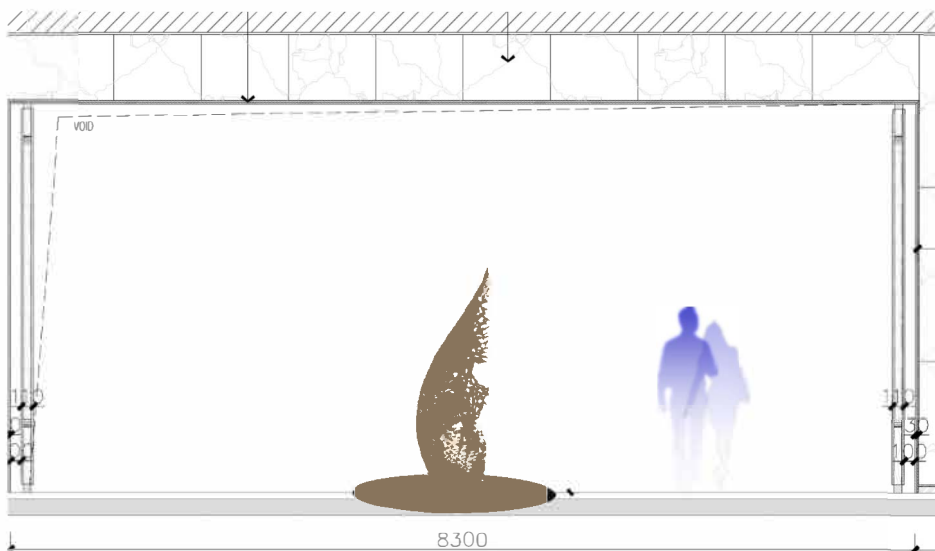

Furnishing articles and sculpture process requirements

摆件及雕塑工艺要求

1、 Art as the main theme, style, the main form of expression, need to have a strong visual impact

艺术品作为主题思想、风格的主要表现形式, 需要具有很强的视觉冲击力。

2、 First, the designer confirmed the design, selected processing materials.

首先草图, 效果图由设计师确认, 选定加工材料。

3、 According to the site, to determine the size of the sculpture. 根据现场, 图纸确定雕塑、摆件大小尺寸。

4、 Make mud draft, foam model, confirm the overall effect. 制作泥稿、泡沫模型, 确认整体效果。

5、 Indoor metal art material thickness shall not be less than 1.5 mm, resin thickness shall not be less than 3mm.

金属艺术品材料壁厚室内不得低于1.5mm, 树脂壁厚不得低于3mm。

6、 Resin artwork surface color guarantee does not fade. 树脂艺术品表面颜色保证不褪色。

7、 Seamless metal joints, bending polished smooth. 金属接缝处无缝隙, 折弯处打磨光滑。

8、 摆件雕塑必须牢固、稳定、安全、与灯光很好结合。

9、 石材基座必须做好加重加固, 以防碰撞引起倒掉。

10、 落地安放艺术品要稳、安全。

平面图

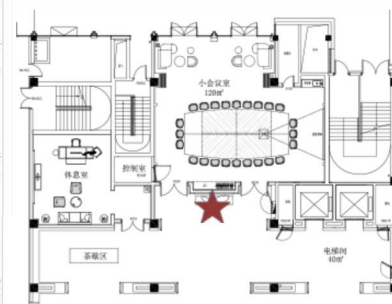

图片仅供参考, 以最终效果为准。

注:

1、实际艺术品以中标单位现场核实具体尺寸数量再深化为准;

2、此点位需灯光照亮, 需灯光顾问配合处理。

3、此艺术品后期摆放进场, 需等过了消防检查。

Project 项目名称: 杭州天目山格芮精选希尔顿酒店 Serial number 项目编号: 1F-RC-08

Material 材质: 木雕刻纹理造型+金属底座+石材底座

Process description 工艺说明:

Area 区域: 一层研学中心北侧大堂

Number 数量: 1组

Size 尺寸: 雕塑: W1200*D1200*H1100,底座: W1200*D1200*H750

木质的纹理与年轮相互交织, 在光的映照下泛着温润的光泽。用手轻轻触摸, 能感受到那微微的凹凸, 仿佛能触摸到时间的流淌。它们就像是凝固的时光切片, 散发着古朴而醇厚的气息, 让人不禁沉浸在对过去岁月的怀想与感慨之中, 思绪也随之飘向那遥远而美好的往昔。

THE WOOD TEXTURE AND GROWTH RINGS ARE INTERTWINED, GLOWING WITH A WARM LUSTER UNDER THE LIGHT. IF YOU TOUCH IT GENTLY WITH YOUR HAND, YOU CAN FEEL THE SLIGHT CONCAVE AND CONVEX, AS IF YOU CAN TOUCH THE FLOW OF TIME. THEY ARE LIKE FROZEN SLICES OF TIME, EXUDING A SIMPLE AND MELLOW ATMOSPHERE, MAKING PEOPLE IMMERSED IN NOSTALGIA AND EMOTION FOR THE PAST YEARS, AND THEIR THOUGHTS DRIFT TO THE DISTANT AND BEAUTIFUL PAST.



灵感来源: 年轮

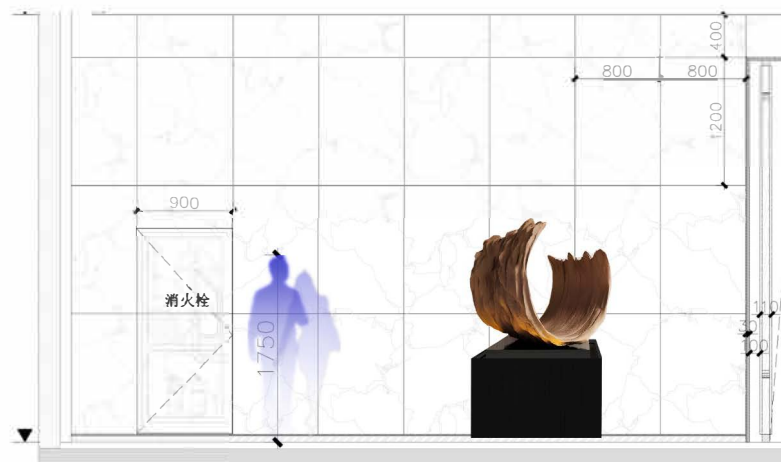
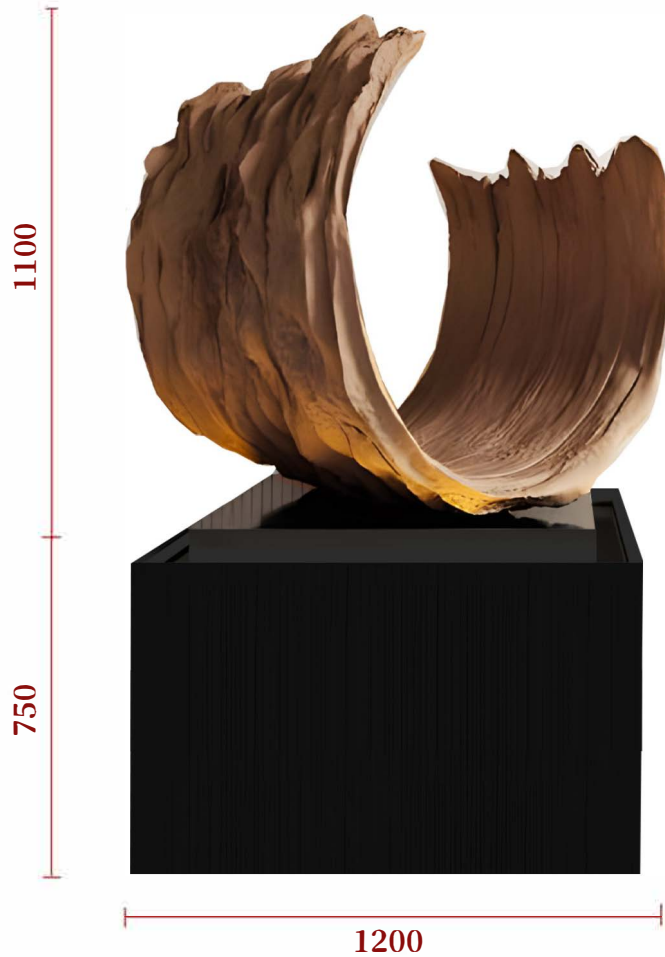

Furnishing articles and sculpture process requirements

摆件及雕塑工艺要求

- 1、Art as the main theme, style, the main form of expression, need to have a strong visual impact
艺术品作为主题思想、风格的主要表现形式, 需要具有很强的视觉冲击力。
- 2、First, the designer confirmed the design, selected processing materials.
首先草图, 效果图由设计师确认, 选定加工材料。
- 3、According to the site, to determine the size of the sculpture. 根据现场, 图纸确定雕塑、摆件大小尺寸。
- 4、Make mud draft, foam model, confirm the overall effect. 制作泥稿、泡沫模型, 确认整体效果。
- 5、Indoor metal art material thickness shall not be less than 1.5 mm, resin thickness shall not be less than 3mm.
金属艺术品材料壁厚室内不得低于1.5mm,树脂壁厚度不得低于3mm。
- 6、Resin artwork surface color guarantee does not fade. 树脂艺术品表面颜色保证不褪色。
- 7、Seamless metal joints, bending polished smooth. 金属接缝处无缝隙, 折弯处打磨光滑。
- 8、摆件雕塑必须牢固、稳定、安全、与灯光很好结合。
- 9、石材基座必须做好加重加固, 以防碰撞引起倒掉。
- 10、落地安放艺术品要稳、安全。

平面图



注: 1、实际艺术品以中标单位现场核实具体尺寸数量再深化为准;
2、此点位需灯光照亮, 需灯光顾问配合处理。
3、此艺术品后期摆放进场, 需等过了消防检查。

图片仅供参考, 以最终效果为准。

Project 项目名称: 杭州天目山格芮精选希尔顿酒店 Serial number 项目编号: 1F-RC-08

Material 材质: 哑面陶瓷热工艺造型+陶瓷上色+木质扞皮底板

Process description 工艺说明:

Area 区域: 一层研学中心新娘房70平

Number 数量: 1件

Size 尺寸: W1500*D50~150*H850



材质细节

灵感来源: 新娘捧花

在新娘房内, 那幅独特的挂画宛如一件精致的艺术品。它以柔软的毡布为载体, 通过巧妙的手工, 呈现出栩栩如生的手捧花造型, 构成了一幅充满诗意与浪漫的画卷, 为新娘房增添了一抹别样的温馨与雅致, 仿佛在轻声诉说着爱情的美好与永恒。

IN THE BRIDAL ROOM, THE UNIQUE HANGING PAINTING IS LIKE AN EXQUISITE WORK OF ART. IT USES CERAMICS AS THE CARRIER AND USES INGENUOUS THERMAL TECHNOLOGY TO PRESENT A LIFELIKE BOUQUET SHAPE, FORMING A POETIC AND ROMANTIC PICTURE, ADDING A DIFFERENT KIND OF WARMTH AND ELEGANCE TO THE BRIDAL ROOM, AS IF WHISPERING THE BEAUTY AND ETERNITY OF LOVE.

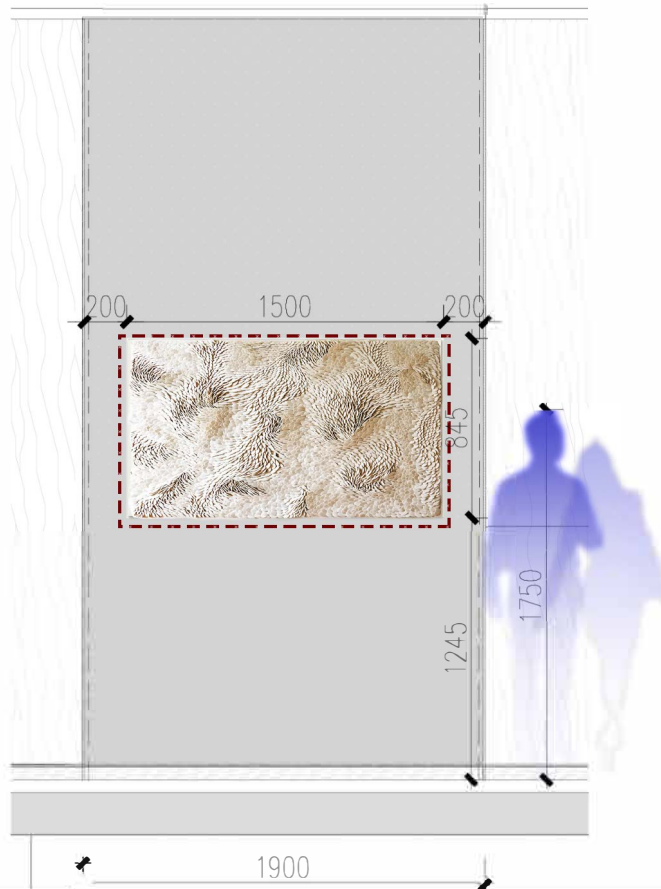

Furnishing articles and sculpture process requirements

摆件及雕塑工艺要求

- 1、Art as the main theme, style, the main form of expression, need to have a strong visual impact
艺术品作为主题思想、风格的主要表现形式, 需要具有很强的视觉冲击力。
- 2、First, the designer confirmed the design, selected processing materials.
首先草图, 效果图由设计师确认, 选定加工材料。
- 3、According to the site, to determine the size of the sculpture.
根据现场, 图纸确定雕塑、摆件大小尺寸。
- 4、Make mud draft, foam model, confirm the overall effect.
制作泥稿、泡沫模型, 确认整体效果。
- 5、Indoor metal art material thickness shall not be less than 1.5 mm, resin thickness shall not be less than 3mm.
金属艺术品材料厚度室内不得低于1.5mm, 树脂厚度不得低于3mm。
- 6、Resin artwork surface color guarantee does not fade.
树脂艺术品表面颜色保证不褪色。
- 7、Seamless metal joints, bending polished smooth.
金属接缝处无缝隙, 折弯处打磨光滑。
- 8、摆件雕塑必须牢靠、稳定、安全、与灯光很好结合。
- 9、石材基座必须做好加重加固, 以防碰撞引起倒掉。
- 10、落地安放艺术品要稳、安全。

平面图

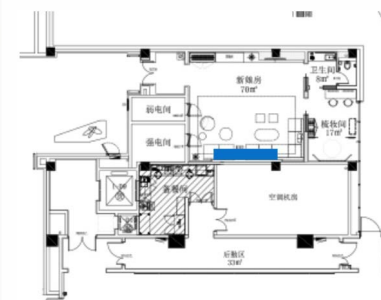

图片仅供参考, 以最终效果为准。

注:

- 1、实际艺术品以中标单位现场核实具体尺寸数量再深化为准;
- 2、此点位需灯光照亮, 需灯光顾问配合处理。
- 3、红框位置为加固区域, 需墙面加固厚度18mm木工板。

Project 项目名称: 杭州天目山格芮精选希尔顿酒店 Serial number 项目编号: 1F-RC-09

Material 材质: 哑面陶瓷热工艺造型+陶瓷上色+木质扞皮底板

Process description 工艺说明:

Area 区域: 一层研学中心新娘房75平

Number 数量: 1件

Size 尺寸: W2500*D30~150*H1200



材质细节

灵感来源: 新娘捧花

在新娘房内, 那幅独特的挂画宛如一件精致的艺术品。它以柔软的毡布为载体, 通过巧妙的手工, 呈现出栩栩如生的手捧花造型, 构成了一幅充满诗意与浪漫的画卷, 为新娘房增添了一抹别样的温馨与雅致, 仿佛在轻声诉说着爱情的美好与永恒。

IN THE BRIDAL ROOM, THE UNIQUE HANGING PAINTING IS LIKE AN EXQUISITE WORK OF ART. IT USES CERAMICS AS THE CARRIER AND USES INGENUOUS THERMAL TECHNOLOGY TO PRESENT A LIFELIKE BOUQUET SHAPE, FORMING A POETIC AND ROMANTIC PICTURE, ADDING A DIFFERENT KIND OF WARMTH AND ELEGANCE TO THE BRIDAL ROOM, AS IF WHISPERING THE BEAUTY AND ETERNITY OF LOVE.

- 注:
- 1、实际艺术品以中标单位现场核实具体尺寸数量再深化为准;
 - 2、此点位需灯光照亮, 需灯光顾问配合处理。
 - 3、红框位置为加固区域, 需墙面加固厚度18mm木工板。

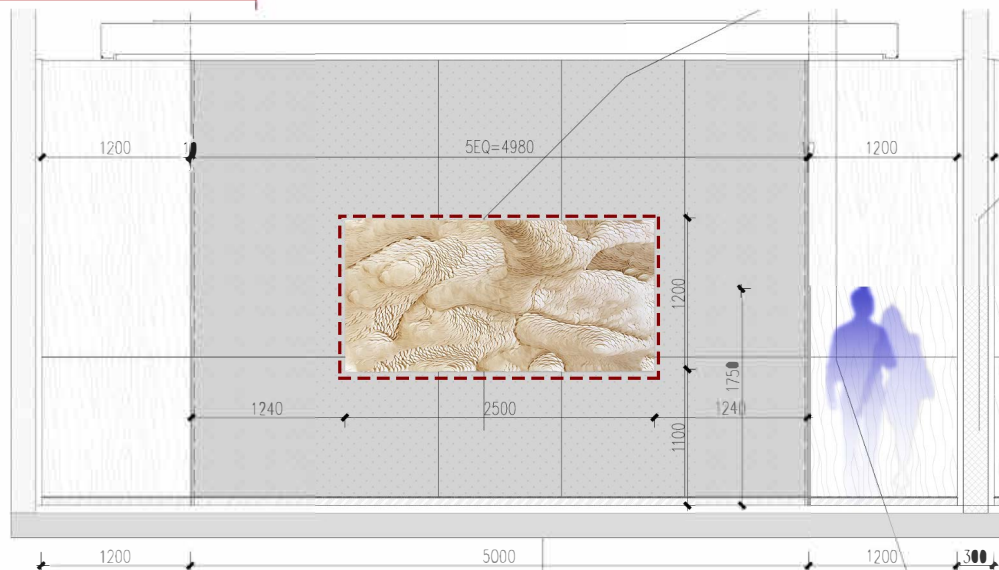

Furnishing articles and sculpture process requirements

摆件及雕塑工艺要求

- 1、Art as the main theme, style, the main form of expression, need to have a strong visual impact
艺术品作为主题思想、风格的主要表现形式, 需要具有很强的视觉冲击力。
- 2、First, the designer confirmed the design, selected processing materials.
首先草图, 效果图由设计师确认, 选定加工材料。
- 3、According to the site, to determine the size of the sculpture. 根据现场, 图纸确定雕塑、摆件大小尺寸。
- 4、Make mud draft, foam model, confirm the overall effect. 制作泥稿、泡沫模型, 确认整体效果。
- 5、Indoor metal art material thickness shall not be less than 1.5 mm, resin thickness shall not be less than 3mm.
金属艺术品材料厚度室内不得低于1.5mm, 树脂厚度不得低于3mm。
- 6、Resin artwork surface color guarantee does not fade. 树脂艺术品表面颜色保证不褪色。
- 7、Seamless metal joints, bending polished smooth. 金属接缝处无缝隙, 折弯处打磨光滑。
- 8、摆件雕塑必须牢固、稳定、安全、与灯光很好结合。
- 9、石材基座必须做好加重加固, 以防碰撞引起倒掉。
- 10、落地安放艺术品要稳、安全。

平面图



图片仅供参考, 以最终效果为准。

Project 项目名称: 杭州天目山格芮精选希尔顿酒店 Serial number 项目编号: 1F-RC-10

Material 材质: 哑面陶瓷热工艺造型+陶瓷上色+木质扞皮底板

Process description 工艺说明:

Area 区域: 一层研学中心新娘房148平

Number 数量: 1件

Size 尺寸: W2600*D50~150*H1100

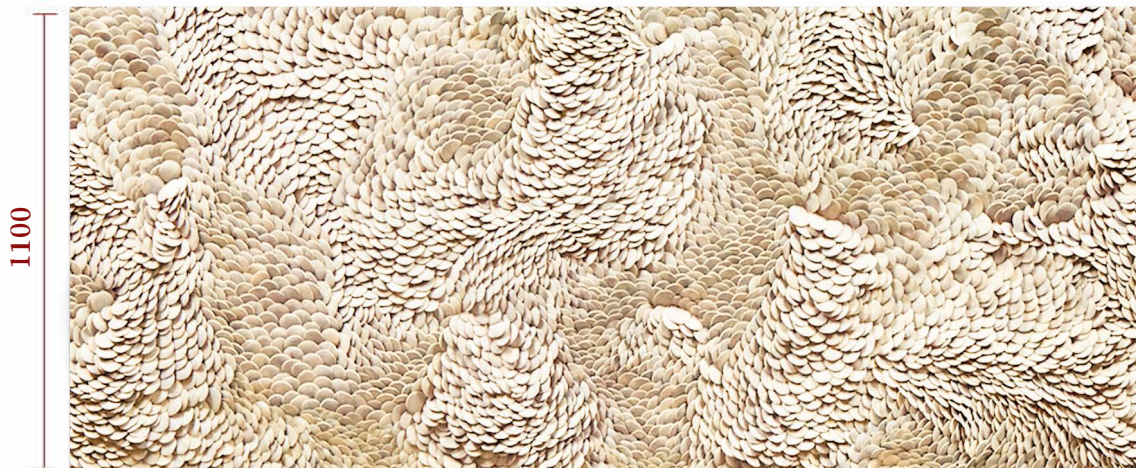

2600

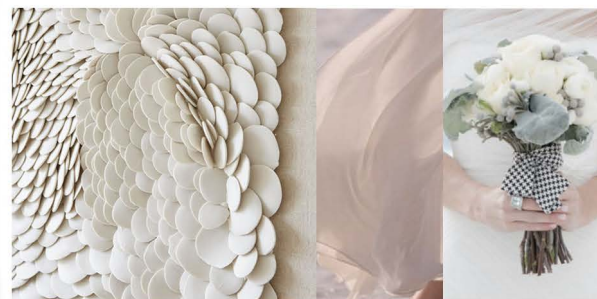

材质细节

灵感来源: 新娘捧花

在新娘房内, 那幅独特的挂画宛如一件精致的艺术品。它以柔软的毡布为载体, 通过巧妙的手工, 呈现出栩栩如生的手捧花造型, 构成了一幅充满诗意与浪漫的画卷, 为新娘房增添了一抹别样的温馨与雅致, 仿佛在轻声诉说着爱情的美好与永恒。

IN THE BRIDAL ROOM, THE UNIQUE HANGING PAINTING IS LIKE AN EXQUISITE WORK OF ART. IT USES CERAMICS AS THE CARRIER AND USES INGENUOUS THERMAL TECHNOLOGY TO PRESENT A LIFELIKE BOUQUET SHAPE, FORMING A POETIC AND ROMANTIC PICTURE, ADDING A DIFFERENT KIND OF WARMTH AND ELEGANCE TO THE BRIDAL ROOM, AS IF WHISPERING THE BEAUTY AND ETERNITY OF LOVE.

- 注:
- 1、实际艺术品以中标单位现场核实体尺寸数量再深化为准;
 - 2、此点位需灯光照亮, 需灯光顾问配合处理。
 - 3、红框位置为加固区域, 需墙面加固厚度18mm木工板。

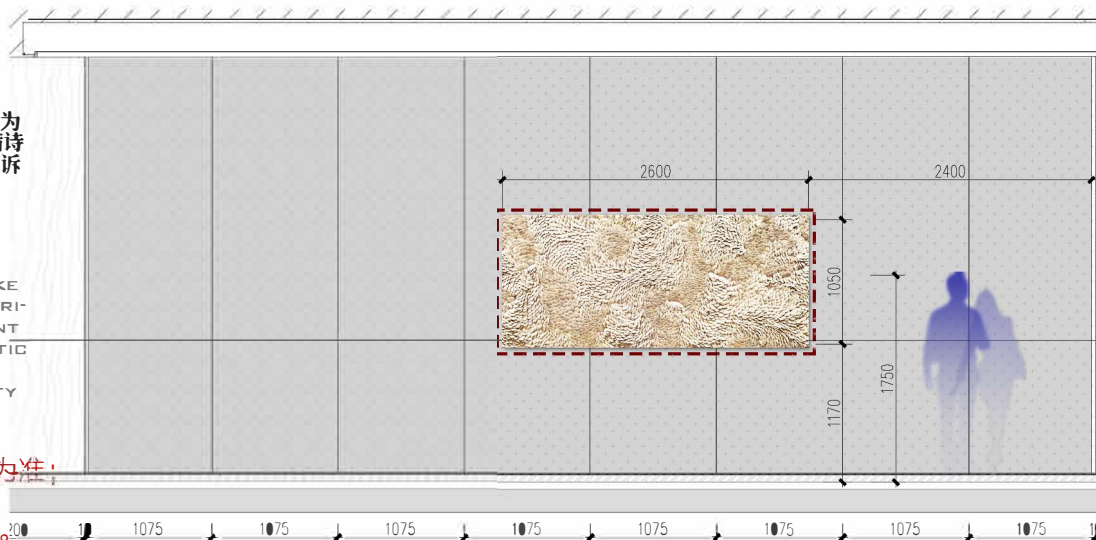

Furnishing articles and sculpture process requirements

摆件及雕塑工艺要求

- 1、Art as the main theme, style, the main form of expression, need to have a strong visual impact
艺术品作为主题思想、风格的主要表现形式, 需要具有很强的视觉冲击力。
- 2、First, the designer confirmed the design, selected processing materials.
首先草图, 效果图由设计师确认, 选定加工材料。
- 3、According to the site, to determine the size of the sculpture. 根据现场, 图纸确定雕塑、摆件大小尺寸。
- 4、Make mud draft, foam model, confirm the overall effect. 制作泥稿、泡沫模型, 确认整体效果。
- 5、Indoor metal art material thickness shall not be less than 1.5 mm, resin thickness shall not be less than 3mm.
金属艺术品材料厚度室内不得低于1.5mm,树脂厚度不得低于3mm。
- 6、Resin artwork surface color guarantee does not fade. 树脂艺术品表面颜色保证不褪色。
- 7、Seamless metal joints, bending polished smooth. 金属接缝处无缝隙, 折弯处打磨光滑。
- 8、摆件雕塑必须牢固、稳定、安全、与灯光很好结合。
- 9、石材基座必须做好加重加固, 以防碰撞引起倒塌。
- 10、落地安放艺术品要稳、安全。

平面图



图片仅供参考, 以最终效果为准。

Project 项目名称: 杭州天目山椿芮精选希尔顿酒店 Serial number 项目编号: 1F-RC-11

Material 材质: 纸浆拼接造型装置+木质底板

Process description 工艺说明:

Area 区域: 一层研学中心大会议室休息厅

Number 数量: 1件

Size 尺寸: W2000*D50*H1200



材质细节



灵感来源: 树木年轮

2000

天目山有一棵百年大树, 默默见证着时光的流转。以这棵大树的年轮为灵感, 纸工艺的精妙运用, 将一圈一圈的设计元素卷曲拼接, 如同大树的年轮在缓缓舒展。每一道卷曲, 都是对时光的温柔触摸; 每一处拼接, 都是对生命的虔诚致敬。承载着四季的更迭, 诉说着大自然的奥秘与深情。

在光与影的交织中, 这幅挂画散发着迷人的魅力。它是艺术与自然的完美融合, 是对生命不息的赞歌, 让我们在喧嚣的尘世中, 寻得一方宁静与美好。

THERE IS A CENTURY OLD TREE ON TIANMU MOUNTAIN, SILENTLY WITNESSING THE PASSAGE OF TIME. TAKING INSPIRATION FROM THE ANNUAL RINGS OF THIS LARGE TREE, THE EXQUISITE USE OF PAPER TECHNOLOGY, CURLING AND SPLICING DESIGN ELEMENTS IN CIRCLES, LIKE THE ANNUAL RINGS OF A BIG TREE SLOWLY UNFOLDING. EVERY CURL IS A GENTLE TOUCH OF TIME; EVERY STITCH IS A DEVOUT TRIBUTE TO LIFE. CARRYING THE CHANGES OF THE FOUR SEASONS, IT TELLS THE MYSTERIES AND DEEP AFFECTION OF NATURE. IN THE INTERWEAVING OF LIGHT AND SHADOW, THIS HANGING PAINTING EXUDES A CHARMING CHARM. IT IS A PERFECT FUSION OF ART AND NATURE, A HYMN TO THE ENDLESS LIFE, ALLOWING US TO FIND A PEACEFUL AND BEAUTIFUL PLACE IN THE NOISY WORLD.

- 注:
- 1、实际艺术品以中标单位现场核实具体尺寸数量再深化为准;
 - 2、此点位需灯光照亮, 需灯光顾问配合处理。
 - 3、红框位置为加固区域, 需墙面加固厚度18mm木工板。

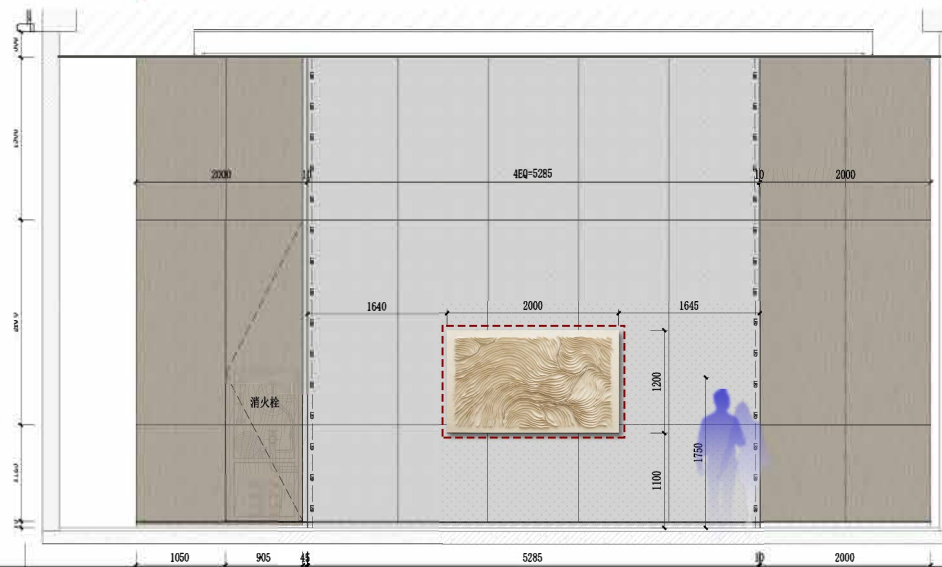

Furnishing articles and sculpture process requirements

摆件及雕塑工艺要求

1、 Art as the main theme, style, the main form of expression, need to have a strong visual impact

艺术品作为主题思想、风格的主要表现形式, 需要具有很强的视觉冲击力。

2、 First, the designer confirmed the design, selected processing materials.

首先草图, 效果图由设计师确认, 选定加工材料。

3、 According to the site, to determine the size of the sculpture. 根据现场, 图纸确定雕塑、摆件大小尺寸。

4、 Make mud draft, foam model, confirm the overall effect. 制作泥稿、泡沫模型, 确认整体效果。

5、 Indoor metal art material thickness shall not be less than 1.5 mm, resin thickness shall not be less than 3mm.

金属艺术品材料厚度室内不得低于1.5mm, 树脂厚度不得低于3mm。

6、 Resin artwork surface color guarantee does not fade. 树脂艺术品表面颜色保证不褪色。

7、 Seamless metal joints, bending polished smooth. 金属接缝处无缝隙, 折弯处打磨光滑。

8、 摆件雕塑必须牢固、稳定、安全、与灯光很好结合。

9、 石材基座必须做好加重加固, 以防碰撞引起倒掉。

10、 落地安放艺术品要稳、安全。

平面图

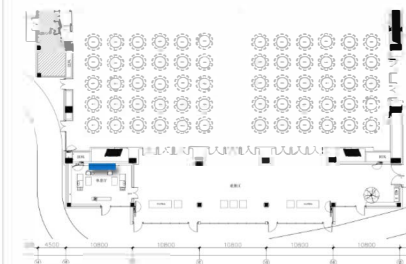

图片仅供参考, 以最终效果为准。

THE EVOLUTION OF TREES



在天目山的怀抱中，岁月流转，生命的传奇悄然上演。曾经，那高大的大树傲然挺立，如绿色的巨塔，撑起一片天空。时光雕琢，或许某些大树历经沧桑，只留下树桩，那是岁月的沉淀，一圈圈年轮诉说着过往的故事。而树干，如同生命的脊梁，即便没有了繁茂的枝叶，依然展现着坚韧的力量。从树桩到树干，再到那曾经完整的大树，它们的演变是自然的诗篇。我们将天目山的大树进行抽象艺术化，仿佛能看到那灵动的线条勾勒出大树的雄伟身姿，色彩的晕染描绘出生命的起伏与坚韧。每一道纹理都是自然的笔触，每一处转折都是时光的雕琢，让我们沉浸在这自然与艺术交织的美妙世界中，感受天目山大树的独特魅力。

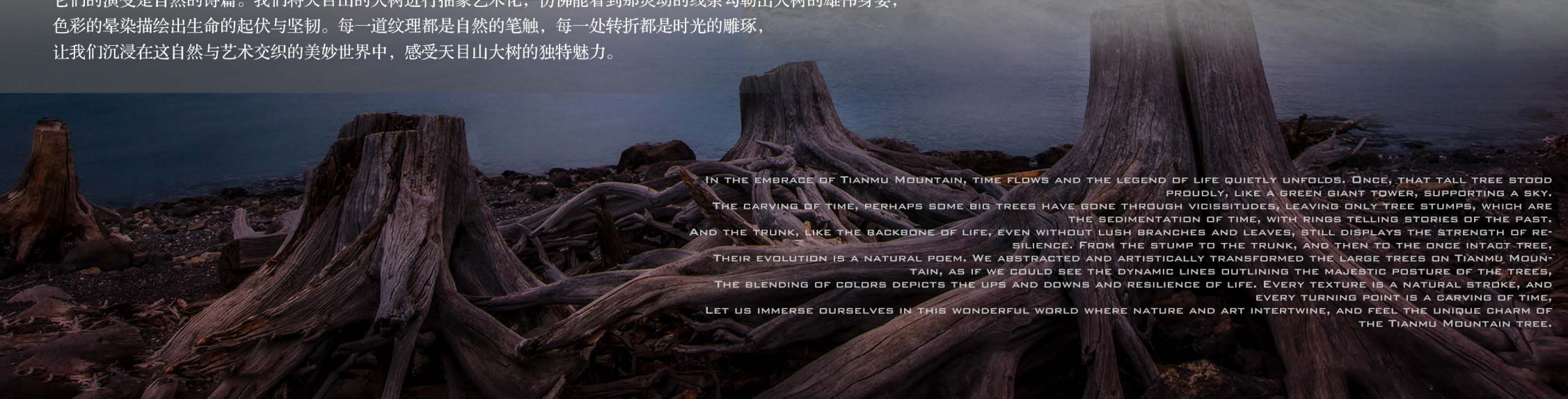

IN THE EMBRACE OF TIANMU MOUNTAIN, TIME FLOWS AND THE LEGEND OF LIFE QUIETLY UNFOLDS. ONCE, THAT TALL TREE STOOD PROUDLY, LIKE A GREEN GIANT TOWER, SUPPORTING A SKY. THE CARVING OF TIME, PERHAPS SOME BIG TREES HAVE GONE THROUGH VICISSITUDES, LEAVING ONLY TREE STUMPS, WHICH ARE THE SEDIMENTATION OF TIME, WITH RINGS TELLING STORIES OF THE PAST. AND THE TRUNK, LIKE THE BACKBONE OF LIFE, EVEN WITHOUT LUSH BRANCHES AND LEAVES, STILL DISPLAYS THE STRENGTH OF RESILIENCE. FROM THE STUMP TO THE TRUNK, AND THEN TO THE ONCE INTACT TREE, THEIR EVOLUTION IS A NATURAL POEM. WE ABSTRACTED AND ARTISTICALLY TRANSFORMED THE LARGE TREES ON TIANMU MOUNTAIN, AS IF WE COULD SEE THE DYNAMIC LINES OUTLINING THE MAJESTIC POSTURE OF THE TREES, THE BLENDING OF COLORS DEPICTS THE UPS AND DOWNS AND RESILIENCE OF LIFE. EVERY TEXTURE IS A NATURAL STROKE, AND EVERY TURNING POINT IS A CARVING OF TIME. LET US IMMERSE OURSELVES IN THIS WONDERFUL WORLD WHERE NATURE AND ART INTERTWINE, AND FEEL THE UNIQUE CHARM OF THE TIANMU MOUNTAIN TREE.

方案一:

在天目山的怀抱中, 岁月流转, 生命的传奇悄然上演。曾经, 那高大的大树傲然挺立, 如绿色的巨塔, 撑起一片天空。时光雕琢, 或许某些大树历经沧桑, 只留下树桩, 那是岁月的沉淀, 一圈圈年轮诉说着过往的故事。而树干, 如同生命的脊梁, 即便没有了繁茂的枝叶, 依然展现着坚韧的力量。从树桩到树干, 再到那曾经完整的大树, 它们的演变是自然的诗篇。我们将天目山的大树进行抽象艺术化, 仿佛能看到那灵动的线条勾勒出大树的雄伟身姿, 色彩的晕染描绘出生命的起伏与坚韧。每一道纹理都是自然的笔触, 每一处转折都是时光的雕琢, 让我们沉浸在这自然与艺术交织的美妙世界中, 感受天目山大树的独特魅力。

灵感来源: 天目树桩

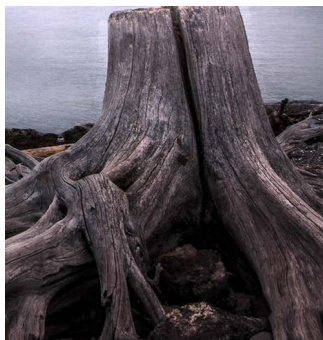

IN THE EMBRACE OF TIANMU MOUNTAIN, TIME FLOWS AND THE LEGEND OF LIFE QUIETLY UNFOLDS. ONCE, THAT TALL TREE STOOD PROUDLY, LIKE A GREEN GIANT TOWER, SUPPORTING A SKY. THE CARVING OF TIME, PERHAPS SOME BIG TREES HAVE GONE THROUGH VICISSITUDES, LEAVING ONLY TREE STUMPS, WHICH ARE THE SEDIMENTATION OF TIME, WITH RINGS TELLING STORIES OF THE PAST. AND THE TRUNK, LIKE THE BACKBONE OF LIFE, EVEN WITHOUT LUSH BRANCHES AND LEAVES, STILL DISPLAYS THE STRENGTH OF RESILIENCE. FROM THE STUMP TO THE TRUNK, AND THEN TO THE ONCE INTACT TREE. THEIR EVOLUTION IS A NATURAL POEM. WE ABSTRACTED AND ARTISTICALLY TRANSFORMED THE LARGE TREES ON TIANMU MOUNTAIN, AS IF WE COULD SEE THE DYNAMIC LINES OUTLINING THE MAJESTIC POSTURE OF THE TREES. THE BLENDING OF COLORS DEPICTS THE UPS AND DOWNS AND RESILIENCE OF LIFE. EVERY TEXTURE IS A NATURAL STROKE, AND EVERY TURNING POINT IS A CARVING OF TIME. LET US IMMERSE OURSELVES IN THIS WONDERFUL WORLD WHERE NATURE AND ART INTERTWINE, AND FEEL THE UNIQUE CHARM OF THE TIANMU MOUNTAIN TREE.

细节图片: 表面古铜色做旧



Furnishing articles and sculpture process requirements

摆件及雕塑工艺要求

- 1、Art as the main theme, style, the main form of expression, need to have a strong visual impact
艺术品作为主题思想、风格的主要表现形式, 需要具有很强的视觉冲击力。
- 2、First, the designer confirmed the design, selected processing materials.
首先草图, 效果图由设计师确认, 选定加工材料。
- 3、According to the site, to determine the size of the sculpture. 根据现场, 图纸确定雕塑、摆件大小尺寸。
- 4、Make mud draft, foam model, confirm the overall effect. 制作泥稿、泡沫模型, 确认整体效果。
- 5、Indoor metal art material thickness shall not be less than 1.5 mm, resin thickness shall not be less than 3mm.
金属艺术品材料壁厚室内不得低于1.5mm, 树脂壁厚度不得低于3mm。
- 6、Resin artwork surface color guarantee does not fade. 树脂艺术品表面颜色保证不褪色。
- 7、Seamless metal joints, bending polished smooth. 金属接缝处无缝隙, 折弯处打磨光滑。
- 8、摆件雕塑必须牢固、稳定、安全、与灯光很好结合。
- 9、石材基座必须做好加重加固, 以防碰撞引起倒掉。
- 10、落地安放艺术品要稳、安全。

平面图

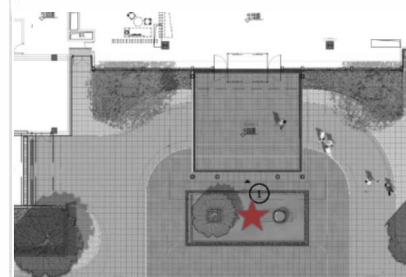

图片仅供参考, 以最终效果为准。

注: 1、实际艺术品以中标单位现场核实具体尺寸数量再深化为准;
2、此点位需灯光顾问配合灯光照明, 需在雕塑底部向上打光照亮。

Project 项目名称: 杭州天目山格芮精选希尔顿酒店 Serial number 项目编号: 1F-RC-12

Material 材质: 金属锻造雕塑造型+表面古铜色做旧喷漆

Process description 工艺说明:

Area 区域: 一层研学中心北侧大堂门口

Number 数量: 1组

Size 尺寸: W5900*D3000*H3000

效果图示意:

方案一:



立面:

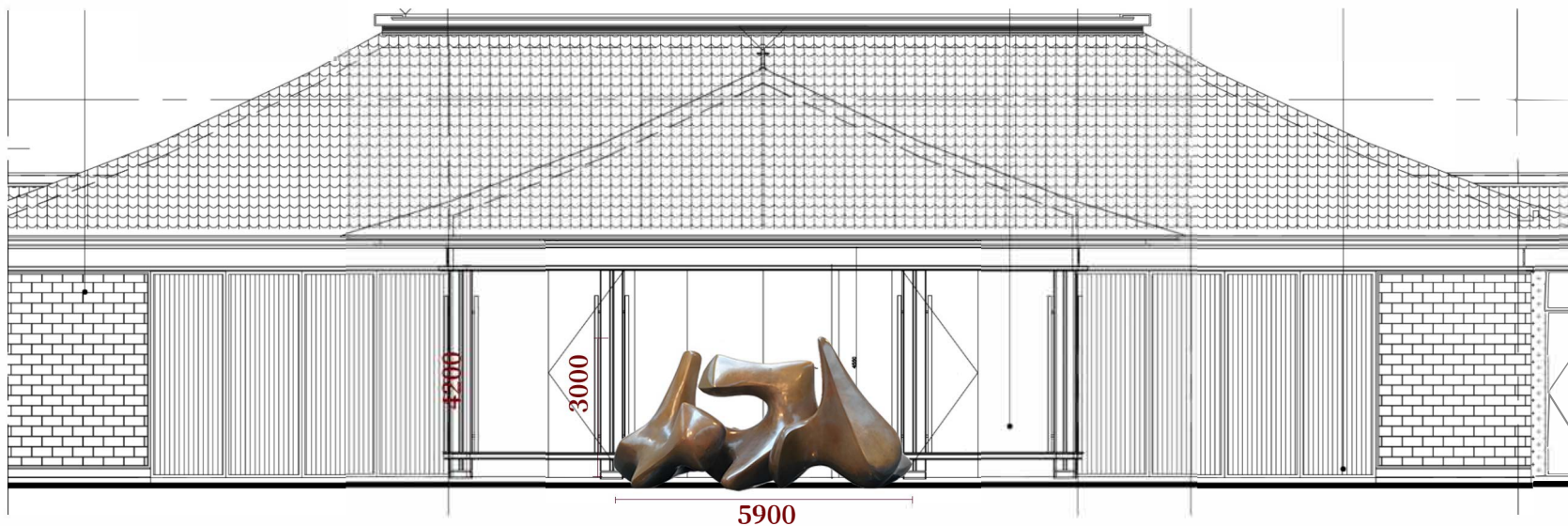

注: 1、实际艺术品以中标单位现场核实具体尺寸数量再深化为准;
 2、此点位需灯光顾问配合灯光照明, 需在雕塑底部向上打光照亮。

Furnishing articles and sculpture process requirements

摆件及雕塑工艺要求

1、 Art as the main theme, style, the main form of expression, need to have a strong visual impact

艺术品作为主题思想、风格的主要表现形式, 需要具有很强的视觉冲击力。

2、 First, the designer confirmed the design, selected processing materials.

首先草图, 效果图由设计师确认, 选定加工材料。

3、 According to the site, to determine the size of the sculpture. 根据现场, 图纸确定雕塑、摆件大小尺寸。

4、 Make mud draft, foam model, confirm the overall effect. 制作泥稿、泡沫模型, 确认整体效果。

5、 Indoor metal art material thickness shall not be less than 1.5 mm, resin thickness shall not be less than 3mm.

金属艺术品材料壁厚室内不得低于1.5mm, 树脂壁厚度不得低于3mm。

6、 Resin artwork surface color guarantee does not fade. 树脂艺术品表面颜色保证不褪色。

7、 Seamless metal joints, bending polished smooth. 金属接缝处无缝隙, 折弯处打磨光滑。

8、 摆件雕塑必须牢固、稳定、安全、与灯光很好结合。

9、 石材基座必须做好加重加固, 以防碰撞引起倒塌。

10、 落地安放艺术品要稳、安全。

平面图

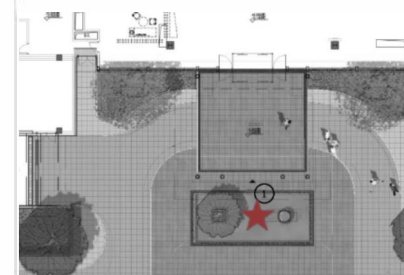

图片仅供参考, 以最终效果为准。

STAGGERED TREE ROOTS



IN THE LUSH EMBRACE OF TIANMU MOUNTAIN, INSPIRED BY THE SWIRLING ROOTS OF TREES, THE FORM WINDS AND WRAPS, AS IF IT IS A MASTERPIECE DRAWN BY NATURE WITH A MAGICAL BRUSH. THE INTERLOCKING LINES, LIKE VEINS EXTENDING FROM DEEP WITHIN THE EARTH, TELL THE STORY OF TIME AND THE RESILIENCE OF LIFE. THE SCULPTURE BLENDS SEAMLESSLY WITH THE BEAUTIFUL SCENERY OF TIANMU MOUNTAIN, SURROUNDED BY LUSH GREEN TREES AND UNDULATING MOUNTAINS, ADDING A MYSTERIOUS TOUCH TO IT. ITS EXISTENCE IS LIKE A BOND CONNECTING HEAVEN AND EARTH, IMPLYING INFINITE SPATIAL EXTENSION. EVERY BEND AND ENTANGLEMENT SEEMS TO LEAD PEOPLE'S GAZE THROUGH TIME AND SPACE, TO EXPLORE THE ENDLESS MYSTERIES. HERE, NATURE AND ART ARE PERFECTLY COMBINED, IMMERSING PEOPLE IN A PEACEFUL AND POWERFUL ATMOSPHERE, FEELING THE MAGNIFICENCE OF TIANMU MOUNTAIN AND THE DYNAMIC BEAUTY OF SCULPTURE.

在天目山的葱郁怀抱中，以盘旋的树根为灵感，形态蜿蜒缠绕，仿佛是大自然用神奇的画笔勾勒出的杰作。那交错的线条，如同大地深处延伸而出的脉络，诉说着岁月的故事和生命的坚韧。雕塑与天目山的美景融为一体，周围的绿树成荫、山峦起伏，更为它增添了一份神秘的色彩。它的存在，像是一个连接天地的纽带，暗示着无限的空间延展。每一处弯曲和缠绕，都似在引领着人们的目光穿越时空，去探寻那无尽的奥秘。在这里，自然与艺术完美结合，让人沉浸在一种宁静而又充满力量的氛围中，感受着天目山的雄浑与雕塑的灵动之美。

Project 项目名称: 杭州天目山格芮精选希尔顿酒店 Serial number 项目编号: 1F-RC-12

Material 材质: 金属锻造雕塑造型+表面古铜色做旧喷漆+黑色金属底座

Process description 工艺说明:

Area 区域: 一层研学中心北侧大堂门口

Number 数量: 1组

Size 尺寸: W5300*D3300*H3300

灵感来源: 盘根错节

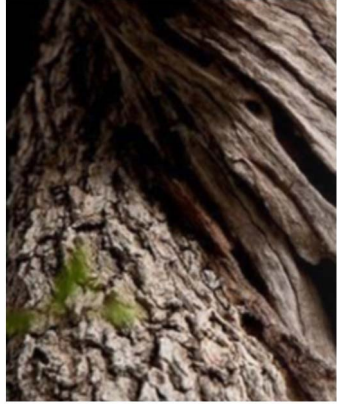

细节材质: 金属锻造表面古铜色做旧



方案二:

在天目山的葱郁怀抱中，以盘旋的树根为灵感，形态蜿蜒缠绕，仿佛是大自然用神奇的画笔勾勒出的杰作。那交错的线条，如同大地深处延伸而出的脉络，诉说着岁月的故事和生命的坚韧。雕塑与天目山的美景融为一体，周围的绿树成荫、山峦起伏，更为它增添了一份神秘的色彩。它的存在，像是一个连接天地的纽带，暗示着无限的空间延展。每一处弯曲和缠绕，都似在引领着人们的目光穿越时空，去探寻那无尽的奥秘。在这里，自然与艺术完美结合，让人沉浸在一种宁静而又充满力量的氛围中，感受着天目山的雄浑与雕塑的灵动之美。

IN THE LUSH EMBRACE OF TIANMU MOUNTAIN, INSPIRED BY THE SWIRLING ROOTS OF TREES, THE FORM WINDS AND WRAPS, AS IF IT IS A MASTERPIECE DRAWN BY NATURE WITH A MAGICAL BRUSH. THE INTERLOCKING LINES, LIKE VEINS EXTENDING FROM DEEP WITHIN THE EARTH, TELL THE STORY OF TIME AND THE RESILIENCE OF LIFE. THE SCULPTURE BLENDS SEAMLESSLY WITH THE BEAUTIFUL SCENERY OF TIANMU MOUNTAIN, SURROUNDED BY LUSH GREEN TREES AND UNDLATING MOUNTAINS, ADDING A MYSTERIOUS TOUCH TO IT. ITS EXISTENCE IS LIKE A BOND CONNECTING HEAVEN AND EARTH, IMPLYING INFINITE SPATIAL EXTENSION. EVERY BEND AND ENTANGLEMENT SEEMS TO LEAD PEOPLE'S GAZE THROUGH TIME AND SPACE, TO EXPLORE THE ENDLESS MYSTERIES. HERE, NATURE AND ART ARE PERFECTLY COMBINED, IMMERSING PEOPLE IN A PEACEFUL AND POWERFUL ATMOSPHERE, FEELING THE MAJESTY OF TIANMU MOUNTAIN AND THE DYNAMIC BEAUTY OF SCULPTURE.



Furnishing articles and sculpture process requirements

摆件及雕塑工艺要求

- 1、Art as the main theme, style, the main form of expression, need to have a strong visual impact
艺术品作为主题思想、风格的主要表现形式，需要具有很强的视觉冲击力。
- 2、First, the designer confirmed the design, selected processing materials.
首先草图，效果图由设计师确认，选定加工材料。
- 3、According to the site, to determine the size of the sculpture. 根据现场，图纸确定雕塑、摆件大小尺寸。
- 4、Make mud draft, foam model, confirm the overall effect. 制作泥稿、泡沫模型，确认整体效果。
- 5、Indoor metal art material thickness shall not be less than 1.5 mm, resin thickness shall not be less than 3mm.
金属艺术品材料壁厚室内不得低于1.5mm,树脂壁厚不得低于3mm。
- 6、Resin artwork surface color guarantee does not fade. 树脂艺术品表面颜色保证不褪色。
- 7、Seamless metal joints, bending polished smooth. 金属接缝处无缝隙，折弯处打磨光滑。
- 8、摆件雕塑必须牢固、稳定、安全、与灯光很好结合。
- 9、石材基座必须做好加重加固，以防碰撞引起倒掉。
- 10、落地安放艺术品要稳、安全。

平面图

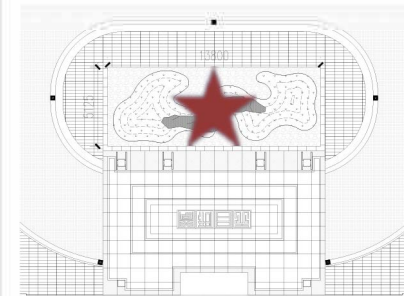

图片仅供参考，以最终效果为准。

注：1、实际艺术品以中标单位现场核具体尺寸数量再深化为准；
2、此点位需灯光顾问配合灯光照明，需在雕塑底部向上打光照亮。

Project 项目名称: 杭州天目山格芮精选希尔顿酒店 Serial number 项目编号: 1F-RC-12

Material 材质: 金属锻造雕塑造型+表面古铜色做旧喷漆

Process description 工艺说明:

Area 区域: 一层研学中心北侧大堂门口

Number 数量: 1组

Size 尺寸: W5300*D3300*H3300

方案二:

效果图示意:



立面:

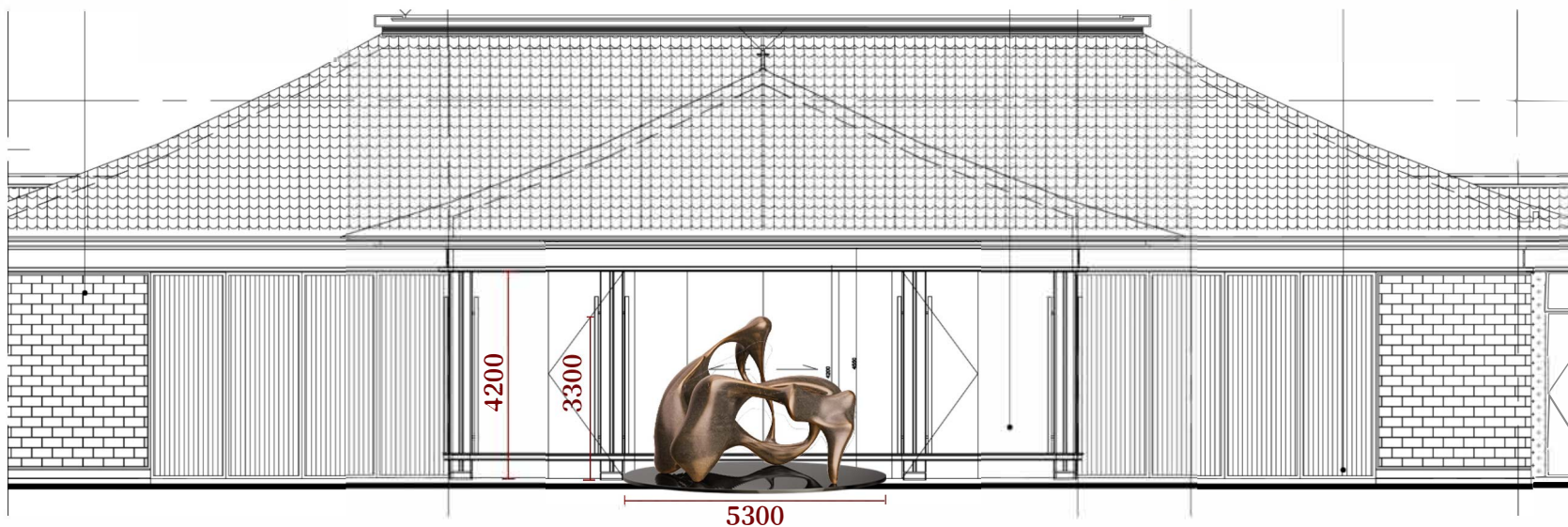

注: 1、实际艺术品以中标单位现场核实具体尺寸数量再深化为准;
 2、此点位需灯光顾问配合灯光照明, 需在雕塑底部向上打光照亮。

Furnishing articles and sculpture process requirements

摆件及雕塑工艺要求

1、 Art as the main theme, style, the main form of expression, need to have a strong visual impact

艺术品作为主题思想、风格的主要表现形式, 需要具有很强的视觉冲击力。

2、 First, the designer confirmed the design, selected processing materials.

首先草图, 效果图由设计师确认, 选定加工材料。

3、 According to the site, to determine the size of the sculpture. 根据现场, 图纸确定雕塑、摆件大小尺寸。

4、 Make mud draft, foam model, confirm the overall effect. 制作泥稿、泡沫模型, 确认整体效果。

5、 Indoor metal art material thickness shall not be less than 1.5 mm, resin thickness shall not be less than 3mm.

金属艺术品材料壁厚室内不得低于1.5mm, 树脂壁厚度不得低于3mm。

6、 Resin artwork surface color guarantee does not fade. 树脂艺术品表面颜色保证不褪色。

7、 Seamless metal joints, bending polished smooth. 金属接缝处无缝隙, 折弯处打磨光滑。

8、 摆件雕塑必须牢固、稳定、安全、与灯光很好结合。

9、 石材基座必须做好加重加固, 以防碰撞引起倒塌。

10、 落地安放艺术品要稳、安全。

平面图

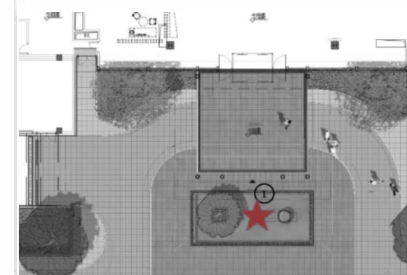

图片仅供参考, 以最终效果为准。



客房区



GUEST ROOM AREA

<枝繁叶茂>

with luxuriant foliage

ECOLOGICAL FOREST



如果说古老银杏是天目山的魂，那么，山峻水悍，奇丽秀绝，峰崖竦叠，烟峦滴翠，
名胜淹没其中，是天目山的真实写照。
站在天目山的四面峰，俯瞰纵横起伏的林貌，柳杉、银杏、连香树、领春木、金钱松和羊角槭组成的古老风景林。

If the ancient ginkgo is the soul of Tianmu Mountain, then the mountains are steep and the water is fierce, the mountains are beautiful and beautiful, the peaks and cliffs are stacked, and the mountains are covered with green smoke. The scenic spots are submerged in it, which is a true portrayal of Tianmu Mountain. Standing on the four peaks of Tianmu Mountain, you can overlook the undulating forest landscape, an ancient landscape forest composed of cryptomeria, ginkgo, sycamore, springwood, golden pine and maple.



K-1、K-1A客房效果图

K-1 AND K-1A GUEST ROOM RENDERINGS



K-1、K-1A客房洗手间效果图

K-1 AND K-1A GUEST ROOM RESTROOM RENDERINGS

Guestrooms K-1

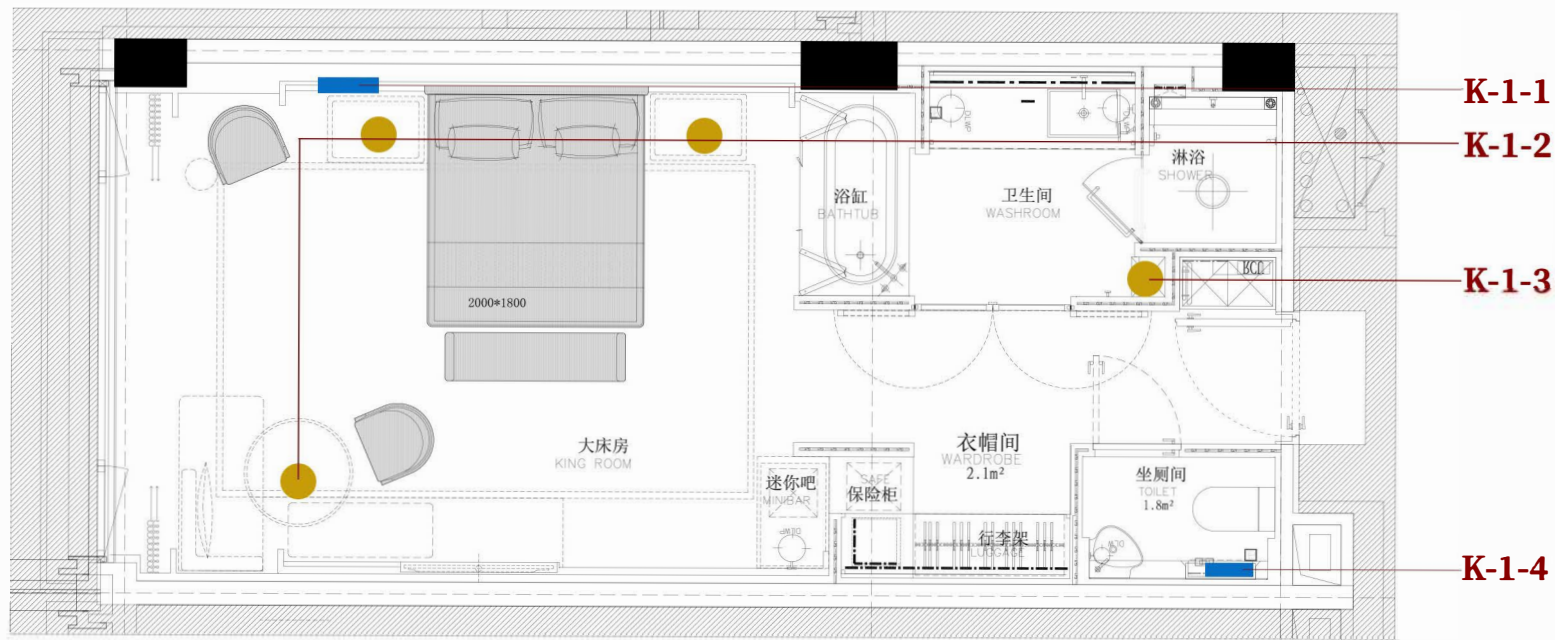

K-1、K-1A客房

- | | | | |
|----|---|----|---|
| 挂画 | ▭ | A级 | ● |
| 雕塑 | ☆ | B级 | ● |
| 摆件 | ○ | C级 | ● |

注：所有艺术品点位位置需要灯光配合

DD-1 Guest Room

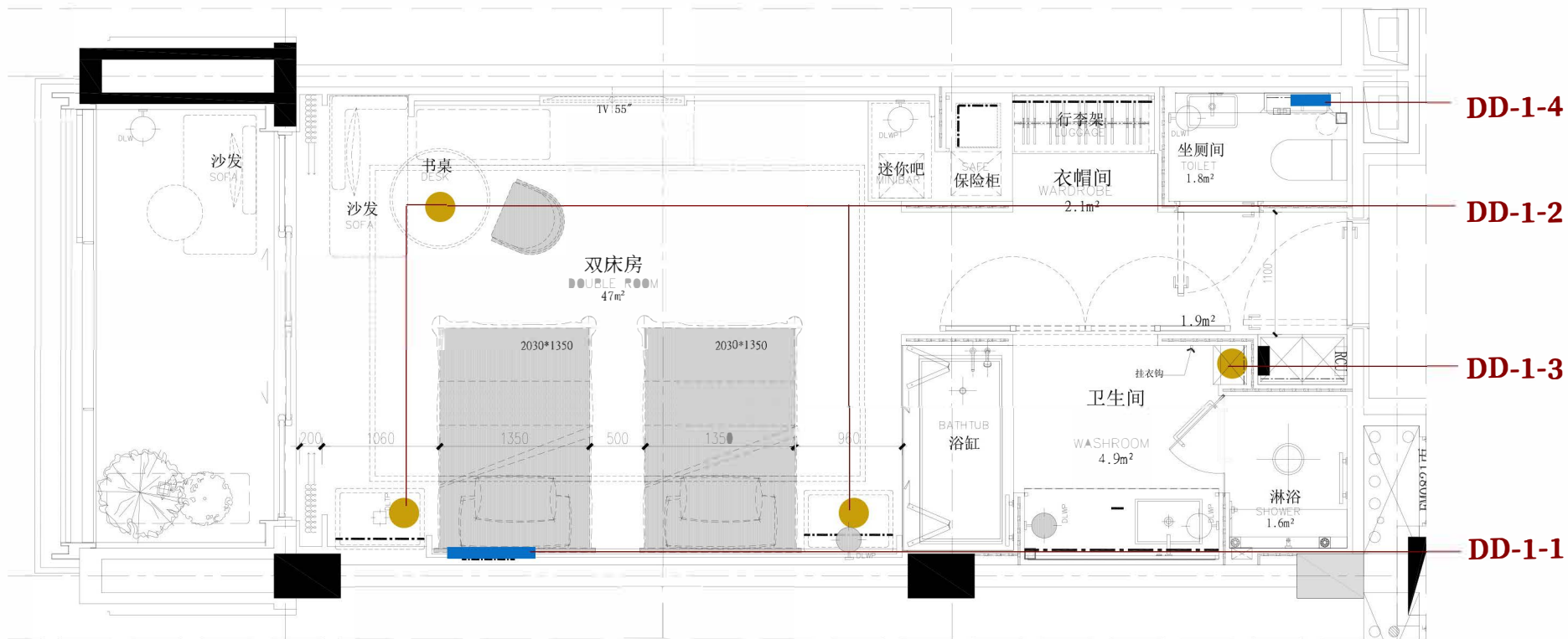

DD-1、OK客房

- 挂画 A级
- 雕塑 B级
- 摆件 C级

注：所有艺术品点位位置需要灯光配合

Project 项目名称: 杭州天目山格芮精选希尔顿酒店 Serial number 项目编号: KK-1-1,DD-1-1

Material 材质: 立体肌理+肌理画布+白色底板+深棕色木框

Process description 工艺说明:

Area 区域: 客房

Number 数量: 165件 (房型详见清单)

Size 尺寸: W350*D30*H350,W700*D30*H350

画芯厚度3mm

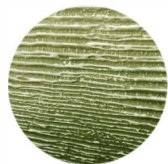

立体肌理

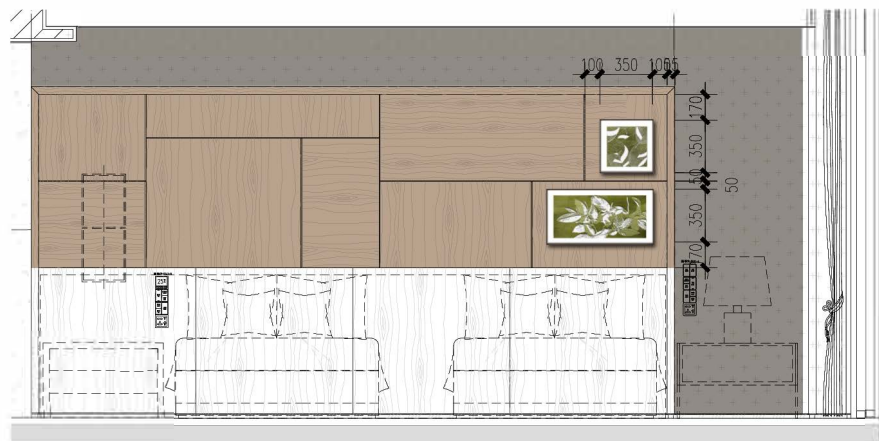
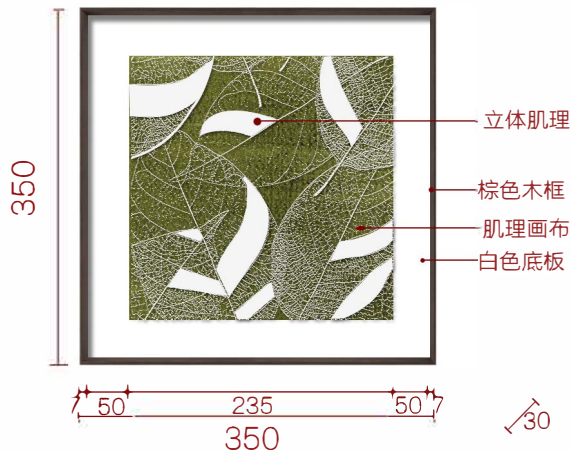

安装示意

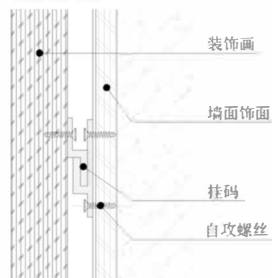

灵感来源: 天目铁木



Furnishing articles and sculpture process requirements

摆件及雕塑工艺要求

- 1、Art as the main theme, style, the main form of expression, need to have a strong visual impact
艺术品作为主题思想、风格的主要表现形式, 需要具有很强的视觉冲击力。
- 2、First, the designer confirmed the design, selected processing materials.
首先草图, 效果图由设计师确认, 选定加工材料。
- 3、According to the site, to determine the size of the sculpture.
根据现场, 图纸确定雕塑、摆件大小尺寸。
- 4、Make mud draft, foam model, confirm the overall effect.
制作泥稿、泡沫模型, 确认整体效果。
- 5、Indoor metal art material thickness shall not be less than 1.5 mm, resin thickness shall not be less than 3mm.
金属艺术品材料壁厚室内不得低于1.5mm,树脂壁厚度不得低于3mm。
- 6、Resin artwork surface color guarantee does not fade.
树脂艺术品表面颜色保证不褪色。
- 7、Seamless metal joints, bending polished smooth.
金属接缝处无缝隙, 折弯处打磨光滑。
- 8、摆件雕塑必须牢固、稳定、安全、与灯光很好结合。
- 9、石材基座必须做好加重加固, 以防碰撞引起倒塌。
- 10、落地安放艺术品要稳、安全。

平面图



DD-1数量为: 120件



DK无障碍房: 3件
 K-1: 32件, K-1A: 10件
 共: 3+32+10=45件
 图片仅供参考, 以最终效果为准。

以天目铁木树叶团簇以及飘散的黄色叶子为主题的挂画, 仿佛是自然风景的写照, 取了一处景色框写在客房中, 能够感受大自然的美妙。

注: 1、实际艺术品以中标单位现场核实具体尺寸数量再深化为准;
 2、此点位需灯光照亮, 需灯光顾问配合处理。

Project 项目名称: 杭州天目山格芮精选希尔顿酒店 Serial number 项目编号: DD-1-2、K-1-2

Material 材质: 真书书籍

Process description 工艺说明:

Area 区域: 客房

Number 数量: 660件 (房型详见清单)

Size 尺寸: 常规尺寸



书桌2件, 床头柜各1件, 共4件。

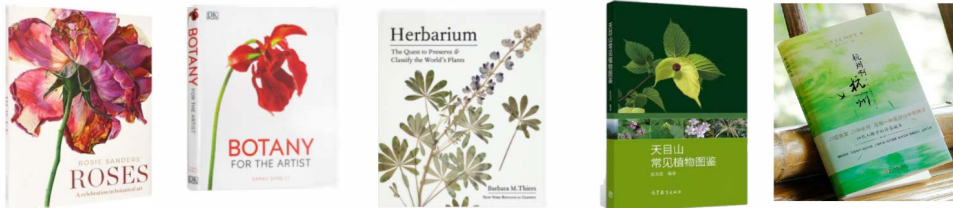

- 书籍选型:
- 1、罗西桑德斯的玫瑰 Rosie Sanders'Roses
 - 2、艺术家的植物学 Botany for the Artist DK
 - 3、植物标本室Herbarium
 - 4、天目山常见植物图鉴
 - 5、杭州啊杭州



Furnishing articles and sculpture process requirements

摆件及雕塑工艺要求

- 1、 Art as the main theme, style, the main form of expression, need to have a strong visual impact
艺术品作为主题思想、风格的主要表现形式, 需要具有很强的视觉冲击力。
- 2、 First, the designer confirmed the design, selected processing materials.
首先草图, 效果图由设计师确认, 选定加工材料。
- 3、 According to the site, to determine the size of the sculpture. 根据现场, 图纸确定雕塑、摆件大小尺寸。
- 4、 Make mud draft, foam model, confirm the overall effect. 制作泥稿、泡沫模型, 确认整体效果。
- 5、 Indoor metal art material thickness shall not be less than 1.5 mm, resin thickness shall not be less than 3mm.
金属艺术品材料壁厚室内不得低于1.5mm,树脂壁厚不得低于3mm。
- 6、 Resin artwork surface color guarantee does not fade. 树脂艺术品表面颜色保证不褪色。
- 7、 Seamless metal joints, bending polished smooth. 金属接缝处无缝隙, 折弯处打磨光滑。
- 8、 摆件雕塑必须牢固、稳定、安全、与灯光很好结合。
- 9、 石材基座必须做好加重加固, 以防碰撞引起倒掉。
- 10、 落地安放艺术品要稳、安全。

平面图



DD-1数量为: 120间*4=480件
DK数量为: 3间*4=12件

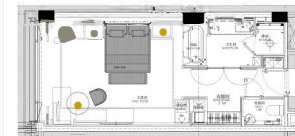

K-1数量为: 32间*4=128件
K-1A数量为: 10间*4=40件
图片仅供参考, 以最终效果为准。

注: 1、实际艺术品以中标单位现场核实具体尺寸数量再深化为准。
2、此点位金属摆件仅在样板间中展示, 整个客房区域内不提供。

Project 项目名称: 杭州天目山格芮精选希尔顿酒店 Serial number 项目编号: DD-1-3

Material 材质: 陶瓷

Process description 工艺说明:

Area 区域: 客房

Number 数量: 165组 (每组两件)

Size 尺寸: W160*H300,W180*H180

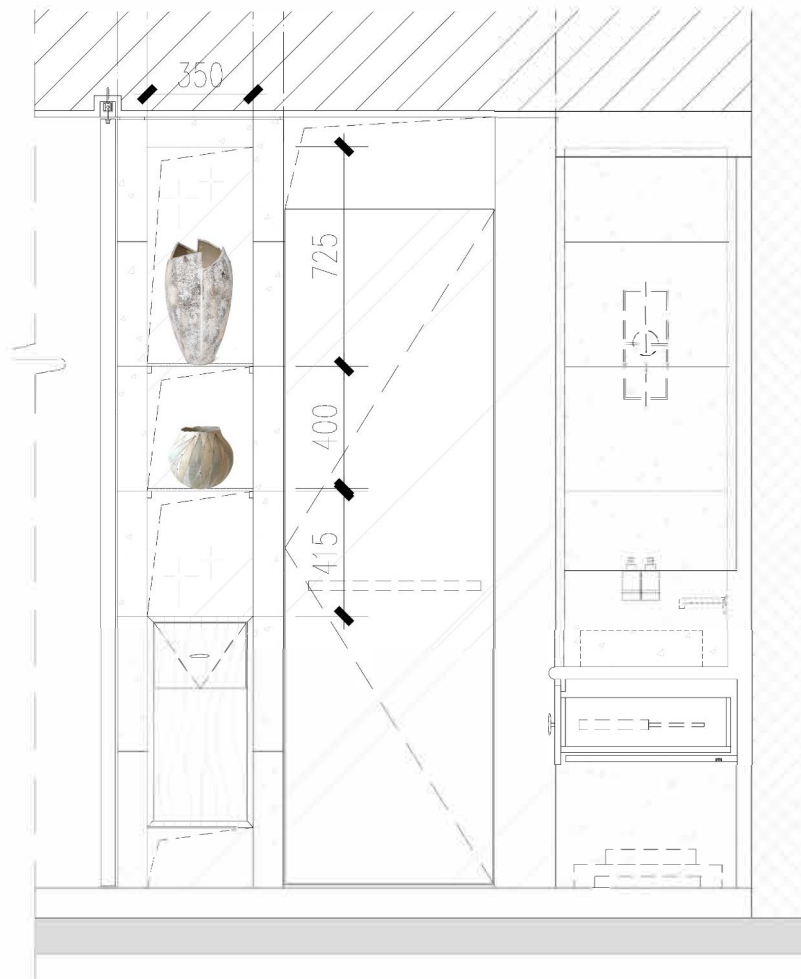

Furnishing articles and sculpture process requirements

摆件及雕塑工艺要求

- 1、 Art as the main theme, style, the main form of expression, need to have a strong visual impact
艺术品作为主题思想、风格的主要表现形式, 需要具有很强的视觉冲击力。
- 2、 First, the designer confirmed the design, selected processing materials.
首先草图, 效果图由设计师确认, 选定加工材料。
- 3、 According to the site, to determine the size of the sculpture.
根据现场, 图纸确定雕塑、摆件大小尺寸。
- 4、 Make mud draft, foam model, confirm the overall effect.
制作泥稿、泡沫模型, 确认整体效果。
- 5、 Indoor metal art material thickness shall not be less than 1.5 mm, resin thickness shall not be less than 3mm.
金属艺术品材料壁厚室内不得低于1.5mm,树脂壁厚不得低于3mm。
- 6、 Resin artwork surface color guarantee does not fade.
树脂艺术品表面颜色保证不褪色。
- 7、 Seamless metal joints, bending polished smooth.
金属接缝处无缝隙, 折弯处打磨光滑。
- 8、 摆件雕塑必须牢固、稳定、安全、与灯光很好结合。
- 9、 石材基座必须做好加重加固, 以防碰撞引起倒掉。
- 10、 落地安放艺术品要稳、安全。

平面图



DD-1数量为: 120间, DK: 3间



k-1数量为: 32间, K-1A: 10间

图片仅供参考, 以最终效果为准。

注: 1、实际艺术品以中标单位现场核实具体尺寸数量再深化为准;
2、此点位需灯光照亮, 需灯光顾问配合处理。

Project 项目名称: 杭州天目山格芮精选希尔顿酒店 Serial number 项目编号: K-1-4、D-1-4

Material 材质: 立体肌理+喷绘画面+深棕色木框

Process description 工艺说明:

Area 区域: 客房

Number 数量: 165件

Size 尺寸: W250*D30*H250



250

250

立体肌理

深棕色木框

建议灯光从上往下打光。

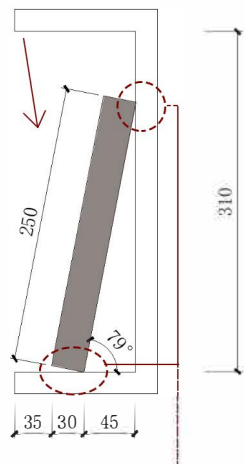

挂画侧着靠，
连接柜体处打胶处理

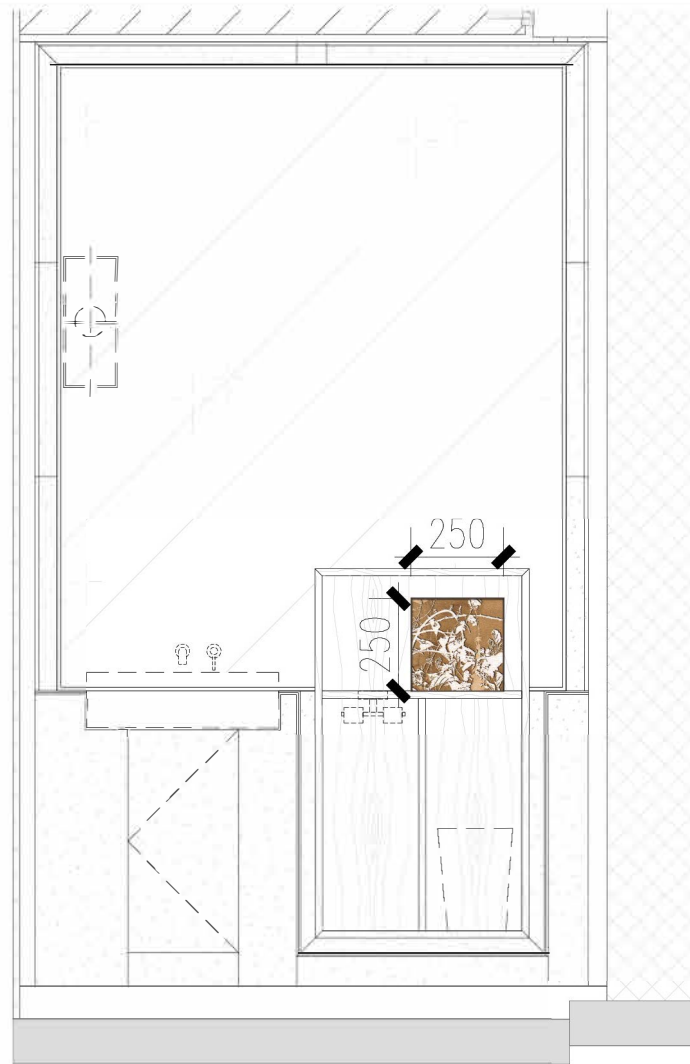

Furnishing articles and sculpture process requirements

摆件及雕塑工艺要求

- 1、 Art as the main theme, style, the main form of expression, need to have a strong visual impact
艺术品作为主题思想、风格的主要表现形式，需要具有很强的视觉冲击力。
- 2、 First, the designer confirmed the design, selected processing materials.
首先草图，效果图由设计师确认，选定加工材料。
- 3、 According to the site, to determine the size of the sculpture.
根据现场，图纸确定雕塑、摆件大小尺寸。
- 4、 Make mud draft, foam model, confirm the overall effect.
制作泥稿、泡沫模型，确认整体效果。
- 5、 Indoor metal art material thickness shall not be less than 1.5 mm, resin thickness shall not be less than 3mm.
金属艺术品材料厚度室内不得低于1.5mm,树脂厚度不得低于3mm。
树脂艺术品表面颜色保证不褪色。
- 6、 Resin artwork surface color guarantee does not fade.
树脂艺术品表面颜色保证不褪色。
- 7、 Seamless metal joints, bending polished smooth.
金属接缝处无缝隙，折弯处打磨光滑。
- 8、 摆件雕塑必须牢固、稳定、安全、与灯光很好结合。
- 9、 石材基座必须做好加重加固，以防碰撞引起倒掉。
- 10、 落地安放艺术品要稳、安全。

灵感来源: 天目银杏

模型示意:



画框示意: 深棕色画框
面宽7mm, H:30mm.



注: 1、实际艺术品以中标单位现场核实具体尺寸数量再深化为准;
2、此点位需灯光照亮,需灯光顾问配合处理。

平面图



DD-1数量为: 120间, DK: 3间

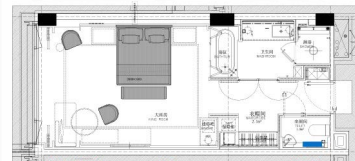

k-1数量为: 32间, K-1A: 10间

图片仅供参考,以最终效果为准。



K-2 客房效果图

K-2 ROOM RENDERING



K-2 客房洗手间效果图

K-2 GUEST ROOM RESTROOM RENDERING

Guestrooms K-2

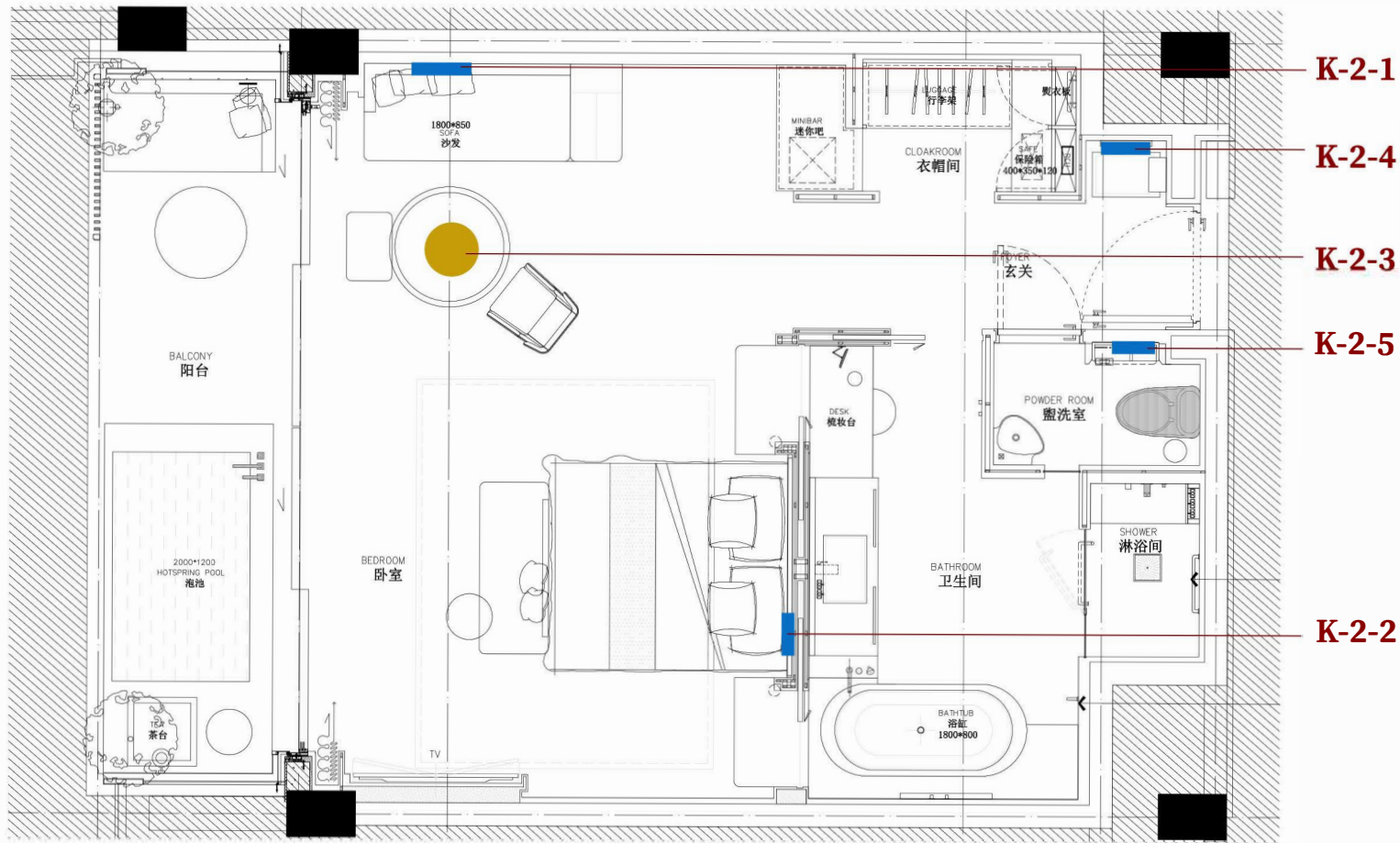

K-2客房

- 挂画  A级 
- 雕塑  B级 
- 摆件  C级 

注：所有艺术品点位位置需要灯光配合

K-3 Guestroom

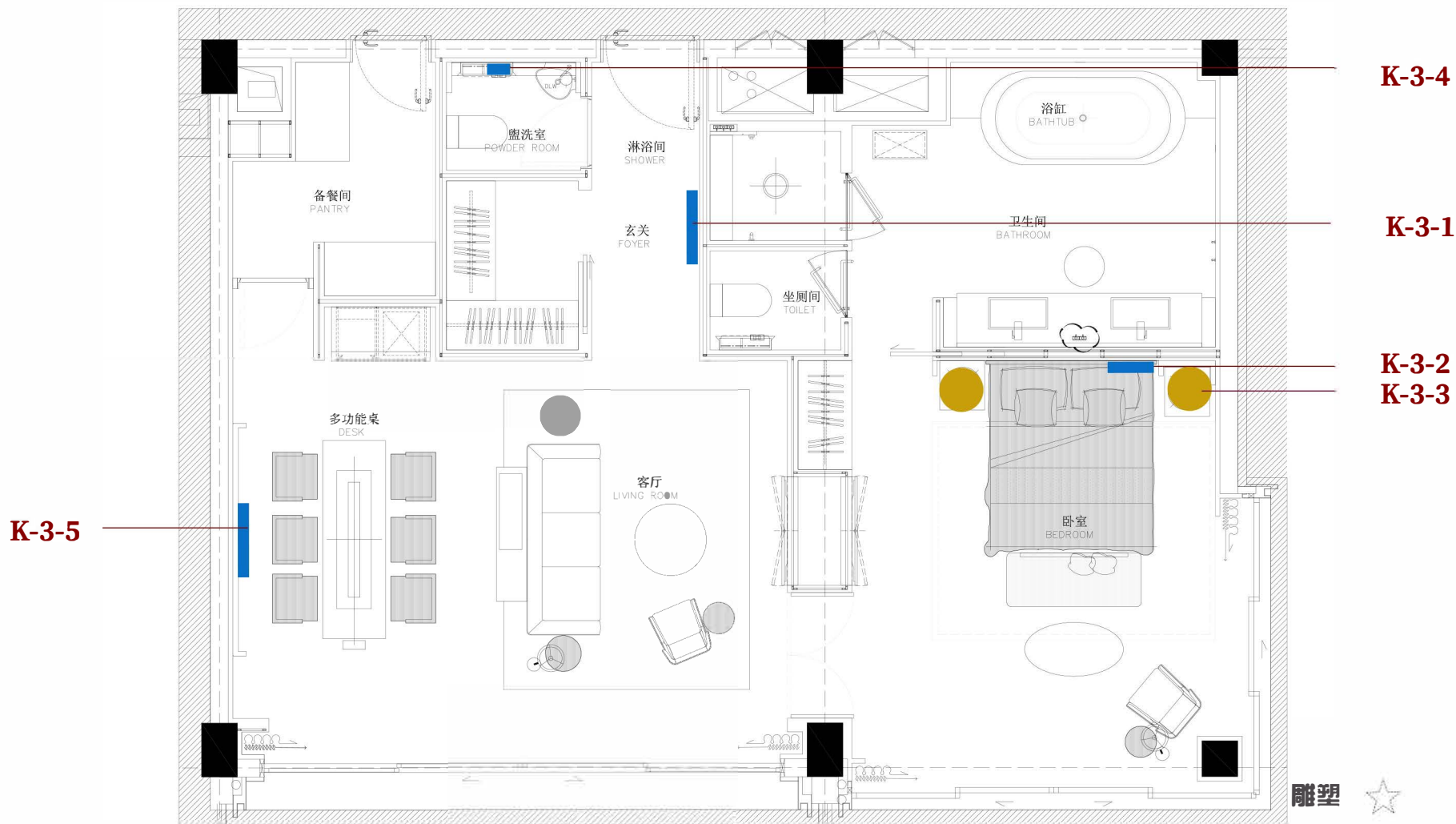

K-3 客房

- | | | | |
|----|---|----|---|
| 雕塑 | ☆ | A级 | ● |
| 挂画 | — | B级 | ● |
| 摆件 | ○ | C级 | ● |

注：所有艺术品点位位置需要灯光配合

柳杉主题

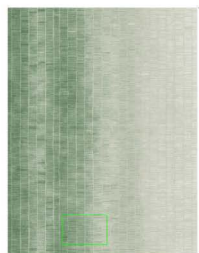
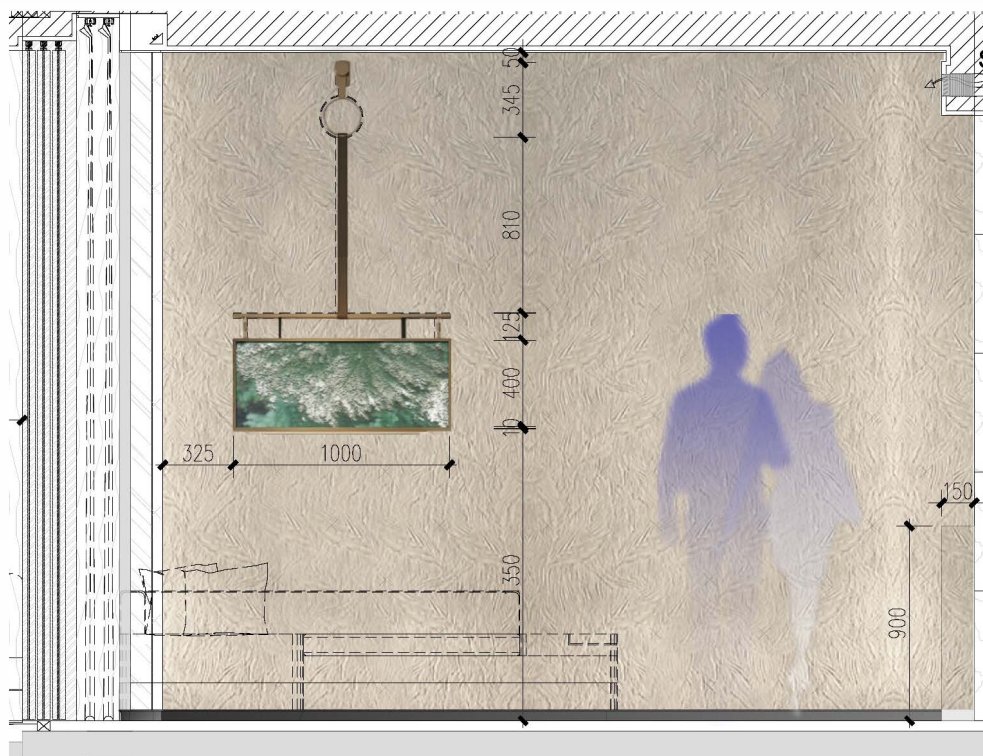
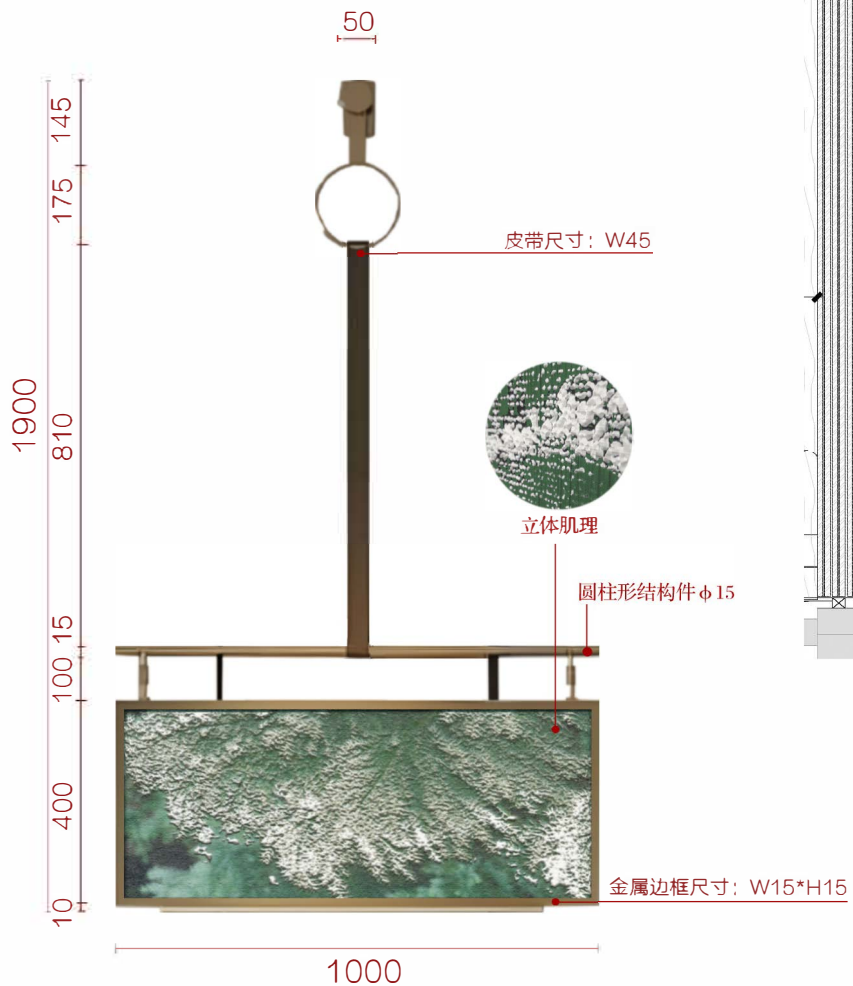

地毯颜色



提取柳杉元素

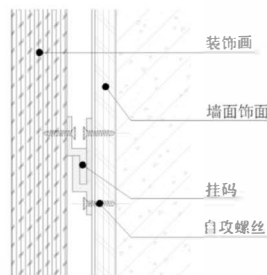

注: 1、实际艺术品以中标单位现场核实具体尺寸数量再深化为准;
2、此点位需灯光照亮, 需灯光顾问配合处理。

Furnishing articles and sculpture process requirements

摆件及雕塑工艺要求

- 1、 Art as the main theme, style, the main form of expression, need to have a strong visual impact
艺术品作为主题思想、风格的主要表现形式, 需要具有很强的视觉冲击力。
- 2、 First, the designer confirmed the design, selected processing materials.
首先草图, 效果图由设计师确认, 选定加工材料。
- 3、 According to the site, to determine the size of the sculpture.
根据现场, 图纸确定雕塑、摆件大小尺寸。
- 4、 Make mud draft, foam model, confirm the overall effect.
制作泥稿、泡沫模型, 确认整体效果。
- 5、 Indoor metal art material thickness shall not be less than 1.5 mm, resin thickness shall not be less than 3mm.
金属艺术品材料厚度室内不得低于1.5mm, 树脂厚度不得低于3mm。
- 6、 Resin artwork surface color guarantee does not fade.
树脂艺术品表面颜色保证不褪色。
- 7、 Seamless metal joints, bending polished smooth.
金属接缝处无缝隙, 折弯处打磨光滑。
- 8、 摆件雕塑必须牢固、稳定、安全、与灯光很好结合。
- 9、 石材基座必须做好加重加固, 以防碰撞引起倒掉。
- 10、 落地安放艺术品要稳、安全。

平面图

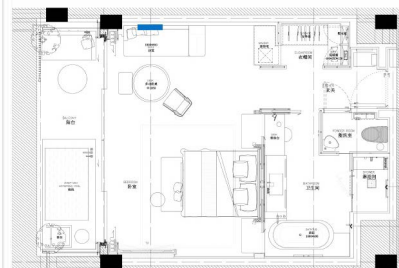

k-2数量为: 98间, K-2A: 4间
图片仅供参考, 以最终效果为准。

Project 项目名称: 杭州天目山格芮精选希尔顿酒店 Serial number 项目编号: k-2-2、K-3-2

Material 材质: 立体肌理+肌理画布+白色卡纸+深棕色木框

Process description 工艺说明:

Area 区域: 客房

Number 数量: 104组(每组两件)

Size 尺寸: W350*D30*H350,W700*D30*H350

画芯厚度3mm



立体肌理

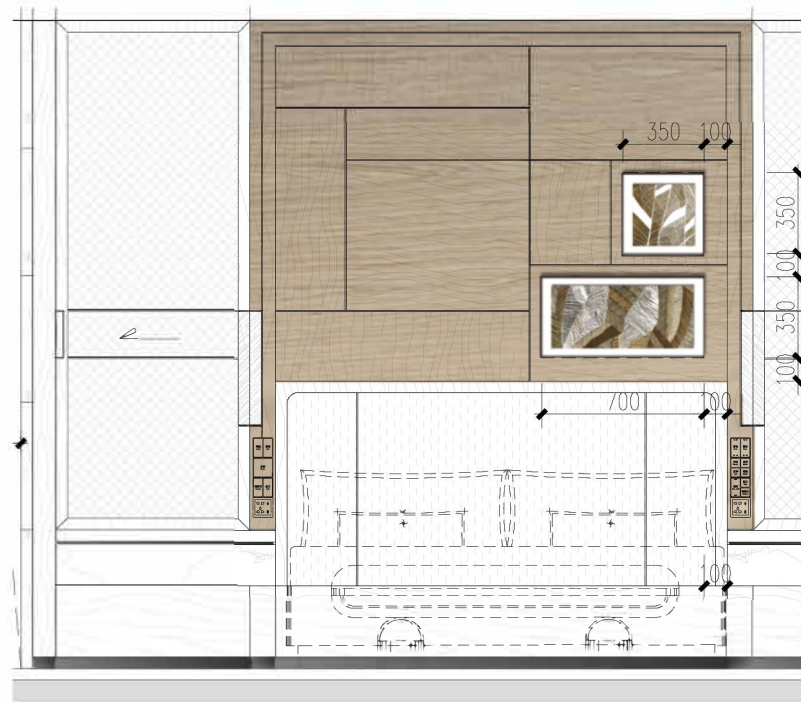
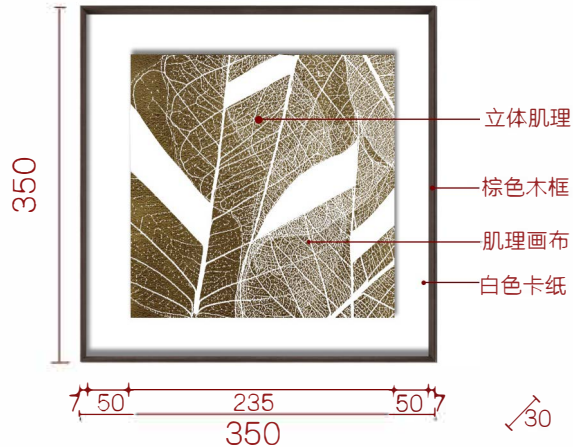

安装示意

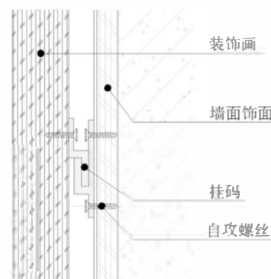

灵感来源: 树叶纹理



Furnishing articles and sculpture process requirements

摆件及雕塑工艺要求

- 1、Art as the main theme, style, the main form of expression, need to have a strong visual impact
艺术品作为主题思想、风格的主要表现形式, 需要具有很强的视觉冲击力。
- 2、First, the designer confirmed the design, selected processing materials.
首先草图, 效果图由设计师确认, 选定加工材料。
- 3、According to the site, to determine the size of the sculpture. 根据现场, 图纸确定雕塑、摆件大小尺寸。
- 4、Make mud draft, foam model, confirm the overall effect. 制作泥稿、泡沫模型, 确认整体效果。
- 5、Indoor metal art material thickness shall not be less than 1.5 mm, resin thickness shall not be less than 3mm.
金属艺术品材料壁厚室内不得低于1.5mm, 树脂壁厚不得低于3mm。
- 6、Resin artwork surface color guarantee does not fade. 树脂艺术品表面颜色保证不褪色。
- 7、Seamless metal joints, bending polished smooth. 金属接缝处无缝隙, 折弯处打磨光滑。
- 8、摆件雕塑必须牢固、稳定、安全、与灯光很好结合。
- 9、石材基座必须做好加重加固, 以防碰撞引起倒掉。
- 10、落地安放艺术品要稳、安全。

平面图



k-2数量为: 98间, K-2A: 4间



K-3房型数量: 2组

图片仅供参考, 以最终效果为准。

天目山国家级自然保护区, 保有多种多样的绿色自然种群, 以森林树叶的独特叶脉纹理展现艺术挂画, 感觉大自然的美妙。

注: 1、实际艺术品以中标单位现场核实具体尺寸数量再深化为准; 2、此点位需灯光照亮, 需灯光顾问配合处理。

Project 项目名称: 杭州天目山格芮精选希尔顿酒店 Serial number 项目编号: K-2-3、K-3-3

Area 区域: 客房 Number 数量: 104组(每组两件)

Material 材质: 真书书籍

Size 尺寸: 成品尺寸书籍

Process description 工艺说明:



书籍选型: (有关天目山动植物或英文绿植花艺等书籍)

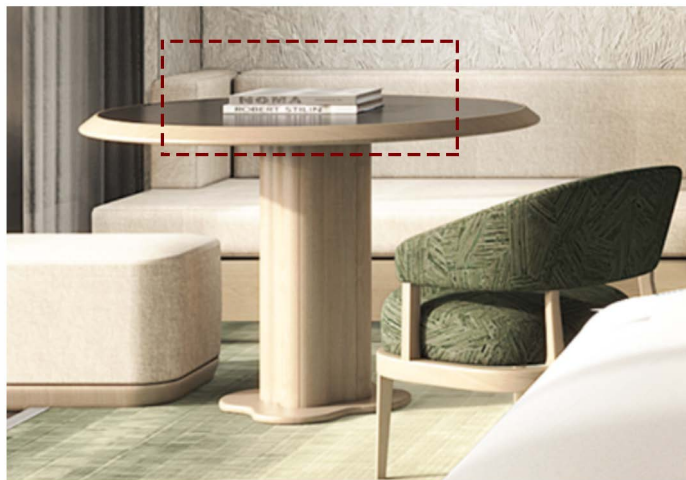

Furnishing articles and sculpture process requirements

摆件及雕塑工艺要求

1、 Art as the main theme, style, the main form of expression, need to have a strong visual impact

艺术品作为主题思想、风格的主要表现形式, 需要具有很强的视觉冲击力。

2、 First, the designer confirmed the design, selected processing materials.

首先草图, 效果图由设计师确认, 选定加工材料。

3、 According to the site, to determine the size of the sculpture. 根据现场, 图纸确定雕塑、摆件大小尺寸。

4、 Make mud draft, foam model, confirm the overall effect. 制作泥稿、泡沫模型, 确认整体效果。

5、 Indoor metal art material thickness shall not be less than 1.5 mm, resin thickness shall not be less than 3mm.

金属艺术品材料厚度室内不得低于1.5mm,树脂厚度不得低于3mm。

6、 Resin artwork surface color guarantee does not fade. 树脂艺术品表面颜色保证不褪色。

7、 Seamless metal joints, bending polished smooth. 金属接缝处无缝隙, 折弯处打磨光滑。

8、 摆件雕塑必须牢固、稳定、安全、与灯光很好结合。

9、 石材基座必须做好加重加固, 以防碰撞引起倒塌。

10、落地安放艺术品要稳、安全。

平面图

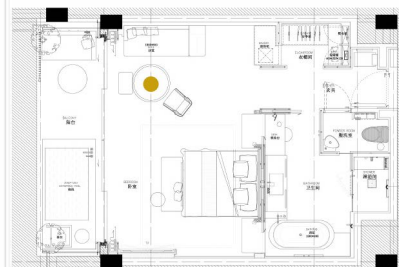

k-2数量为: 98间, K-2A: 4间
K-3: 2间
每间2本。

图片仅供参考, 以最终效果为准。

注: 1、实际艺术品以中标单位现场核实具体尺寸数量再深化为准;

Project 项目名称: 杭州天目山格芮精选希尔顿酒店 Serial number 项目编号: K-2-4

Material 材质: 立体肌理+喷绘画面+金属画框

Process description 工艺说明:

Area 区域: 客房

Number 数量: 102件

Size 尺寸: W400*D30*H600

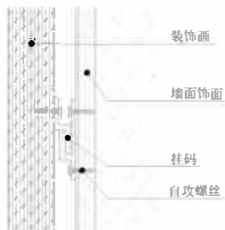
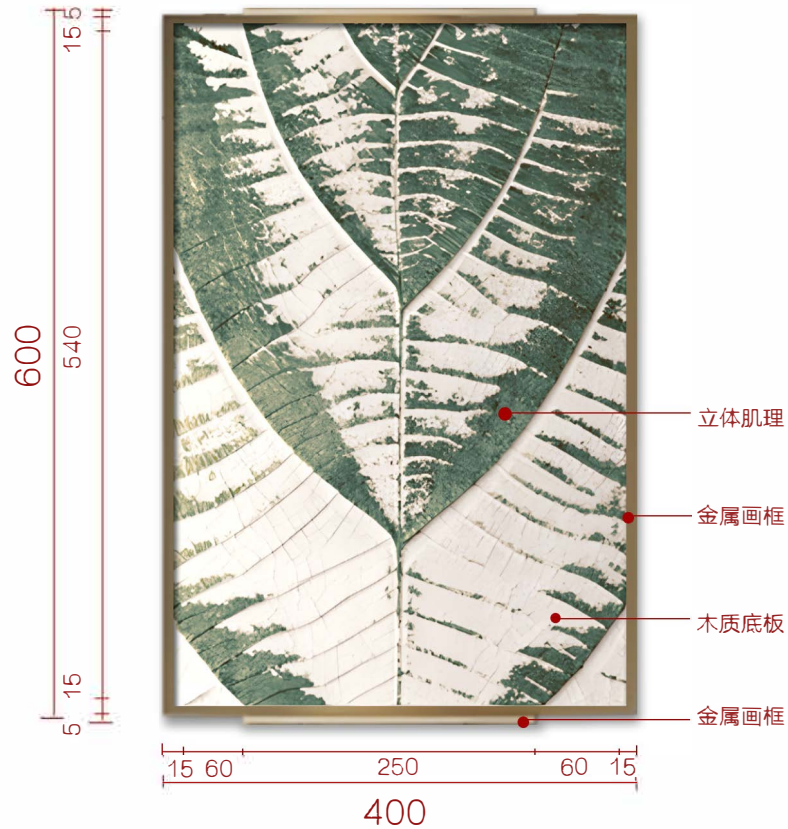

设计元素: 叶脉肌理



材质细节: 立体肌理

Furnishing articles and sculpture process requirements

摆件及雕塑工艺要求

- 1、Art as the main theme, style, the main form of expression, need to have a strong visual impact
艺术品作为主题思想、风格的主要表现形式, 需要具有很强的视觉冲击力。
- 2、First, the designer confirmed the design, selected processing materials.
首先草图, 效果图由设计师确认, 选定加工材料。
- 3、According to the site, to determine the size of the sculpture.
根据现场, 图纸确定雕塑、摆件大小尺寸。
- 4、Make mud draft, foam model, confirm the overall effect.
制作泥稿、泡沫模型, 确认整体效果。
- 5、Indoor metal art material thickness shall not be less than 1.5 mm, resin thickness shall not be less than 3mm.
金属艺术品材料厚度室内不得低于1.5mm, 树脂厚度不得低于3mm。
- 6、Resin artwork surface color guarantee does not fade.
树脂艺术品表面颜色保证不褪色。
- 7、Seamless metal joints, bending polished smooth.
金属接缝处无缝隙, 折弯处打磨光滑。
- 8、摆件雕塑必须牢固、稳定、安全、与灯光很好结合。
- 9、石材基座必须做好加重加固, 以防碰撞引起倒塌。
- 10、落地安放艺术品要稳、安全。

平面图

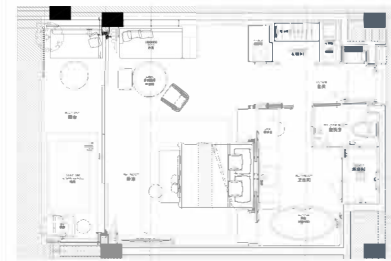

注: 1、实际艺术品以中标单位现场核实具体尺寸数量再深化为准;
2、此点位需灯光照亮, 需灯光顾问配合处理。

k-2数量为: 98间, K-2A: 4间
图片仅供参考, 以最终效果为准。

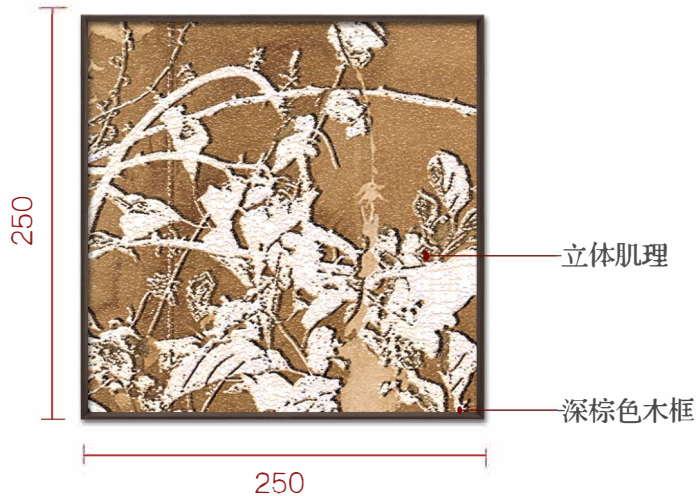

建议灯光从上往下打光。

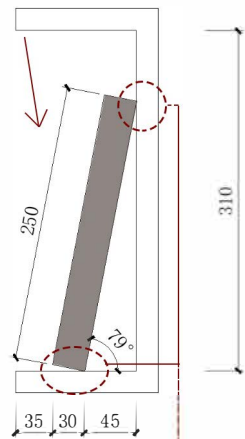

挂画侧着靠, 连接柜体处打胶处理

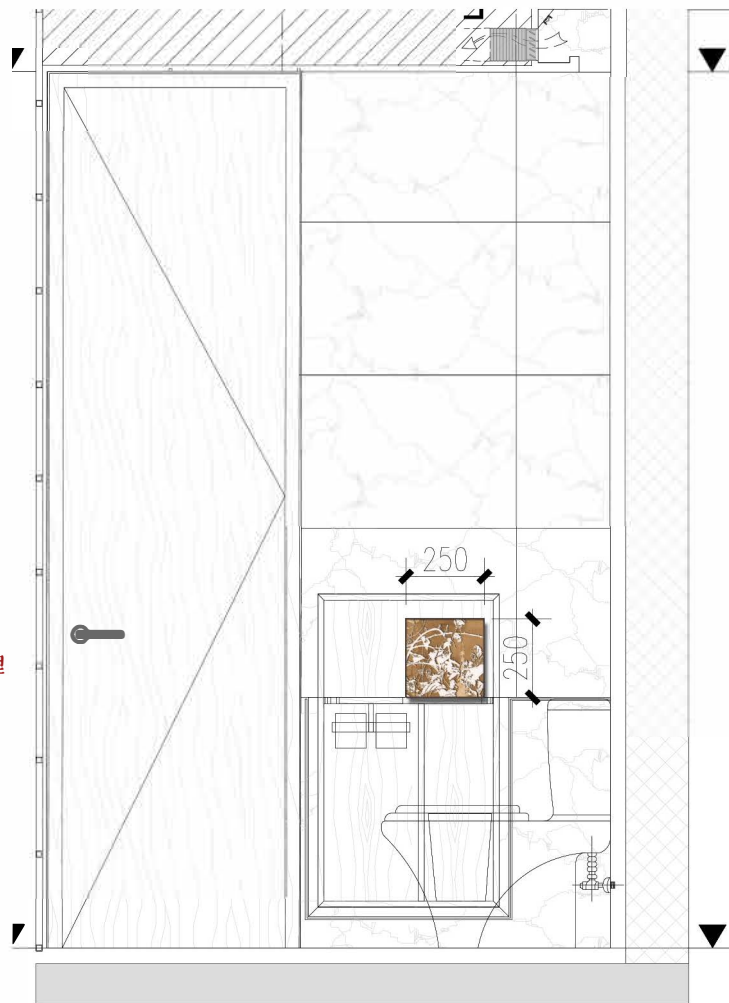

Furnishing articles and sculpture process requirements

摆件及雕塑工艺要求

- 1、Art as the main theme, style, the main form of expression, need to have a strong visual impact
艺术品作为主题思想、风格的主要表现形式, 需要具有很强的视觉冲击力。
- 2、First, the designer confirmed the design, selected processing materials.
首先草图, 效果图由设计师确认, 选定加工材料。
- 3、According to the site, to determine the size of the sculpture.
根据现场, 图纸确定雕塑、摆件大小尺寸。
- 4、Make mud draft, foam model, confirm the overall effect.
制作泥稿、泡沫模型, 确认整体效果。
- 5、Indoor metal art material thickness shall not be less than 1.5 mm, resin thickness shall not be less than 3mm.
金属艺术品材料厚度室内不得低于1.5mm, 树脂厚度不得低于3mm。
- 6、Resin artwork surface color guarantee does not fade.
树脂艺术品表面颜色保证不褪色。
- 7、Seamless metal joints, bending polished smooth.
金属接缝处无缝隙, 折弯处打磨光滑。
- 8、摆件雕塑必须牢固、稳定、安全、与灯光很好结合。
- 9、石材基座必须做好加重加固, 以防碰撞引起倒掉。
- 10、落地安放艺术品要稳、安全。

灵感来源: 天目银杏



模型示意:

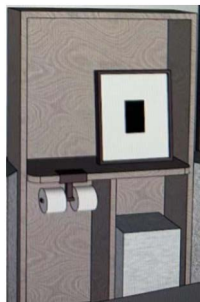

画框示意: 深棕色画框
面宽7mm, H:30mm。



注: 1、实际艺术品以中标单位现场核实具体尺寸数量再深化为准;
2、此点位需灯光照亮, 需灯光顾问配合处理。

平面图



K-2房型数量: 98件
K-2A房型数量: 4件



K-3房型数量: 2件
图片仅供参考, 以最终效果为准。

Project 项目名称: 杭州天目山格芮精选希尔顿酒店 Serial number 项目编号: K-3-1

Area 区域: 客房

Number 数量: 2件

Material 材质: 立体肌理+肌理画布+无框直裱

Size 尺寸: W1100*H1100

Process description 工艺说明:



天目铁木主题

抽象运用叶脉的纹理，立体肌理的形式表现出树叶律动。

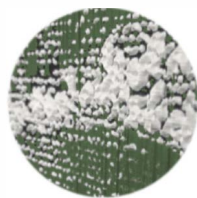
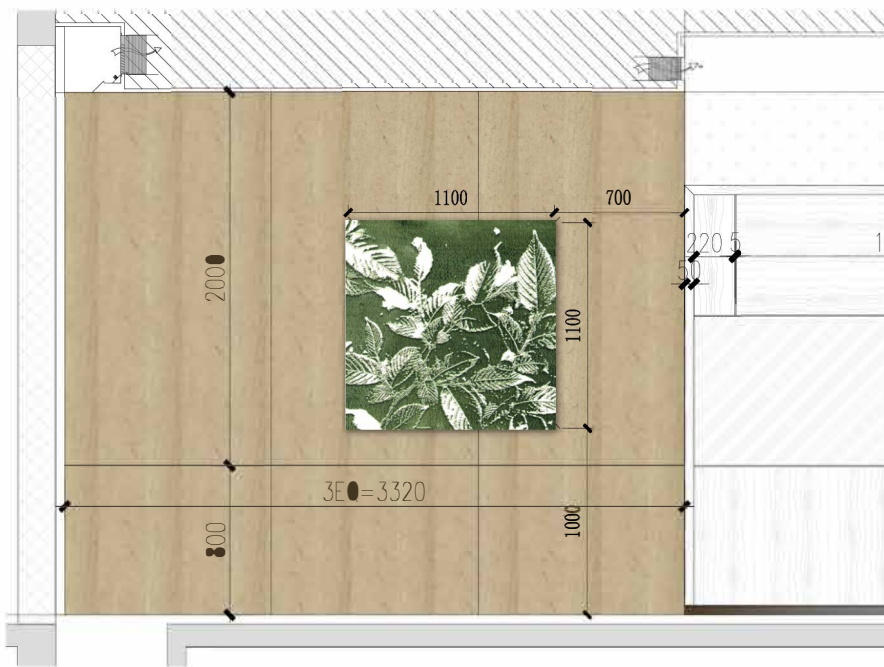

立体肌理



提取天目铁木元素

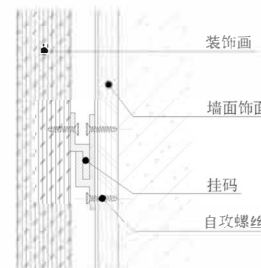

注: 1、实际艺术品以中标单位现场核实具体尺寸数量再深化为准;
2、此点位需灯光照亮, 需灯光顾问配合处理。

Furnishing articles and sculpture process requirements

摆件及雕塑工艺要求

- 1、Art as the main theme, style, the main form of expression, need to have a strong visual impact
艺术品作为主题思想、风格的主要表现形式, 需要具有很强的视觉冲击力。
- 2、First, the designer confirmed the design, selected processing materials.
首先草图, 效果图由设计师确认, 选定加工材料。
- 3、According to the site, to determine the size of the sculpture.
根据现场, 图纸确定雕塑、摆件大小尺寸。
- 4、Make mud draft, foam model, confirm the overall effect.
制作泥稿、泡沫模型, 确认整体效果。
- 5、Indoor metal art material thickness shall not be less than 1.5 mm, resin thickness shall not be less than 3mm.
金属艺术品材料厚度室内不得低于1.5mm, 树脂厚度不得低于3mm。
- 6、Resin artwork surface color guarantee does not fade.
树脂艺术品表面颜色保证不褪色。
- 7、Seamless metal joints, bending polished smooth.
金属接缝处无缝隙, 折弯处打磨光滑。
- 8、摆件雕塑必须牢固、稳定、安全、与灯光很好结合。
- 9、石材基座必须做好加重加固, 以防碰撞引起倒塌。
- 10、落地安放艺术品要稳、安全。

平面图

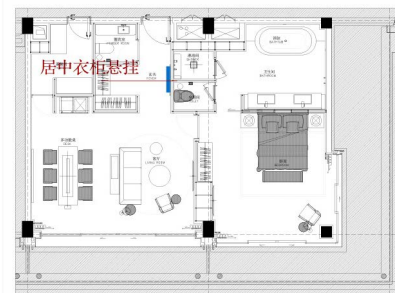

图片仅供参考, 以最终效果为准。

Project 项目名称: 杭州天目山格芮精选希尔顿酒店 Serial number 项目编号: K-3-5

Material 材质: 立体肌理+肌理画布+白色底板+深棕色木框

Process description 工艺说明:

Area 区域: 客房

Number 数量: 2件

Size 尺寸: W350*D30*H350,W700*D30*H350

画芯厚度3mm



立体肌理

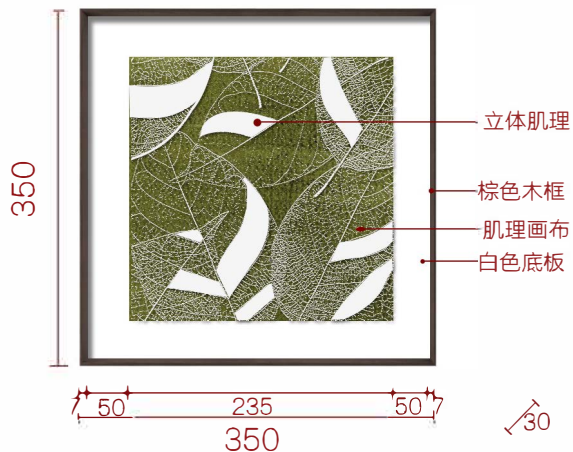

安装示意

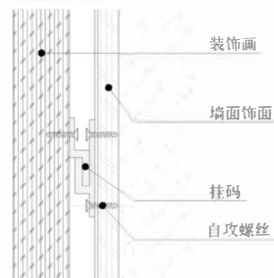

灵感来源: 天目铁木



Furnishing articles and sculpture process requirements

摆件及雕塑工艺要求

- 1、Art as the main theme, style, the main form of expression, need to have a strong visual impact
艺术品作为主题思想、风格的主要表现形式, 需要具有很强的视觉冲击力。
- 2、First, the designer confirmed the design, selected processing materials.
首先草图, 效果图由设计师确认, 选定加工材料。
- 3、According to the site, to determine the size of the sculpture.
根据现场, 图纸确定雕塑、摆件大小尺寸。
- 4、Make mud draft, foam model, confirm the overall effect.
制作泥稿、泡沫模型, 确认整体效果。
- 5、Indoor metal art material thickness shall not be less than 1.5 mm, resin thickness shall not be less than 3mm.
金属艺术品材料厚度室内不得低于1.5mm, 树脂厚度不得低于3mm。
- 6、Resin artwork surface color guarantee does not fade.
树脂艺术品表面颜色保证不褪色。
- 7、Seamless metal joints, bending polished smooth.
金属接缝处无缝隙, 折弯处打磨光滑。
- 8、摆件雕塑必须牢固、稳定、安全、与灯光很好结合。
- 9、石材基座必须做好加重加固, 以防碰撞引起倒塌。
- 10、落地安放艺术品要稳、安全。

平面图

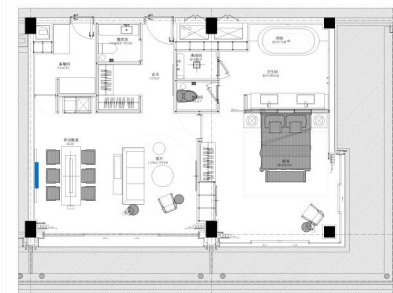

图片仅供参考, 以最终效果为准。

注: 1、实际艺术品以中标单位现场核实具体尺寸数量再深化为准;
2、此点位需灯光照亮, 需灯光顾问配合处理。

以天目铁木树叶团簇以及飘散的黄色叶子为主题的挂画, 仿佛是自然风景的写照, 取了一处景色框写在客房中, 能够感受大自然的美妙。

2BS-1 Guest Room

2BS-1 客房

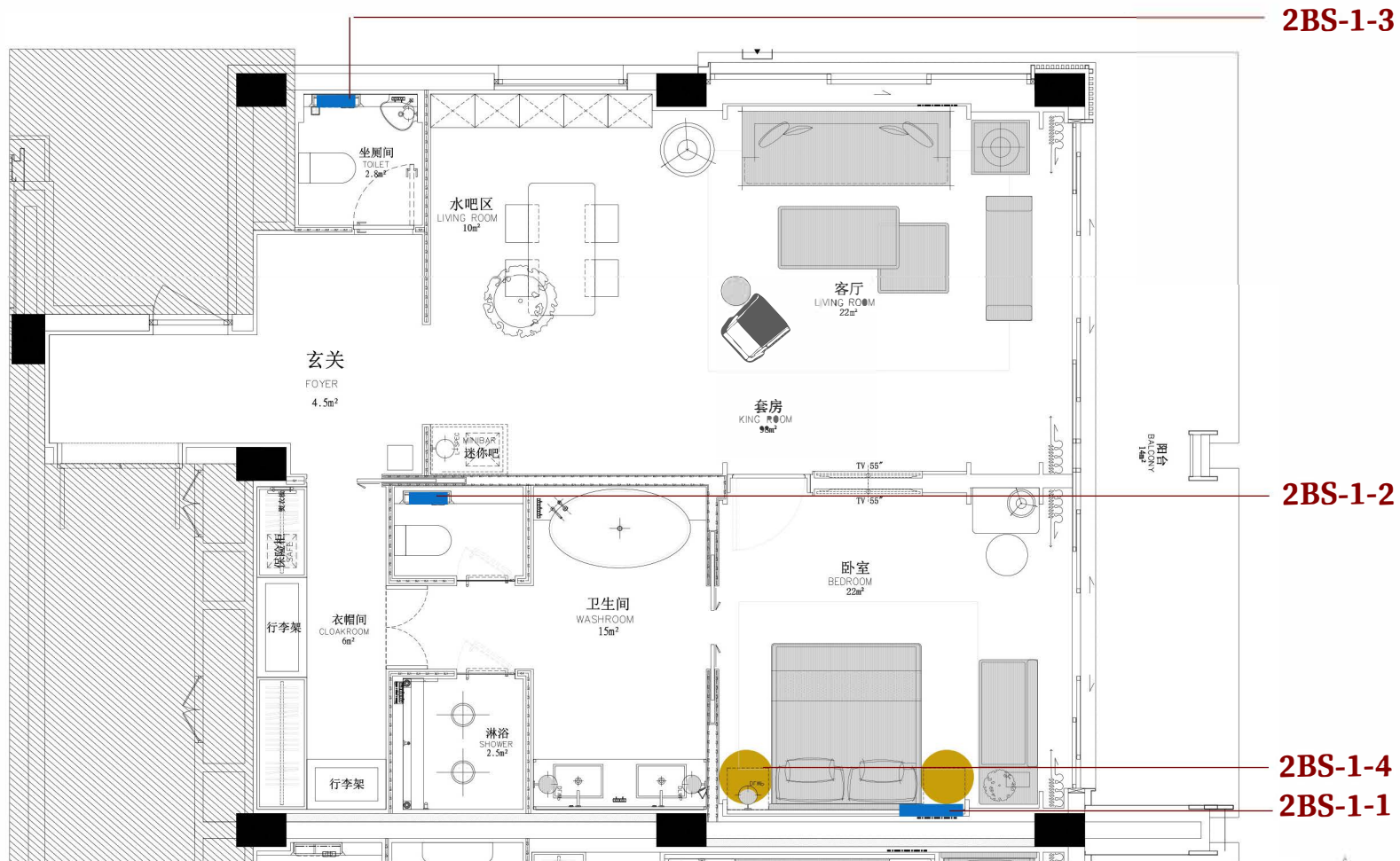

- | | | | |
|----|---|----|---|
| 雕塑 | ☆ | A级 | ● |
| 挂画 | ▭ | B级 | ● |
| 摆件 | ○ | C级 | ● |

注：所有艺术品点位位置需要灯光配合

2BS-2 Guest Room



2BS-2 客房

- | | | | |
|----|---|----|---|
| 雕塑 | ☆ | A级 | ● |
| 挂画 | ▭ | B级 | ● |
| 摆件 | ○ | C级 | ● |

注：所有艺术品点位位置需要灯光配合

2BS-3 Guest Room

2BS-3 客房

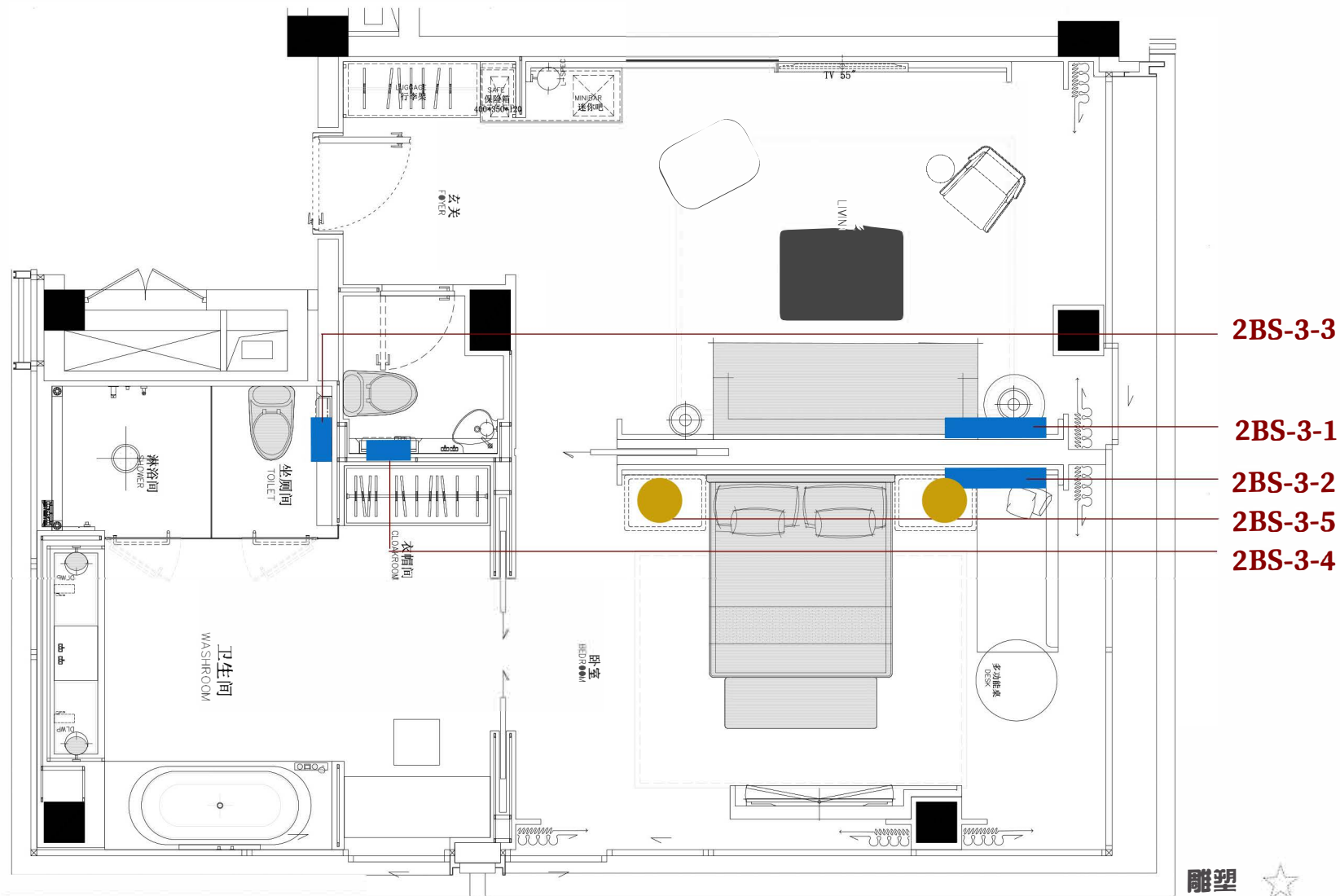

- | | | | |
|----|---|----|---|
| 雕塑 | ☆ | A级 | ● |
| 挂画 | ▭ | B级 | ● |
| 摆件 | ○ | C级 | ● |

注：所有艺术品点位位置需要灯光配合

GM Guest Room Plan

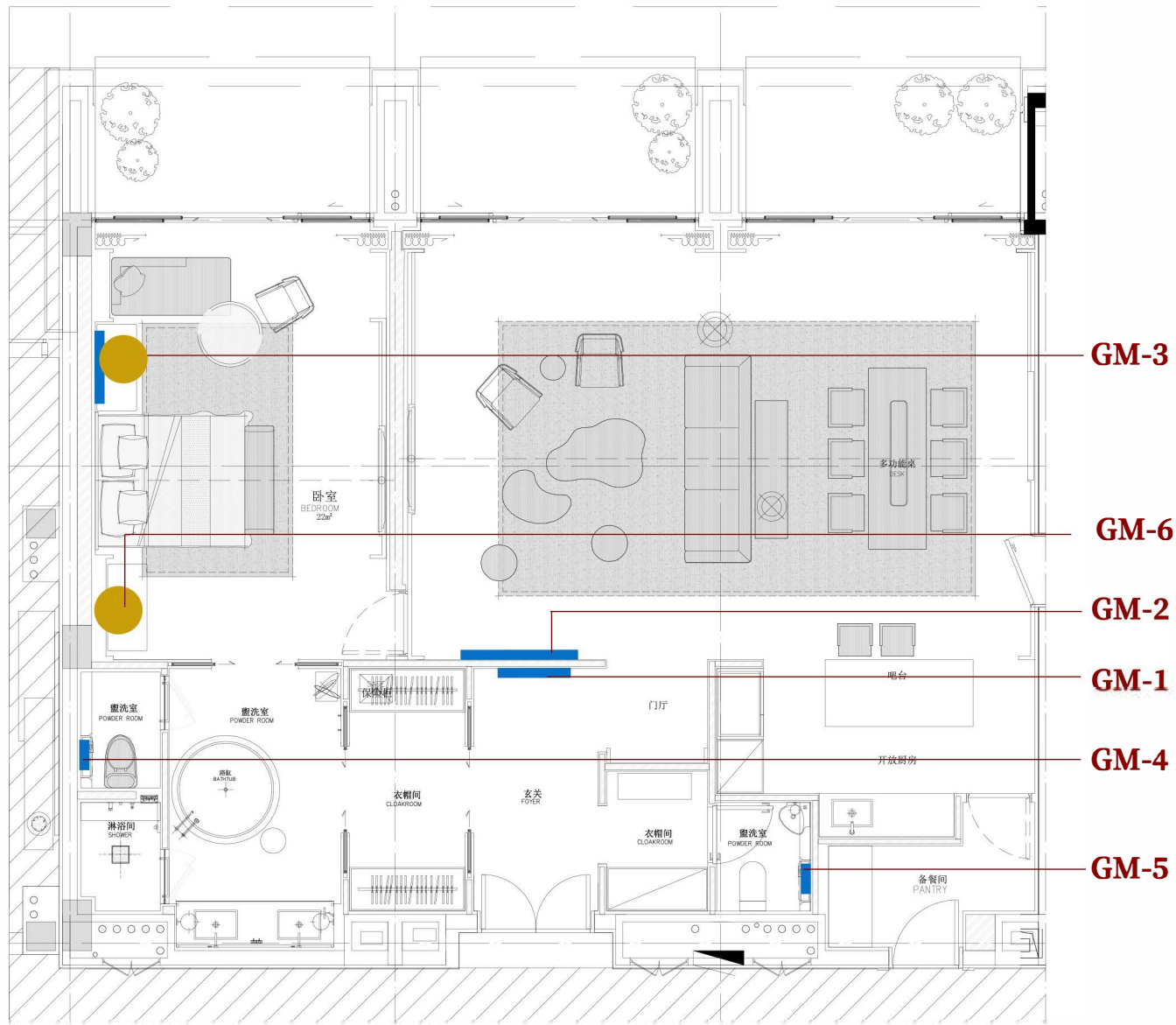

GM客房平面图

注：所有艺术品点位位置需要灯光配合

Project 项目名称: 杭州天目山格芮精选希尔顿酒店 Serial number 项目编号: 2BS-3-1

Material 材质: 立体肌理+肌理画布+白色卡纸+深棕色木框

Process description 工艺说明:

Area 区域: 客房

Number 数量: 1组(每组两件)

Size 尺寸: W350*D30*H350,W700*D30*H350

画芯厚度3mm



立体肌理

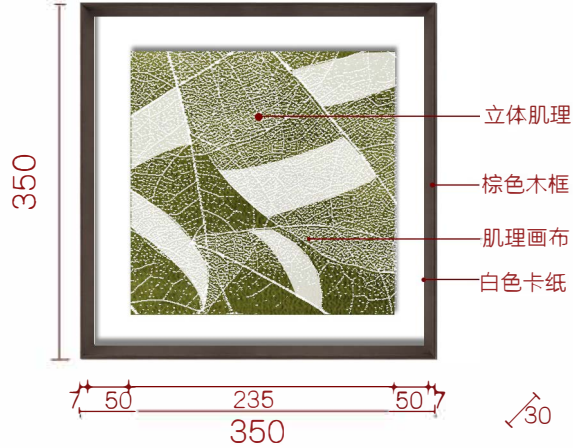

安装示意

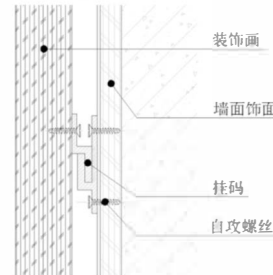

灵感来源: 树叶纹理



Furnishing articles and sculpture process requirements

摆件及雕塑工艺要求

- 1、Art as the main theme, style, the main form of expression, need to have a strong visual impact
艺术品作为主题思想、风格的主要表现形式, 需要具有很强的视觉冲击力。
- 2、First, the designer confirmed the design, selected processing materials.
首先草图, 效果图由设计师确认, 选定加工材料。
- 3、According to the site, to determine the size of the sculpture. 根据现场, 图纸确定雕塑、摆件大小尺寸。
- 4、Make mud draft, foam model, confirm the overall effect. 制作泥稿、泡沫模型, 确认整体效果。
- 5、Indoor metal art material thickness shall not be less than 1.5 mm, resin thickness shall not be less than 3mm.
金属艺术品材料壁厚室内不得低于1.5mm,树脂壁厚不得低于3mm。
- 6、Resin artwork surface color guarantee does not fade. 树脂艺术品表面颜色保证不褪色。
- 7、Seamless metal joints, bending polished smooth. 金属接缝处无缝隙, 折弯处打磨光滑。
- 8、摆件雕塑必须牢固、稳定、安全、与灯光很好结合。
- 9、石材基座必须做好加重加固, 以防碰撞引起倒掉。
- 10、落地安放艺术品要稳、安全。

平面图

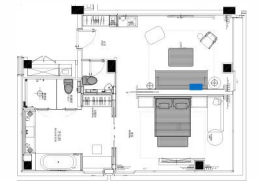

2BS-3房型数量: 1件

天目山国家级自然保护区, 保有多种多样的绿色自然种群, 以森林树叶的独特叶脉纹理展现艺术挂画, 感觉大自然的美妙。

注: 1、实际艺术品以中标单位现场核实具体尺寸数量再深化为准;
2、此点位需灯光照亮, 需灯光顾问配合处理。

图片仅供参考, 以最终效果为准。

Project 项目名称: 杭州天目山格芮精选希尔顿酒店 Serial number 项目编号: 2BS-1-1、2BS-2-2、2BS-3-2、GM-3
 Area 区域: 客房 Number 数量: 22组(每组两件)

Material 材质: 立体肌理+肌理画布+白色卡纸+深棕色木框
 Size 尺寸: W350*D30*H350,W700*D30*H350

Process description 工艺说明:

画芯厚度3mm



立体肌理

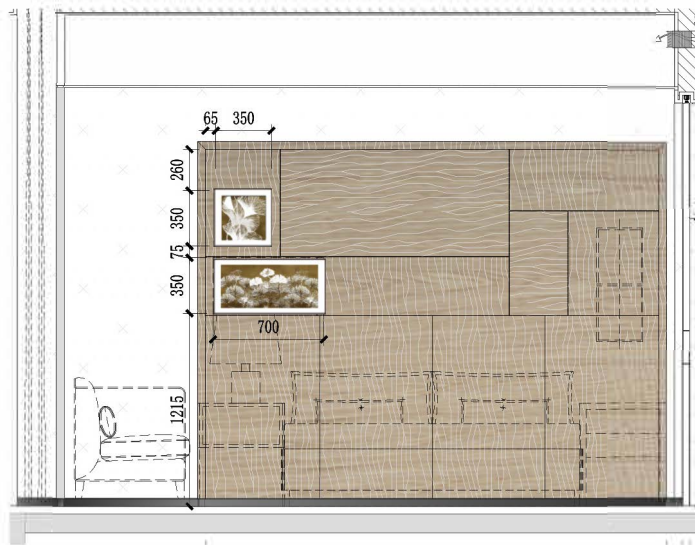
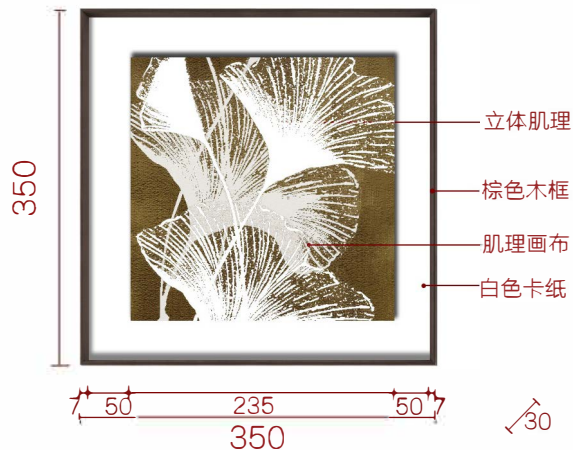

安装示意

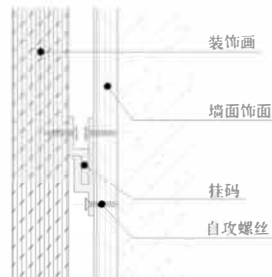

灵感来源: 银杏叶



Furnishing articles and sculpture process requirements

摆件及雕塑工艺要求

- 1、 Art as the main theme, style, the main form of expression, need to have a strong visual impact
 艺术品作为主题思想、风格的主要表现形式, 需要具有很强的视觉冲击力。
- 2、 First, the designer confirmed the design, selected processing materials.
 首先草图, 效果图由设计师确认, 选定加工材料。
- 3、 According to the site, to determine the size of the sculpture.
 根据现场, 图纸确定雕塑、摆件大小尺寸。
- 4、 Make mud draft, foam model, confirm the overall effect.
 制作泥稿、泡沫模型, 确认整体效果。
- 5、 Indoor metal art material thickness shall not be less than 1.5 mm, resin thickness shall not be less than 3mm.
 金属艺术品材料厚度室内不得低于1.5mm, 树脂艺术品厚度不得低于3mm。
- 6、 Resin artwork surface color guarantee does not fade.
 树脂艺术品表面颜色保证不褪色。
- 7、 Seamless metal joints, bending polished smooth.
 金属接缝处无缝隙, 折弯处打磨光滑。
- 8、 摆件雕塑必须牢固、稳定、安全、与灯光很好结合。
- 9、 石材基座必须做好加固, 以防碰撞引起倒塌。
- 10、 落地安放艺术品要稳、安全。

平面图



2BS-1房型数量: 17件
 2BS-2房型数量: 3件
 2BS-3房型数量: 1件
 GM房型数量: 1件

图片仅供参考, 以最终效果为准。

天目山国家级自然保护区, 保有多多种多样的绿色自然种群, 以森林树叶的独特叶脉纹理展现艺术挂画, 感觉大自然的美妙。

注: 1、实际艺术品以中标单位现场核实具体尺寸数量再深化为准;
 2、此点位需灯光照亮, 需灯光顾问配合处理。

Project 项目名称: 杭州天目山格芮精选希尔顿酒店 Serial number 项目编号: 2BS-2-1

Material 材质: 喷绘画面+卡纸+黑色木框+玻璃摆件

Process description 工艺说明:

Area 区域: 客房

Number 数量: 3组

Size 尺寸: 挂画: W450*H450,摆件: H350,H550

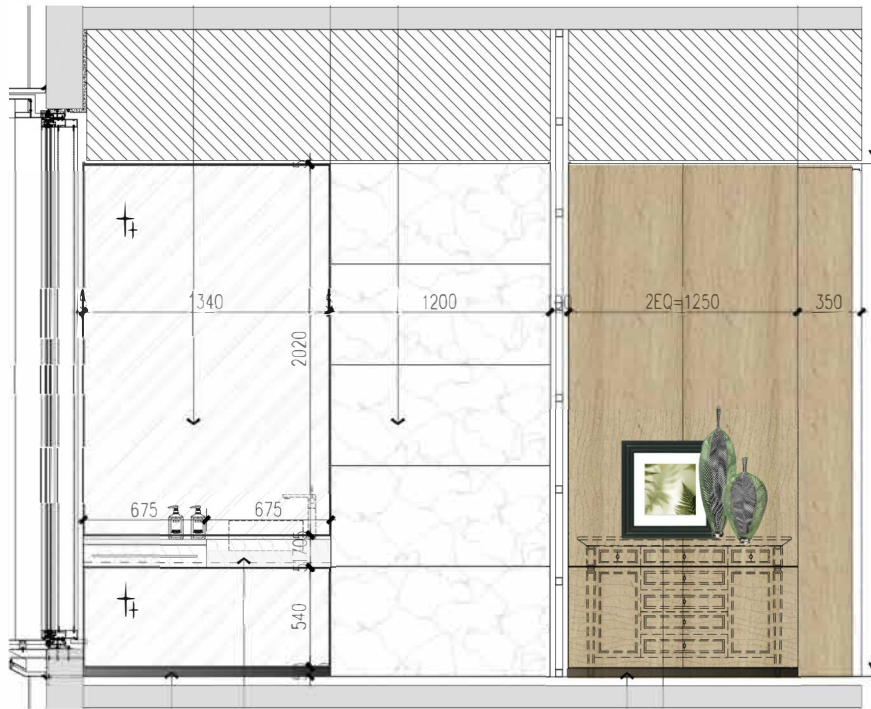

Furnishing articles and sculpture process requirements

摆件及雕塑工艺要求

1、 Art as the main theme, style, the main form of expression, need to have a strong visual impact

艺术品作为主题思想、风格的主要表现形式, 需要具有很强的视觉冲击力。

2、 First, the designer confirmed the design, selected processing materials

首先草图, 效果图由设计师确认, 选定加工材料。

3、 According to the site, to determine the size of the sculpture. 根据现场, 图纸确定雕塑、摆件大小尺寸。

4、 Make mud draft, foam model, confirm the overall effect. 制作泥稿、泡沫模型, 确认整体效果。

5、 Indoor metal art material thickness shall not be less than 1.5 mm, resin thickness shall not be less than 3mm. 金属艺术品材料厚度室内不得低于1.5mm,树脂壁厚不得低于3mm。

6、 Resin artwork surface color guarantee does not fade. 树脂艺术品表面颜色保证不褪色。

7、 Seamless metal joints, bending polished smooth. 金属接缝处无缝隙, 折弯处打磨光滑。

8、 摆件雕塑必须牢固、稳定、安全、与灯光很好结合。

9、 石材基座必须做好加重加固, 以防碰撞引起倒塌。

10、 落地安放艺术品要稳、安全。

平面图

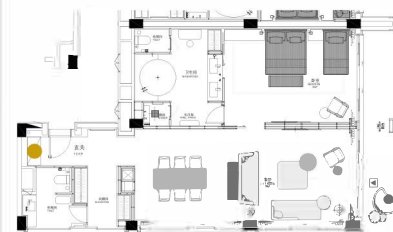

注: 1、实际艺术品以中标单位现场核实具体尺寸数量再深化为准;
2、此点位需灯光照亮, 需灯光顾问配合处理。

图片仅供参考, 以最终效果为准。

Project 项目名称: 杭州天目山格芮精选希尔顿酒店 Serial number 项目编号: 2BS-2-5

Material 材质: 喷绘画面+肌理效果+木地板+无框直裱

Process description 工艺说明:

Area 区域: 客房

Number 数量: 3组

Size 尺寸: W2200*H1200



叶脉镂空肌理效果

2200

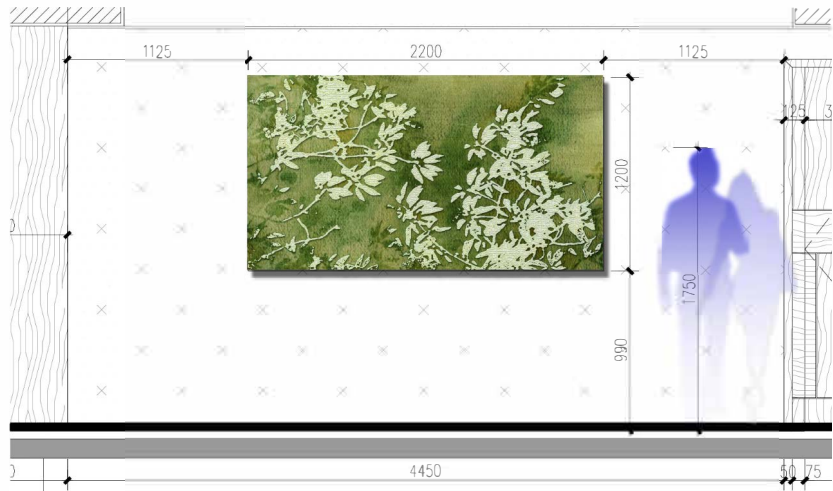

安装示意

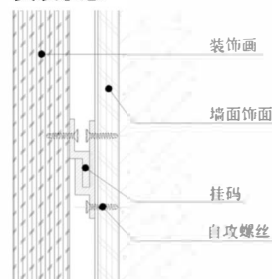

灵感来源: 天目铁木



Furnishing articles and sculpture process requirements

摆件及雕塑工艺要求

1、 Art as the main theme, style, the main form of expression, need to have a strong visual impact

艺术品作为主题思想、风格的主要表现形式, 需要具有很强的视觉冲击力。

2、 First, the designer confirmed the design, selected processing materials.

首先草图, 效果图由设计师确认, 选定加工材料。

3、 According to the site, to determine the size of the sculpture. 根据现场, 图纸确定雕塑、摆件大小尺寸。

4、 Make mud draft, foam model, confirm the overall effect. 制作泥稿、泡沫模型, 确认整体效果。

5、 Indoor metal art material thickness shall not be less than 1.5 mm, resin thickness shall not be less than 3mm.

金属艺术品材料壁厚室内不得低于1.5mm,树脂壁厚度不得低于3mm。

6、 Resin artwork surface color guarantee does not fade. 树脂艺术品表面颜色保证不褪色。

7、 Seamless metal joints, bending polished smooth. 金属接缝处无缝隙, 折弯处打磨光滑。

8、 摆件雕塑必须牢固、稳定、安全、与灯光很好结合。

9、 石材基座必须做好加重加固, 以防碰撞引起倒掉。

10、 落地安放艺术品要稳、安全。

平面图

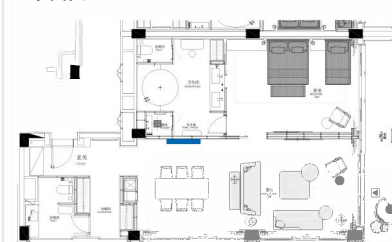

注: 1、实际艺术品以中标单位现场核实具体尺寸数量再深化为准;
2、此点位需灯光照亮, 需灯光顾问配合处理。

图片仅供参考, 以最终效果为准。

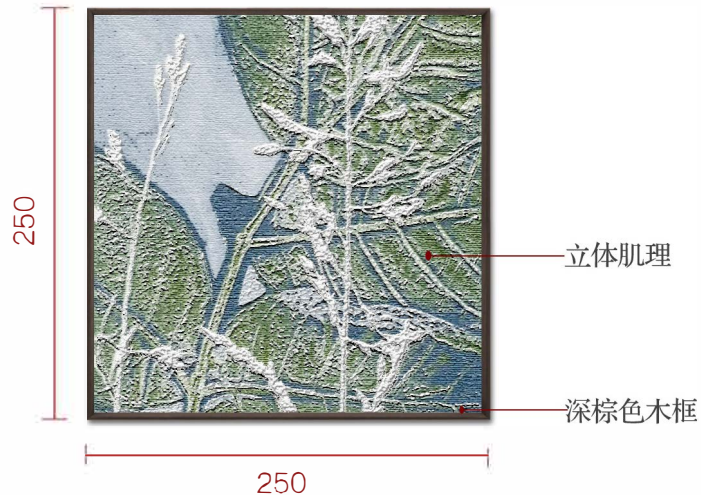

建议灯光从上往下打光。

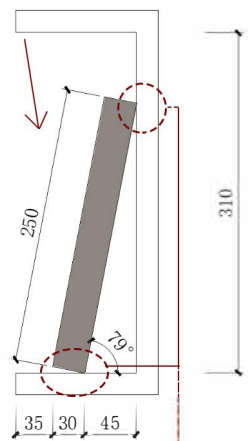

挂画侧着靠, 连接柜体处打胶处理

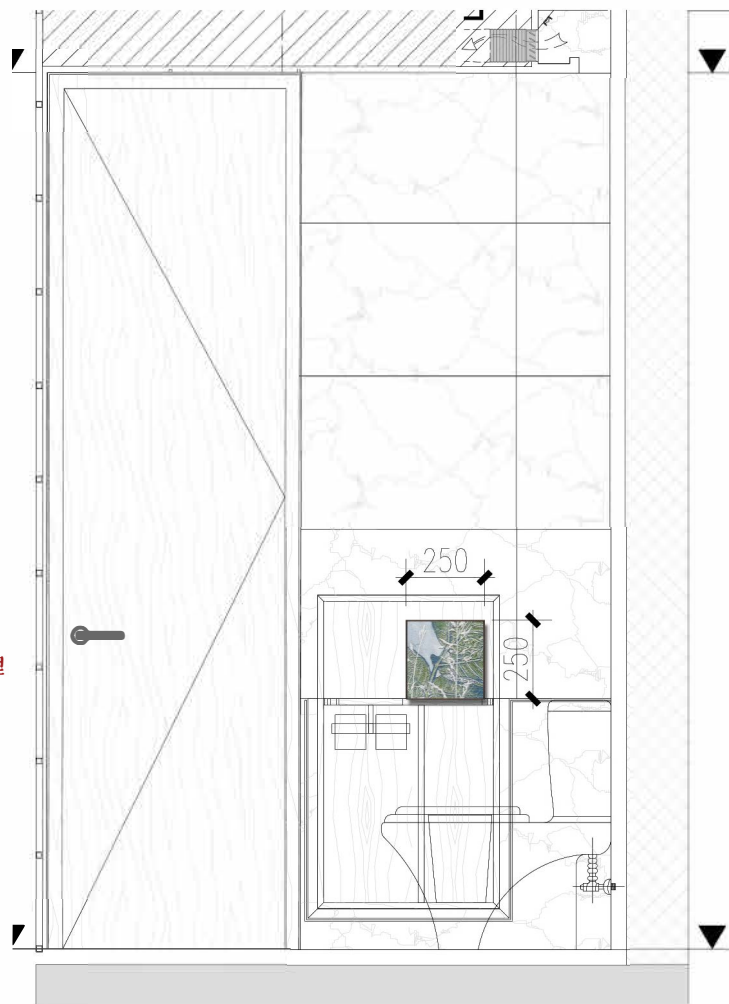

Furnishing articles and sculpture process requirements

摆件及雕塑工艺要求

- 1、 Art as the main theme, style, the main form of expression, need to have a strong visual impact
艺术品作为主题思想、风格的主要表现形式, 需要具有很强的视觉冲击力。
- 2、 First, the designer confirmed the design, selected processing materials.
首先草图, 效果图由设计师确认, 选定加工材料。
- 3、 According to the site, to determine the size of the sculpture.
根据现场, 图纸确定雕塑、摆件大小尺寸。
- 4、 Make mud draft, foam model, confirm the overall effect.
制作泥稿、泡沫模型, 确认整体效果。
- 5、 Indoor metal art material thickness shall not be less than 1.5 mm, resin thickness shall not be less than 3mm.
金属艺术品材料壁厚室内不得低于1.5mm,树脂壁厚不得低于3mm。
- 6、 Resin artwork surface color guarantee does not fade.
树脂艺术品表面颜色保证不褪色。
- 7、 Seamless metal joints, bending polished smooth.
金属接缝处无缝隙, 折弯处打磨光滑。
- 8、 摆件雕塑必须牢固、稳定、安全、与灯光很好结合。
- 9、 石材基座必须做好加重加固, 以防碰撞引起倒掉。
- 10、 落地安放艺术品要稳、安全。

灵感来源: 天目铁木



模型示意:

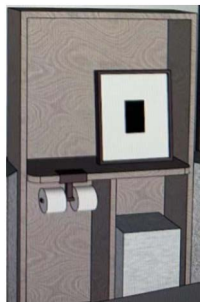

画框示意: 深棕色画框
面宽7mm, H:30mm。



注: 1、实际艺术品以中标单位现场核实具体尺寸数量再深化为准;
2、此点位需灯光照亮, 需灯光顾问配合处理。

平面图



2BS-1房型数量: 17件
2BS-2房型数量: 3件
2BS-3房型数量: 1件
GM房型数量: 1件

图片仅供参考, 以最终效果为准。

Project 项目名称: 杭州天目山格芮精选希尔顿酒店 Serial number 项目编号: 2BS-1-3、2BS-2-4、2BS-3-4、GM-5

Material 材质: 立体肌理+喷绘画面+深棕色画框

Process description 工艺说明:

Area 区域: 客房

Number 数量: 22组(每组两件)

Size 尺寸: W250*D30*H250

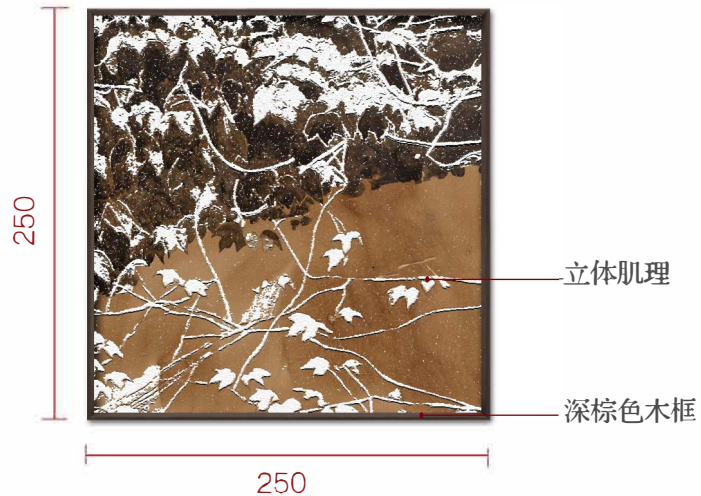

建议灯光从上往下打光。

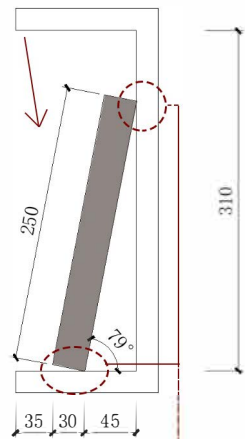

挂画侧着靠, 连接柜体处打胶处理

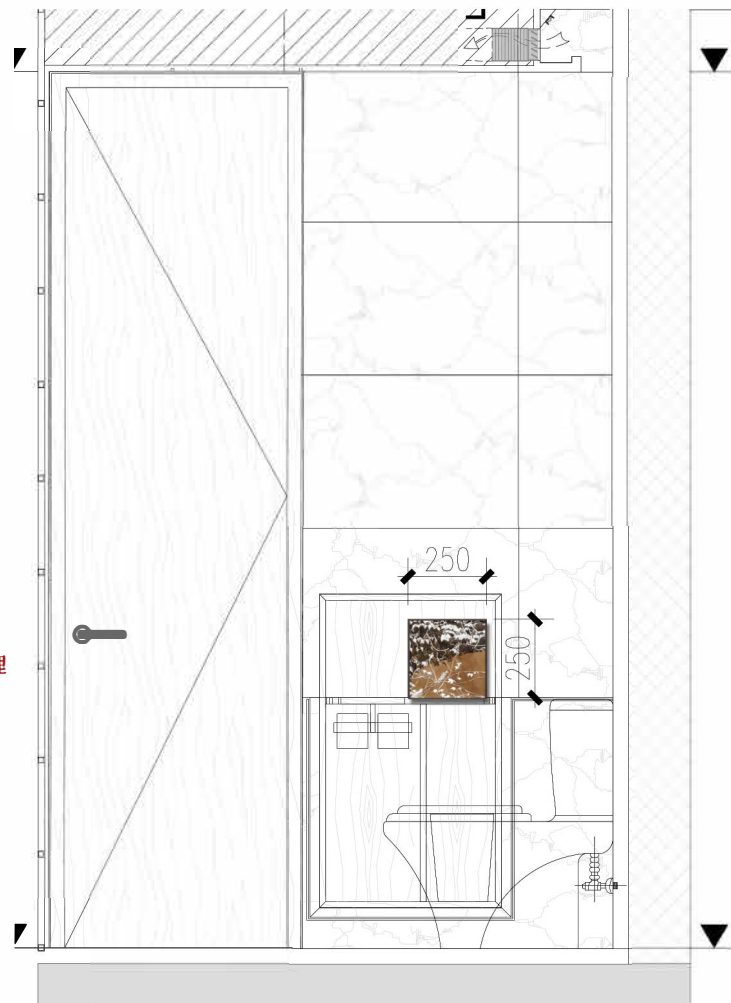

灵感来源: 秋日落叶

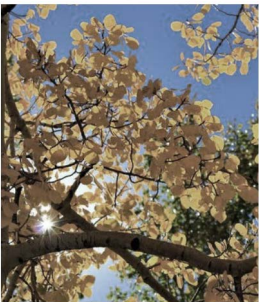

模型示意:



画框示意: 深棕色画框 面宽7mm, H:30mm.



Furnishing articles and sculpture process requirements

摆件及雕塑工艺要求

- 1、Art as the main theme, style, the main form of expression, need to have a strong visual impact
艺术品作为主题思想、风格的主要表现形式, 需要具有很强的视觉冲击力。
- 2、First, the designer confirmed the design, selected processing materials.
首先草图, 效果图由设计师确认, 选定加工材料。
- 3、According to the site, to determine the size of the sculpture.
根据现场, 图纸确定雕塑、摆件大小尺寸。
- 4、Make mud draft, foam model, confirm the overall effect.
制作泥稿、泡沫模型, 确认整体效果。
- 5、Indoor metal art material thickness shall not be less than 1.5 mm, resin thickness shall not be less than 3mm.
金属艺术品材料厚度室内不得低于1.5mm, 树脂厚度不得低于3mm。
- 6、Resin artwork surface color guarantee does not fade.
树脂艺术品表面颜色保证不褪色。
- 7、Seamless metal joints, bending polished smooth.
金属接缝处无缝隙, 折弯处打磨光滑。
- 8、摆件雕塑必须牢固、稳定、安全、与灯光很好结合。
- 9、石材基座必须做好加重加固, 以防碰撞引起倒掉。
- 10、落地安放艺术品要稳、安全。

平面图



2BS-1房型数量: 17件

2BS-2房型数量: 3件

2BS-3房型数量: 1件

GM房型数量: 1件

图片仅供参考, 以最终效果为准。

注: 1、实际艺术品以中标单位现场核实具体尺寸数量再深化为准;
2、此点位需灯光照亮, 需灯光顾问配合处理。

Project 项目名称: 杭州天目山格芮精选希尔顿酒店 Serial number 项目编号: 2BS-1-4、SBS-2-6、2BS-3-5、GM-6
Area 区域: 客房 Number 数量: 22组(每组两件)

Material 材质: 真书书籍
Size 尺寸: 成品尺寸书籍

Process description 工艺说明:



书籍选型: (有关天目山动植物或英文绿植花艺等书籍)



每个床头柜一本书

Furnishing articles and sculpture process requirements

摆件及雕塑工艺要求

1、 Art as the main theme, style, the main form of expression, need to have a strong visual impact

艺术品作为主题思想、风格的主要表现形式, 需要具有很强的视觉冲击力。

2、 First, the designer confirmed the design, selected processing materials.

首先草图, 效果图由设计师确认, 选定加工材料。

3、 According to the site, to determine the size of the sculpture. 根据现场, 图纸确定雕塑、摆件大小尺寸。

4、 Make mud draft, foam model, confirm the overall effect. 制作泥稿、泡沫模型, 确认整体效果。

5、 Indoor metal art material thickness shall not be less than 1.5 mm, resin thickness shall not be less than 3mm.

金属艺术品材料厚度室内不得低于1.5mm, 树脂厚度不得低于3mm。

6、 Resin artwork surface color guarantee does not fade. 树脂艺术品表面颜色保证不褪色。

7、 Seamless metal joints, bending polished smooth. 金属接缝处无缝隙, 折弯处打磨光滑。

8、 摆件雕塑必须牢固、稳定、安全、与灯光很好结合。

9、 石材基座必须做好加重加固, 以防碰撞引起倒掉。

10、 落地安放艺术品要稳、安全。

平面图

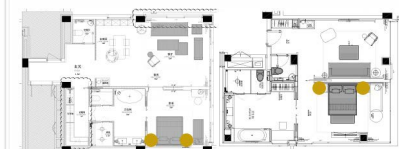

2BS-1房型数量: 17件

2BS-2房型数量: 3件

2BS-3房型数量: 1件

GM房型数量: 1件

图片仅供参考, 以最终效果为准。

注: 1、实际艺术品以中标单位现场核实具体尺寸数量再深化为准;

Project 项目名称: 杭州天目山格芮精选希尔顿酒店 Serial number 项目编号: GM-1

Material 材质: 艺术喷绘底图+叠加树脂造型+木质背板+无框直裱

Process description 工艺说明:

Area 区域: 客房

Number 数量: 1件

Size 尺寸: $\phi 1000 \times D60$

1000

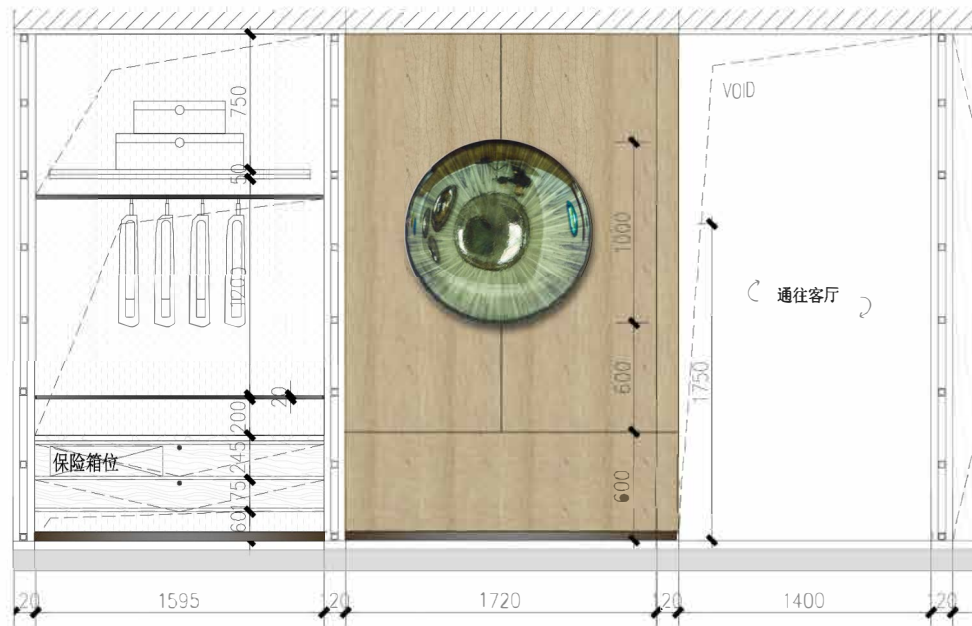
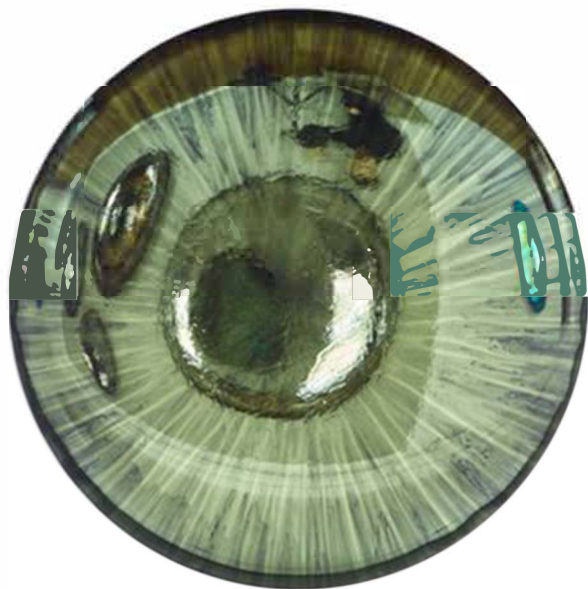

Furnishing articles and sculpture process requirements

摆件及雕塑工艺要求

- 1、Art as the main theme, style, the main form of expression, need to have a strong visual impact
艺术品作为主题思想、风格的主要表现形式, 需要具有很强的视觉冲击力。
- 2、First, the designer confirmed the design, selected processing materials.
首先草图, 效果图由设计师确认, 选定加工材料。
- 3、According to the site, to determine the size of the sculpture
根据现场, 图纸确定雕塑、摆件大小尺寸。
- 4、Make mud draft, foam model, confirm the overall effect.
制作泥稿、泡沫模型, 确认整体效果
- 5、Indoor metal art material thickness shall not be less than 1.5mm, resin thickness shall not be less than 3mm.
金属艺术品材料壁厚室内不得低于1.5mm, 树脂壁厚不得低于3mm。
- 6、Resin artwork surface color guarantee does not fade.
树脂艺术品表面颜色保证不褪色。
- 7、Seamless metal joints, bending polished smooth.
金属接缝处无缝隙, 折弯处打磨光滑。
- 8、摆件雕塑必须牢固、稳定、安全、与灯光很好结合。
- 9、石材基座必须做好加重加固, 以防碰撞引起倒塌。
- 10、落地安放艺术品要稳、安全。



凸起树脂造型
15mm~30mm



灵感来源: 树叶滴露

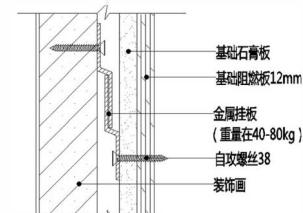

平面图

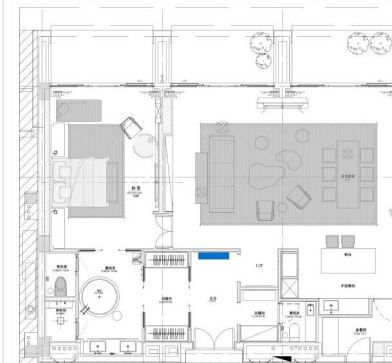

图片仅供参考, 以最终效果为准。

注: 1、实际艺术品以中标单位现场核实具体尺寸数量再深化为准;
2、此点位需灯光照亮, 需灯光顾问配合处理。

Project 项目名称: 杭州天目山格芮精选希尔顿酒店 Serial number 项目编号: GM-2

Material 材质: 木板切割画+手绘颜色+无框直裱

Process description 工艺说明:

Area 区域: 客房

Number 数量: 1件

Size 尺寸: W1300*H1300

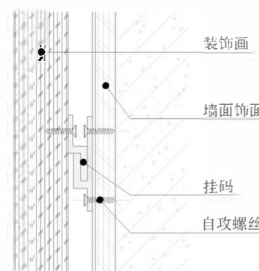
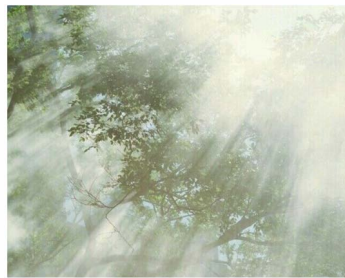
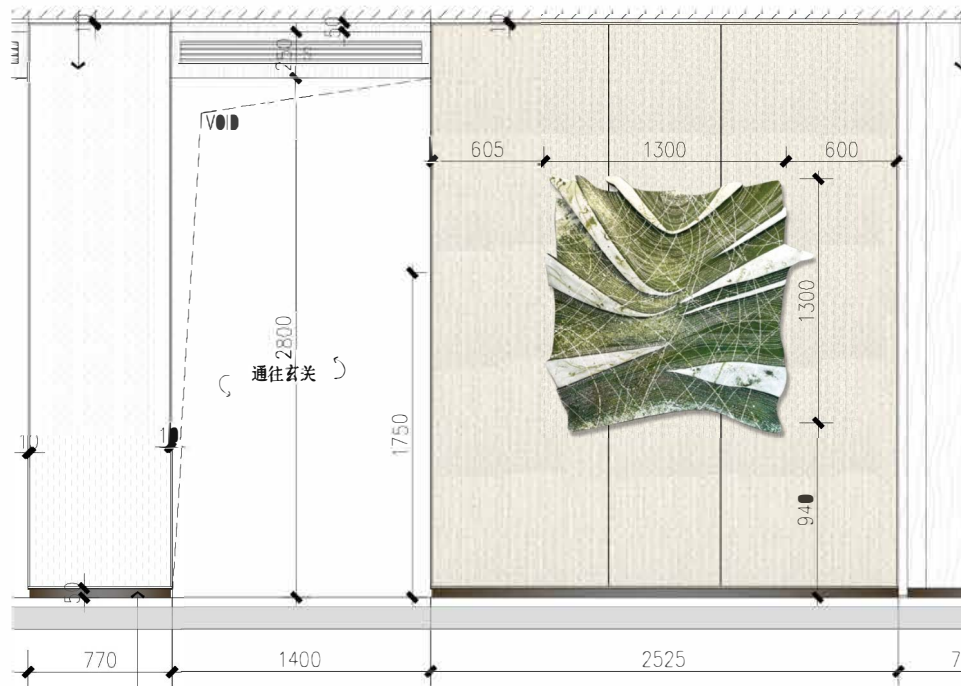
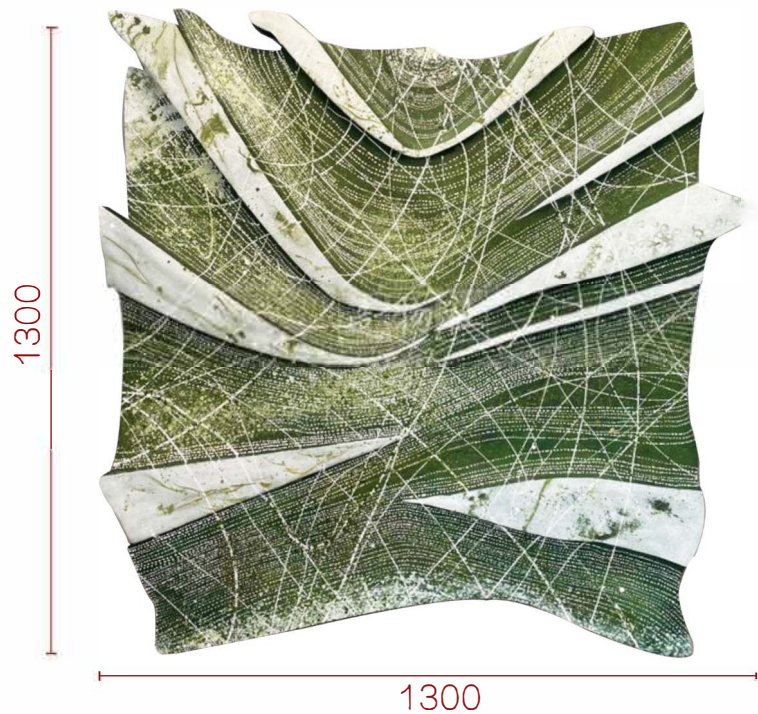

抽象运用叶脉的纹理，立体肌理的形式表现出树叶律动。

注: 1、实际艺术品以中标单位现场核实具体尺寸数量再深化为准;
2、此点位需灯光照亮, 需灯光顾问配合处理。

Furnishing articles and sculpture process requirements

摆件及雕塑工艺要求

- 1、Art as the main theme, style, the main form of expression, need to have a strong visual impact
艺术品作为主题思想、风格的主要表现形式, 需要具有很强的视觉冲击力。
- 2、First, the designer confirmed the design, selected processing materials.
首先草图, 效果图由设计师确认, 选定加工材料。
- 3、According to the site, to determine the size of the sculpture.
根据现场, 图纸确定雕塑、摆件大小尺寸。
- 4、Make mud draft, foam model, confirm the overall effect.
制作泥稿、泡沫模型, 确认整体效果。
- 5、Indoor metal art material thickness shall not be less than 1.5 mm, resin thickness shall not be less than 3mm.
金属艺术品材料厚度室内不得低于1.5mm, 树脂壁厚厚度不得低于3mm。
- 6、Resin artwork surface color guarantee does not fade.
树脂艺术品表面颜色保证不褪色。
- 7、Seamless metal joints, bending polished smooth.
金属接缝处无缝隙, 折弯处打磨光滑。
- 8、摆件雕塑必须牢固、稳定、安全、与灯光很好结合。
- 9、石材基座必须做好加重加固, 以防碰撞引起倒塌。
- 10、落地安放艺术品要稳、安全。

平面图

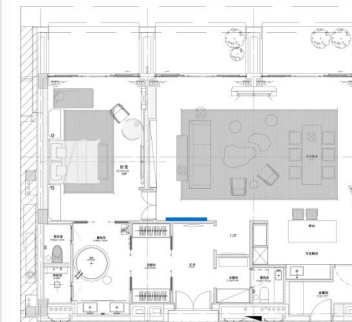

图片仅供参考, 以最终效果为准。



独栋客房

SINGLE FAMILY GUEST ROOMS

天目山的独特自然景观，独栋客房采用自然森林景象，
绿色自然，秋色风光，营造独特的度假氛围。

THE UNIQUE NATURAL LANDSCAPE OF TIANMU MOUNTAIN FEATURES A SINGLE GUEST ROOM FEATURING
NATURAL FOREST SCENERY, GREEN AND NATURAL, AND AUTUMN SCENERY, CREATING A UNIQUE VACA-
TION ATMOSPHERE.





2F独栋客厅效果图

RENDERINGS OF 2F STANDALONE LIVING ROOM



3F独栋卧室效果图

3F SINGLE BEDROOM RENDERING



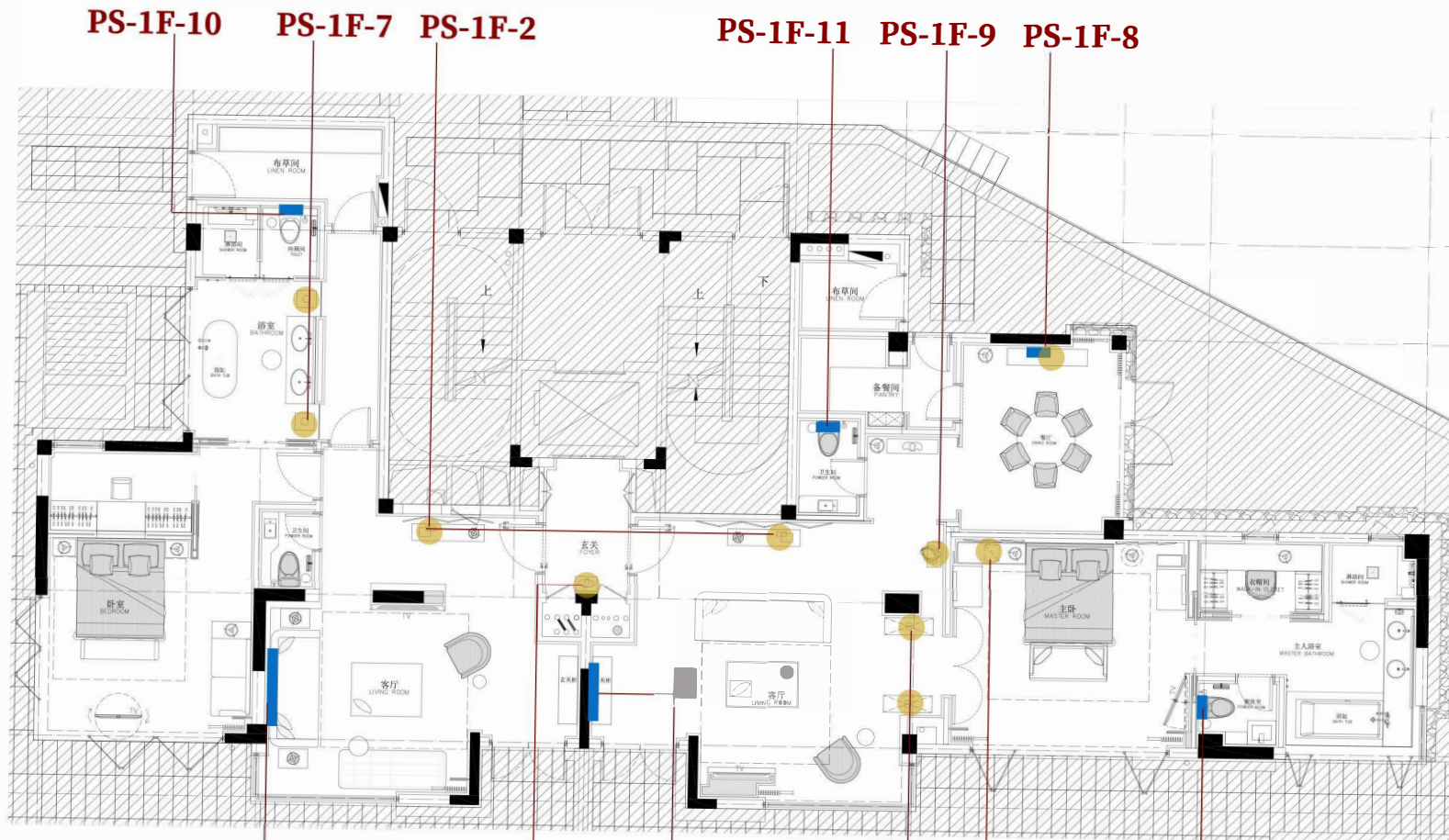

PS-1F-3

PS-1F-1

PS-1F-4

PS-1F-5

PS-1F-6

PS-1F-12

雕塑



A级



挂画



B级



摆件



C级



独栋客房1F平面图

注：所有艺术品点位位置需要灯光配合

独栋1F入户玄关

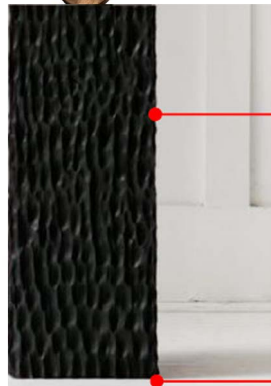

灵感来源: 铁木树杆



材质细节: 木纹纹路

Wood refer to WD-302
深色木饰面 WD-302
如图做特殊处理面

Nylon Glides
底部尼龙脚垫

注: 底座为硬装制作



注: 1、实际艺术品以中标单位现场核实具体尺寸数量再深化为准;
2、此点位需灯光照亮, 需灯光顾问配合处理。

Furnishing articles and sculpture process requirements

摆件及雕塑工艺要求

- 1、 Art as the main theme, style, the main form of expression, need to have a strong visual impact
艺术品作为主题思想、风格的主要表现形式, 需要具有很强的视觉冲击力。
- 2、 First, the designer confirmed the design, selected processing materials.
首先草图, 效果图由设计师确认, 选定加工材料。
- 3、 According to the site, to determine the size of the sculpture. 根据现场, 图纸确定雕塑、摆件大小尺寸。
- 4、 Make mud draft, foam model, confirm the overall effect. 制作泥稿、泡沫模型, 确认整体效果。
- 5、 Indoor metal art material thickness shall not be less than 1.5 mm, resin thickness shall not be less than 3mm.
金属艺术品材料厚度室内不得低于1.5mm, 树脂厚度不得低于3mm。
- 6、 Resin artwork surface color guarantee does not fade. 树脂艺术品表面颜色保证不褪色。
- 7、 Seamless metal joints, bending polished smooth. 金属接缝处无缝隙, 折弯处打磨光滑。
- 8、 摆件雕塑必须牢固、稳定、安全、与灯光很好结合。
- 9、 石材基座必须做好加重加固, 以防碰撞引起倒塌。
- 10、 落地安放艺术品要稳、安全。

平面图

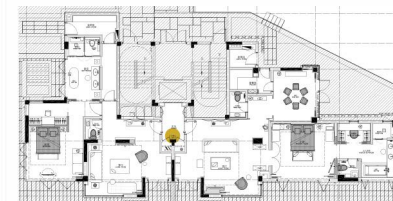

图片仅供参考, 以最终效果为准。

独栋1F客厅

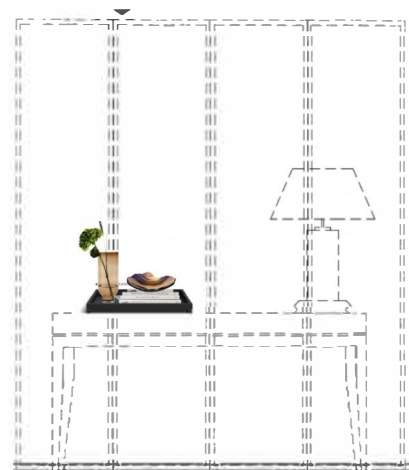

家具尺寸约: W1500*D350*H750

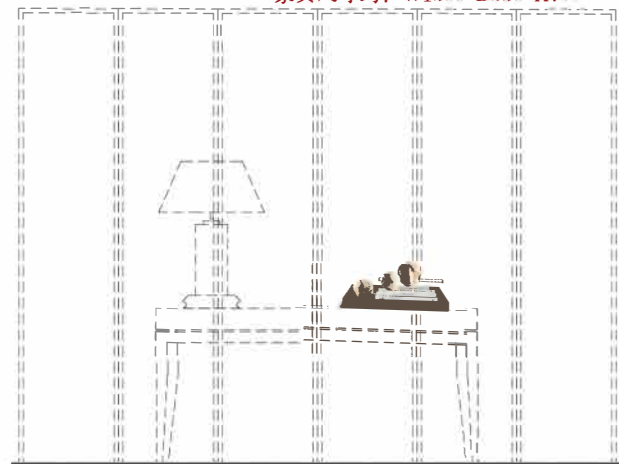

Furnishing articles and sculpture process requirements

摆件及雕塑工艺要求

- 1、Art as the main theme, style, the main form of expression, need to have a strong visual impact
艺术品作为主题思想、风格的主要表现形式, 需要具有很强的视觉冲击力。
- 2、First, the designer confirmed the design, selected processing materials.
首先草图, 效果图由设计师确认, 选定加工材料。
- 3、According to the site, to determine the size of the sculpture.
根据现场, 图纸确定雕塑、摆件大小尺寸。
- 4、Make mud draft, foam model, confirm the overall effect.
制作泥稿、泡沫模型, 确认整体效果。
- 5、Indoor metal art material thickness shall not be less than 1.5 mm, resin thickness shall not be less than 3mm.
金属艺术品材料厚度室内不得低于1.5mm,树脂厚度不得低于3mm。
- 6、Resin artwork surface color guarantee does not fade.
树脂艺术品表面颜色保证不褪色。
- 7、Seamless metal joints, bending polished smooth.
金属接缝处无缝隙, 折弯处打磨光滑。
- 8、摆件雕塑必须牢固、稳定、安全、与灯光很好结合。
- 9、石材基座必须做好加重加固, 以防碰撞引起倒掉。
- 10、落地安放艺术品要稳、安全。

平面图

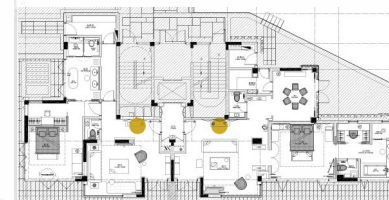

注: 1、实际艺术品以中标单位现场核实具体尺寸数量再深化为准;
2、此点位需灯光照亮, 需灯光顾问配合处理。

图片仅供参考, 以最终效果为准。

Project 项目名称: 杭州天目山格芮精选希尔顿酒店 Serial number 项目编号: PS-1F-3

Material 材质: 手绘艺术油画+黑色木框

Process description 工艺说明:

Area 区域: 独栋1F

Number 数量: 1件

Size 尺寸: W1000*D300*H800

独栋1F西侧客厅

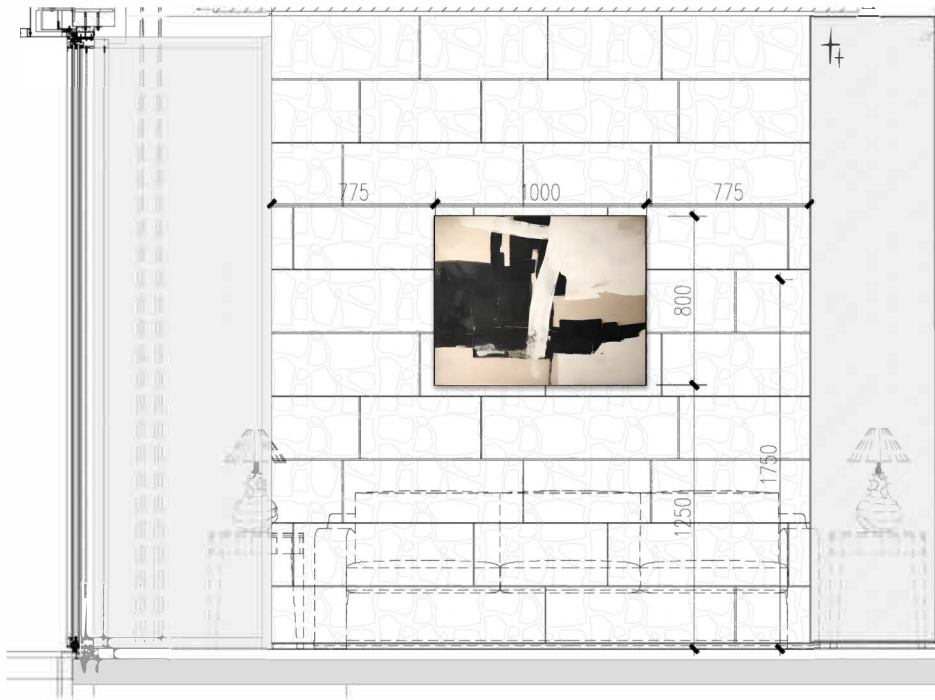
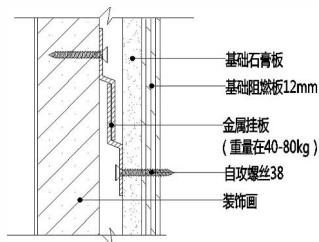

Furnishing articles and sculpture process requirements

摆件及雕塑工艺要求

- 1、 Art as the main theme, style, the main form of expression, need to have a strong visual impact
艺术品作为主题思想、风格的主要表现形式, 需要具有很强的视觉冲击力。
- 2、 First, the designer confirmed the design, selected processing materials.
首先草图, 效果图由设计师确认, 选定加工材料。
- 3、 According to the site, to determine the size of the sculpture.
根据现场, 图纸确定雕塑、摆件大小尺寸。
- 4、 Make mud draft, foam model, confirm the overall effect.
制作泥稿、泡沫模型, 确认整体效果。
- 5、 Indoor metal art material thickness shall not be less than 1.5 mm, resin thickness shall not be less than 3mm.
金属艺术品材料厚度室内不得低于1.5mm, 树脂壁厚不得低于3mm。
- 6、 Resin artwork surface color guarantee does not fade.
树脂艺术品表面颜色保证不褪色。
- 7、 Seamless metal joints, bending polished smooth.
金属接缝处无缝隙, 折弯处打磨光滑。
- 8、 摆件雕塑必须牢靠、稳定、安全、与灯光很好结合。
- 9、 石材基座必须做好加重加固, 以防碰撞引起倒掉。
- 10、 落地安放艺术品要稳、安全。

平面图

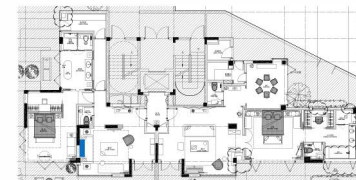

注: 1、实际艺术品以中标单位现场核实具体尺寸数量再深化为准;
2、此点位需灯光照亮, 需灯光顾问配合处理。

图片仅供参考, 以最终效果为准。

独栋1F 东侧客厅

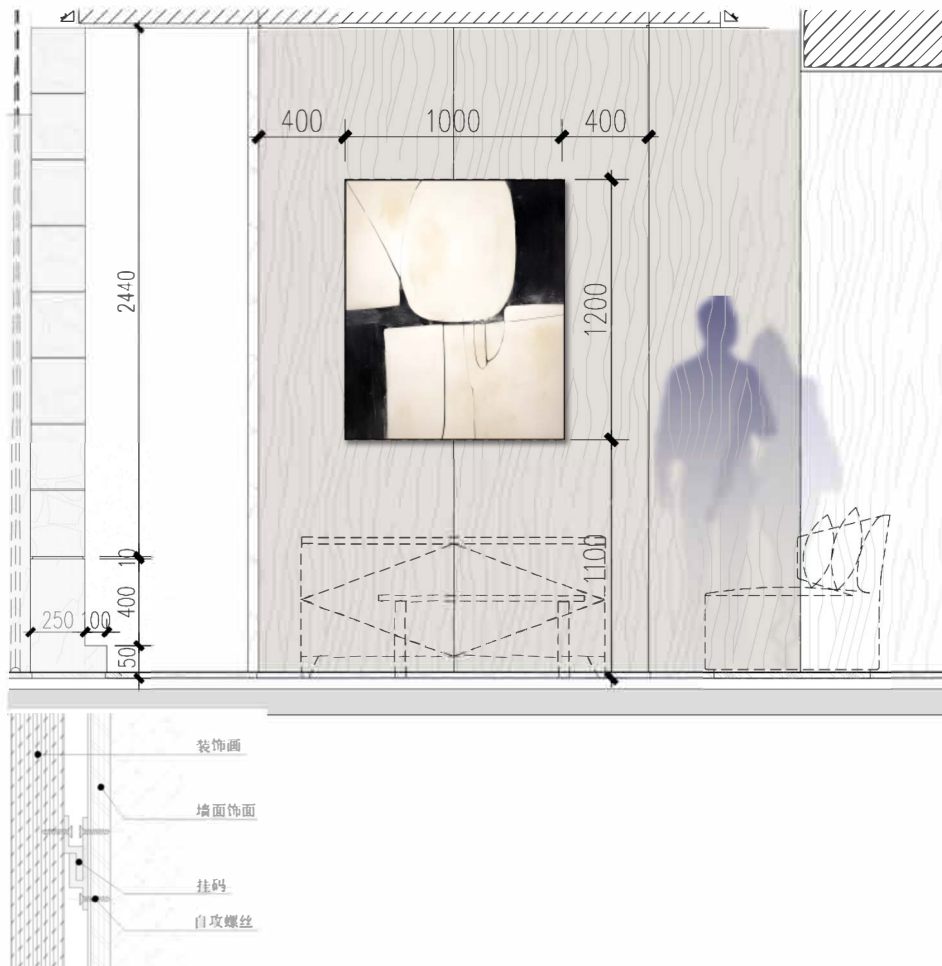

注: 1、实际艺术品以中标单位现场核实具体尺寸数量再深化为准;
2、此点位需灯光照亮, 需灯光顾问配合处理。

Furnishing articles and sculpture process requirements

摆件及雕塑工艺要求

- 1、 Art as the main theme, style, the main form of expression, need to have a strong visual impact
艺术品作为主题思想、风格的主要表现形式, 需要具有很强的视觉冲击力。
- 2、 First, the designer confirmed the design, selected processing materials.
首先草图, 效果图由设计师确认, 选定加工材料。
- 3、 According to the site, to determine the size of the sculpture.
根据现场, 图纸确定雕塑、摆件大小尺寸。
- 4、 Make mud draft, foam model, confirm the overall effect.
制作泥稿、泡沫模型, 确认整体效果。
- 5、 Indoor metal art material thickness shall not be less than 1.5 mm, resin thickness shall not be less than 3mm.
金属艺术品材料壁厚室内不得低于1.5mm, 树脂壁厚不得低于3mm。
- 6、 Resin artwork surface color guarantee does not fade.
树脂艺术品表面颜色保证不褪色。
- 7、 Seamless metal joints, bending polished smooth.
金属接缝处无缝隙, 折弯处打磨光滑。
- 8、 摆件雕塑必须牢固、稳定、安全、与灯光很好结合。
- 9、 石材基座必须做好加重加固, 以防碰撞引起倒掉。
- 10、 落地安放艺术品要稳、安全。

平面图

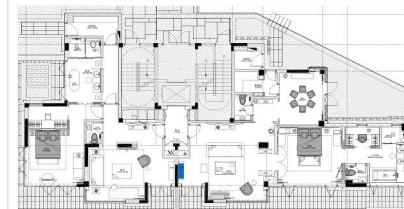

图片仅供参考, 以最终效果为准。

独栋1F东侧客厅

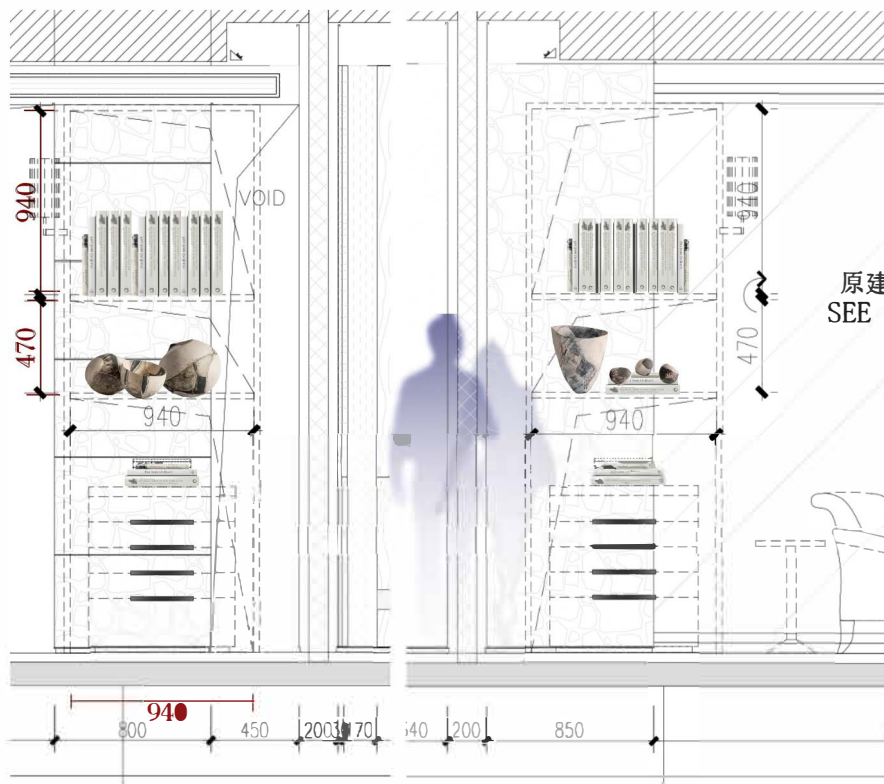

Furnishing articles and sculpture process requirements

摆件及雕塑工艺要求

- 1、Art as the main theme, style, the main form of expression, need to have a strong visual impact
艺术品作为主题思想、风格的主要表现形式, 需要具有很强的视觉冲击力。
- 2、First, the designer confirmed the design, selected processing materials.
首先草图, 效果图由设计师确认, 选定加工材料。
- 3、According to the site, to determine the size of the sculpture.
根据现场, 图纸确定雕塑、摆件大小尺寸。
- 4、Make mud draft, foam model, confirm the overall effect.
制作泥稿、泡沫模型, 确认整体效果。
- 5、Indoor metal art material thickness shall not be less than 1.5 mm, resin thickness shall not be less than 3mm.
金属艺术品材料壁厚室内不得低于1.5mm, 树脂壁厚不得低于3mm。
- 6、Resin artwork surface color guarantee does not fade.
树脂艺术品表面颜色保证不褪色。
- 7、Seamless metal joints, bending polished smooth.
金属接缝处无缝隙, 折弯处打磨光滑。
- 8、摆件雕塑必须牢固、稳定、安全、与灯光很好结合。
- 9、石材基座必须做好加重加固, 以防碰撞引起倒掉。
- 10、落地安放艺术品要稳、安全。

平面图

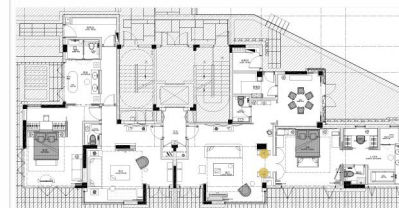

注: 1、实际艺术品以中标单位现场核实具体尺寸数量再深化为准;
2、此点位需灯光照亮, 需灯光顾问配合处理。

图片仅供参考, 以最终效果为准。

独栋1F东侧卧室

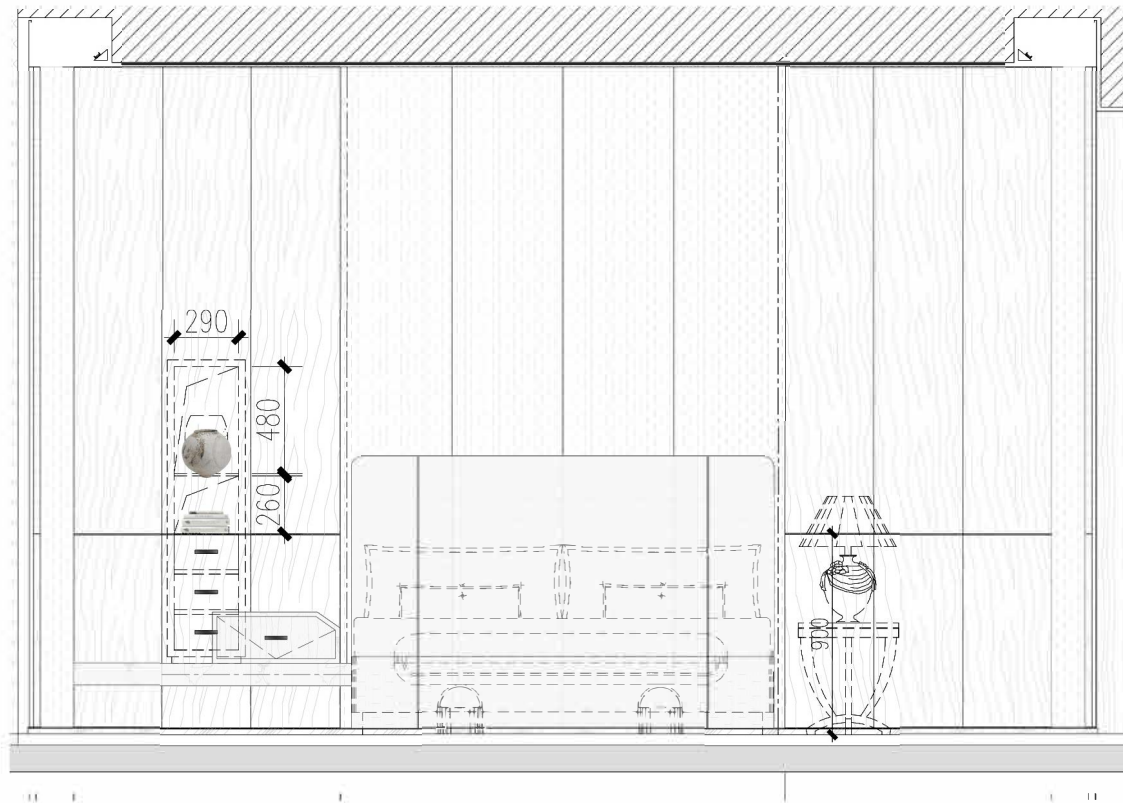

Furnishing articles and sculpture process requirements

摆件及雕塑工艺要求

- 1、Art as the main theme, style, the main form of expression, need to have a strong visual impact
艺术品作为主题思想、风格的主要表现形式, 需要具有很强的视觉冲击力。
- 2、First, the designer confirmed the design, selected processing materials.
首先草图, 效果图由设计师确认, 选定加工材料。
- 3、According to the site, to determine the size of the sculpture.
根据现场, 图纸确定雕塑、摆件大小尺寸。
- 4、Make mud draft, foam model, confirm the overall effect.
制作泥稿、泡沫模型, 确认整体效果。
- 5、Indoor metal art material thickness shall not be less than 1.5 mm, resin thickness shall not be less than 3mm.
金属艺术品材料壁厚室内不得低于1.5mm,树脂壁厚不得低于3mm。
- 6、Resin artwork surface color guarantee does not fade.
树脂艺术品表面颜色保证不褪色。
- 7、Seamless metal joints, bending polished smooth.
金属接缝处无缝隙, 折弯处打磨光滑。
- 8、摆件雕塑必须牢靠、稳定、安全、与灯光很好结合。
- 9、石材基座必须做好加重加固, 以防碰撞引起倒掉。
- 10、落地安放艺术品要稳、安全。

平面图

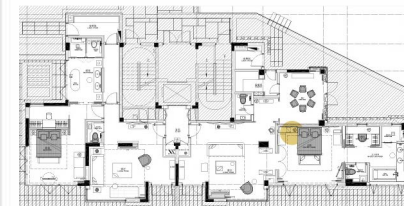

注: 1、实际艺术品以中标单位现场核实具体尺寸数量再深化为准;
2、此点位需灯光照亮, 需灯光顾问配合处理。

图片仅供参考, 以最终效果为准。

独栋客房1F

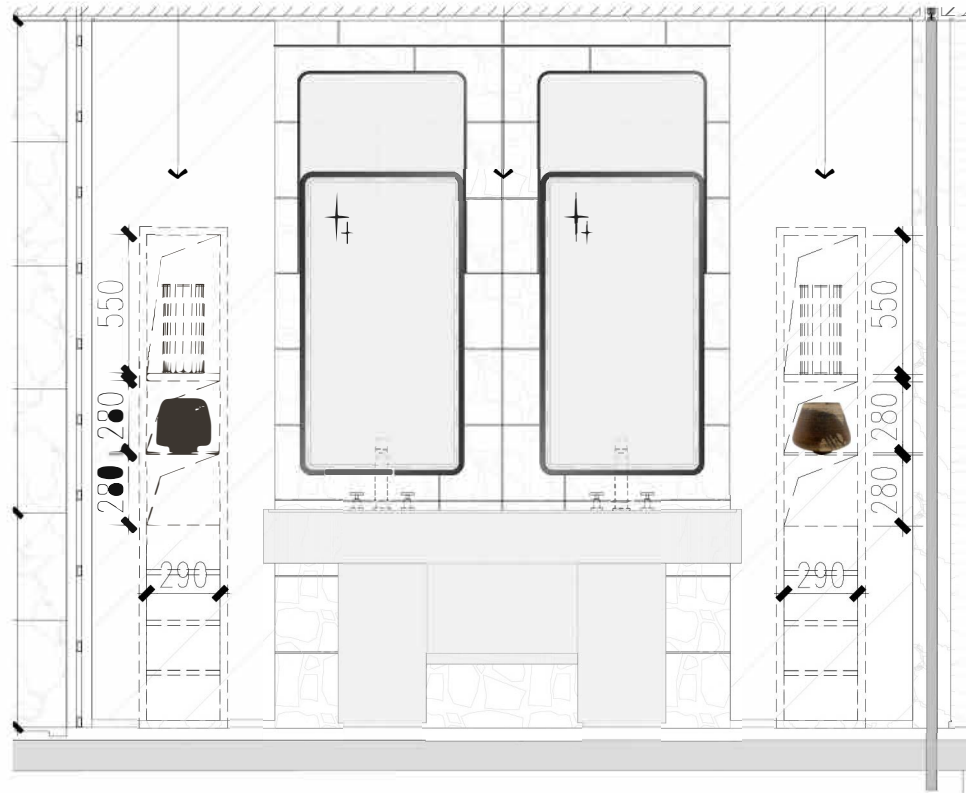

Furnishing articles and sculpture process requirements

摆件及雕塑工艺要求

- 1、 Art as the main theme, style, the main form of expression, need to have a strong visual impact
艺术品作为主题思想、风格的主要表现形式, 需要具有很强的视觉冲击力。
- 2、 First, the designer confirmed the design, selected processing materials.
首先草图, 效果图由设计师确认, 选定加工材料。
- 3、 According to the site, to determine the size of the sculpture.
根据现场, 图纸确定雕塑、摆件大小尺寸。
- 4、 Make mud draft, foam model, confirm the overall effect.
制作泥稿、泡沫模型, 确认整体效果。
- 5、 Indoor metal art material thickness shall not be less than 1.5 mm, resin thickness shall not be less than 3mm.
金属艺术品材料壁厚室内不得低于1.5mm, 树脂壁厚不得低于3mm。
- 6、 Resin artwork surface color guarantee does not fade.
树脂艺术品表面颜色保证不褪色。
- 7、 Seamless metal joints, bending polished smooth.
金属接缝处无缝隙, 折弯处打磨光滑。
- 8、 摆件雕塑必须牢固、稳定、安全、与灯光很好结合。
- 9、 石材基座必须做好加重加固, 以防碰撞引起倒掉。
- 10、 落地安放艺术品要稳、安全。

平面图

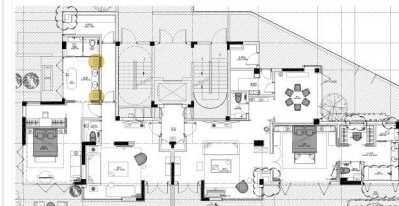

注: 1、实际艺术品以中标单位现场核实具体尺寸数量再深化为准;
2、此点位需灯光照亮, 需灯光顾问配合处理。

图片仅供参考, 以最终效果为准。

Project 项目名称: 杭州天目山格芮精选希尔顿酒店 Serial number 项目编号: PS-1F-8

Area 区域: 独栋1F

Number 数量: 1组

Material 材质: 手绘艺术油画+黑色木框+仿真花艺+金属花器

Size 尺寸: W600*D30*H600, 花艺: W610*H450

Process description 工艺说明:

独栋客房1F餐厅

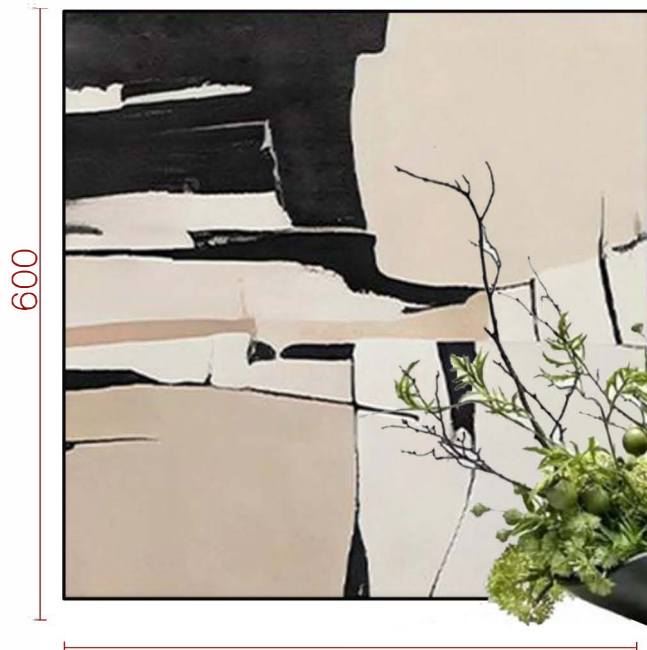

600



Furnishing articles and sculpture process requirements

摆件及雕塑工艺要求

1、Art as the main theme, style, the main form of expression, need to have a strong visual impact

艺术品作为主题思想、风格的主要表现形式, 需要具有很强的视觉冲击力。

2、First, the designer confirmed the design, selected processing materials.

首先草图, 效果图由设计师确认, 选定加工材料。

3、According to the site, to determine the size of the sculpture. 根据现场, 图纸确定雕塑、摆件大小尺寸。

4、Make mud draft, foam model, confirm the overall effect. 制作泥稿、泡沫模型, 确认整体效果。

5、Indoor metal art material thickness shall not be less than 1.5 mm, resin thickness shall not be less than 3mm.

金属艺术品材料壁厚室内不得低于1.5mm, 树脂壁厚度不得低于3mm。

6、Resin artwork surface color guarantee does not fade. 树脂艺术品表面颜色保证不褪色。

7、Seamless metal joints, bending polished smooth. 金属接缝处无缝隙, 折弯处打磨光滑。

8、摆件雕塑必须牢固、稳定、安全、与灯光很好结合。

9、石材基座必须做好加重加固, 以防碰撞引起倒塌。

10、落地安放艺术品要稳、安全。

平面图

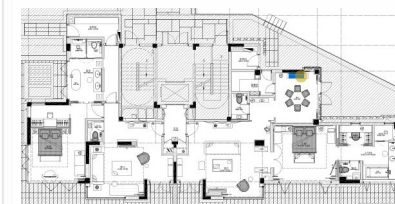

注: 1、实际艺术品以中标单位现场核实具体尺寸数量再深化为准;
2、此点位需灯光照亮, 需灯光顾问配合处理。

图片仅供参考, 以最终效果为准。

独栋1F东侧客厅

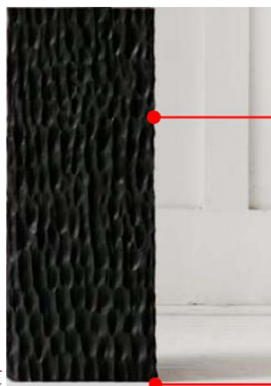

Wood refer to WD-302
深色木饰面 WD-302
如图做特殊处理面

Nylon Glides
底部尼龍脚垫

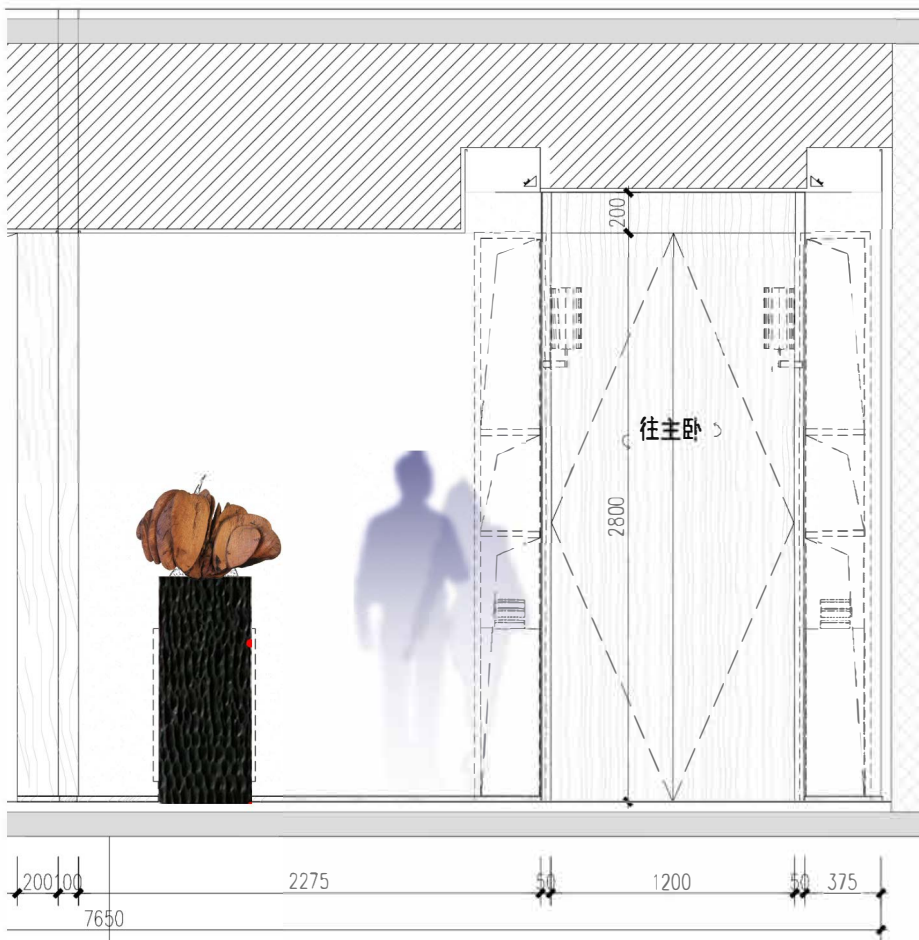

注: 1、实际艺术品以中标单位现场核实具体尺寸数量再深化为准;
2、此点位需灯光照亮, 需灯光顾问配合处理。

Furnishing articles and sculpture process requirements

摆件及雕塑工艺要求

- 1、 Art as the main theme, style, the main form of expression, need to have a strong visual impact
艺术品作为主题思想、风格的主要表现形式, 需要具有很强的视觉冲击力。
- 2、 First, the designer confirmed the design, selected processing materials.
首先草图, 效果图由设计师确认, 选定加工材料。
- 3、 According to the site, to determine the size of the sculpture.
根据现场, 图纸确定雕塑、摆件大小尺寸。
- 4、 Make mud draft, foam model, confirm the overall effect.
制作泥稿、泡沫模型, 确认整体效果。
- 5、 Indoor metal art material thickness shall not be less than 1.5 mm, resin thickness shall not be less than 3mm.
金属艺术品材料壁厚室内不得低于1.5mm, 树脂壁厚不得低于3mm。
- 6、 Resin artwork surface color guarantee does not fade.
树脂艺术品表面颜色保证不褪色。
- 7、 Seamless metal joints, bending polished smooth.
金属接缝处无缝隙, 折弯处打磨光滑。
- 8、 摆件雕塑必须牢固、稳定、安全、与灯光很好结合。
- 9、 石材基座必须做好加重加固, 以防碰撞引起倒塌。
- 10、 落地安放艺术品要稳、安全。

平面图

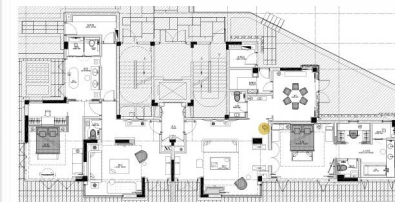

图片仅供参考, 以最终效果为准。

注: 底座为硬装制作

独栋1F 西侧卫生间、2F卫生间

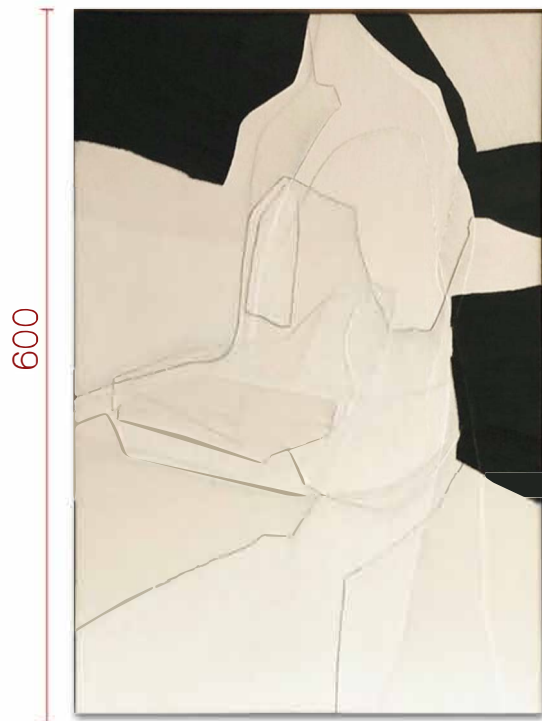

600

400

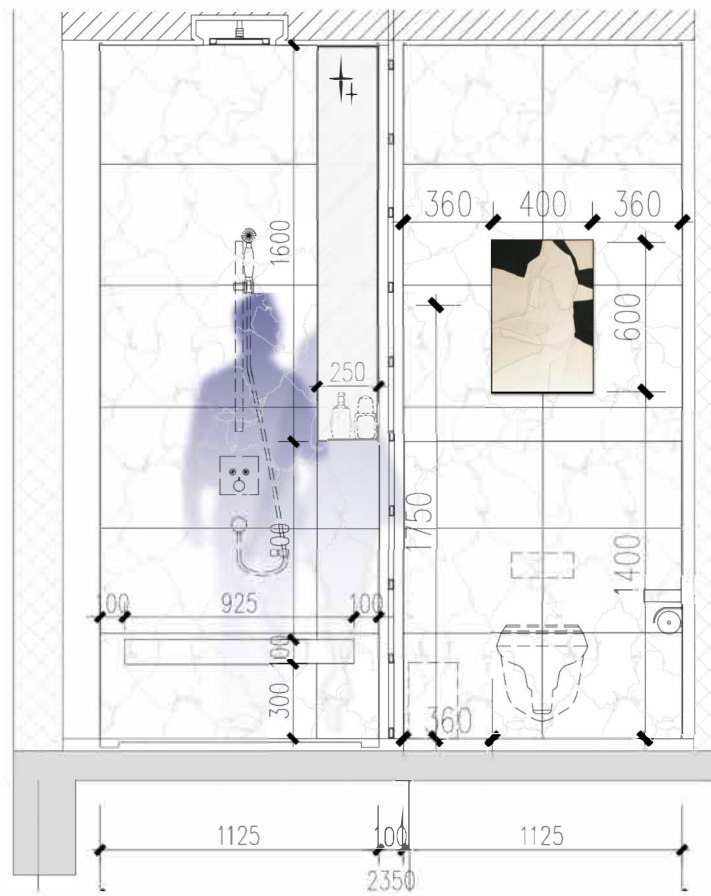
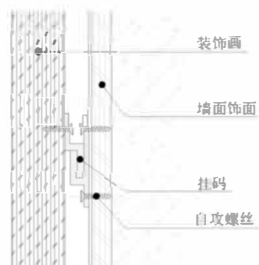

Furnishing articles and sculpture process requirements

摆件及雕塑工艺要求

- 1、Art as the main theme, style, the main form of expression, need to have a strong visual impact
艺术品作为主题思想、风格的主要表现形式, 需要具有很强的视觉冲击力。
- 2、First, the designer confirmed the design, selected processing materials.
首先草图, 效果图由设计师确认, 选定加工材料。
- 3、According to the site, to determine the size of the sculpture.
根据现场, 图纸确定雕塑、摆件大小尺寸。
- 4、Make mud draft, foam model, confirm the overall effect.
制作泥稿、泡沫模型, 确认整体效果。
- 5、Indoor metal art material thickness shall not be less than 1.5 mm, resin thickness shall not be less than 3mm.
金属艺术品材料厚度室内不得低于1.5mm, 树脂厚度不得低于3mm。
- 6、Resin artwork surface color guarantee does not fade.
树脂艺术品表面颜色保证不褪色。
- 7、Seamless metal joints, bending polished smooth.
金属接缝处无缝隙, 折弯处打磨光滑。
- 8、摆件雕塑必须牢固、稳定、安全、与灯光很好结合。
- 9、石材基座必须做好加重加固, 以防碰撞引起倒掉。
- 10、落地安放艺术品要稳、安全。

平面图



1F

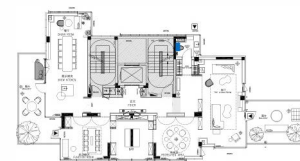

2F

图片仅供参考, 以最终效果为准。

注: 1、实际艺术品以中标单位现场核实具体尺寸数量再深化为准;
2、此点位需灯光照亮, 需灯光顾问配合处理。

独栋1F 东侧客厅卫生间、3F西侧卫生间



400

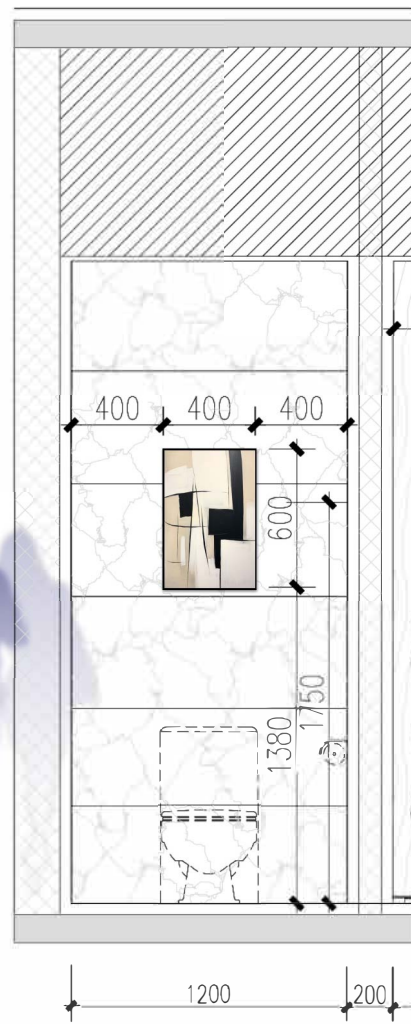
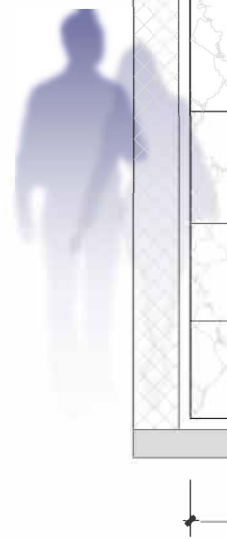
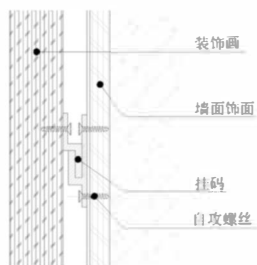

Furnishing articles and sculpture process requirements

摆件及雕塑工艺要求

- 1、Art as the main theme, style, the main form of expression, need to have a strong visual impact
艺术品作为主题思想、风格的主要表现形式，需要具有很强的视觉冲击力。
- 2、First, the designer confirmed the design, selected processing materials.
首先草图，效果图由设计师确认，选定加工材料。
- 3、According to the site, to determine the size of the sculpture.
根据现场，图纸确定雕塑、摆件大小尺寸。
- 4、Make mud draft, foam model, confirm the overall effect.
制作泥稿、泡沫模型，确认整体效果。
- 5、Indoor metal art material thickness shall not be less than 1.5 mm, resin thickness shall not be less than 3mm.
金属艺术品材料厚度室内不得低于1.5mm,树脂厚度不得低于3mm。
- 6、Resin artwork surface color guarantee does not fade.
树脂艺术品表面颜色保证不褪色。
- 7、Seamless metal joints, bending polished smooth.
金属接缝处无缝隙，折弯处打磨光滑。
- 8、摆件雕塑必须牢固、稳定、安全、与灯光很好结合。
- 9、石材基座必须做好加重加固，以防碰撞引起倒塌。
- 10、落地安放艺术品要稳、安全。

平面图

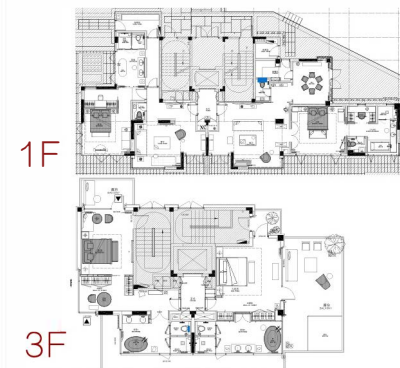

图片仅供参考，以最终效果为准。

注： 1、实际艺术品以中标单位现场核实具体尺寸数量再深化为准；
2、此点位需灯光照亮，需灯光顾问配合处理。

独栋1F 东侧卧室卫生间、3F东侧卫生间



600

400

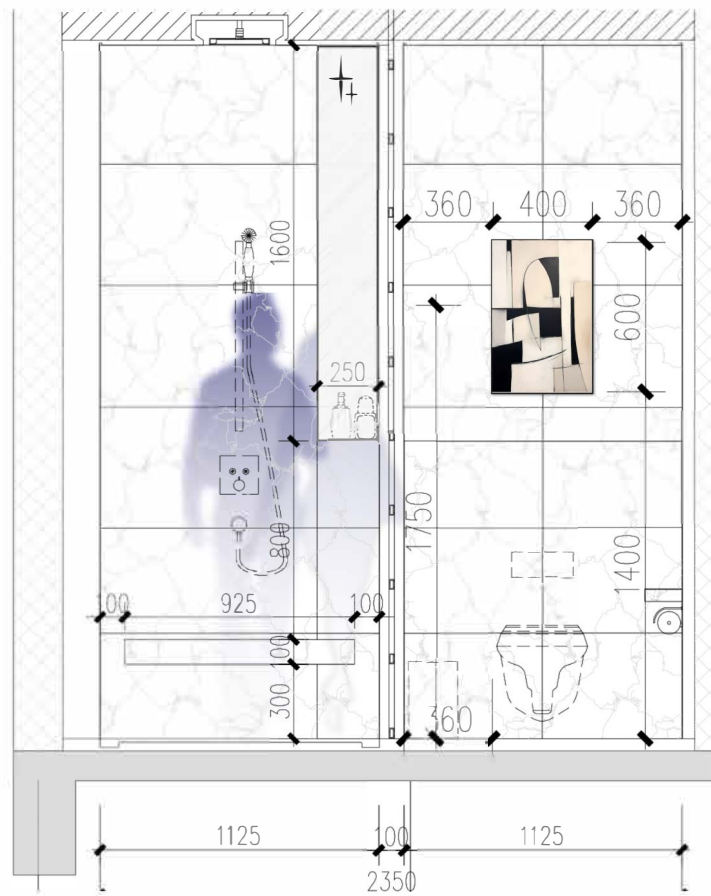
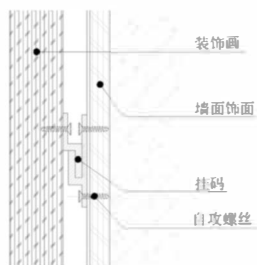

Furnishing articles and sculpture process requirements

摆件及雕塑工艺要求

- 1、Art as the main theme, style, the main form of expression, need to have a strong visual impact
艺术品作为主题思想、风格的主要表现形式, 需要具有很强的视觉冲击力。
- 2、First, the designer confirmed the design, selected processing materials.
首先草图, 效果图由设计师确认, 选定加工材料。
- 3、According to the site, to determine the size of the sculpture.
根据现场, 图纸确定雕塑、摆件大小尺寸。
- 4、Make mud draft, foam model, confirm the overall effect.
制作泥稿、泡沫模型, 确认整体效果。
- 5、Indoor metal art material thickness shall not be less than 1.5 mm, resin thickness shall not be less than 3mm.
金属艺术品材料壁厚室内不得低于1.5mm, 树脂壁厚不得低于3mm。
- 6、Resin artwork surface color guarantee does not fade.
树脂艺术品表面颜色保证不褪色。
- 7、Seamless metal joints, bending polished smooth.
金属接缝处无缝隙, 折弯处打磨光滑。
- 8、摆件雕塑必须牢固、稳定、安全、与灯光很好结合。
- 9、石材基座必须做好加重加固, 以防碰撞引起倒塌。
- 10、落地安放艺术品要稳、安全。

平面图

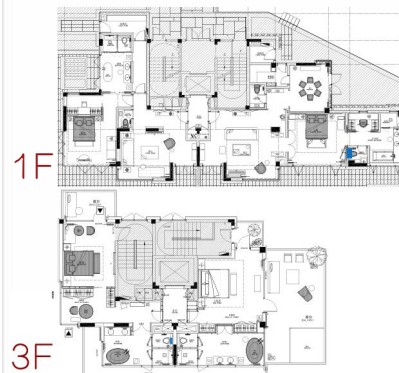

图片仅供参考, 以最终效果为准。

注: 1、实际艺术品以中标单位现场核实具体尺寸数量再深化为准; 2、此点位需灯光照亮, 需灯光顾问配合处理。

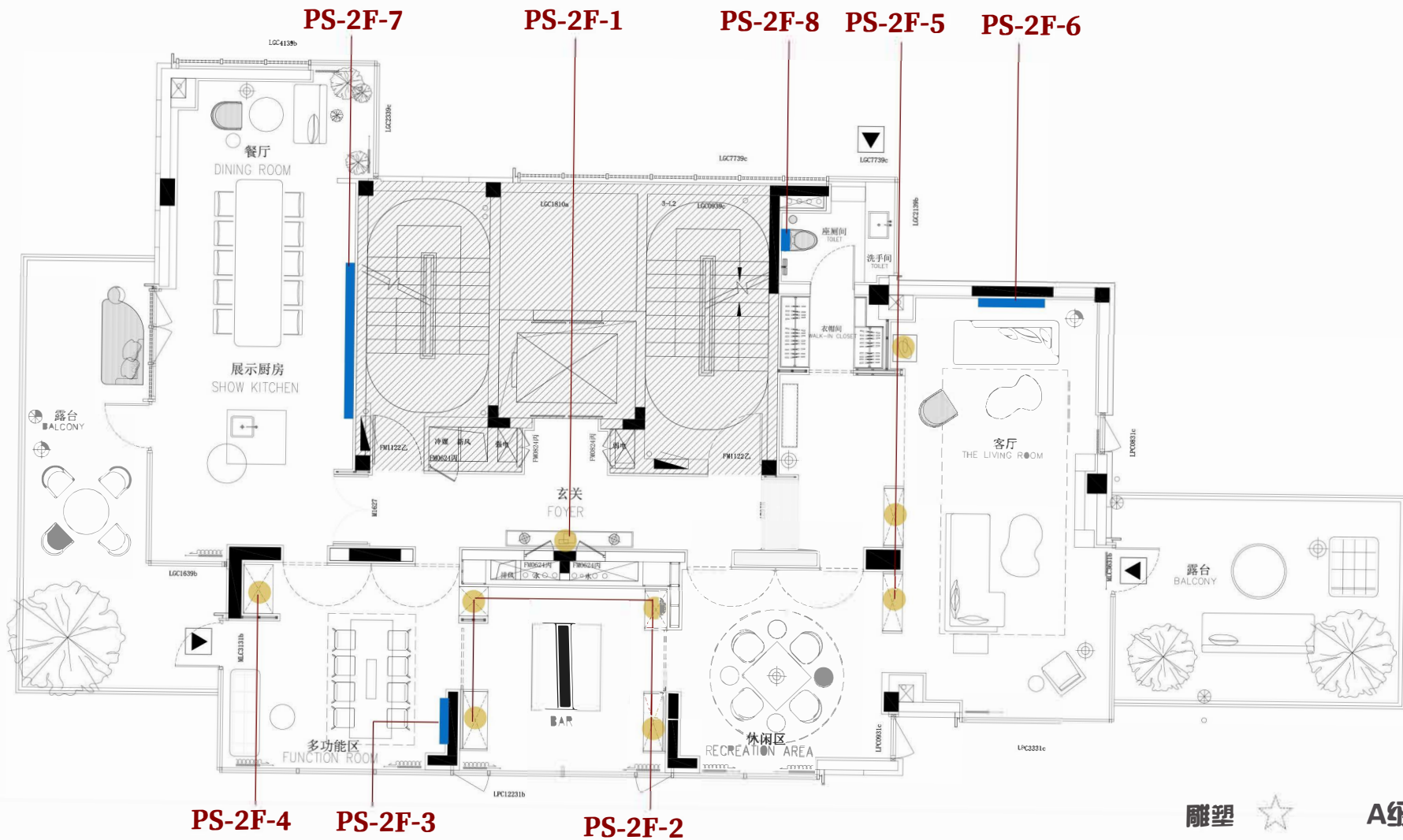

独栋客房2F平面图

注：所有艺术品点位位置需要灯光配合

Project 项目名称: 杭州天目山格芮精选希尔顿酒店 Serial number 项目编号: PS-2F-1

Material 材质: 仿真花艺+藤编+仿真绿植+陶瓷花器

Process description 工艺说明:

Area 区域: 客房

Number 数量: 1件

Size 尺寸: W1500*H1000, 花器: W320*H320

独栋客房2F



家具尺寸: W2400*H800



注: 1、实际艺术品以中标单位现场核实具体尺寸数量再深化为准;
 2、此点位需灯光照亮, 需灯光顾问配合处理。
 3、花艺仅提供一次, 后续由酒店运营进行花艺维护。

Furnishing articles and sculpture process requirements

摆件及雕塑工艺要求

1、 Art as the main theme, style, the main form of expression, need to have a strong visual impact

艺术品作为主题思想、风格的主要表现形式, 需要具有很强的视觉冲击力。

2、 First, the designer confirmed the design, selected processing materials.

首先草图, 效果图由设计师确认, 选定加工材料。

3、 According to the site, to determine the size of the sculpture. 根据现场, 图纸确定雕塑、摆件大小尺寸。

4、 Make mud draft, foam model, confirm the overall effect. 制作泥稿、泡沫模型, 确认整体效果。

5、 Indoor metal art material thickness shall not be less than 1.5 mm, resin thickness shall not be less than 3mm.

金属艺术品材料壁厚室内不得低于1.5mm, 树脂壁厚不得低于3mm。

6、 Resin artwork surface color guarantee does not fade. 树脂艺术品表面颜色保证不褪色。

7、 Seamless metal joints, bending polished smooth. 金属接缝处无缝隙, 折弯处打磨光滑。

8、 摆件雕塑必须牢固、稳定、安全、与灯光很好结合。

9、 石材基座必须做好加重加固, 以防碰撞引起倒塌。

10、 落地安放艺术品要稳、安全。

平面图

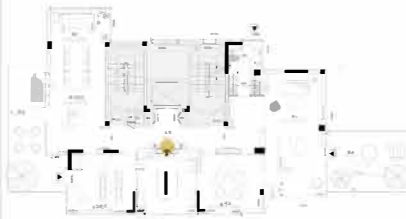

图片仅供参考, 以最终效果为准。

独栋客房2F



Furnishing articles and sculpture process requirements

摆件及雕塑工艺要求

- 1、 Art as the main theme, style, the main form of expression, need to have a strong visual impact
艺术品作为主题思想、风格的主要表现形式, 需要具有很强的视觉冲击力。
- 2、 First, the designer confirmed the design, selected processing materials.
首先草图, 效果图由设计师确认, 选定加工材料。
- 3、 According to the site, to determine the size of the sculpture.
根据现场, 图纸确定雕塑、摆件大小尺寸。
- 4、 Make mud draft, foam model, confirm the overall effect.
制作泥稿、泡沫模型, 确认整体效果。
- 5、 Indoor metal art material thickness shall not be less than 1.5 mm, resin thickness shall not be less than 3mm.
金属艺术品材料厚度室内不得低于1.5mm,树脂壁厚度不得低于3mm。
- 6、 Resin artwork surface color guarantee does not fade.
树脂艺术品表面颜色保证不褪色。
- 7、 Seamless metal joints, bending polished smooth.
金属接缝处无缝隙, 折弯处打磨光滑。
- 8、 摆件雕塑必须牢固、稳定、安全、与灯光很好结合。
- 9、 石材基座必须做好加重加固, 以防碰撞引起倒掉。
- 10、 落地安放艺术品要稳、安全。

平面图

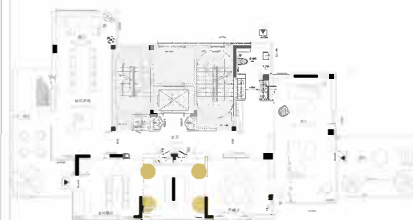

注: 1、实际艺术品以中标单位现场核实具体尺寸数量再深化为准;
2、此点位需灯光照亮, 需灯光顾问配合处理。

图片仅供参考, 以最终效果为准。

独栋2F多功能室



1200

1000

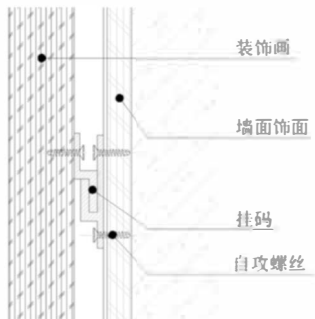

Furnishing articles and sculpture process requirements

摆件及雕塑工艺要求

- 1、Art as the main theme, style, the main form of expression, need to have a strong visual impact
艺术品作为主题思想、风格的主要表现形式，需要具有很强的视觉冲击力。
- 2、First, the designer confirmed the design, selected processing materials.
首先草图，效果图由设计师确认，选定加工材料。
- 3、According to the site, to determine the size of the sculpture.
根据现场，图纸确定雕塑、摆件大小尺寸。
- 4、Make mud draft, foam model, confirm the overall effect.
制作泥稿、泡沫模型，确认整体效果。
- 5、Indoor metal art material thickness shall not be less than 1.5 mm, resin thickness shall not be less than 3mm.
金属艺术品材料壁厚室内不得低于1.5mm,树脂壁厚度不得低于3mm。
- 6、Resin artwork surface color guarantee does not fade.
树脂艺术品表面颜色保证不褪色。
- 7、Seamless metal joints, bending polished smooth.
金属接缝处无缝隙，折弯处打磨光滑。
- 8、摆件雕塑必须牢固、稳定、安全、与灯光很好结合。
- 9、石材基座必须做好加重加固，以防碰撞引起倒掉。
- 10、落地安放艺术品要稳、安全。

平面图

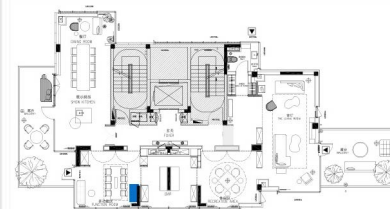

注： 1、实际艺术品以中标单位现场核实具体尺寸数量再深化为准；
2、此点位需灯光照亮，需灯光顾问配合处理。

图片仅供参考，以最终效果为准。

Project 项目名称: 杭州天目山格芮精选希尔顿酒店 Serial number 项目编号: PS-2F-5

Material 材质: 木质+陶瓷+金属+真书书籍

Process description 工艺说明:

Area 区域: 独栋2F

Number 数量: 1组

Size 尺寸: 雕塑: W750*H550, 其余详见清单

独栋2F客厅

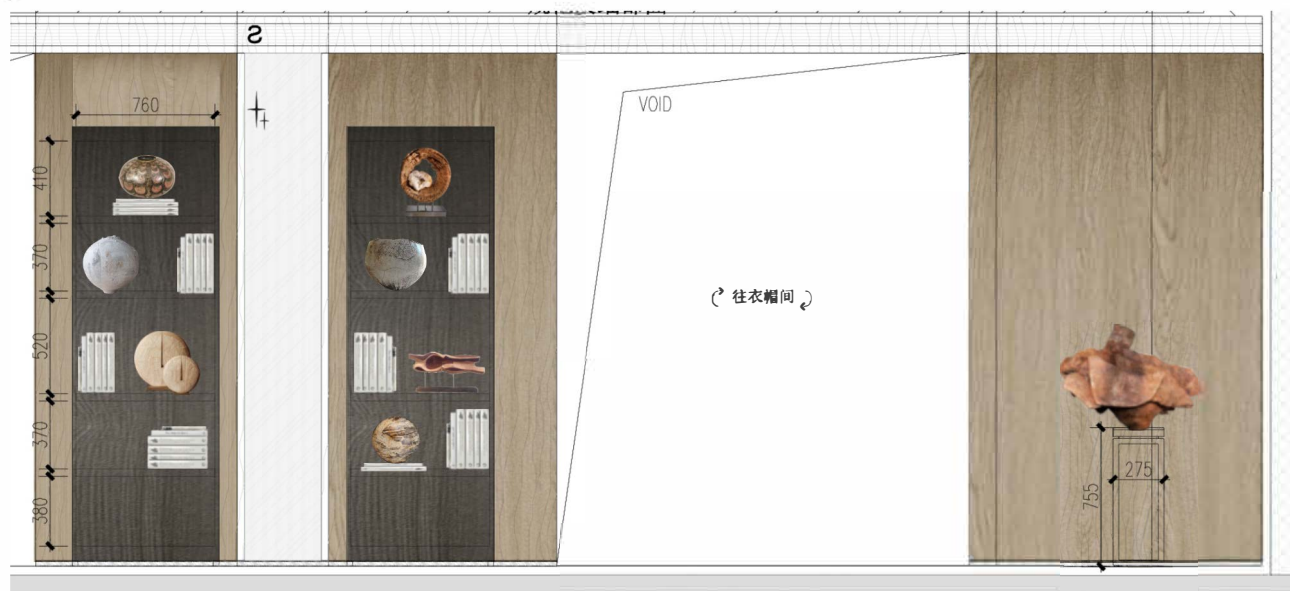

Furnishing articles and sculpture process requirements

摆件及雕塑工艺要求

1、 Art as the main theme, style, the main form of expression, need to have a strong visual impact

艺术品作为主题思想、风格的主要表现形式, 需要具有很强的视觉冲击力。

2、 First, the designer confirmed the design, selected processing materials.

首先草图, 效果图由设计师确认, 选定加工材料。

3、 According to the site, to determine the size of the sculpture. 根据现场, 图纸确定雕塑、摆件大小尺寸。

4、 Make mud draft, foam model, confirm the overall effect. 制作泥稿、泡沫模型, 确认整体效果。

5、 Indoor metal art material thickness shall not be less than 1.5 mm, resin thickness shall not be less than 3mm.

金属艺术品材料厚度室内不得低于1.5mm, 树脂厚度不得低于3mm。

6、 Resin artwork surface color guarantee does not fade. 树脂艺术品表面颜色保证不褪色。

7、 Seamless metal joints, bending polished smooth. 金属接缝处无缝隙, 折弯处打磨光滑。

8、 摆件雕塑必须牢固、稳定、安全、与灯光很好结合。

9、 石材基座必须做好加固, 以防碰撞引起倒塌。

10、 落地安放艺术品要稳、安全。

平面图

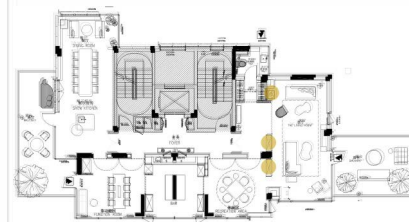

注: 1、实际艺术品以中标单位现场核实具体尺寸数量再深化为准;
2、此点位需灯光照亮, 需灯光顾问配合处理。

图片仅供参考, 以最终效果为准。

Project 项目名称: 杭州天目山格芮精选希尔顿酒店 Serial number 项目编号: PS-2F-6

Material 材质: 手绘艺术油画+黑色金属画框

Process description 工艺说明:

Area 区域: 独栋2F

Number 数量: 2件

Size 尺寸: W700*D30*H1000

独栋2F客厅

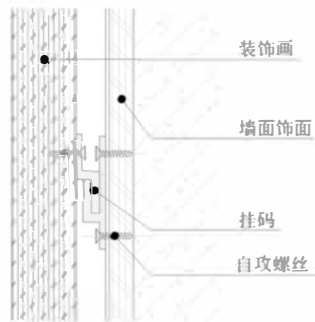
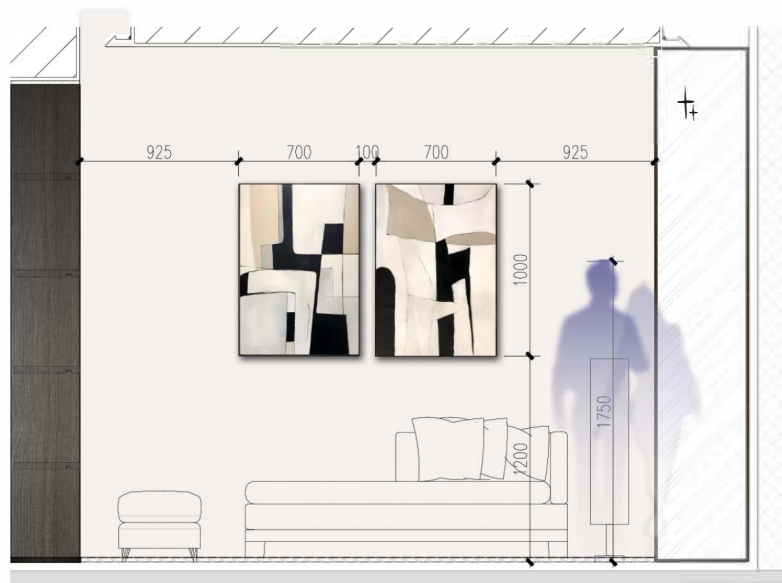

Furnishing articles and sculpture process requirements

摆件及雕塑工艺要求

1、 Art as the main theme, style, the main form of expression, need to have a strong visual impact

艺术品作为主题思想、风格的主要表现形式, 需要具有很强的视觉冲击力。

2、 First, the designer confirmed the design, selected processing materials.

首先草图, 效果图由设计师确认, 选定加工材料。

3、 According to the site, to determine the size of the sculpture. 根据现场, 图纸确定雕塑、摆件大小尺寸。

4、 Make mud draft, foam model, confirm the overall effect. 制作泥稿、泡沫模型, 确认整体效果。

5、 Indoor metal art material thickness shall not be less than 1.5 mm, resin thickness shall not be less than 3mm. 金属艺术品材料壁厚室内不得低于1.5mm,树脂壁厚不得低于3mm。

6、 Resin artwork surface color guarantee does not fade. 树脂艺术品表面颜色保证不褪色。

7、 Seamless metal joints, bending polished smooth. 金属接缝处无缝隙, 折弯处打磨光滑。

8、 摆件雕塑必须牢固、稳定、安全、与灯光很好结合。

9、 石材基座必须做好加重加固, 以防碰撞引起倒塌。

10、落地安放艺术品要稳、安全。

平面图

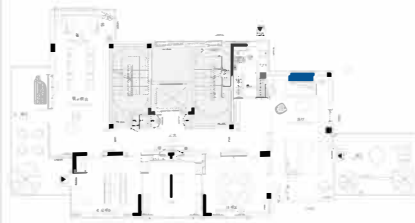

注: 1、实际艺术品以中标单位现场核实具体尺寸数量再深化为准;
2、此点位需灯光照亮, 需灯光顾问配合处理。

图片仅供参考, 以最终效果为准。

独栋2F餐厅



材质细节:



Furnishing articles and sculpture process requirements

摆件及雕塑工艺要求

- 1、 Art as the main theme, style, the main form of expression, need to have a strong visual impact
艺术品作为主题思想、风格的主要表现形式, 需要具有很强的视觉冲击力。
- 2、 First, the designer confirmed the design, selected processing materials.
首先草图, 效果图由设计师确认, 选定加工材料。
- 3、 According to the site, to determine the size of the sculpture. 根据现场, 图纸确定雕塑、摆件大小尺寸。
- 4、 Make mud draft, foam model, confirm the overall effect. 制作泥稿、泡沫模型, 确认整体效果。
- 5、 Indoor metal art material thickness shall not be less than 1.5 mm, resin thickness shall not be less than 3mm.
金属艺术品材料厚度室内不得低于1.5mm,树脂厚度不得低于3mm。
- 6、 Resin artwork surface color guarantee does not fade. 树脂艺术品表面颜色保证不褪色。
- 7、 Seamless metal joints, bending polished smooth. 金属接缝处无缝隙, 折弯处打磨光滑。
- 8、 摆件雕塑必须牢固、稳定、安全、与灯光很好结合。
- 9、 石材基座必须做好加重加固, 以防碰撞引起倒掉。
- 10、 落地安放艺术品要稳、安全。

安装示意:

灵感来源: 落叶

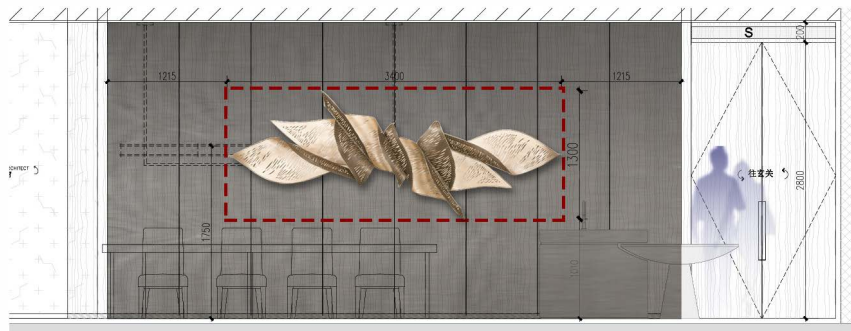
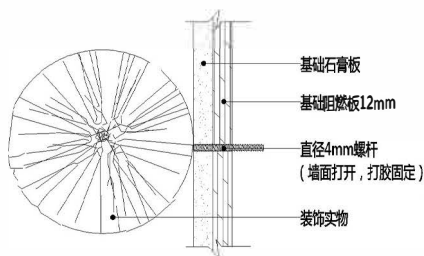

红框为加固区域;
需墙面加固厚度18mm木工板,
红框尺寸为W3500*H1400,加固范围尺寸如图所示。

平面图

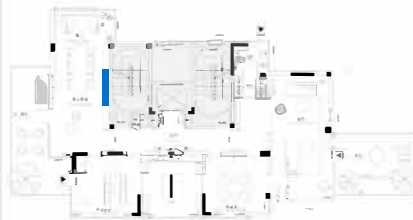

注: 1、实际艺术品以中标单位现场核实具体尺寸数量再深化为准;
2、此点位需灯光照亮, 需灯光顾问配合处理。

图片仅供参考, 以最终效果为准。

PS-3F-1

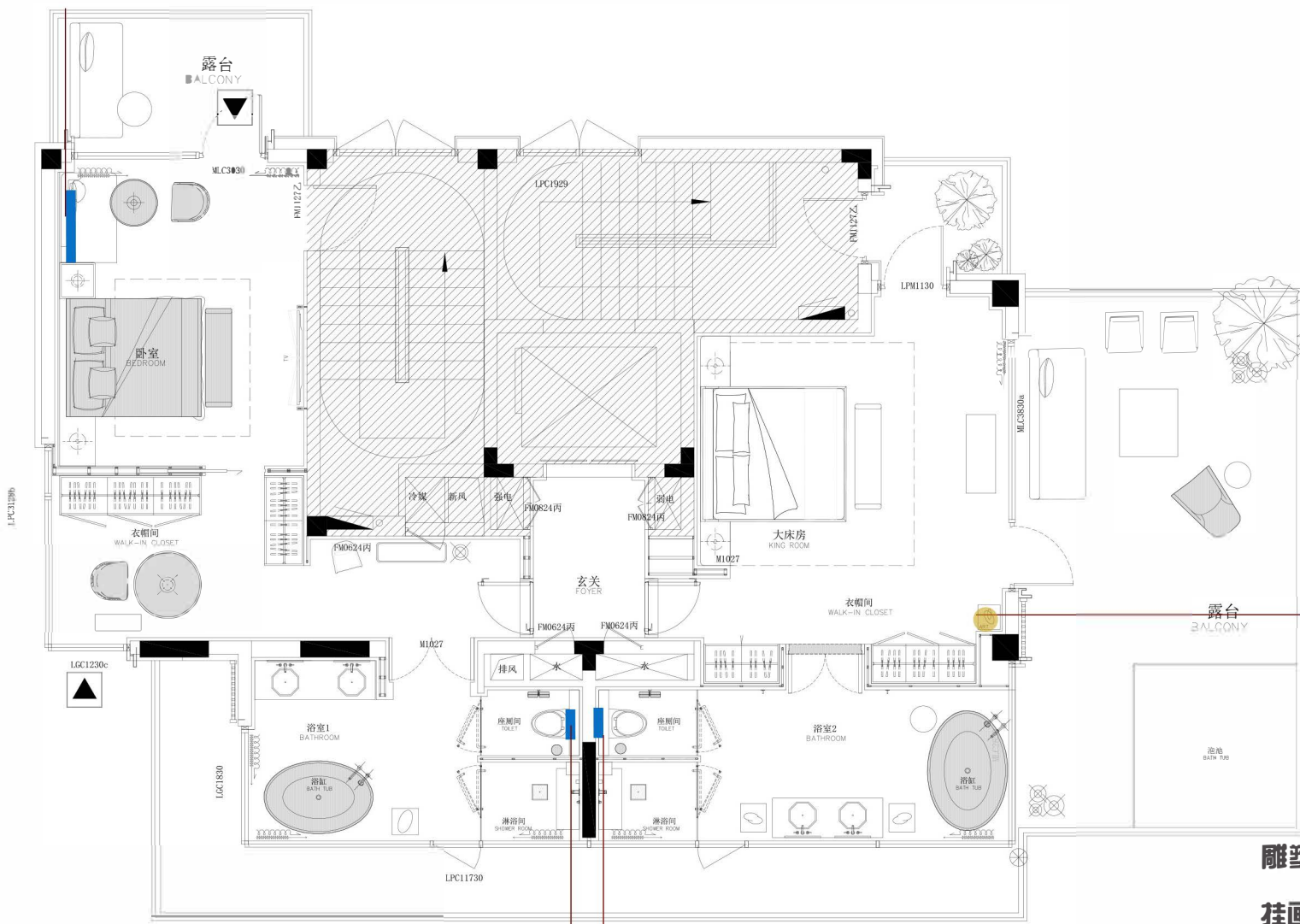

PS-3F-2

PS-3F-3

PS-3F-4

- | | | | |
|----|---|----|---|
| 雕塑 | ☆ | A级 | ● |
| 挂画 | ▭ | B级 | ● |
| 摆件 | ○ | C级 | ● |

独栋客房3F平面图

注：所有艺术品点位位置需要灯光配合

Project 项目名称: 杭州天目山格芮精选希尔顿酒店 Serial number 项目编号: PS-3F-1

Material 材质: 手绘艺术油画+黑色金属画框

Process description 工艺说明:

Area 区域: 客房

Number 数量: 1件

Size 尺寸: W700*D30*H700

独栋客房3F

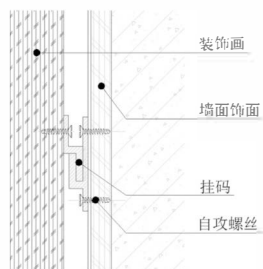
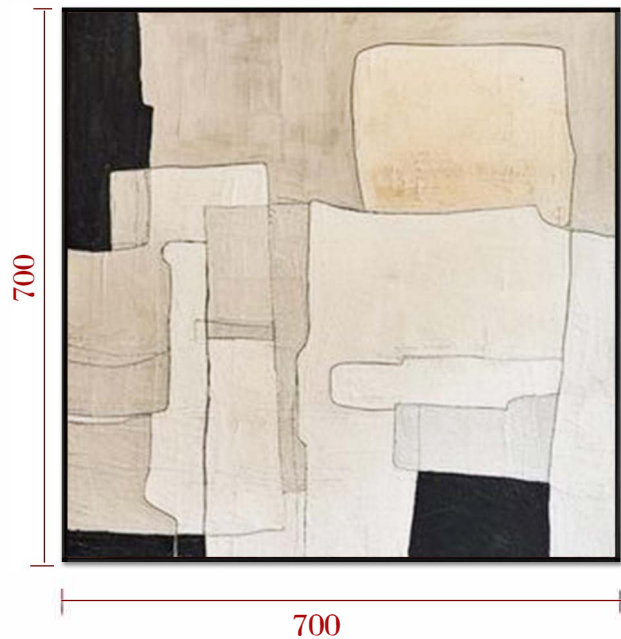

Furnishing articles and sculpture process requirements

摆件及雕塑工艺要求

- 1、 Art as the main theme, style, the main form of expression, need to have a strong visual impact
艺术品作为主题思想、风格的主要表现形式, 需要具有很强的视觉冲击力。
- 2、 First, the designer confirmed the design, selected processing materials.
首先草图, 效果图由设计师确认, 选定加工材料。
- 3、 According to the site, to determine the size of the sculpture.
根据现场, 图纸确定雕塑、摆件大小尺寸。
- 4、 Make mud draft, foam model, confirm the overall effect.
制作泥稿、泡沫模型, 确认整体效果。
- 5、 Indoor metal art material thickness shall not be less than 1.5 mm, resin thickness shall not be less than 3mm.
金属艺术品材料厚度室内不得低于1.5mm, 树脂艺术品材料厚度室内不得低于3mm。
- 6、 Resin artwork surface color guarantee does not fade.
树脂艺术品表面颜色保证不褪色。
- 7、 Seamless metal joints, bending polished smooth.
金属接缝处无缝隙, 折弯处打磨光滑。
- 8、 摆件雕塑必须牢固、稳定、安全、与灯光很好结合。
- 9、 石材基座必须做好加重加固, 以防碰撞引起倒掉。
- 10、 落地安放艺术品要稳、安全。

平面图

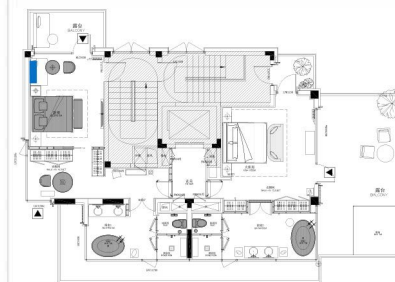

注: 1、实际艺术品以中标单位现场核实具体尺寸数量再深化为准;
2、此点位需灯光照亮, 需灯光顾问配合处理。

图片仅供参考, 以最终效果为准。

独栋客房3F



注: 1、实际艺术品以中标单位现场核实具体尺寸数量再深化为准;
2、此点位需灯光照亮, 需灯光顾问配合处理。

Furnishing articles and sculpture process requirements

摆件及雕塑工艺要求

- 1、Art as the main theme, style, the main form of expression, need to have a strong visual impact
艺术品作为主题思想、风格的主要表现形式, 需要具有很强的视觉冲击力。
- 2、First, the designer confirmed the design, selected processing materials.
首先草图, 效果图由设计师确认, 选定加工材料。
- 3、According to the site, to determine the size of the sculpture.
根据现场, 图纸确定雕塑、摆件大小尺寸。
- 4、Make mud draft, foam model, confirm the overall effect.
制作泥稿、泡沫模型, 确认整体效果。
- 5、Indoor metal art material thickness shall not be less than 1.5 mm, resin thickness shall not be less than 3mm.
金属艺术品材料厚度室内不得低于1.5mm, 树脂厚度不得低于3mm。
- 6、Resin artwork surface color guarantee does not fade.
树脂艺术品表面颜色保证不褪色。
- 7、Seamless metal joints, bending polished smooth.
金属接缝处无缝隙, 折弯处打磨光滑。
- 8、摆件雕塑必须牢固、稳定、安全、与灯光很好结合。
- 9、石材基座必须做好加重加固, 以防碰撞引起倒掉。
- 10、落地安放艺术品要稳、安全。

平面图

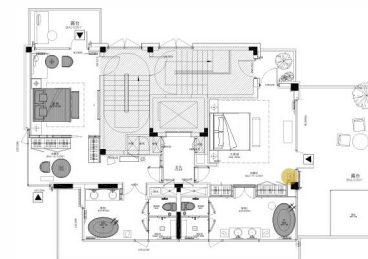

图片仅供参考, 以最终效果为准。

GR 02

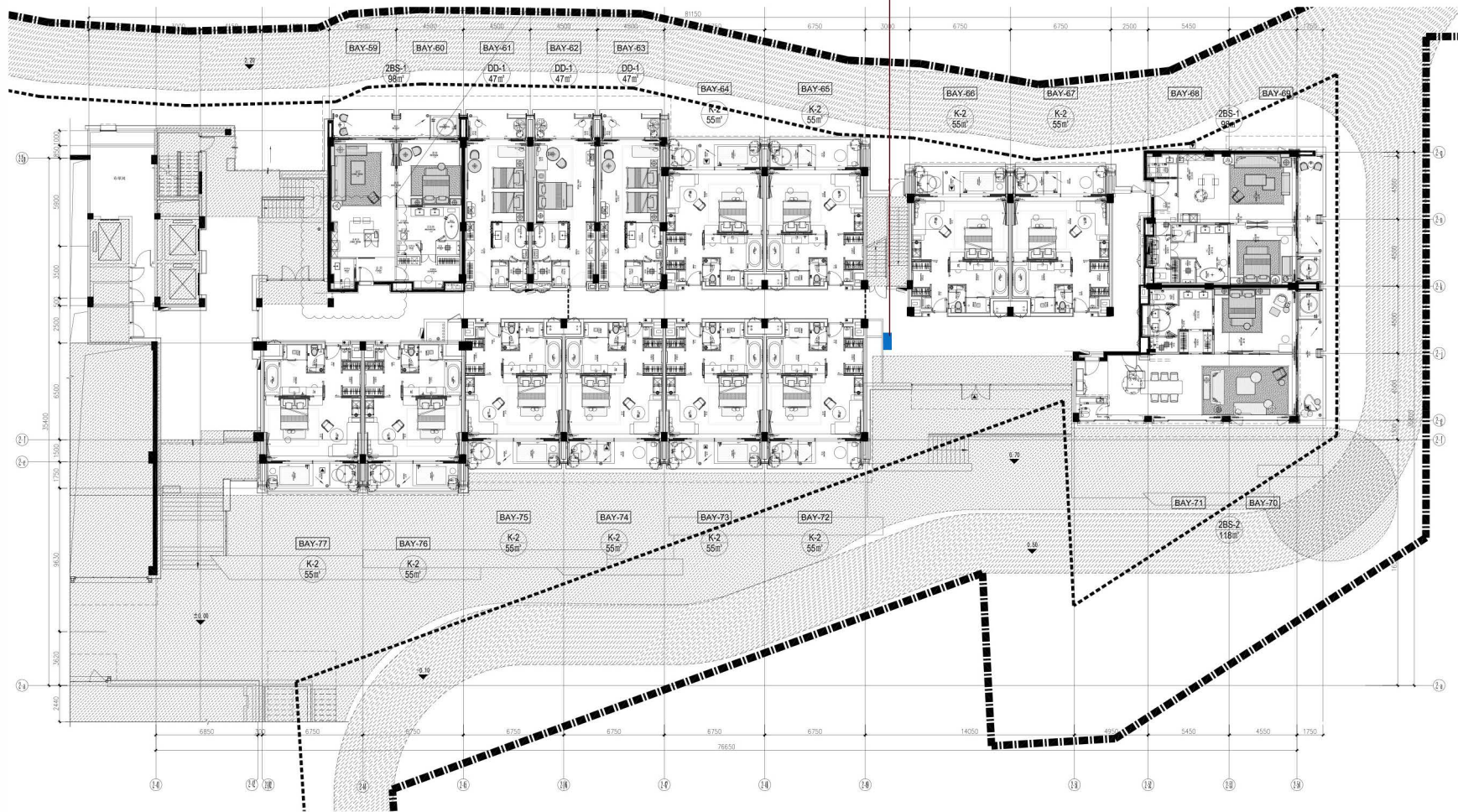

1F夹层客房平面图

- 挂画  A级 
- 雕塑  B级 
- 摆件  C级 

注：所有艺术品点位位置需要灯光配合

Room floor plan

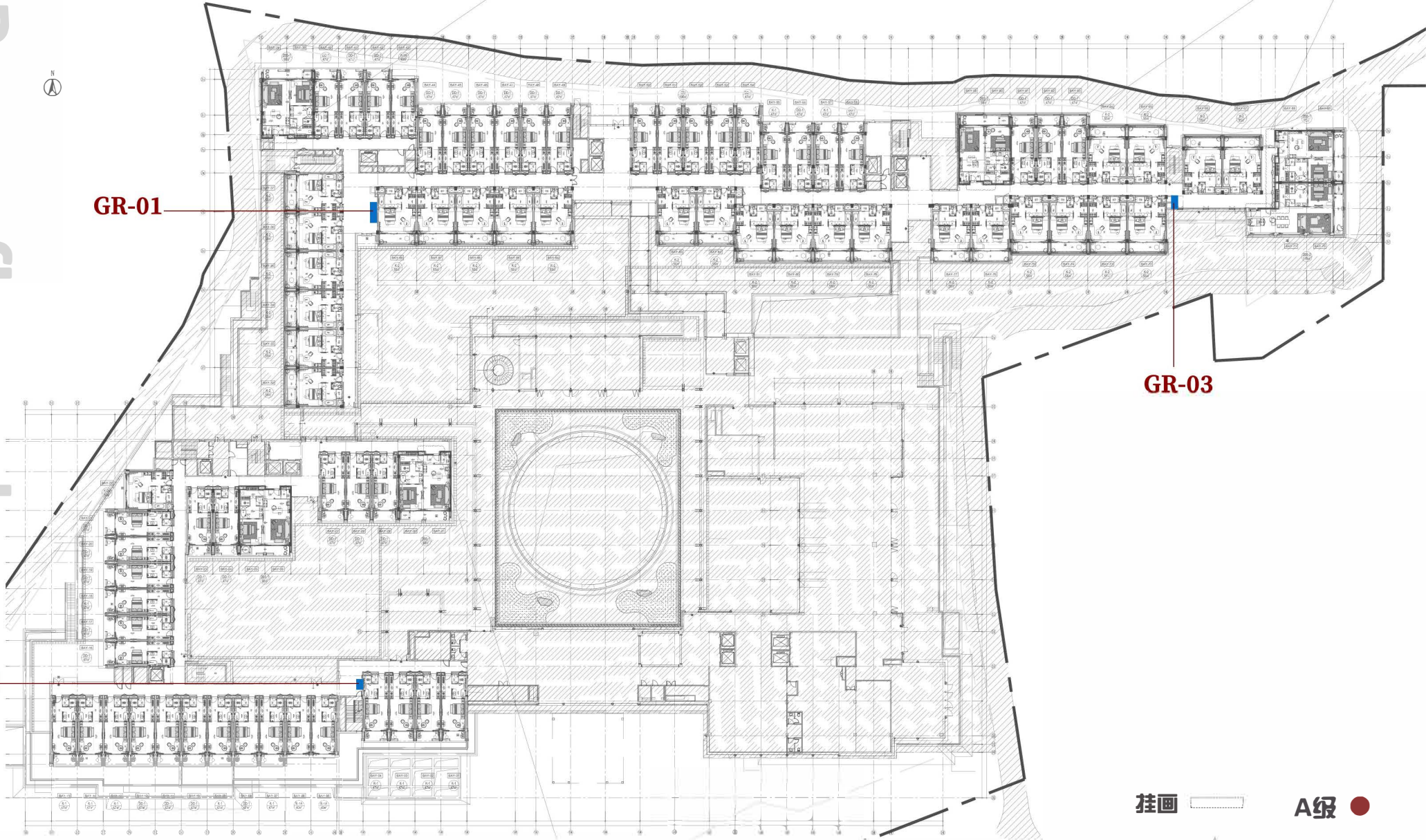

GR-02

GR-01

GR-03

2F客房平面图

- | | | | |
|----|--|----|--|
| 挂画 | | A级 | |
| 雕塑 | | B级 | |
| 摆件 | | C级 | |

注：所有艺术品点位位置需要灯光配合

Room floor plan

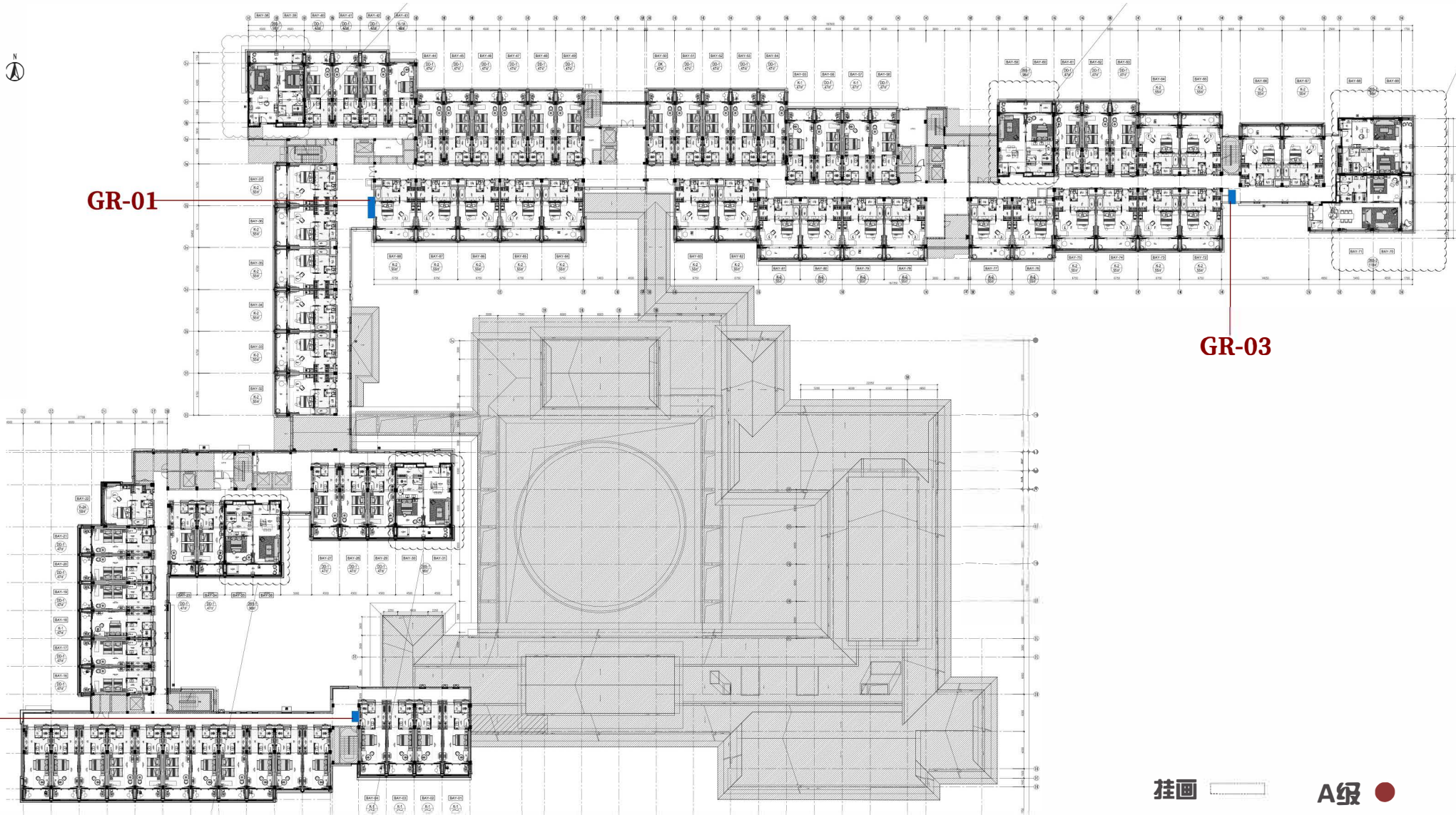

GR-02

GR-01

GR-03

3F客房平面图

- | | | | |
|----|---|----|---|
| 挂画 | ▭ | A级 | ● |
| 雕塑 | ☆ | B级 | ● |
| 摆件 | ○ | C级 | ● |

注：所有艺术品点位位置需要灯光配合

Room floor plan

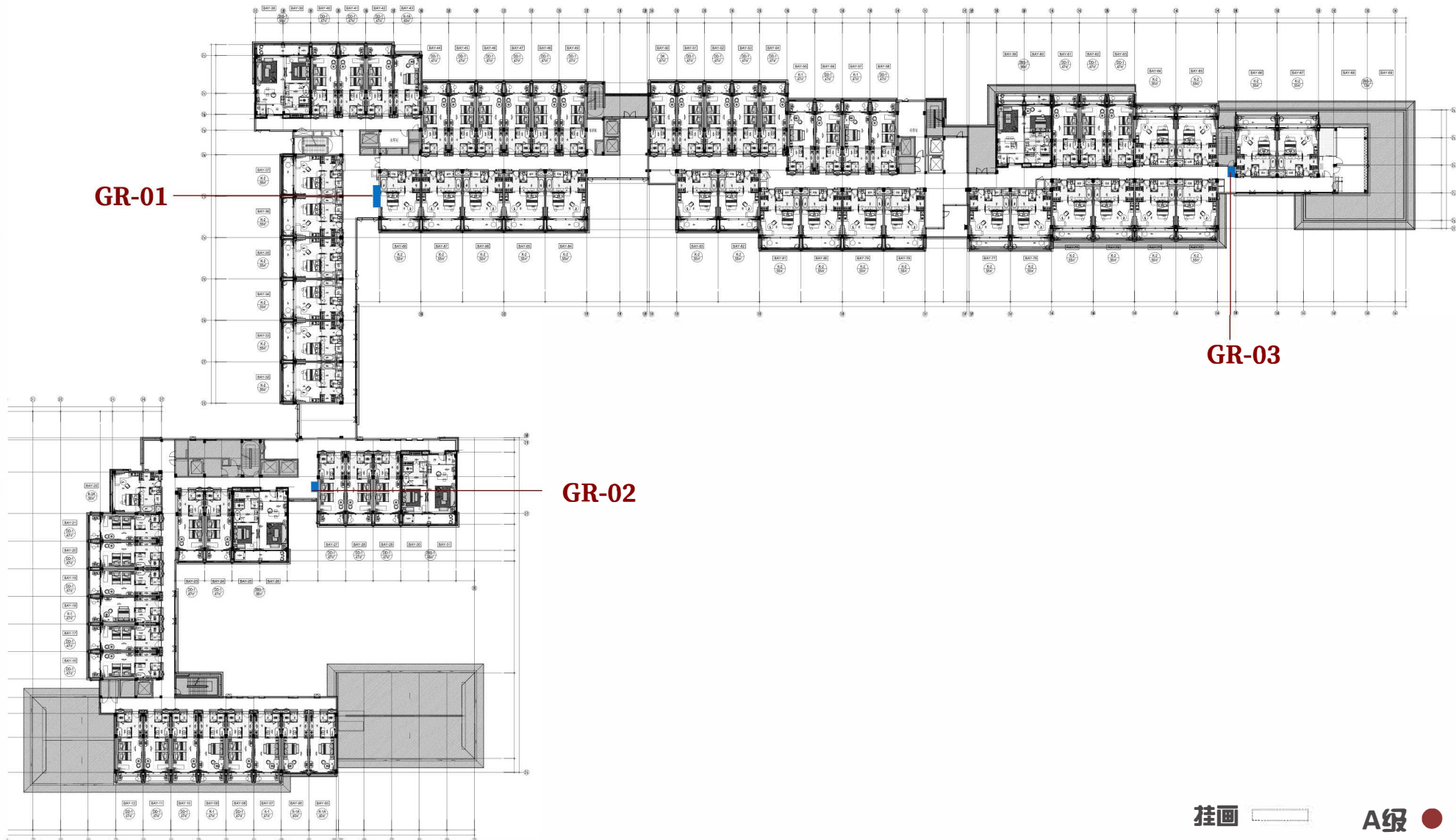







GR-01

GR-03

GR-02

4F客房平面图

- 挂画  A级 
- 雕塑  B级 
- 摆件  C级 

注：所有艺术品点位位置需要灯光配合

Room floor plan

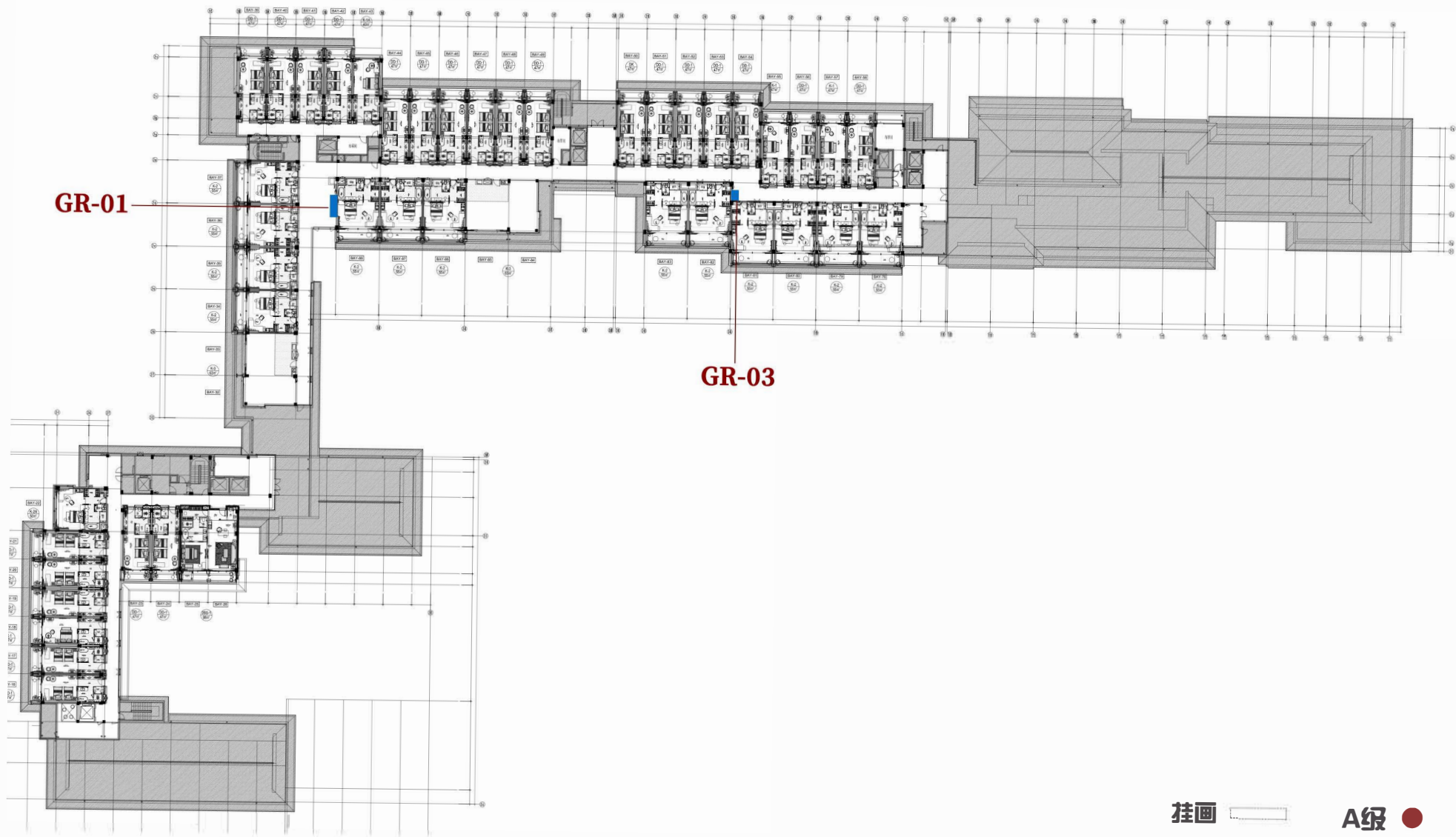

5F客房平面图

- | | | | |
|----|--|----|--|
| 挂画 | | A级 | |
| 雕塑 | | B级 | |
| 摆件 | | C级 | |

注：所有艺术品点位位置需要灯光配合



客房走道效果图

GUEST ROOM CORRIDOR RENDERINGS



客房电梯厅效果图

ROOM ELEVATOR HALL RENDERINGS

树叶摇曳

LEAVES SWAYING



阳光如缕缕金丝般穿过层层叠叠斑驳陆离的树叶，洋洋洒洒地倾落，
似是铺开了一地璀璨的金芒。那些珍稀树木的树叶，
宛如大自然倾尽心血雕琢而成的奇珍异宝。

THE SUNLIGHT PASSES THROUGH THE LAYERS OF MOTTLED LEAVES LIKE STRANDS
OF GOLDEN THREADS, AND FALLS FREELY,
IT SEEMED LIKE A BRIGHT GOLDEN LIGHT SPREAD OUT ALL OVER THE PLACE. THE
LEAVES OF THOSE RARE TREES,
IT IS LIKE A RARE TREASURE CARVED BY NATURE WITH ALL ITS EFFORTS.

当清风悠悠地拂过，树叶像是得到了某种神秘的召唤，迫不及待地挣脱
树枝的怀抱，踏上自由的旅程。渐渐地融化在这片诗意盎然的山林世界
里，与这片天地浑然一体，不分彼此。

WHEN THE BREEZE BLOWS LEISURELY, THE LEAVES SEEM TO HAVE RECEIVED SOME
MYSTERIOUS CALL, AND THEY CAN'T WAIT TO BREAK FREE FROM THE EMBRACE OF
THE BRANCHES AND EMBARK ON A JOURNEY OF FREEDOM. GRADUALLY MELTING
INTO THIS POETIC WORLD OF MOUNTAINS AND FORESTS, BECOMING ONE WITH THE
WORLD AND INSEPARABLE FROM EACH OTHER.

Project 项目名称: 杭州天目山格芮精选希尔顿酒店 Serial number 项目编号: GR-01

Material 材质: 手绘裂纹肌理+浇筑树脂+底部手绘画面+白色木框

Process description 工艺说明:

Area 区域: 客房走廊

Number 数量: 4件

Size 尺寸: W1300*D50*H1700

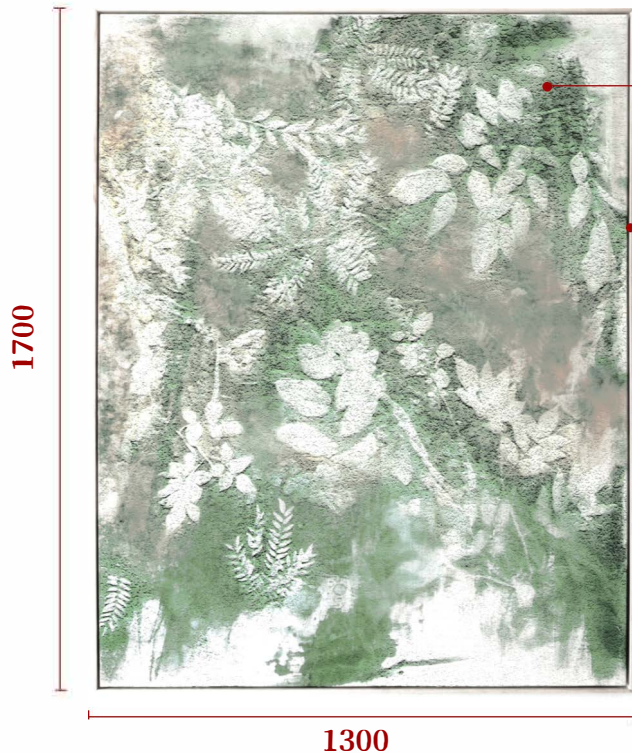

手绘裂纹肌理+浇筑树脂
+底部手绘画面

白色木框



材质细节



灵感来源: 树叶摇曳

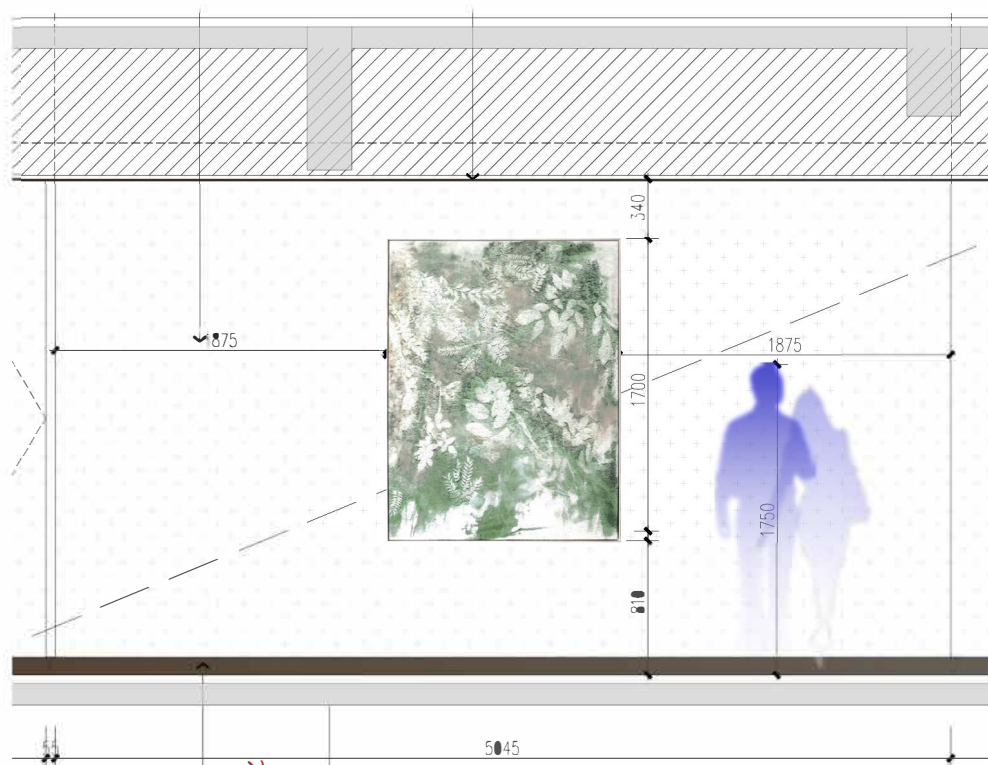

注:

- 1、实际艺术品以中标单位现场核实具体尺寸数量再深化为准;
- 2、此点位需灯光照亮,需灯光顾问配合处理。

Furnishing articles and sculpture process requirements

摆件及雕塑工艺要求

1、 Art as the main theme, style, the main form of expression, need to have a strong visual impact

艺术品作为主题思想、风格的主要表现形式,需要具有很强的视觉冲击力。

2、 First, the designer confirmed the design, selected processing materials.

首先草图,效果图由设计师确认,选定加工材料。

3、 According to the site, to determine the size of the sculpture. 根据现场,图纸确定雕塑、摆件大小尺寸。

4、 Make mud draft, foam model, confirm the overall effect. 制作泥稿、泡沫模型,确认整体效果。

5、 Indoor metal art material thickness shall not be less than 1.5 mm, resin thickness shall not be less than 3mm.

金属艺术品材料厚度室内不得低于1.5mm,树脂壁厚度不得低于3mm。

6、 Resin artwork surface color guarantee does not fade. 树脂艺术品表面颜色保证不褪色。

7、 Seamless metal joints, bending polished smooth. 金属接缝处无缝隙,折弯处打磨光滑。

8、 摆件雕塑必须牢固、稳定、安全、与灯光很好结合。

9、 石材基座必须做好加重加固,以防碰撞引起倒掉。

10、落地安放艺术品要稳、安全。

平面图

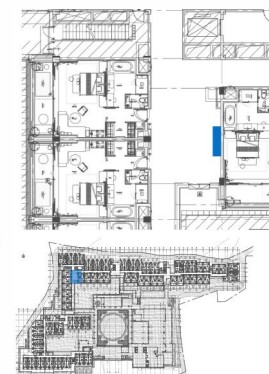

图片仅供参考,以最终效果为准。

当清风悠悠地拂过,树叶在空中肆意地旋转着、欢快地飘荡着,树影也紧跟着摇曳起来,时而清晰可辨,时而模糊朦胧,与那纷飞的树叶相互交织、缠绕,共同勾勒出一幅如梦如幻般令人沉醉的绝美画卷。用裂纹艺术肌理手法表现自然生态的原始纹理,表面浇筑树脂形式使画面增加一份神秘透亮感,充满艺术氛围。

WHEN THE BREEZE BLOWS LEISURELY, THE LEAVES ROTATE WANTONLY AND FLOAT HAPPILY IN THE AIR, AND THE TREE SHADOWS ALSO SWAY, SOMETIMES CLEARLY DISCERNIBLE, SOMETIMES BLURRY, INTERTWINED AND ENTWINED WITH THE FLYING LEAVES, AND TOGETHER THEY OUTLINE THE OUTLINE. A BEAUTIFUL PICTURE THAT IS AS INTOXICATING AS A DREAM. THE CRACK ART TEXTURE TECHNIQUE IS USED TO EXPRESS THE ORIGINAL TEXTURE OF NATURAL ECOLOGY, AND THE RESIN FORM Poured ON THE SURFACE ADDS A MYSTERIOUS AND TRANSLUCENT FEELING TO THE PICTURE, WHICH IS FULL OF ARTISTIC ATMOSPHERE.

Project 项目名称: 杭州天目山格芮精选希尔顿酒店 Serial number 项目编号: GR-02

Material 材质: 手绘裂纹肌理+浇筑树脂+底部手绘画面+白色木框

Process description 工艺说明:

Area 区域: 客房走廊

Number 数量: 4件

Size 尺寸: W1300*D50*H1700

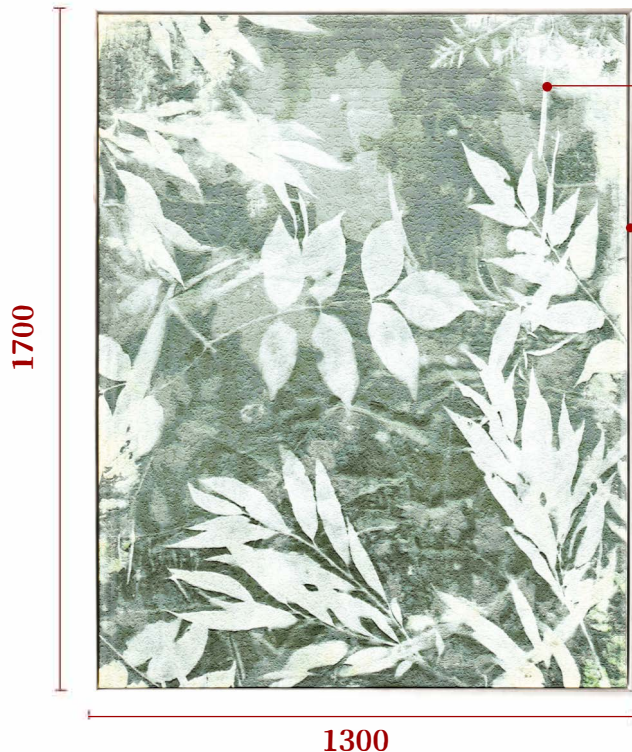

手绘裂纹肌理+浇筑树脂
+底部手绘画面

白色木框



材质细节



灵感来源: 树叶摇曳

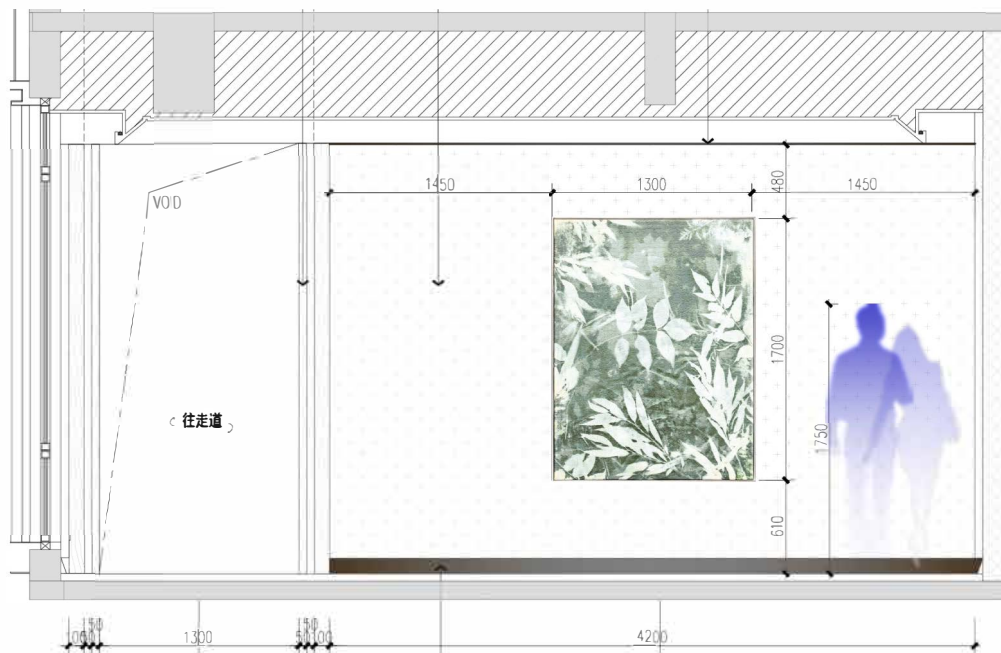

当清风悠悠地拂过,树叶在空中肆意地旋转着、欢快地飘荡着,树影也紧跟着摇曳起来,时而清晰可辨,时而模糊朦胧,与那纷飞的树叶相互交织、缠绕,共同勾勒出一幅如梦如幻般令人沉醉的绝美画卷。用裂纹艺术肌理手法表现自然生态的原始纹理,表面浇筑树脂形式使画面增加一份神秘透亮感,充满艺术氛围。

WHEN THE BREEZE BLOWS LEISURELY, THE LEAVES ROTATE WANTONLY AND FLOAT HAPPILY IN THE AIR, AND THE TREE SHADOWS ALSO SWAY, SOMETIMES CLEARLY DISCERNIBLE, SOMETIMES BLURRY, INTERTWINED AND ENTWINED WITH THE FLYING LEAVES, AND TOGETHER THEY OUTLINE THE OUTLINE. A BEAUTIFUL PICTURE THAT IS AS INTOXICATING AS A DREAM. THE CRACK ART TEXTURE TECHNIQUE IS USED TO EXPRESS THE ORIGINAL TEXTURE OF NATURAL ECOLOGY, AND THE RESIN FORM Poured ON THE SURFACE ADDS A MYSTERIOUS AND TRANSLUCENT FEELING TO THE PICTURE, WHICH IS FULL OF ARTISTIC ATMOSPHERE.

注:
1、实际艺术品以中标单位现场核实具体尺寸数量再深化为准;
2、此点位需灯光照亮,需灯光顾问配合处理。

Furnishing articles and sculpture process requirements

摆件及雕塑工艺要求

- 1、 Art as the main theme, style, the main form of expression, need to have a strong visual impact
艺术品作为主题思想、风格的主要表现形式,需要具有很强的视觉冲击力。
- 2、 First, the designer confirmed the design, selected processing materials.
首先草图,效果图由设计师确认,选定加工材料。
- 3、 According to the site, to determine the size of the sculpture.
根据现场,图纸确定雕塑、摆件大小尺寸。
- 4、 Make mud draft, foam model, confirm the overall effect.
制作泥稿、泡沫模型,确认整体效果。
- 5、 Indoor metal art material thickness shall not be less than 1.5 mm, resin thickness shall not be less than 3mm.
金属艺术品材料壁厚室内不得低于1.5mm,树脂壁厚不得低于3mm。
- 6、 Resin artwork surface color guarantee does not fade.
树脂艺术品表面颜色保证不褪色。
- 7、 Seamless metal joints, bending polished smooth.
金属接缝处无缝隙,折弯处打磨光滑。
- 8、 摆件雕塑必须牢固、稳定、安全、与灯光很好结合。
- 9、 石材基座必须做好加重加固,以防碰撞引起倒塌。
- 10、 落地安放艺术品要稳、安全。

平面图

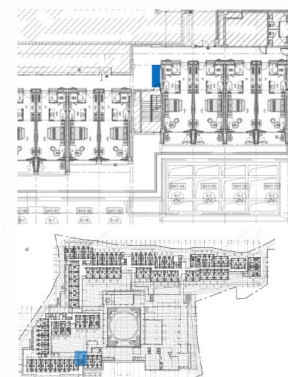

图片仅供参考,以最终效果为准。

Project 项目名称: 杭州天目山格芮精选希尔顿酒店 Serial number 项目编号: GR-03

Material 材质: 手绘裂纹肌理+浇筑树脂+底部手绘画面+白色木框

Process description 工艺说明:

Area 区域: 客房走廊

Number 数量: 4件

Size 尺寸: W1300*D50*H1700



手绘裂纹肌理+浇筑树脂
+底部手绘画面

白色木框

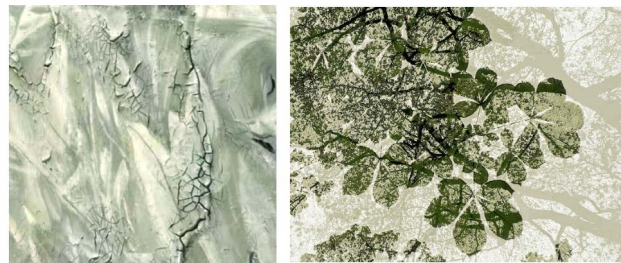

材质细节

灵感来源: 树叶摇曳

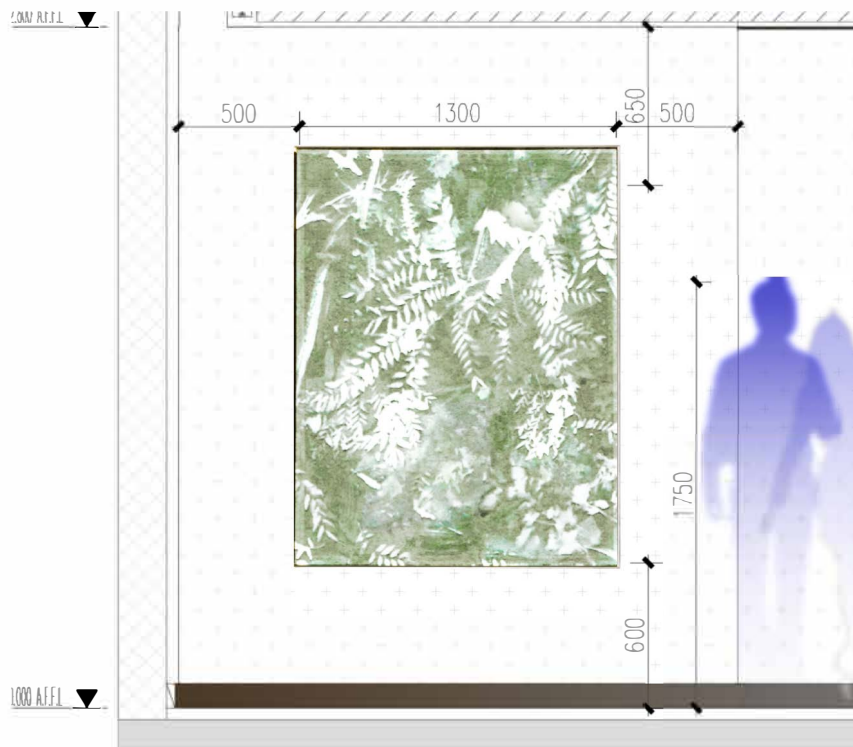

当清风悠悠地拂过,树叶在空中肆意地旋转着、欢快地飘荡着,树影也紧跟着摇曳起来,时而清晰可辨,时而模糊朦胧,与那纷飞的树叶相互交织、缠绕,共同勾勒出一幅如梦如幻般令人沉醉的绝美画卷。用裂纹艺术肌理手法表现自然生态的原始纹理,表面浇筑树脂形式使画面增加一份神秘透亮感,充满艺术氛围。

WHEN THE BREEZE BLOWS LEISURELY, THE LEAVES ROTATE WANTONLY AND FLOAT HAPPILY IN THE AIR, AND THE TREE SHADOWS ALSO SWAY, SOMETIMES CLEARLY DISCERNIBLE, SOME-TIMES BLURRY, INTERTWINED AND ENTWINED WITH THE FLYING LEAVES, AND TOGETHER THEY OUTLINE THE OUTLINE. A BEAUTIFUL PICTURE THAT IS AS INTOXICATING AS A DREAM. THE CRACK ART TEXTURE TECHNIQUE IS USED TO EXPRESS THE ORIGINAL TEXTURE OF NATURAL ECOLOGY, AND THE RESIN FORM POURED ON THE SURFACE ADDS A MYSTERIOUS AND TRAN-SLUENT FEELING TO THE PICTURE, WHICH IS FULL OF ARTISTIC ATMOSPHERE.

注:
1、实际艺术品以中标单位现场核实具体尺寸数量再深化为准;
2、此点位需灯光照亮,需灯光顾问配合处理。

Furnishing articles and sculpture process requirements

摆件及雕塑工艺要求

1、 Art as the main theme, style, the main form of expression, need to have a strong visual impact

艺术品作为主题思想、风格的主要表现形式,需要具有很强的视觉冲击力。

2、 First, the designer confirmed the design, selected processing materials.

首先草图,效果图由设计师确认,选定加工材料。

3、 According to the site, to determine the size of the sculpture. 根据现场,图纸确定雕塑、摆件大小尺寸。

4、 Make mud draft, foam model, confirm the overall effect. 制作泥稿、泡沫模型,确认整体效果。

5、 Indoor metal art material thickness shall not be less than 1.5 mm, resin thickness shall not be less than 3mm.

金属艺术品材料厚度室内不得低于1.5mm,树脂厚度不得不得低于3mm。

6、 Resin artwork surface color guarantee does not fade. 树脂艺术品表面颜色保证不褪色。

7、 Seamless metal joints, bending polished smooth. 金属接缝处无缝隙,折弯处打磨光滑。

8、 摆件雕塑必须牢固、稳定、安全、与灯光很好结合。

9、 石材基座必须做好加重加固,以防碰撞引起倒塌。

10、落地安放艺术品要稳、安全。

平面图

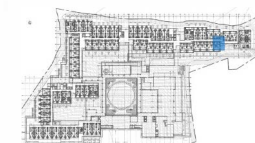
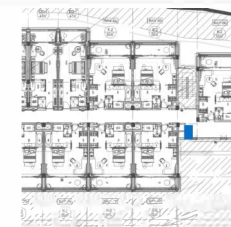

图片仅供参考,以最终效果为准。

FUNCTIONAL DIVISION

功能分区

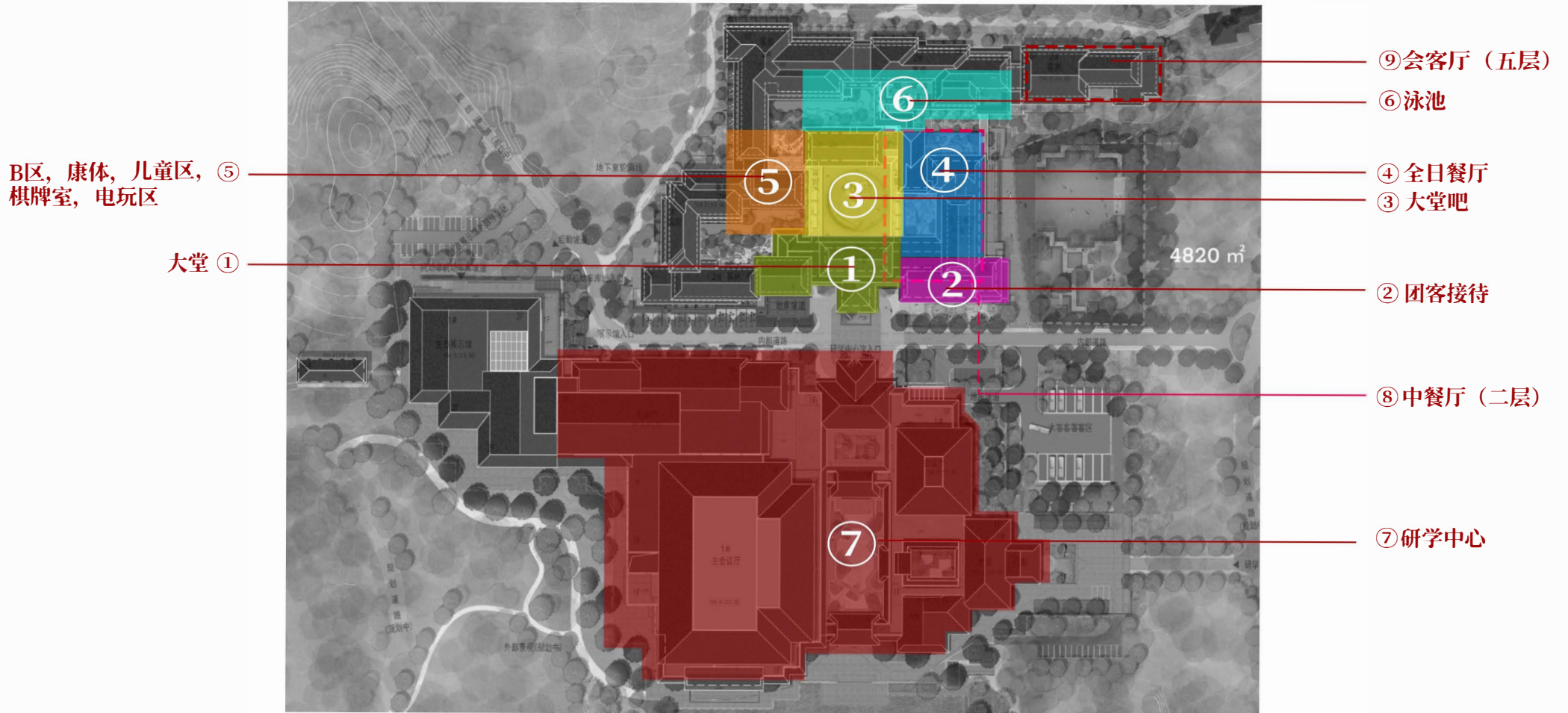

Room Mix-Max suite count
天目山希尔顿格芮酒店房型表

ROOM TYPE TABLE

房型表

FL/BAY	1	2	3	4	5	6	7	8	9	10	11	12	13	14	15	16	17	18	19	20	21	22	23	24	25	26	27	KEYS	FLOOR
5F																													
4F					K-1A	K-1A	K-1	DD-1	K-1	DD-1	DD-1	DD-1				DD-1	DD-1	K-1	DD-1	DD-1	K-2A	DD-1	DD-1	DD-1	2BS-1		10		
3F	K-1	K-1	K-1	K-1	K-1A	K-1A	K-1	DD-1	K-1	DD-1	DD-1	DD-1	K-1	K-1	K-1	DD-1	DD-1	K-1	DD-1	DD-1	K-2A	DD-1	DD-1	DD-1	2BS-1	DD-1	26		
2F	K-1	K-1	K-1	K-1	K-1A	K-1A	K-1	DD-1	K-1	DD-1	DD-1	DD-1	K-1	K-1	K-1	DD-1	DD-1	K-1	DD-1	DD-1	K-2A	DD-1	DD-1	DD-1	2BS-1	DD-1	26		
1F																													
	28	29	30	31	32	33	34	35	36	37	38	39	40	41	42	43	44	45	46	47	48	49	50	51	52	53	54		
5F					K-3		K-2	K-2	K-2	K-2	DD-1	DD-1	DD-1	DD-1	DD-1	K-1A	DD-1	DD-1	DD-1	DD-1	DD-1	DD-1	DD-1	DD-1	DD-1	DD-1	22		
4F	DD-1	DD-1	2BS-1		K-2	K-2	K-2	K-2	K-2	K-2	2BS-1	DD-1	DD-1	DD-1	K-1A	DD-1	DD-1	DD-1	DD-1	DD-1	DD-1	DD-1	DD-1	DD-1	DD-1	25			
3F	DD-1	DD-1	2BS-1		K-2	K-2	K-2	K-2	K-2	K-2	2BS-1	DD-1	DD-1	DD-1	K-1A	DD-1	DD-1	DD-1	DD-1	DD-1	DD-1	DD-1	DD-1	DD-1	DD-1	25			
2F	DD-1	DD-1	2BS-1		K-2	K-2	K-2	K-2	K-2	K-2	2BS-1	DD-1	DD-1	DD-1	K-1A	DD-1	DD-1	DD-1	DD-1	DD-1	DD-1	DD-1	DD-1	DD-1	DD-1	21			
1F																													
	55	56	57	58	59	60	61	62	63	64	65	66	67	68	69	70	71	72	73	74	75	76	77	78	79	80	81		
5F	K-1	DD-1	K-1	DD-1																							4		
4F	K-1	DD-1	K-1	DD-1	2BS-1	DD-1	DD-1	DD-1	K-2	K-2	K-2	K-2	2BS-3				K-2	K-2	K-2	K-2	K-2	K-2	K-2	K-2	K-2	K-2	23		
3F	K-1	DD-1	K-1	DD-1	2BS-1	DD-1	DD-1	DD-1	K-2	K-2	K-2	K-2	2BS-2				K-2	K-2	K-2	K-2	K-2	K-2	K-2	K-2	K-2	K-2	24		
2F	K-1	DD-1	K-1	DD-1	2BS-1	DD-1	DD-1	DD-1	K-2	K-2	K-2	K-2	2BS-1	2BS-2			K-2	K-2	K-2	K-2	K-2	K-2	K-2	K-2	K-2	K-2	24		
1F					2BS-1	DD-1	DD-1	DD-1	K-2	K-2	K-2	K-2	2BS-1	2BS-2			K-2	K-2	K-2	K-2	K-2	K-2	K-2	K-2	K-2	K-2	16		
	82	83	84	85	86	87	88																						
5F				K-3	K-2	K-2	K-2																				4		
4F	K-2	K-2	K-2	K-2	K-2	K-2	K-2																				7		
3F	K-2	K-2	K-2	K-2	K-2	K-2	K-2																				7		
2F	K-2	K-2	K-2	K-2	K-2	K-2	K-2																				7		
1F																											0		

THANK
YOU

谢谢观看