

STAINLESS STEEL SHOP DRAWING (CUSTOM)

不锈钢件生产要求图

Product Description (产品说明):	Goods rack
	货品支撑底架
Model Type (模具型号):	JFG4 A02

No:	Parts(零部件):	Material Specification(用料标准):
01	COUNTER TOP 柜台面	16GA. THK. SUS 304 S/S
02	LEG 支腿	∅38mm 16 GA. THK. SUS 304 S/S TUBE
03	ADJUSTABLE FOOT INSERT 可调节嵌入式底脚	LUI CHUEN KEE (CHN)
04	REINFORCEMENT 加固件	16 GA. THK. SUS 304 S/S
05	SINK BOWL 洗碗槽	16 GA. THK. SUS 304 S/S
06	SINK WASTE 废料槽	
07	S.S. CROSS RAIL 横梁	∅32mm 16 GA. THK. SUS 304 S/S TUBE
08	WALL MOUNTED BRACKET 壁装托架	16 GA. THK. SUS 304 S/S
√ 09	UNDER SHELF 底架	18 GA. THK. SUS 304 S/S
10	MIXING FAUCET 混合龙头	
11	OVER SHELF 顶架	18 GA. THK. SUS 304 S/S
12	OUTER DOOR PANEL 外板	20 GA. THK. SUS 304 S/S
13	INNER DOOR PANEL 内板	22 GA. THK. SUS 304 S/S
14	CABINET BODY 柜身	20 GA. THK. SUS 304 S/S
15	CORNER BUMPER 拐角防护套	COLSON (CHN)
16	SWIVEL CASTOR 旋转角轮	GLOBE (CHN)
17	SOUND DEADEN MATERIAL 隔音材料	3mm THICKNESS
18	WALL FLASHING 防水面	20 GA. THK. SUS 304 S/S
19	CONDENSING UNIT 制冷机组	DANFOSS (CHN)
20	NOZZLE 排气口	∅25mm SUS 304 S/S TUBE

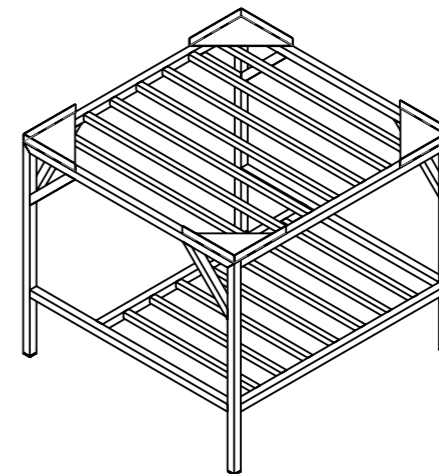
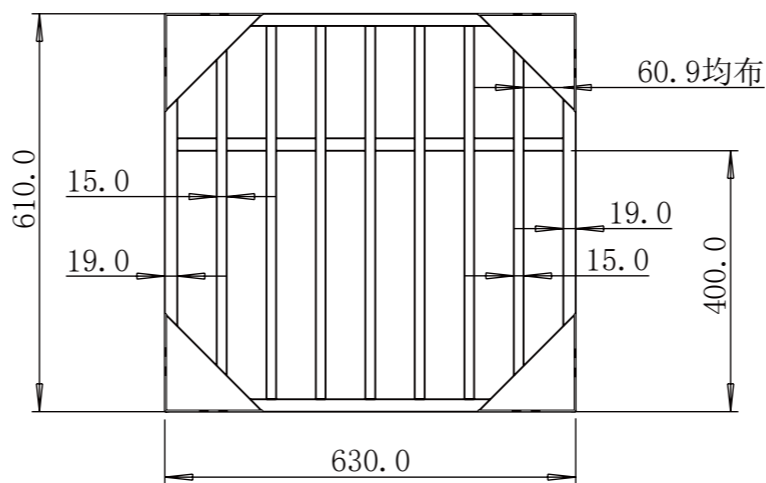
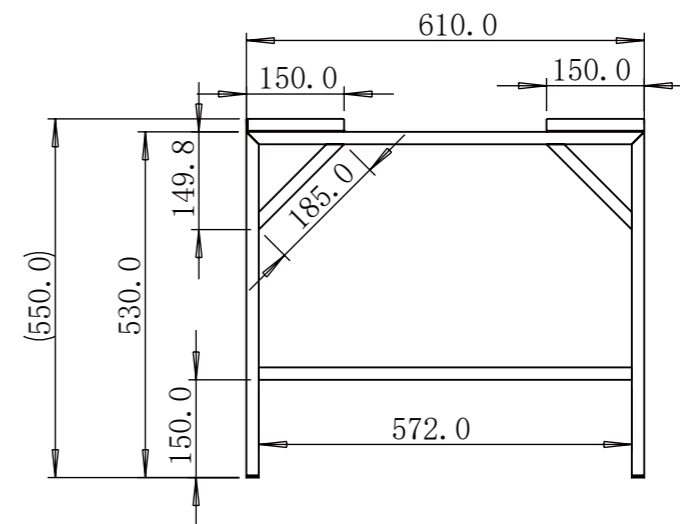
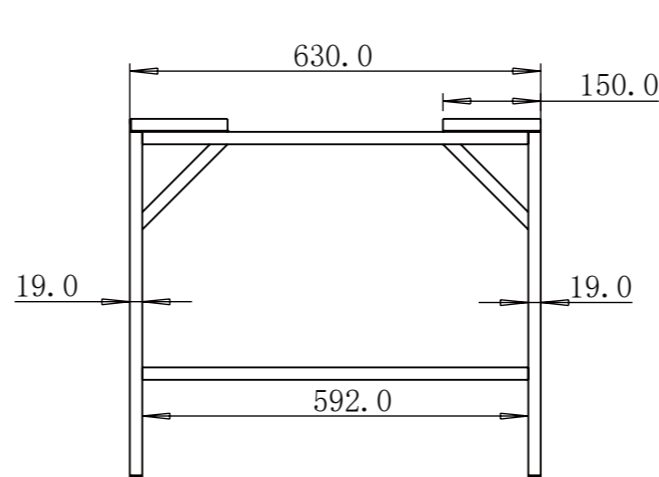

No:	Item No(款号):	Qty(数量):	No:	Item No(款号):	Qty(数量):

Remark(备注):



M5

SPOT WELDED A THREADED SHAFT TO THE UNDERSIDE OF WORK TOP / SHELF. THEN USE UNITS TO FIX WITH THE REINFORCEMENT / BRACKETS

技术说明:

- 1.所有产品边缘不能有毛刺, 覆膜面不能刮花;
- 2.公差要求标准: 符合GB/T G3280-2015不锈钢冷轧钢板和钢带标准中PT.A的公称宽度要求;
- 3.所有标注尺寸为外尺寸;
- 4.未注膜面方向朝外。

SKU:

名称: 建德C40+潜水俱乐部厨房

材料:

编制:

审核:

日期:

日期:

视角:

版本:



A

STAINLESS STEEL SHOP DRAWING (CUSTOM)

不锈钢件生产要求图

Product Description (产品说明):	4-Tier Square Tube Storage Shelving
	四层平板货架
Model Type (模具型号):	JFG4 A02

No:	Parts(零部件):	Material Specification(用料标准):
01	COUNTER TOP 柜台面	16GA. THK. SUS 304 S/S
✓ 02	LEG 支腿	∅38mm 16 GA. THK. SUS 304 S/S TUBE
✓ 03	ADJUSTABLE FOOT INSERT 可调节嵌入式底脚	LUI CHUEN KEE (CHN)
04	REINFORCEMENT 加固件	16 GA. THK. SUS 304 S/S
05	SINK BOWL 洗碗槽	16 GA. THK. SUS 304 S/S
06	SINK WASTE 废料槽	
✓ 07	S.S. CROSS RAIL 横梁	∅32mm 16 GA. THK. SUS 304 S/S TUBE
08	WALL MOUNTED BRACKET 壁装托架	16 GA. THK. SUS 304 S/S
09	UNDER SHELF 底架	18 GA. THK. SUS 304 S/S
10	MIXING FAUCET 混合龙头	
11	OVER SHELF 顶架	18 GA. THK. SUS 304 S/S
12	OUTER DOOR PANEL 外板	20 GA. THK. SUS 304 S/S
13	INNER DOOR PANEL 内板	22 GA. THK. SUS 304 S/S
14	CABINET BODY 柜身	20 GA. THK. SUS 304 S/S
15	CORNER BUMPER 拐角防护套	COLSON (CHN)
16	SWIVEL CASTOR 旋转角轮	GLOBE (CHN)
17	SOUND DEADEN MATERIAL 隔音材料	3mm THICKNESS
18	WALL FLASHING 防水面	20 GA. THK. SUS 304 S/S
19	CONDENSING UNIT 制冷机组	DANFOSS (CHN)
20	NOZZLE 排气口	∅25mm SUS 304 S/S TUBE

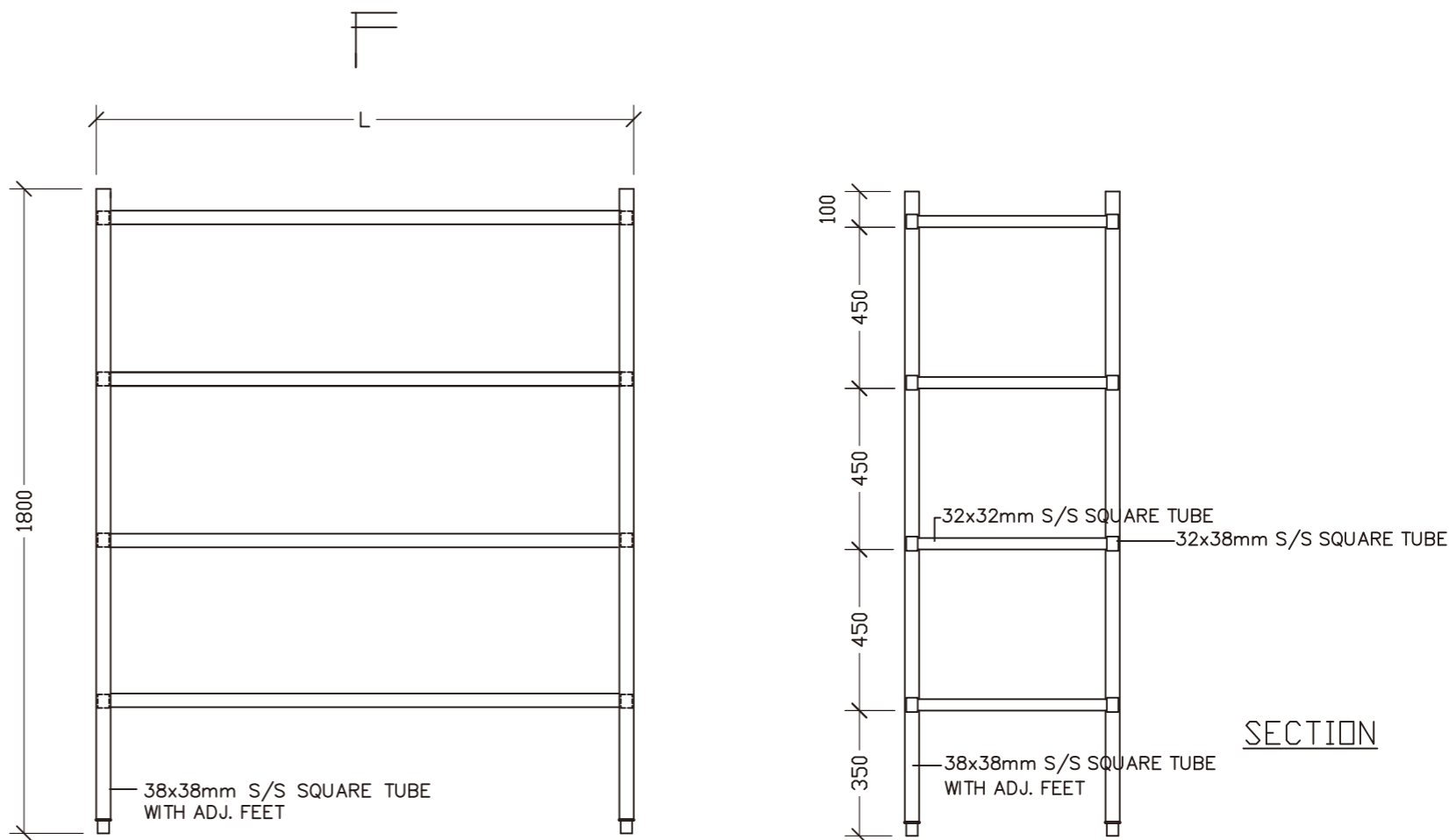

No:	Item No(款号):	Qty(数量):	No:	Item No(款号):	Qty(数量):

Remark(备注):



M5

SPOT WELDED A THREADED SHAFT TO THE UNDERSIDE OF WORK TOP / SHELF. THEN USE UNITS TO FIX WITH THE REINFORCEMENT / BRACKETS

ELEVATION

PLAN

SECTION

技术说明:				SKU:			
1.所有产品边缘不能有毛刺, 覆膜面不能刮花;				名称:	建德C40+潜水俱乐部厨房		
2.公差要求标准: 符合GB/T G3280-2015不锈钢冷轧钢板和钢带标准中PT.A的公称宽度要求;				材料:			
3.所有标注尺寸为外尺寸;				编制:		日期:	
4.未注膜面方向朝外。				审核:		日期:	
A						视角:	☉
版本		批准	日期			版本:	A

STAINLESS STEEL SHOP DRAWING (CUSTOM)

不锈钢件生产要求图

Product Description (产品说明):	Cabinet W/Single Sink & Waste Bin
	单星盆柜连垃圾筒柜
Model Type (模具型号):	SBSH115 B01

No:	Parts(零部件):	Material Specification(用料标准):
✓ 01	COUNTER TOP 柜台面	16GA. THK. SUS 304 S/S
02	LEG 支腿	∅38mm 16 GA. THK. SUS 304 S/S TUBE
✓ 03	ADJUSTABLE FOOT INSERT 可调节嵌入式底脚	LUI CHUEN KEE (CHN)
✓ 04	REINFORCEMENT 加固件	16 GA. THK. SUS 304 S/S
05	SINK BOWL 洗碗槽	16 GA. THK. SUS 304 S/S
✓ 06	SINK WASTE 废料槽	
07	S.S. CROSS RAIL 横梁	∅32mm 16 GA. THK. SUS 304 S/S TUBE
08	WALL MOUNTED BRACKET 壁装托架	16 GA. THK. SUS 304 S/S
09	UNDER SHELF 底架	18 GA. THK. SUS 304 S/S
10	MIXING FAUCET 混合龙头	
11	OVER SHELF 顶架	18 GA. THK. SUS 304 S/S
✓ 12	OUTER DOOR PANEL 外板	20 GA. THK. SUS 304 S/S
✓ 13	INNER DOOR PANEL 内板	22 GA. THK. SUS 304 S/S
✓ 14	CABINET BODY 柜身	20 GA. THK. SUS 304 S/S
15	CORNER BUMPER 拐角防护套	COLSON (CHN)
16	SWIVEL CASTOR 旋转角轮	GLOBE (CHN)
17	SOUND DEADEN MATERIAL 隔音材料	3mm THICKNESS
18	WALL FLASHING 防水面	20 GA. THK. SUS 304 S/S
19	CONDENSING UNIT 制冷机组	DANFOSS (CHN)
20	NOZZLE 排气口	∅25mm SUS 304 S/S TUBE

No:	Item No(款号):	Qty(数量):	No:	Item No(款号):	Qty(数量):

Remark(备注):	
 M5	SPOT WELDED A THREADED SHAFT TO THE UNDERSIDE OF WORK TOP / SHELF. THEN USE UNITS TO FIX WITH THE REINFORCEMENT / BRACKETS

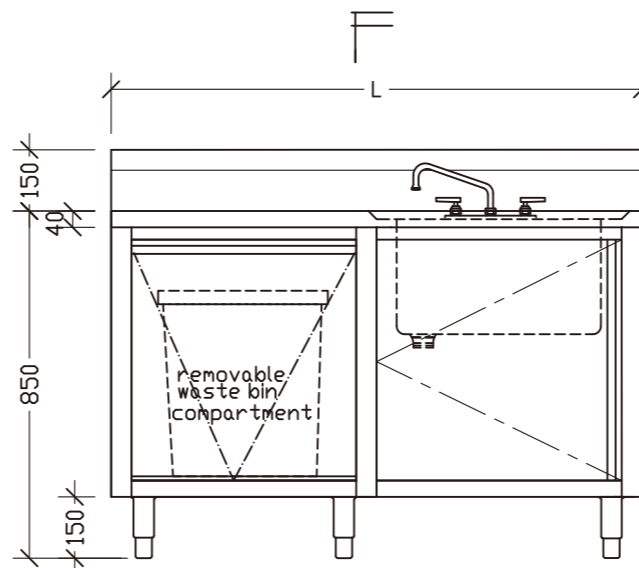

ELEVATION

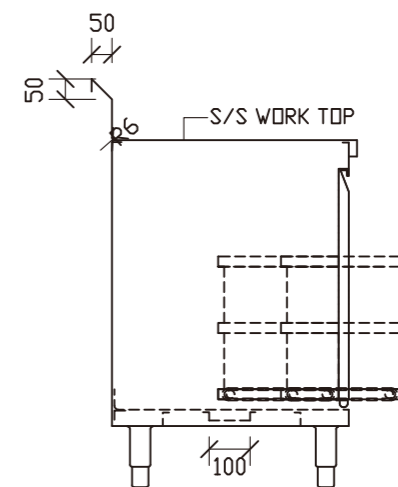

SECTION

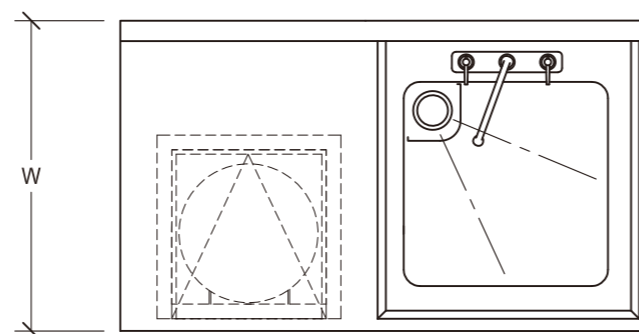

PLAN

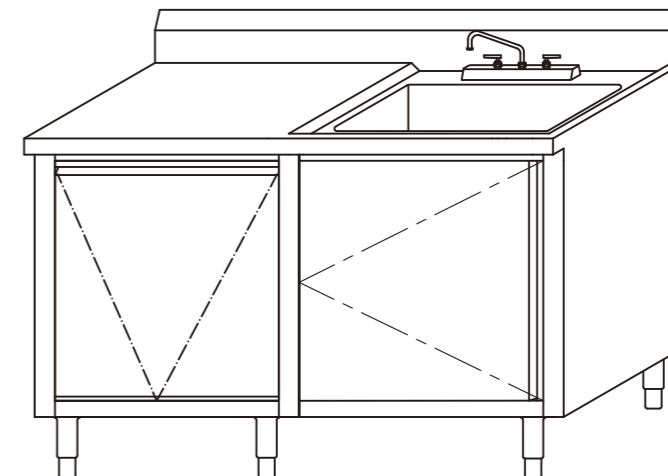

ISOMETRIC VIEW

技术说明:				SKU:			
1.所有产品边缘不能有毛刺, 覆膜面不能刮花;				名称:	建德C40+潜水俱乐部厨房		
2.公差要求标准: 符合GB/T G3280-2015不锈钢冷轧钢板和钢带标准中PT.A的公称宽度要求;				材料:			
3.所有标注尺寸为外尺寸;				编制:		日期:	
4.未注膜面方向朝外。				审核:		日期:	
A						视角:	
版本		批准	日期			版本:	A

STAINLESS STEEL SHOP DRAWING (CUSTOM)

不锈钢件生产要求图

Product Description (产品说明):	Hand Wash Sink
	挂墙洗手星盆
Model Type (模具型号):	SHSC1-W B03

No:	Parts(零部件):	Material Specfication(用料标准):
✓ 01	COUNTER TOP 柜台面	16GA. THK. SUS 304 S/S
02	LEG 支腿	∅38mm 16 GA. THK. SUS 304 S/S TUBE
03	ADJUSTABLE FOOT INSERT 可调节嵌入式底脚	LUI CHUEN KEE (CHN)
✓ 04	REINFORCEMENT 加固件	16 GA. THK. SUS 304 S/S
✓ 05	SINK BOWL 洗碗槽	16 GA. THK. SUS 304 S/S
06	SINK WASTE 废料槽	
07	S.S. CROSS RAIL 横梁	∅32mm 16 GA. THK. SUS 304 S/S TUBE
✓ 08	WALL MOUNTED BRACKET 壁装托架	16 GA. THK. SUS 304 S/S
09	UNDER SHELF 底架	18 GA. THK. SUS 304 S/S
✓ 10	MIXING FAUCET 混合龙头	
11	OVER SHELF 顶架	18 GA. THK. SUS 304 S/S
12	OUTER DOOR PANEL 外板	20 GA. THK. SUS 304 S/S
13	INNER DOOR PANEL 内板	22 GA. THK. SUS 304 S/S
14	CABINET BODY 柜身	20 GA. THK. SUS 304 S/S
15	CORNER BUMPER 拐角防护套	COLSON (CHN)
16	SWIVEL CASTOR 旋转角轮	GLOBE (CHN)
17	SOUND DEADEN MATERIAL 隔音材料	3mm THICKNESS
18	WALL FLASHING 防水面	20 GA. THK. SUS 304 S/S
19	CONDENSING UNIT 制冷机组	DANFOSS (CHN)
20	NOZZLE 排气口	∅25mm SUS 304 S/S TUBE

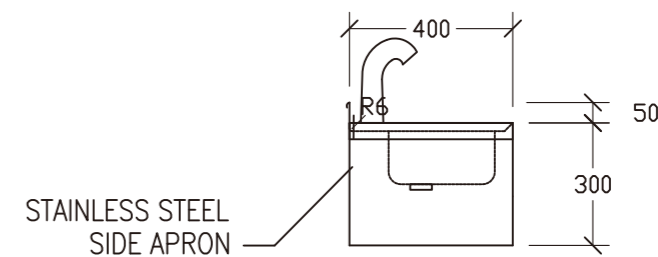
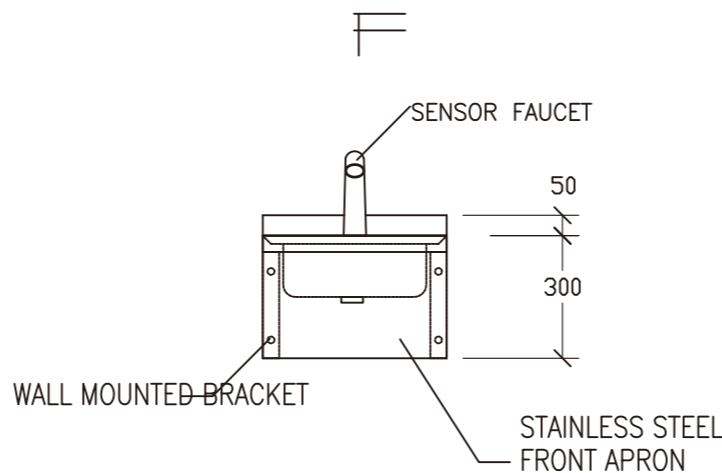

ELEVATION

SECTION

No:	Item No(款号):	Qty(数量):	No:	Item No(款号):	Qty(数量):

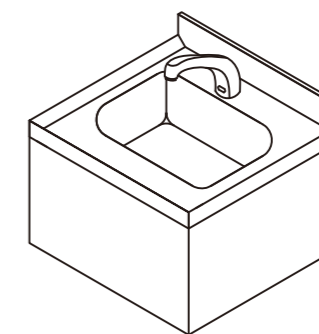
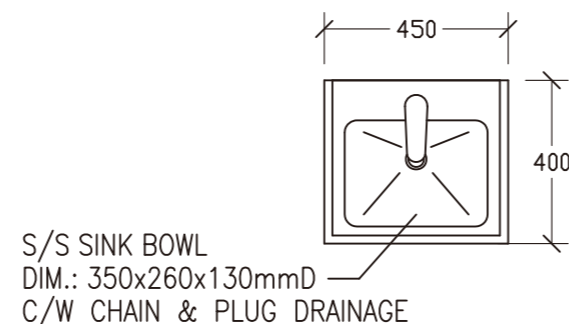

Remark(备注):



SPOT WELDED A THREADED SHAFT TO THE UNDERSIDE OF WORK TOP / SHELF. THEN USE UNITS TO FIX WITH THE REINFORCEMENT / BRACKETS

技术说明:				SKU:			
1.所有产品边缘不能有毛刺, 覆膜面不能刮花;				名称:	建德C40+潜水俱乐部厨房		
2.公差要求标准: 符合GB/T G3280-2015不锈钢冷轧钢板和钢带标准中PT.A的公称宽度要求;				材料:			
3.所有标注尺寸为外尺寸;				编制:		日期:	
4.未注膜面方向朝外。				审核:		日期:	
A						视角:	☉
版本		批准	日期			版本:	A

STAINLESS STEEL SHOP DRAWING (CUSTOM)

不锈钢件生产要求图

Product Description (产品说明):	Work Cabinet
	单向调理台柜
Model Type (模具型号):	CBH B05

No:	Parts(零部件):	Material Specification(用料标准):
✓ 01	COUNTER TOP 柜台面	16GA. THK. SUS 304 S/S
02	LEG 支腿	Ø38mm 16 GA. THK. SUS 304 S/S TUBE
✓ 03	ADJUSTABLE FOOT INSERT 可调节嵌入式底脚	LUI CHUEN KEE (CHN)
✓ 04	REINFORCEMENT 加固件	16 GA. THK. SUS 304 S/S
05	SINK BOWL 洗碗槽	16 GA. THK. SUS 304 S/S
06	SINK WASTE 废料槽	
07	S.S. CROSS RAIL 横梁	Ø32mm 16 GA. THK. SUS 304 S/S TUBE
08	WALL MOUNTED BRACKET 壁装托架	16 GA. THK. SUS 304 S/S
✓ 09	UNDER SHELF 底架	18 GA. THK. SUS 304 S/S
10	MIXING FAUCET 混合龙头	
11	OVER SHELF 顶架	18 GA. THK. SUS 304 S/S
✓ 12	OUTER DOOR PANEL 外板	20 GA. THK. SUS 304 S/S
✓ 13	INNER DOOR PANEL 内板	22 GA. THK. SUS 304 S/S
✓ 14	CABINET BODY 柜身	20 GA. THK. SUS 304 S/S
15	CORNER BUMPER 拐角防护套	COLSON (CHN)
16	SWIVEL CASTOR 旋转角轮	GLOBE (CHN)
17	SOUND DEADEN MATERIAL 隔音材料	3mm THICKNESS
18	WALL FLASHING 防水面	20 GA. THK. SUS 304 S/S
19	CONDENSING UNIT 制冷机组	DANFOSS (CHN)
20	NOZZLE 排气口	Ø25mm SUS 304 S/S TUBE

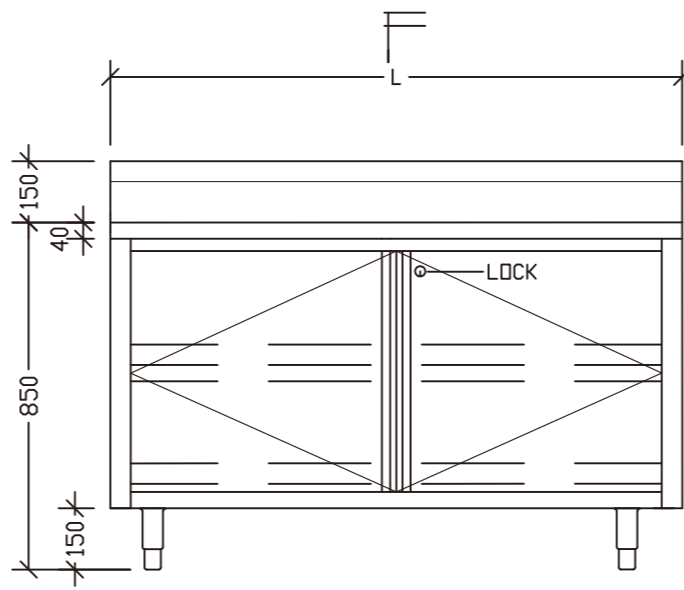

ELEVATION

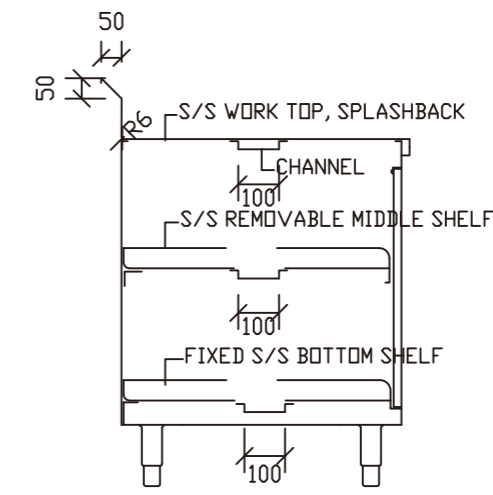

SECTION

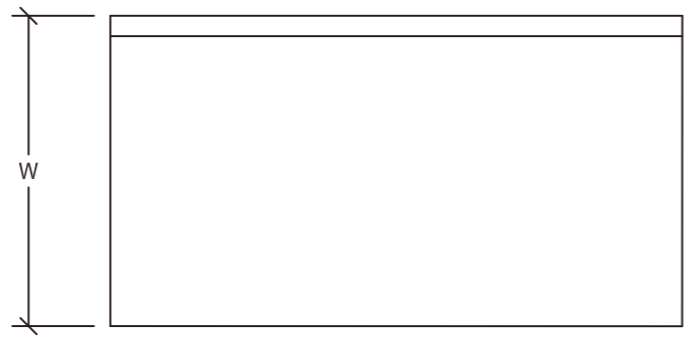

PLAN

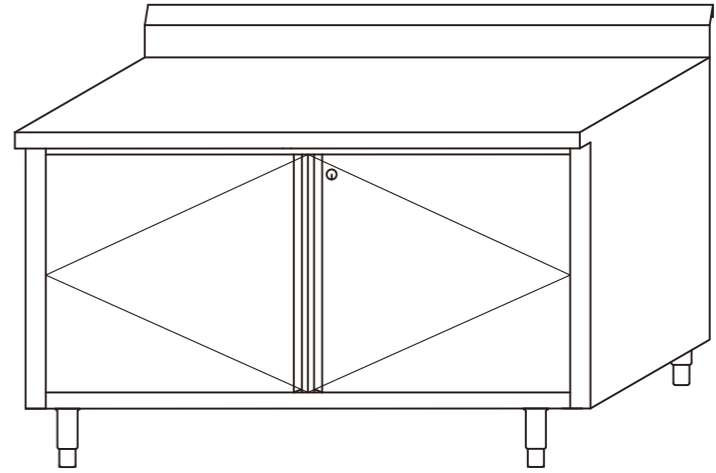

ISOMETRIC VIEW

No:	Item No(款号):	Qty(数量):	No:	Item No(款号):	Qty(数量):

Remark(备注):



SPOT WELDED A THREADED SHAFT TO THE UNDERSIDE OF WORK TOP / SHELF. THEN USE UNITS TO FIX WITH THE REINFORCEMENT / BRACKETS

技术说明:				SKU:			
1.所有产品边缘不能有毛刺, 覆膜面不能刮花;				名称:	建德C40+潜水俱乐部厨房		
2.公差要求标准: 符合GB/T G3280-2015不锈钢冷轧钢板和钢带标准中PT.A的公称宽度要求;				材料:			
3.所有标注尺寸为外尺寸;				编制:		日期:	
4.未注膜面方向朝外。				审核:		日期:	
A						视角:	☉
版本			批准	日期		版本:	A

STAINLESS STEEL SHOP DRAWING (CUSTOM)

不锈钢件生产要求图

Product Description (产品说明):	Hand Wash Sink
	挂墙洗手星盆
Model Type (模具型号):	SHSC1-W C02

No:	Parts(零部件):	Material Specification(用料标准):
✓ 01	COUNTER TOP 柜台面	16GA. THK. SUS 304 S/S
02	LEG 支腿	∅38mm 16 GA. THK. SUS 304 S/S TUBE
03	ADJUSTABLE FOOT INSERT 可调节嵌入式底脚	LUI CHUEN KEE (CHN)
✓ 04	REINFORCEMENT 加固件	16 GA. THK. SUS 304 S/S
✓ 05	SINK BOWL 洗碗槽	16 GA. THK. SUS 304 S/S
06	SINK WASTE 废料槽	
07	S.S. CROSS RAIL 横梁	∅32mm 16 GA. THK. SUS 304 S/S TUBE
✓ 08	WALL MOUNTED BRACKET 壁装托架	16 GA. THK. SUS 304 S/S
09	UNDER SHELF 底架	18 GA. THK. SUS 304 S/S
✓ 10	MIXING FAUCET 混合龙头	
11	OVER SHELF 顶架	18 GA. THK. SUS 304 S/S
12	OUTER DOOR PANEL 外板	20 GA. THK. SUS 304 S/S
13	INNER DOOR PANEL 内板	22 GA. THK. SUS 304 S/S
14	CABINET BODY 柜身	20 GA. THK. SUS 304 S/S
15	CORNER BUMPER 拐角防护套	COLSON (CHN)
16	SWIVEL CASTOR 旋转角轮	GLOBE (CHN)
17	SOUND DEADEN MATERIAL 隔音材料	3mm THICKNESS
18	WALL FLASHING 防水面	20 GA. THK. SUS 304 S/S
19	CONDENSING UNIT 制冷机组	DANFOSS (CHN)
20	NOZZLE 排气口	∅25mm SUS 304 S/S TUBE

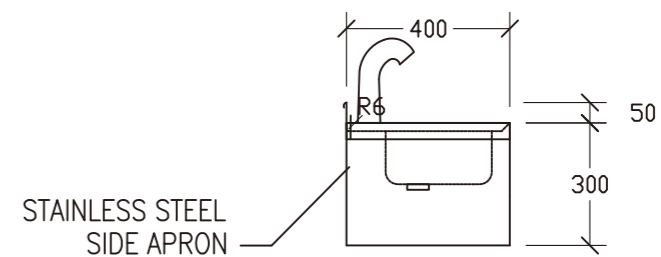
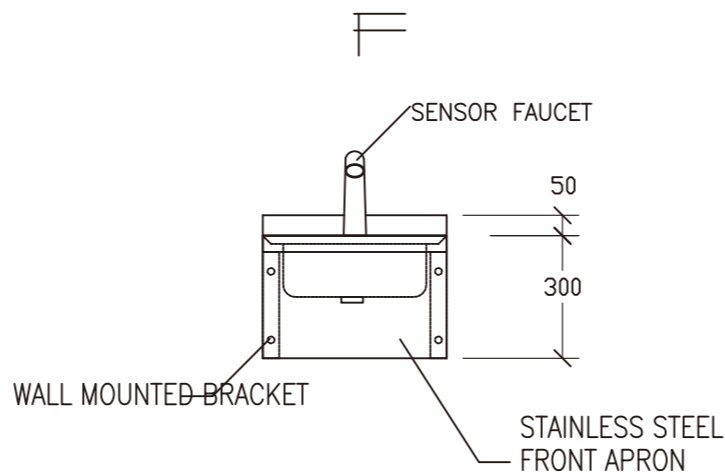

ELEVATION

SECTION

No:	Item No(款号):	Qty(数量):	No:	Item No(款号):	Qty(数量):

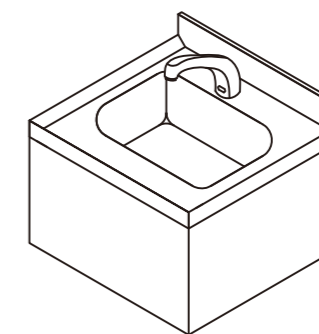
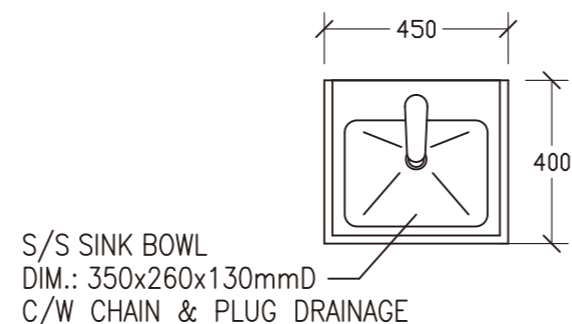

Remark(备注):



SPOT WELDED A THREADED SHAFT TO THE UNDERSIDE OF WORK TOP / SHELF. THEN USE UNITS TO FIX WITH THE REINFORCEMENT / BRACKETS

				技术说明:	SKU:					
				1.所有产品边缘不能有毛刺, 覆膜面不能刮花;	名称:	建德C40+潜水俱乐部厨房				
				2.公差要求标准: 符合GB/T G3280-2015不锈钢冷轧钢板和钢带标准中PT.A的公称宽度要求;	材料:					
				3.所有标注尺寸为外尺寸;	编制:					
				4.未注膜面方向朝外。	审核:					
A						日期:		视角:	☉ ☒	
版本			批准	日期		日期:		版本:	A	

STAINLESS STEEL SHOP DRAWING (CUSTOM)

不锈钢件生产要求图

Product Description (产品说明):	Work Table
	残菜回收台
Model Type (模具型号):	TB C03

No:	Parts(零部件):	Material Specification(用料标准):
✓ 01	COUNTER TOP 柜台面	16GA. THK. SUS 304 S/S
✓ 02	LEG 支腿	∅38mm 16 GA. THK. SUS 304 S/S TUBE
✓ 03	ADJUSTABLE FOOT INSERT 可调节嵌入式底脚	LUI CHUEN KEE (CHN)
✓ 04	REINFORCEMENT 加固件	16 GA. THK. SUS 304 S/S
05	SINK BOWL 洗碗槽	16 GA. THK. SUS 304 S/S
06	SINK WASTE 废料槽	
✓ 07	S.S. CROSS RAIL 横梁	∅32mm 16 GA. THK. SUS 304 S/S TUBE
08	WALL MOUNTED BRACKET 壁装托架	16 GA. THK. SUS 304 S/S
09	UNDER SHELF 底架	18 GA. THK. SUS 304 S/S
10	MIXING FAUCET 混合龙头	
11	OVER SHELF 顶架	18 GA. THK. SUS 304 S/S
12	OUTER DOOR PANEL 外板	20 GA. THK. SUS 304 S/S
13	INNER DOOR PANEL 内板	22 GA. THK. SUS 304 S/S
14	CABINET BODY 柜身	20 GA. THK. SUS 304 S/S
15	CORNER BUMPER 拐角防护套	COLSON (CHN)
16	SWIVEL CASTOR 旋转角轮	GLOBE (CHN)
17	SOUND DEADEN MATERIAL 隔音材料	3mm THICKNESS
18	WALL FLASHING 防水面	20 GA. THK. SUS 304 S/S
19	CONDENSING UNIT 制冷机组	DANFOSS (CHN)
20	NOZZLE 排气口	∅25mm SUS 304 S/S TUBE

No:	Item No(款号):	Qty(数量):	No:	Item No(款号):	Qty(数量):

Remark(备注):



SPOT WELDED A THREADED SHAFT TO THE UNDERSIDE OF WORK TOP / SHELF. THEN USE UNITS TO FIX WITH THE REINFORCEMENT / BRACKETS

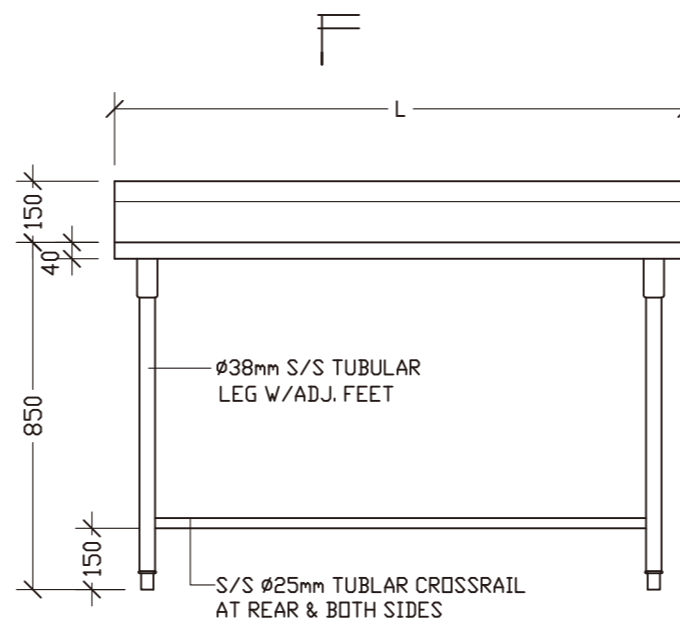

ELEVATION

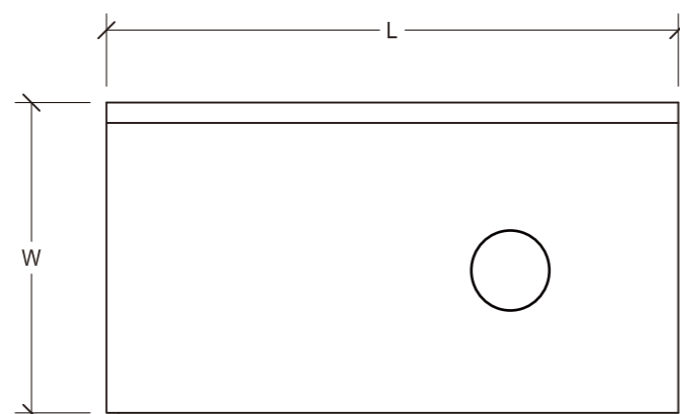

PLAN

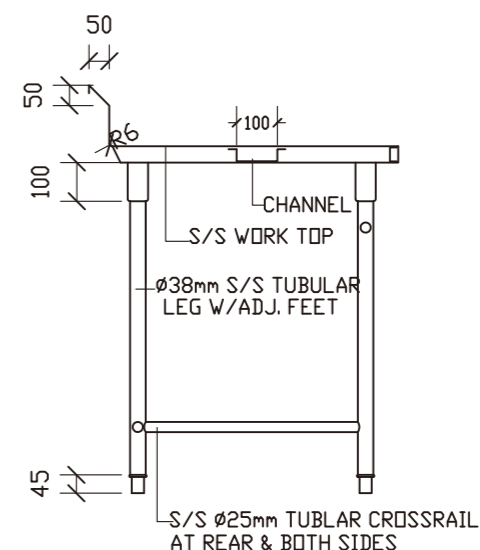

SECTION

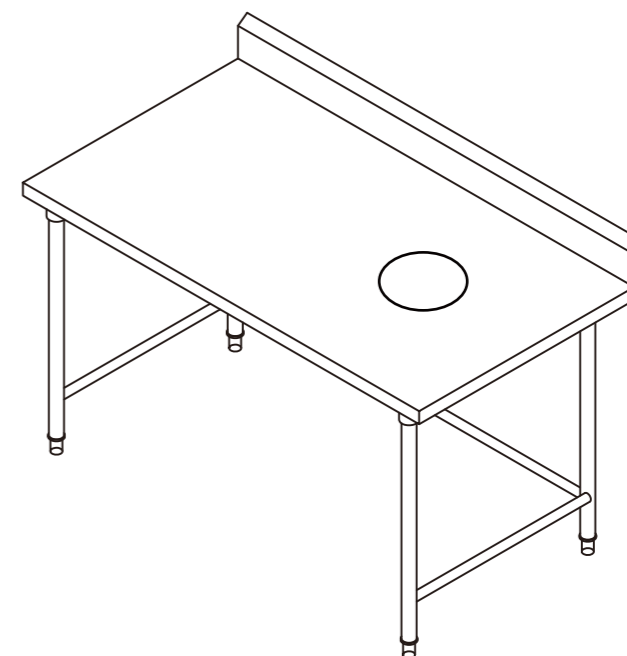

ISOMETRIC VIEW

技术说明:				SKU:			
1.所有产品边缘不能有毛刺, 覆膜面不能刮花;				名称:	建德C40+潜水俱乐部厨房		
2.公差要求标准: 符合GB/T G3280-2015不锈钢冷轧钢板和钢带标准中PT.A的公称宽度要求;				材料:			
3.所有标注尺寸为外尺寸;				编制:		日期:	
4.未注膜面方向朝外。				审核:		日期:	
A						视角:	☉ ☒
版本		批准	日期			版本:	A

STAINLESS STEEL SHOP DRAWING (CUSTOM)

不锈钢件生产要求图

Product Description (产品说明):	Combination Mop Sink Unit
	组合式拖地星盆
Model Type (模具型号):	PYT1 C04

No:	Parts(零部件):	Material Specfication(用料标准):
✓ 01	COUNTER TOP 柜台面	16GA. THK. SUS 304 S/S
✓ 02	LEG 支腿	∅38mm 16 GA. THK. SUS 304 S/S TUBE
✓ 03	ADJUSTABLE FOOT INSERT 可调节嵌入式底脚	LUI CHUEN KEE (CHN)
✓ 04	REINFORCEMENT 加固件	16 GA. THK. SUS 304 S/S
✓ 05	SINK BOWL 洗碗槽	16 GA. THK. SUS 304 S/S
06	SINK WASTE 废料槽	
✓ 07	S.S. CROSS RAIL 横梁	∅32mm 16 GA. THK. SUS 304 S/S TUBE
08	WALL MOUNTED BRACKET 壁装托架	16 GA. THK. SUS 304 S/S
09	UNDER SHELF 底架	18 GA. THK. SUS 304 S/S
✓ 10	MIXING FAUCET 混合龙头	
11	OVER SHELF 顶架	18 GA. THK. SUS 304 S/S
12	OUTER DOOR PANEL 外板	20 GA. THK. SUS 304 S/S
13	INNER DOOR PANEL 内板	22 GA. THK. SUS 304 S/S
14	CABINET BODY 柜身	20 GA. THK. SUS 304 S/S
15	CORNER BUMPER 拐角防护套	COLSON (CHN)
16	SWIVEL CASTOR 旋转角轮	GLOBE (CHN)
17	SOUND DEADEN MATERIAL 隔音材料	3mm THICKNESS
18	WALL FLASHING 防水面	20 GA. THK. SUS 304 S/S
19	CONDENSING UNIT 制冷机组	DANFOSS (CHN)
20	NOZZLE 排气口	∅25mm SUS 304 S/S TUBE

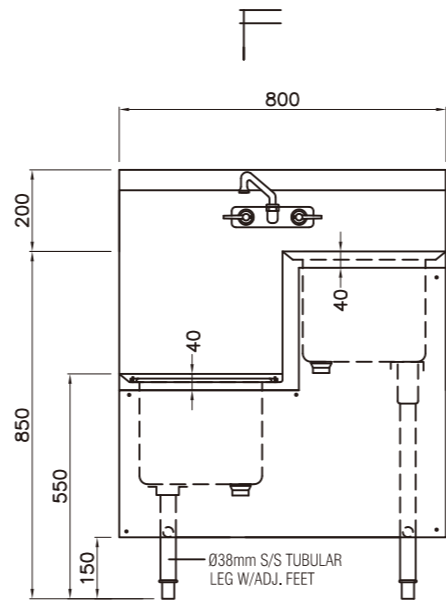

ELEVATION

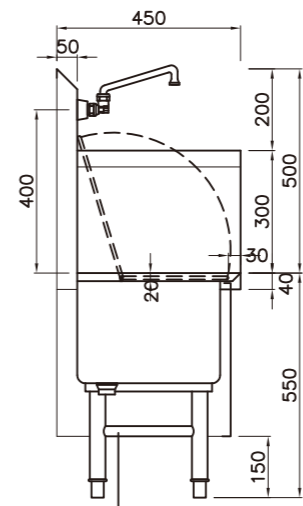

SECTION A

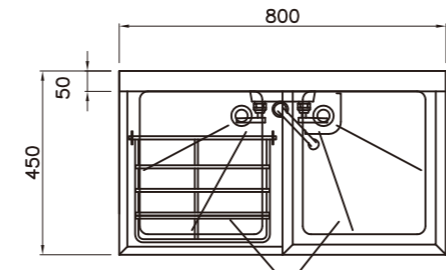

PLAN

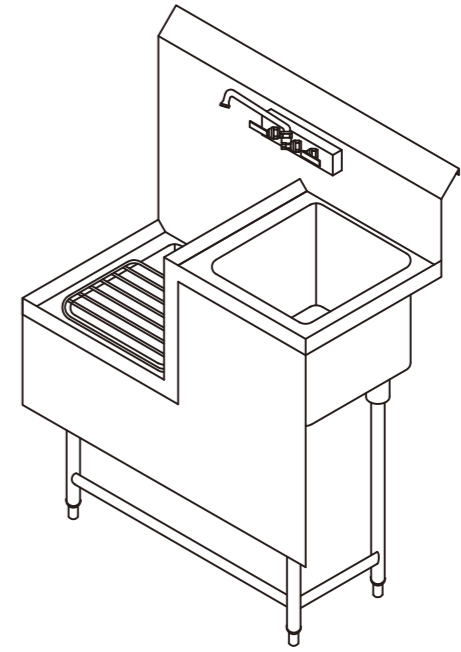

No:	Item No(款号):	Qty(数量):	No:	Item No(款号):	Qty(数量):

Remark(备注):

 M5

SPOT WELDED A THREADED SHAFT TO THE UNDERSIDE OF WORK TOP / SHELF. THEN USE UNITS TO FIX WITH THE REINFORCEMENT / BRACKETS

技术说明:				SKU:			
1.所有产品边缘不能有毛刺, 覆膜面不能刮花;				名称:	建德C40+潜水俱乐部厨房		
2.公差要求标准: 符合GB/T G3280-2015不锈钢冷轧钢板和钢带标准中PT.A的公称宽度要求;				材料:			
3.所有标注尺寸为外尺寸;				编制:		日期:	
4.未注膜面方向朝外。				审核:		日期:	
A						视角:	
版本		批准	日期			版本:	A

STAINLESS STEEL SHOP DRAWING (CUSTOM)

不锈钢件生产要求图

Product Description (产品说明):	4-Tier Square Tube Storage Shelving
	四层平板货架
Model Type (模具型号):	JFG4 D02

No:	Parts(零部件):	Material Specification(用料标准):
01	COUNTER TOP 柜台面	16GA. THK. SUS 304 S/S
✓ 02	LEG 支腿	∅38mm 16 GA. THK. SUS 304 S/S TUBE
✓ 03	ADJUSTABLE FOOT INSERT 可调节嵌入式底脚	LUI CHUEN KEE (CHN)
04	REINFORCEMENT 加固件	16 GA. THK. SUS 304 S/S
05	SINK BOWL 洗碗槽	16 GA. THK. SUS 304 S/S
06	SINK WASTE 废料槽	
✓ 07	S.S. CROSS RAIL 横梁	∅32mm 16 GA. THK. SUS 304 S/S TUBE
08	WALL MOUNTED BRACKET 壁装托架	16 GA. THK. SUS 304 S/S
09	UNDER SHELF 底架	18 GA. THK. SUS 304 S/S
10	MIXING FAUCET 混合龙头	
11	OVER SHELF 顶架	18 GA. THK. SUS 304 S/S
12	OUTER DOOR PANEL 外板	20 GA. THK. SUS 304 S/S
13	INNER DOOR PANEL 内板	22 GA. THK. SUS 304 S/S
14	CABINET BODY 柜身	20 GA. THK. SUS 304 S/S
15	CORNER BUMPER 拐角防护套	COLSON (CHN)
16	SWIVEL CASTOR 旋转角轮	GLOBE (CHN)
17	SOUND DEADEN MATERIAL 隔音材料	3mm THICKNESS
18	WALL FLASHING 防水面	20 GA. THK. SUS 304 S/S
19	CONDENSING UNIT 制冷机组	DANFOSS (CHN)
20	NOZZLE 排气口	∅25mm SUS 304 S/S TUBE

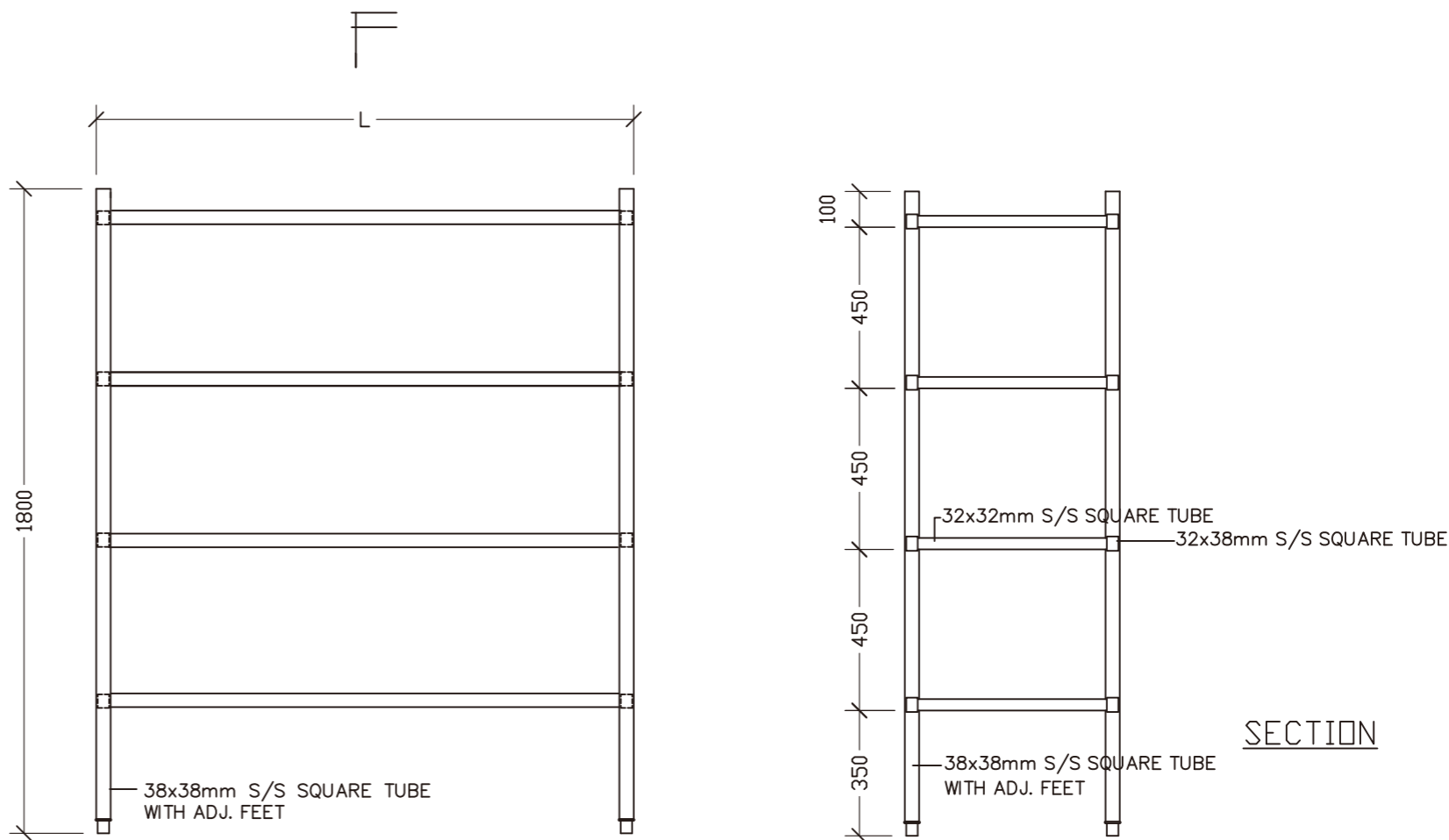

No:	Item No(款号):	Qty(数量):	No:	Item No(款号):	Qty(数量):

Remark(备注):



M5

SPOT WELDED A THREADED SHAFT TO THE UNDERSIDE OF WORK TOP / SHELF. THEN USE UNITS TO FIX WITH THE REINFORCEMENT / BRACKETS

ELEVATION

PLAN

SECTION

技术说明:				SKU:			
1.所有产品边缘不能有毛刺, 覆膜面不能刮花;				名称:	建德C40+潜水俱乐部厨房		
2.公差要求标准: 符合GB/T G3280-2015不锈钢冷轧钢板和钢带标准中PT.A的公称宽度要求;				材料:			
3.所有标注尺寸为外尺寸;				编制:		日期:	
4.未注膜面方向朝外。				审核:		日期:	
A						视角:	☉
版本		批准	日期			版本:	A

STAINLESS STEEL SHOP DRAWING (CUSTOM)

不锈钢件生产要求图

Product Description (产品说明):	Work Table
	单层工作台
Model Type (模具型号):	TB D03

No:	Parts(零部件):	Material Specification(用料标准):
✓ 01	COUNTER TOP 柜台面	16GA. THK. SUS 304 S/S
✓ 02	LEG 支腿	∅38mm 16 GA. THK. SUS 304 S/S TUBE
✓ 03	ADJUSTABLE FOOT INSERT 可调节嵌入式底脚	LUI CHUEN KEE (CHN)
✓ 04	REINFORCEMENT 加固件	16 GA. THK. SUS 304 S/S
05	SINK BOWL 洗碗槽	16 GA. THK. SUS 304 S/S
06	SINK WASTE 废料槽	
✓ 07	S.S. CROSS RAIL 横梁	∅32mm 16 GA. THK. SUS 304 S/S TUBE
08	WALL MOUNTED BRACKET 壁装托架	16 GA. THK. SUS 304 S/S
09	UNDER SHELF 底架	18 GA. THK. SUS 304 S/S
10	MIXING FAUCET 混合龙头	
11	OVER SHELF 顶架	18 GA. THK. SUS 304 S/S
12	OUTER DOOR PANEL 外板	20 GA. THK. SUS 304 S/S
13	INNER DOOR PANEL 内板	22 GA. THK. SUS 304 S/S
14	CABINET BODY 柜身	20 GA. THK. SUS 304 S/S
15	CORNER BUMPER 拐角防护套	COLSON (CHN)
16	SWIVEL CASTOR 旋转角轮	GLOBE (CHN)
17	SOUND DEADEN MATERIAL 隔音材料	3mm THICKNESS
18	WALL FLASHING 防水面	20 GA. THK. SUS 304 S/S
19	CONDENSING UNIT 制冷机组	DANFOSS (CHN)
20	NOZZLE 排气口	∅25mm SUS 304 S/S TUBE

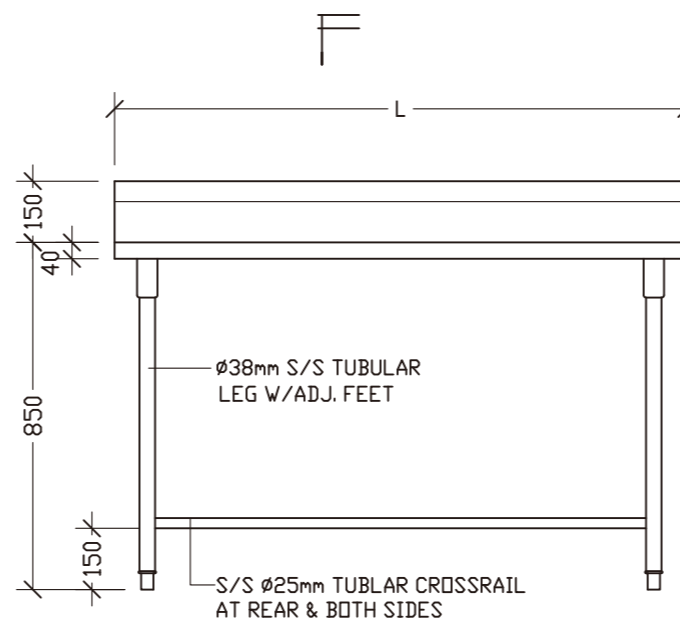

ELEVATION

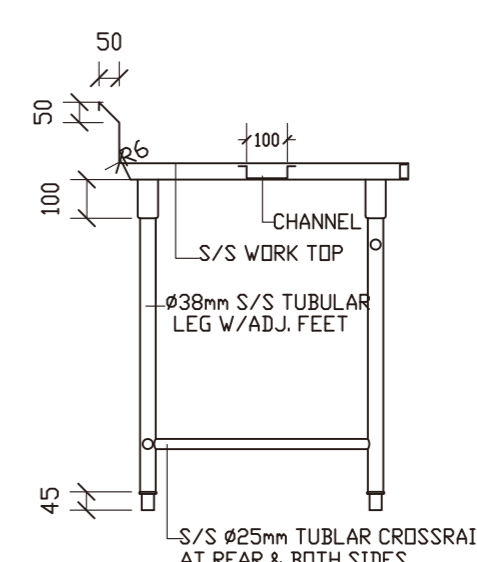

SECTION

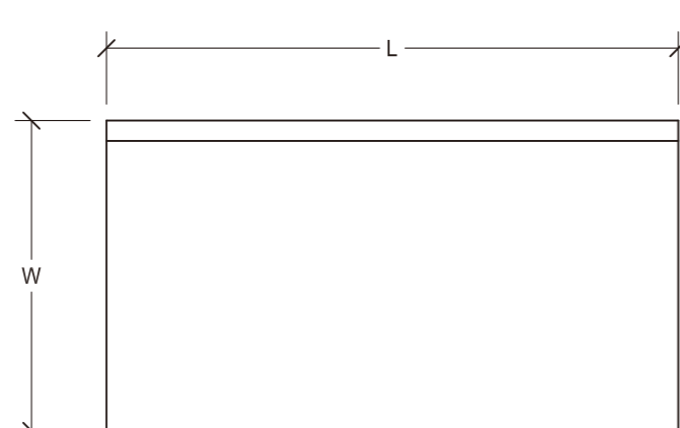

PLAN

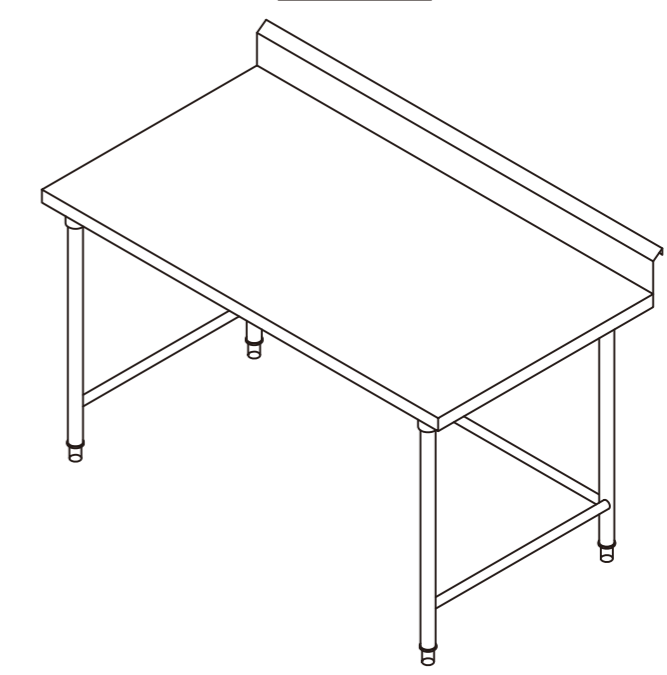

ISOMETRIC VIEW

No:	Item No(款号):	Qty(数量):	No:	Item No(款号):	Qty(数量):

Remark(备注):

 M5

SPOT WELDED A THREADED SHAFT TO THE UNDERSIDE OF WORK TOP / SHELF. THEN USE UNITS TO FIX WITH THE REINFORCEMENT / BRACKETS

技术说明:				SKU:			
1.所有产品边缘不能有毛刺, 覆膜面不能刮花;				名称:	建德C40+潜水俱乐部厨房		
2.公差要求标准: 符合GB/T G3280-2015不锈钢冷轧钢板和钢带标准中PT.A的公称宽度要求;				材料:			
3.所有标注尺寸为外尺寸;				编制:		日期:	
4.未注膜面方向朝外。				审核:		日期:	
A						视角:	
版本		批准	日期			版本:	A

STAINLESS STEEL SHOP DRAWING (CUSTOM)

不锈钢件生产要求图

Product Description (产品说明):	Fish Preparation Table W/Cut Board
	单星理鱼台带尼龙砧板
Model Type (模具型号):	SFSH1 D04

No:	Parts(零部件):	Material Specfication(用料标准):
✓ 01	COUNTER TOP 柜台面	16GA. THK. SUS 304 S/S
✓ 02	LEG 支腿	∅38mm 16 GA. THK. SUS 304 S/S TUBE
✓ 03	ADJUSTABLE FOOT INSERT 可调节嵌入式底脚	LUI CHUEN KEE (CHN)
✓ 04	REINFORCEMENT 加固件	16 GA. THK. SUS 304 S/S
✓ 05	SINK BOWL 洗碗槽	16 GA. THK. SUS 304 S/S
06	SINK WASTE 废料槽	
✓ 07	S.S. CROSS RAIL 横梁	∅32mm 16 GA. THK. SUS 304 S/S TUBE
08	WALL MOUNTED BRACKET 壁装托架	16 GA. THK. SUS 304 S/S
09	UNDER SHELF 底架	18 GA. THK. SUS 304 S/S
✓ 10	MIXING FAUCET 混合龙头	
11	OVER SHELF 顶架	18 GA. THK. SUS 304 S/S
12	OUTER DOOR PANEL 外板	20 GA. THK. SUS 304 S/S
13	INNER DOOR PANEL 内板	22 GA. THK. SUS 304 S/S
14	CABINET BODY 柜身	20 GA. THK. SUS 304 S/S
15	CORNER BUMPER 拐角防护套	COLSON (CHN)
16	SWIVEL CASTOR 旋转角轮	GLOBE (CHN)
17	SOUND DEADEN MATERIAL 隔音材料	3mm THICKNESS
18	WALL FLASHING 防水面	20 GA. THK. SUS 304 S/S
19	CONDENSING UNIT 制冷机组	DANFOSS (CHN)
20	NOZZLE 排气口	∅25mm SUS 304 S/S TUBE

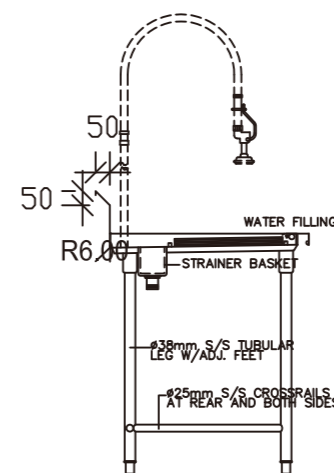
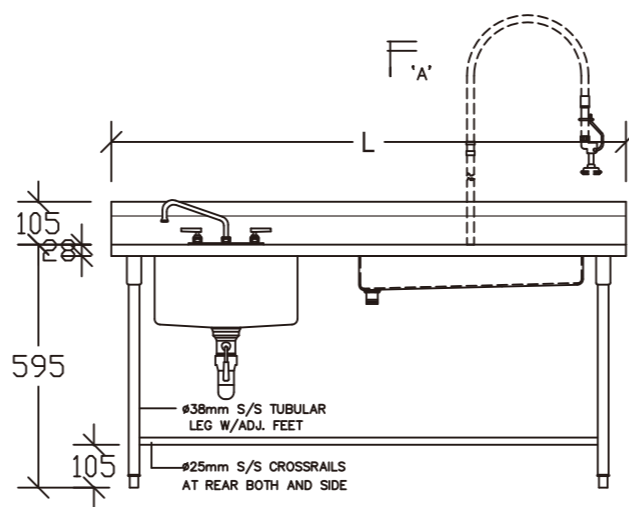

ELEVATION

SECTION

No:	Item No(款号):	Qty(数量):	No:	Item No(款号):	Qty(数量):

Remark(备注):

 M5

SPOT WELDED A THREADED SHAFT TO THE UNDERSIDE OF WORK TOP / SHELF. THEN USE UNITS TO FIX WITH THE REINFORCEMENT / BRACKETS

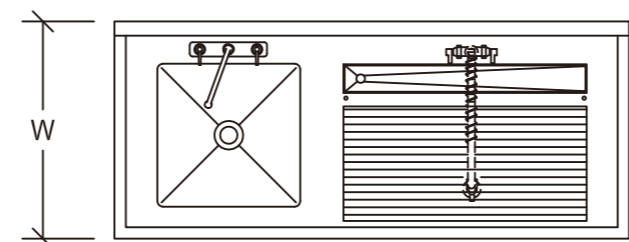

PLAN

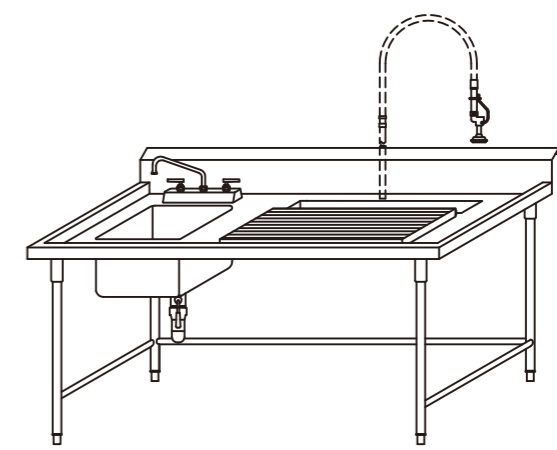

ISOMETRIC VIEW

技术说明:				SKU:			
1.所有产品边缘不能有毛刺, 覆膜面不能刮花;				名称:	建德C40+潜水俱乐部厨房		
2.公差要求标准: 符合GB/T G3280-2015不锈钢冷轧钢板和钢带标准中PT.A的公称宽度要求;				材料:			
3.所有标注尺寸为外尺寸;				编制:		日期:	
4.未注膜面方向朝外。				审核:		日期:	
A						视角:	
版本		批准	日期			版本:	A

STAINLESS STEEL SHOP DRAWING (CUSTOM)

不锈钢件生产要求图

Product Description (产品说明):	Work Table
	残菜回收台
Model Type (模具型号):	TB D05

No:	Parts(零部件):	Material Specification(用料标准):
✓ 01	COUNTER TOP 柜台面	16GA. THK. SUS 304 S/S
✓ 02	LEG 支腿	∅38mm 16 GA. THK. SUS 304 S/S TUBE
✓ 03	ADJUSTABLE FOOT INSERT 可调节嵌入式底脚	LUI CHUEN KEE (CHN)
✓ 04	REINFORCEMENT 加固件	16 GA. THK. SUS 304 S/S
05	SINK BOWL 洗碗槽	16 GA. THK. SUS 304 S/S
06	SINK WASTE 废料槽	
✓ 07	S.S. CROSS RAIL 横梁	∅32mm 16 GA. THK. SUS 304 S/S TUBE
08	WALL MOUNTED BRACKET 壁装托架	16 GA. THK. SUS 304 S/S
09	UNDER SHELF 底架	18 GA. THK. SUS 304 S/S
10	MIXING FAUCET 混合龙头	
11	OVER SHELF 顶架	18 GA. THK. SUS 304 S/S
12	OUTER DOOR PANEL 外板	20 GA. THK. SUS 304 S/S
13	INNER DOOR PANEL 内板	22 GA. THK. SUS 304 S/S
14	CABINET BODY 柜身	20 GA. THK. SUS 304 S/S
15	CORNER BUMPER 拐角防护套	COLSON (CHN)
16	SWIVEL CASTOR 旋转角轮	GLOBE (CHN)
17	SOUND DEADEN MATERIAL 隔音材料	3mm THICKNESS
18	WALL FLASHING 防水面	20 GA. THK. SUS 304 S/S
19	CONDENSING UNIT 制冷机组	DANFOSS (CHN)
20	NOZZLE 排气口	∅25mm SUS 304 S/S TUBE

No:	Item No(款号):	Qty(数量):	No:	Item No(款号):	Qty(数量):

Remark(备注):

 M5

SPOT WELDED A THREADED SHAFT TO THE UNDERSIDE OF WORK TOP / SHELF. THEN USE UNITS TO FIX WITH THE REINFORCEMENT / BRACKETS

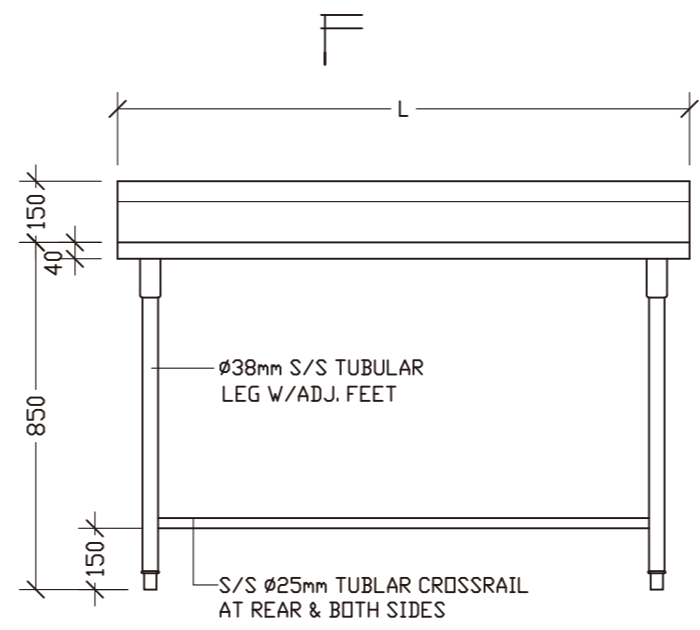

ELEVATION

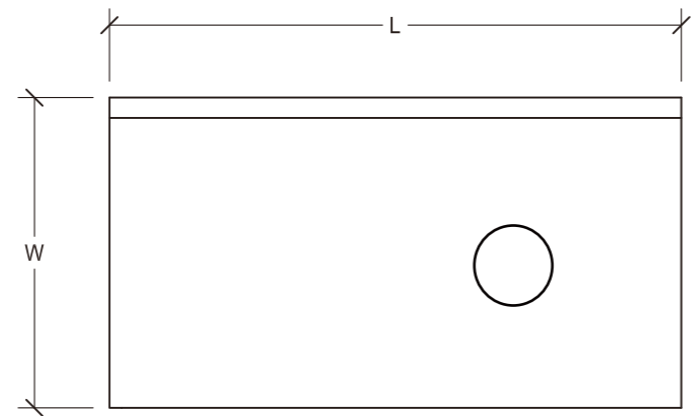

PLAN

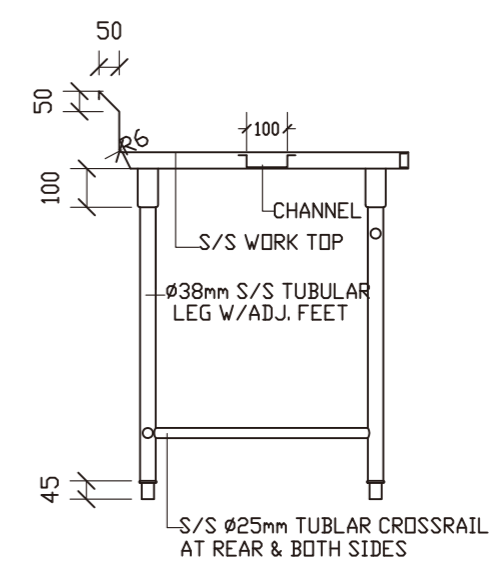

SECTION

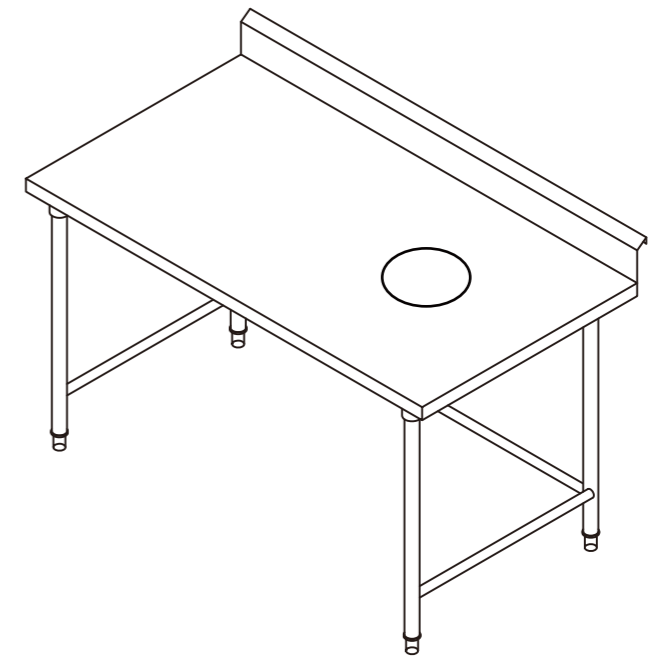

ISOMETRIC VIEW

技术说明:				SKU:			
1.所有产品边缘不能有毛刺, 覆膜面不能刮花;				名称:	建德C40+潜水俱乐部厨房		
2.公差要求标准: 符合GB/T G3280-2015不锈钢冷轧钢板和钢带标准中PT.A的公称宽度要求;				材料:			
3.所有标注尺寸为外尺寸;				编制:		日期:	
4.未注膜面方向朝外。				审核:		日期:	
A						视角:	
版本		批准	日期			版本:	A

STAINLESS STEEL SHOP DRAWING (CUSTOM)

不锈钢件生产要求图

Product Description (产品说明):	Chopping Table W/Nylon Cutting Board
	尼龙砧板工作台
Model Type (模具型号):	TBNCU D08

No:	Parts(零部件):	Material Specification(用料标准):
✓ 01	COUNTER TOP 柜台面	16GA. THK. SUS 304 S/S
✓ 02	LEG 支腿	∅38mm 16 GA. THK. SUS 304 S/S TUBE
✓ 03	ADJUSTABLE FOOT INSERT 可调节嵌入式底脚	LUI CHUEN KEE (CHN)
✓ 04	REINFORCEMENT 加固件	16 GA. THK. SUS 304 S/S
05	SINK BOWL 洗碗槽	16 GA. THK. SUS 304 S/S
06	SINK WASTE 废料槽	
✓ 07	S.S. CROSS RAIL 横梁	∅32mm 16 GA. THK. SUS 304 S/S TUBE
08	WALL MOUNTED BRACKET 壁装托架	16 GA. THK. SUS 304 S/S
09	UNDER SHELF 底架	18 GA. THK. SUS 304 S/S
10	MIXING FAUCET 混合龙头	
11	OVER SHELF 顶架	18 GA. THK. SUS 304 S/S
12	OUTER DOOR PANEL 外板	20 GA. THK. SUS 304 S/S
13	INNER DOOR PANEL 内板	22 GA. THK. SUS 304 S/S
14	CABINET BODY 柜身	20 GA. THK. SUS 304 S/S
15	CORNER BUMPER 拐角防护套	COLSON (CHN)
16	SWIVEL CASTOR 旋转角轮	GLOBE (CHN)
17	SOUND DEADEN MATERIAL 隔音材料	3mm THICKNESS
18	WALL FLASHING 防水面	20 GA. THK. SUS 304 S/S
19	CONDENSING UNIT 制冷机组	DANFOSS (CHN)
20	NOZZLE 排气口	∅25mm SUS 304 S/S TUBE

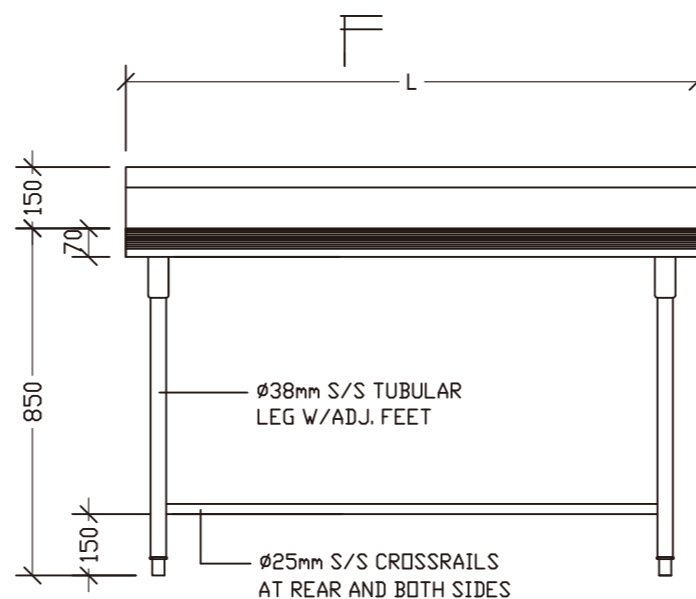

ELEVATION

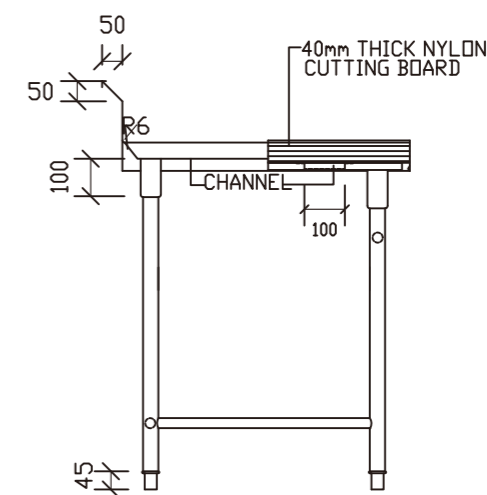

SECTION

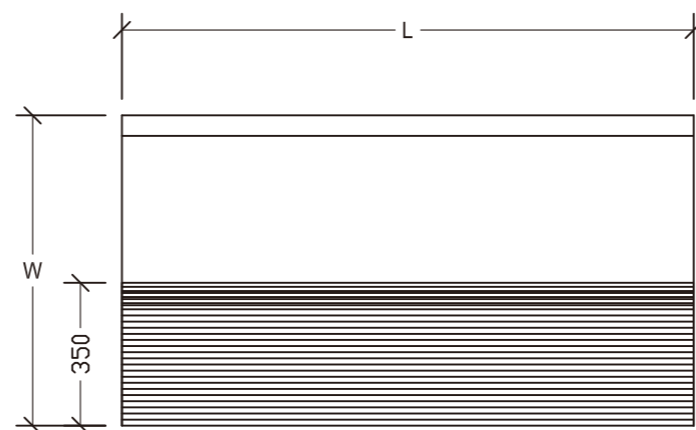

PLAN

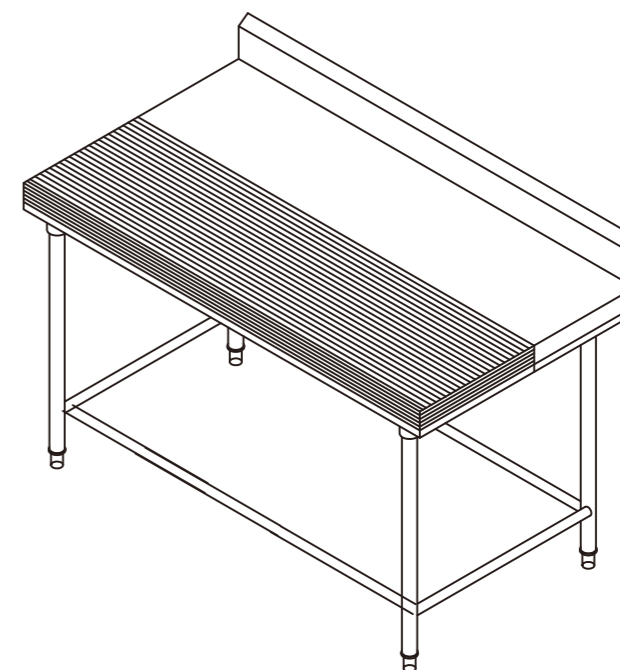

ISOMETRIC VIEW

No:	Item No(款号):	Qty(数量):	No:	Item No(款号):	Qty(数量):
	FUT-004				
	BUT-006				
	BUT-017				
	SEA-018				
	VEG-016				

Remark(备注):



SPOT WELDED A THREADED SHAFT TO THE UNDERSIDE OF WORK TOP / SHELF. THEN USE UNITS TO FIX WITH THE REINFORCEMENT / BRACKETS

				技术说明:	SKU:					
				1.所有产品边缘不能有毛刺, 覆膜面不能刮花;	名称:	建德C40+潜水俱乐部厨房				
				2.公差要求标准: 符合GB/T G3280-2015不锈钢冷轧钢板和钢带标准中PT.A的公称宽度要求;	材料:					
				3.所有标注尺寸为外尺寸;	编制:					
				4.未注膜面方向朝外。	审核:					
A					日期:			视角:	☉ ☒	
版本			批准	日期	日期:			版本:	A	

STAINLESS STEEL SHOP DRAWING (CUSTOM)

不锈钢件生产要求图

Product Description (产品说明):	Work Table W/Under Shelf
	工作台下置层板
Model Type (模具型号):	TBS1 D08a

No:	Parts(零部件):	Material Specfication(用料标准):
✓ 01	COUNTER TOP 柜台面	16GA. THK. SUS 304 S/S
✓ 02	LEG 支腿	∅38mm 16 GA. THK. SUS 304 S/S TUBE
✓ 03	ADJUSTABLE FOOT INSERT 可调节嵌入式底脚	LUI CHUEN KEE (CHN)
✓ 04	REINFORCEMENT 加固件	16 GA. THK. SUS 304 S/S
05	SINK BOWL 洗碗槽	16 GA. THK. SUS 304 S/S
06	SINK WASTE 废料槽	
✓ 07	S.S. CROSS RAIL 横梁	∅32mm 16 GA. THK. SUS 304 S/S TUBE
08	WALL MOUNTED BRACKET 壁装托架	16 GA. THK. SUS 304 S/S
09	UNDER SHELF 底架	18 GA. THK. SUS 304 S/S
10	MIXING FAUCET 混合龙头	
11	OVER SHELF 顶架	18 GA. THK. SUS 304 S/S
12	OUTER DOOR PANEL 外板	20 GA. THK. SUS 304 S/S
13	INNER DOOR PANEL 内板	22 GA. THK. SUS 304 S/S
14	CABINET BODY 柜身	20 GA. THK. SUS 304 S/S
15	CORNER BUMPER 拐角防护套	COLSON (CHN)
16	SWIVEL CASTOR 旋转角轮	GLOBE (CHN)
17	SOUND DEADEN MATERIAL 隔音材料	3mm THICKNESS
18	WALL FLASHING 防水面	20 GA. THK. SUS 304 S/S
19	CONDENSING UNIT 制冷机组	DANFOSS (CHN)
20	NOZZLE 排气口	∅25mm SUS 304 S/S TUBE

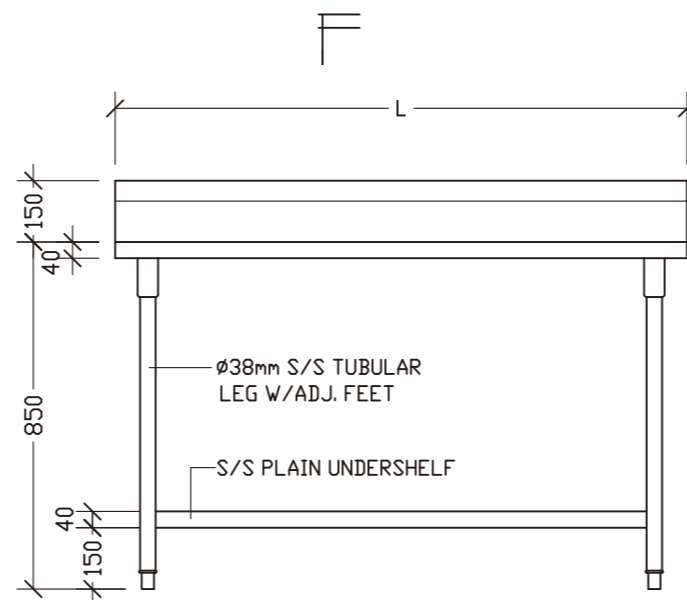

ELEVATION

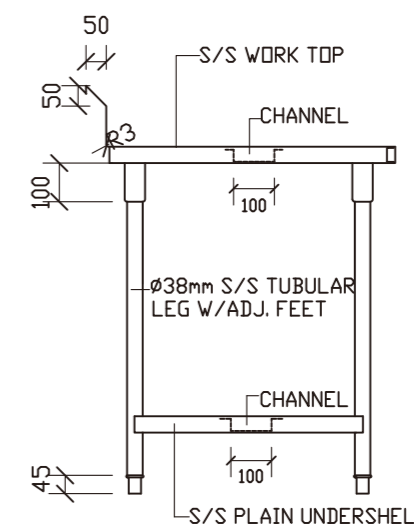

SECTION

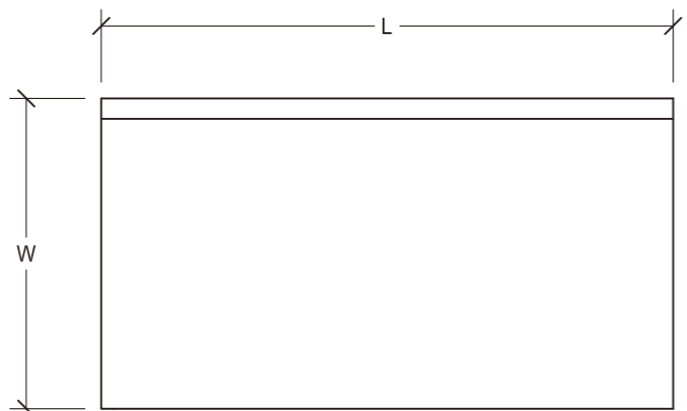

PLAN

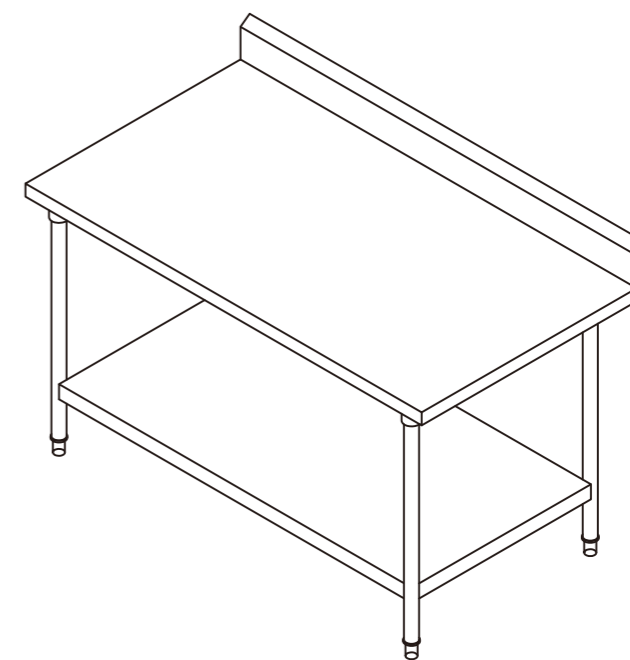

ISOMETRIC VIEW

No:	Item No(款号):	Qty(数量):	No:	Item No(款号):	Qty(数量):

Remark(备注):



M5

SPOT WELDED A THREADED SHAFT TO THE UNDERSIDE OF WORK TOP / SHELF. THEN USE UNITS TO FIX WITH THE REINFORCEMENT / BRACKETS

技术说明:
 1.所有产品边缘不能有毛刺, 覆膜面不能刮花;
 2.公差要求标准: 符合GB/T G3280-2015不锈钢冷轧钢板和钢带标准中PT.A的公称宽度要求;
 3.所有标注尺寸为外尺寸;
 4.未注膜面方向朝外。

SKU:
 名称: 建德C40+潜水俱乐部厨房
 材料:
 编制:
 审核:

日期:
 日期:
 视角:
 版本: A

STAINLESS STEEL SHOP DRAWING (CUSTOM)

不锈钢件生产要求图

Product Description (产品说明):	Work Table W/Twin Sinks
	工作台连双星盆 (中间去水)
Model Type (模具型号):	STSH2 D09

No:	Parts(零部件):	Material Specification(用料标准):
✓ 01	COUNTER TOP 柜台面	16GA. THK. SUS 304 S/S
✓ 02	LEG 支腿	∅38mm 16 GA. THK. SUS 304 S/S TUBE
✓ 03	ADJUSTABLE FOOT INSERT 可调节嵌入式底脚	LUI CHUEN KEE (CHN)
✓ 04	REINFORCEMENT 加固件	16 GA. THK. SUS 304 S/S
✓ 05	SINK BOWL 洗碗槽	16 GA. THK. SUS 304 S/S
06	SINK WASTE 废料槽	
✓ 07	S.S. CROSS RAIL 横梁	∅32mm 16 GA. THK. SUS 304 S/S TUBE
08	WALL MOUNTED BRACKET 壁装托架	16 GA. THK. SUS 304 S/S
09	UNDER SHELF 底架	18 GA. THK. SUS 304 S/S
✓ 10	MIXING FAUCET 混合龙头	
11	OVER SHELF 顶架	18 GA. THK. SUS 304 S/S
12	OUTER DOOR PANEL 外板	20 GA. THK. SUS 304 S/S
13	INNER DOOR PANEL 内板	22 GA. THK. SUS 304 S/S
14	CABINET BODY 柜身	20 GA. THK. SUS 304 S/S
15	CORNER BUMPER 拐角防护套	COLSON (CHN)
16	SWIVEL CASTOR 旋转角轮	GLOBE (CHN)
17	SOUND DEADEN MATERIAL 隔音材料	3mm THICKNESS
18	WALL FLASHING 防水面	20 GA. THK. SUS 304 S/S
19	CONDENSING UNIT 制冷机组	DANFOSS (CHN)
20	NOZZLE 排气口	∅25mm SUS 304 S/S TUBE

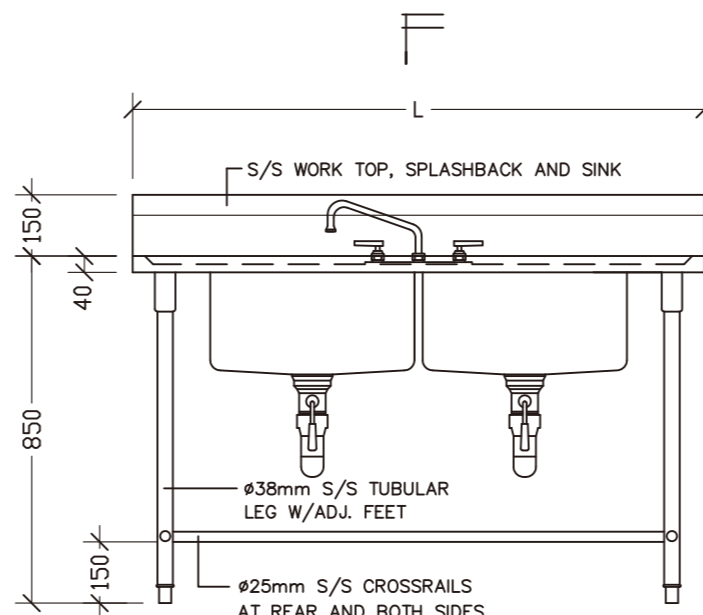

ELEVATION

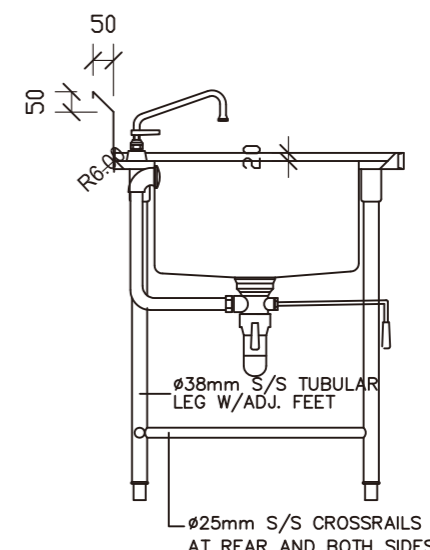

SECTION

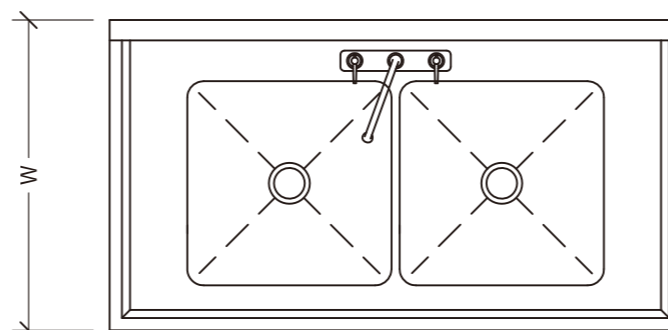

PLAN

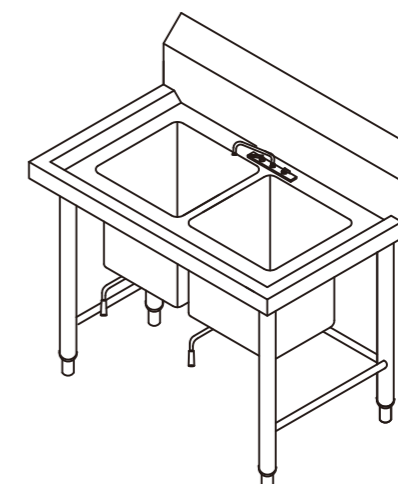

ISOMETRIC VIEW

No:	Item No(款号):	Qty(数量):	No:	Item No(款号):	Qty(数量):

Remark(备注):



SPOT WELDED A THREADED SHAFT TO THE UNDERSIDE OF WORK TOP / SHELF. THEN USE UNITS TO FIX WITH THE REINFORCEMENT / BRACKETS

技术说明:				SKU:			
1.所有产品边缘不能有毛刺, 覆膜面不能刮花;				名称:	建德C40+潜水俱乐部厨房		
2.公差要求标准: 符合GB/T G3280-2015不锈钢冷轧钢板和钢带标准中PT.A的公称宽度要求;				材料:			
3.所有标注尺寸为外尺寸;				编制:		日期:	
4.未注膜面方向朝外。				审核:		日期:	
A						视角:	☉
版本		批准	日期			版本:	A

STAINLESS STEEL SHOP DRAWING (CUSTOM)

不锈钢件生产要求图

Product Description (产品说明):	Work Table
	工作台
Model Type (模具型号):	TB D10

No:	Parts(零部件):	Material Specification(用料标准):
✓ 01	COUNTER TOP 柜台面	16GA. THK. SUS 304 S/S
✓ 02	LEG 支腿	∅38mm 16 GA. THK. SUS 304 S/S TUBE
✓ 03	ADJUSTABLE FOOT INSERT 可调节嵌入式底脚	LUI CHUEN KEE (CHN)
✓ 04	REINFORCEMENT 加固件	16 GA. THK. SUS 304 S/S
05	SINK BOWL 洗碗槽	16 GA. THK. SUS 304 S/S
06	SINK WASTE 废料槽	
✓ 07	S.S. CROSS RAIL 横梁	∅32mm 16 GA. THK. SUS 304 S/S TUBE
08	WALL MOUNTED BRACKET 壁装托架	16 GA. THK. SUS 304 S/S
09	UNDER SHELF 底架	18 GA. THK. SUS 304 S/S
10	MIXING FAUCET 混合龙头	
11	OVER SHELF 顶架	18 GA. THK. SUS 304 S/S
12	OUTER DOOR PANEL 外板	20 GA. THK. SUS 304 S/S
13	INNER DOOR PANEL 内板	22 GA. THK. SUS 304 S/S
14	CABINET BODY 柜身	20 GA. THK. SUS 304 S/S
15	CORNER BUMPER 拐角防护套	COLSON (CHN)
16	SWIVEL CASTOR 旋转角轮	GLOBE (CHN)
17	SOUND DEADEN MATERIAL 隔音材料	3mm THICKNESS
18	WALL FLASHING 防水面	20 GA. THK. SUS 304 S/S
19	CONDENSING UNIT 制冷机组	DANFOSS (CHN)
20	NOZZLE 排气口	∅25mm SUS 304 S/S TUBE

No:	Item No(款号):	Qty(数量):	No:	Item No(款号):	Qty(数量):

Remark(备注):

 M5

SPOT WELDED A THREADED SHAFT TO THE UNDERSIDE OF WORK TOP / SHELF. THEN USE UNITS TO FIX WITH THE REINFORCEMENT / BRACKETS

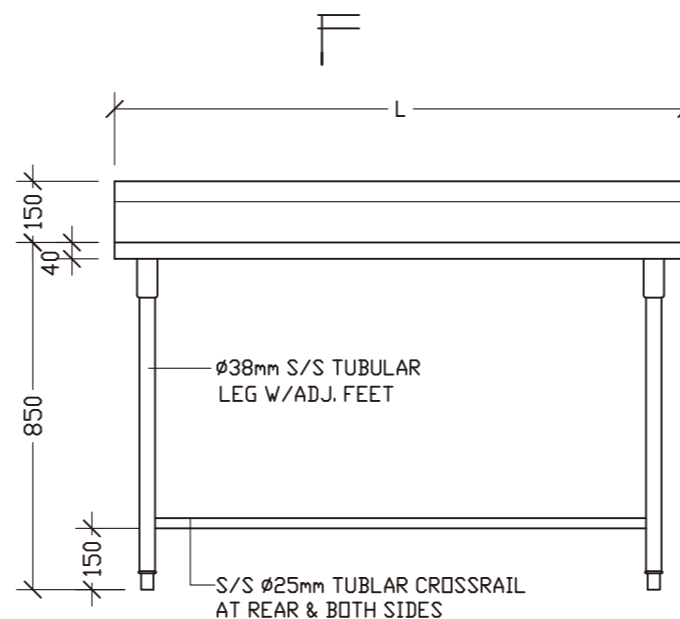

ELEVATION

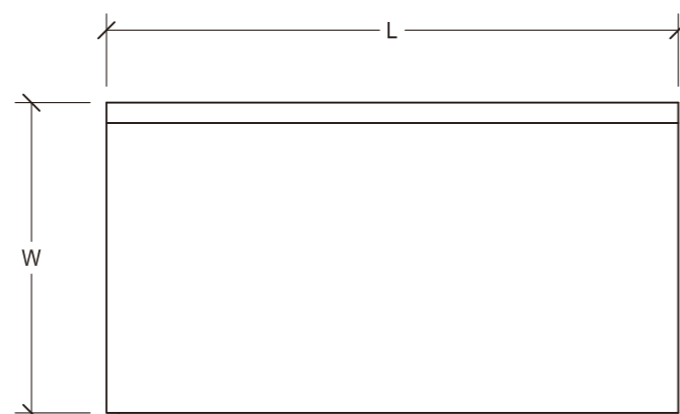

PLAN

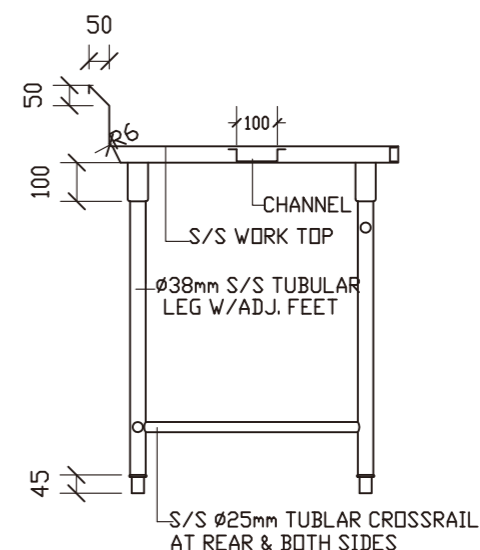

SECTION

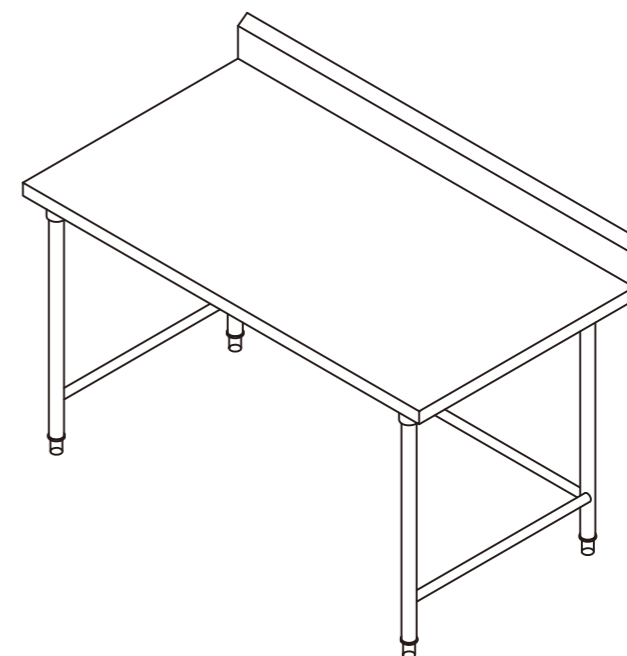

ISOMETRIC VIEW

技术说明:				SKU:			
1.所有产品边缘不能有毛刺, 覆膜面不能刮花;				名称:	建德C40+潜水俱乐部厨房		
2.公差要求标准: 符合GB/T G3280-2015不锈钢冷轧钢板和钢带标准中PT.A的公称宽度要求;				材料:			
3.所有标注尺寸为外尺寸;				编制:		日期:	
4.未注膜面方向朝外。				审核:		日期:	
A						视角:	
版本		批准	日期			版本:	A

STAINLESS STEEL SHOP DRAWING (CUSTOM)

不锈钢件生产要求图

Product Description (产品说明):	Single Wall Mounted Shelving
	单层挂墙层架
Model Type (模具型号):	JBW1 D13

No:	Parts(零部件):	Material Specification(用料标准):
01	COUNTER TOP 柜台面	16GA. THK. SUS 304 S/S
02	LEG 支腿	∅38mm 16 GA. THK. SUS 304 S/S TUBE
03	ADJUSTABLE FOOT INSERT 可调节嵌入式底脚	LUI CHUEN KEE (CHN)
✓ 04	REINFORCEMENT 加固件	16 GA. THK. SUS 304 S/S
05	SINK BOWL 洗碗槽	16 GA. THK. SUS 304 S/S
06	SINK WASTE 废料槽	
07	S.S. CROSS RAIL 横梁	∅32mm 16 GA. THK. SUS 304 S/S TUBE
✓ 08	WALL MOUNTED BRACKET 壁装托架	16 GA. THK. SUS 304 S/S
09	UNDER SHELF 底架	18 GA. THK. SUS 304 S/S
10	MIXING FAUCET 混合龙头	
✓ 11	OVER SHELF 顶架	18 GA. THK. SUS 304 S/S
12	OUTER DOOR PANEL 外板	20 GA. THK. SUS 304 S/S
13	INNER DOOR PANEL 内板	22 GA. THK. SUS 304 S/S
14	CABINET BODY 柜身	20 GA. THK. SUS 304 S/S
15	CORNER BUMPER 拐角防护套	COLSON (CHN)
16	SWIVEL CASTOR 旋转角轮	GLOBE (CHN)
17	SOUND DEADEN MATERIAL 隔音材料	3mm THICKNESS
18	WALL FLASHING 防水面	20 GA. THK. SUS 304 S/S
19	CONDENSING UNIT 制冷机组	DANFOSS (CHN)
20	NOZZLE 排气口	∅25mm SUS 304 S/S TUBE

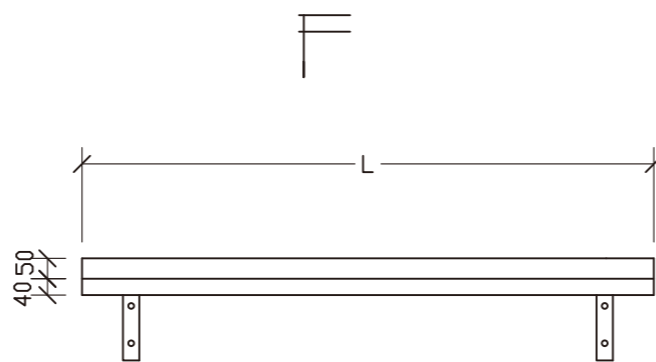

ELEVATION

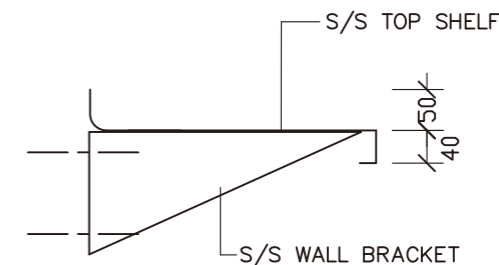

SECTION

No:	Item No(款号):	Qty(数量):	No:	Item No(款号):	Qty(数量):

Remark(备注):



SPOT WELDED A THREADED SHAFT TO THE UNDERSIDE OF WORK TOP / SHELF. THEN USE UNITS TO FIX WITH THE REINFORCEMENT / BRACKETS



PLAN

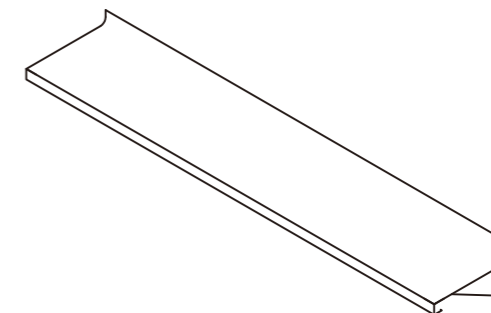

ISOMETRIC VIEW

技术说明:				SKU:			
1.所有产品边缘不能有毛刺, 覆膜面不能刮花;				名称:	建德C40+潜水俱乐部厨房		
2.公差要求标准: 符合GB/T G3280-2015不锈钢冷轧钢板和钢带标准中PT.A的公称宽度要求;				材料:			
3.所有标注尺寸为外尺寸;				编制:		日期:	
4.未注膜面方向朝外。				审核:		日期:	
A						视角:	☉
版本		批准	日期			版本:	A

STAINLESS STEEL SHOP DRAWING (CUSTOM)

不锈钢件生产要求图

Product Description (产品说明):	Single Wall Mounted Shelving
	单层挂墙层架
Model Type (模具型号):	JBW1 D14

No:	Parts(零部件):	Material Specification(用料标准):
01	COUNTER TOP 柜台面	16GA. THK. SUS 304 S/S
02	LEG 支腿	∅38mm 16 GA. THK. SUS 304 S/S TUBE
03	ADJUSTABLE FOOT INSERT 可调节嵌入式底脚	LUI CHUEN KEE (CHN)
✓ 04	REINFORCEMENT 加固件	16 GA. THK. SUS 304 S/S
05	SINK BOWL 洗碗槽	16 GA. THK. SUS 304 S/S
06	SINK WASTE 废料槽	
07	S.S. CROSS RAIL 横梁	∅32mm 16 GA. THK. SUS 304 S/S TUBE
✓ 08	WALL MOUNTED BRACKET 壁装托架	16 GA. THK. SUS 304 S/S
09	UNDER SHELF 底架	18 GA. THK. SUS 304 S/S
10	MIXING FAUCET 混合龙头	
✓ 11	OVER SHELF 顶架	18 GA. THK. SUS 304 S/S
12	OUTER DOOR PANEL 外板	20 GA. THK. SUS 304 S/S
13	INNER DOOR PANEL 内板	22 GA. THK. SUS 304 S/S
14	CABINET BODY 柜身	20 GA. THK. SUS 304 S/S
15	CORNER BUMPER 拐角防护套	COLSON (CHN)
16	SWIVEL CASTOR 旋转角轮	GLOBE (CHN)
17	SOUND DEADEN MATERIAL 隔音材料	3mm THICKNESS
18	WALL FLASHING 防水面	20 GA. THK. SUS 304 S/S
19	CONDENSING UNIT 制冷机组	DANFOSS (CHN)
20	NOZZLE 排气口	∅25mm SUS 304 S/S TUBE

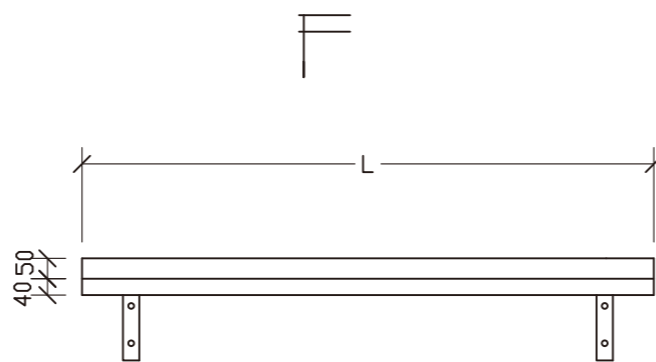

ELEVATION

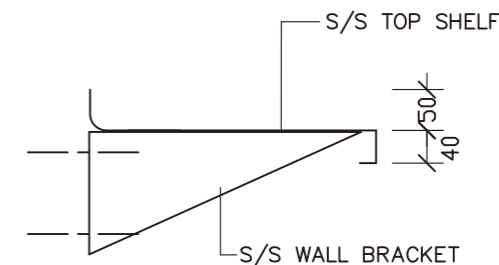

SECTION

No:	Item No(款号):	Qty(数量):	No:	Item No(款号):	Qty(数量):

Remark(备注):



SPOT WELDED A THREADED SHAFT TO THE UNDERSIDE OF WORK TOP / SHELF. THEN USE UNITS TO FIX WITH THE REINFORCEMENT / BRACKETS



PLAN

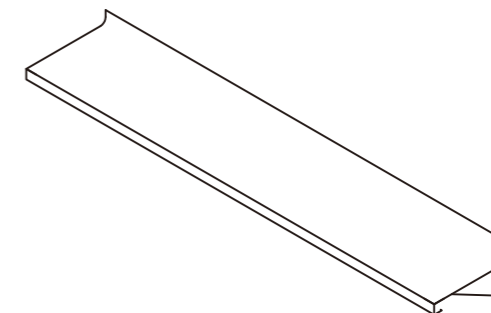

ISOMETRIC VIEW

技术说明:				SKU:			
1.所有产品边缘不能有毛刺, 覆膜面不能刮花;				名称:	建德C40+潜水俱乐部厨房		
2.公差要求标准: 符合GB/T G3280-2015不锈钢冷轧钢板和钢带标准中PT.A的公称宽度要求;				材料:			
3.所有标注尺寸为外尺寸;				编制:		日期:	
4.未注膜面方向朝外。				审核:		日期:	
A						视角:	☉
版本		批准	日期			版本:	A

STAINLESS STEEL SHOP DRAWING (CUSTOM)

不锈钢件生产要求图

Product Description (产品说明):	Single Wall Mounted Shelving
	单层挂墙层架
Model Type (模具型号):	JBW1 D15

No:	Parts(零部件):	Material Specification(用料标准):
01	COUNTER TOP 柜台面	16GA. THK. SUS 304 S/S
02	LEG 支腿	∅38mm 16 GA. THK. SUS 304 S/S TUBE
03	ADJUSTABLE FOOT INSERT 可调节嵌入式底脚	LUI CHUEN KEE (CHN)
✓ 04	REINFORCEMENT 加固件	16 GA. THK. SUS 304 S/S
05	SINK BOWL 洗碗槽	16 GA. THK. SUS 304 S/S
06	SINK WASTE 废料槽	
07	S.S. CROSS RAIL 横梁	∅32mm 16 GA. THK. SUS 304 S/S TUBE
✓ 08	WALL MOUNTED BRACKET 壁装托架	16 GA. THK. SUS 304 S/S
09	UNDER SHELF 底架	18 GA. THK. SUS 304 S/S
10	MIXING FAUCET 混合龙头	
✓ 11	OVER SHELF 顶架	18 GA. THK. SUS 304 S/S
12	OUTER DOOR PANEL 外板	20 GA. THK. SUS 304 S/S
13	INNER DOOR PANEL 内板	22 GA. THK. SUS 304 S/S
14	CABINET BODY 柜身	20 GA. THK. SUS 304 S/S
15	CORNER BUMPER 拐角防护套	COLSON (CHN)
16	SWIVEL CASTOR 旋转角轮	GLOBE (CHN)
17	SOUND DEADEN MATERIAL 隔音材料	3mm THICKNESS
18	WALL FLASHING 防水面	20 GA. THK. SUS 304 S/S
19	CONDENSING UNIT 制冷机组	DANFOSS (CHN)
20	NOZZLE 排气口	∅25mm SUS 304 S/S TUBE

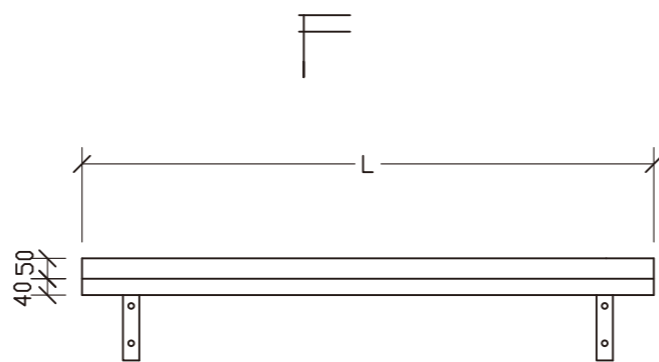

ELEVATION

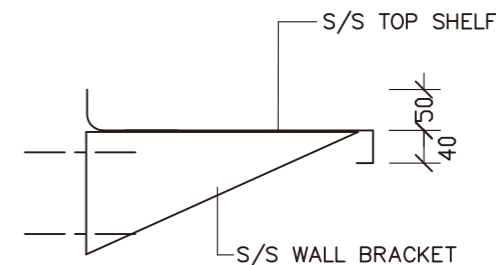

SECTION

No:	Item No(款号):	Qty(数量):	No:	Item No(款号):	Qty(数量):

Remark(备注):



SPOT WELDED A THREADED SHAFT TO THE UNDERSIDE OF WORK TOP / SHELF. THEN USE UNITS TO FIX WITH THE REINFORCEMENT / BRACKETS



PLAN

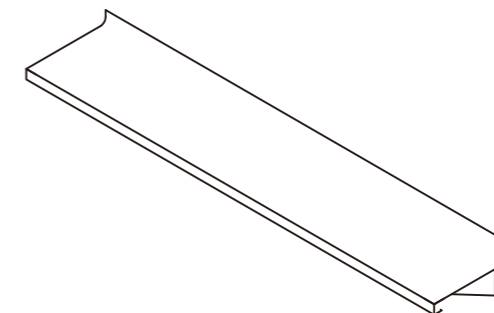

ISOMETRIC VIEW

技术说明:				SKU:			
1.所有产品边缘不能有毛刺, 覆膜面不能刮花;				名称:	建德C40+潜水俱乐部厨房		
2.公差要求标准: 符合GB/T G3280-2015不锈钢冷轧钢板和钢带标准中PT.A的公称宽度要求;				材料:			
3.所有标注尺寸为外尺寸;				编制:		日期:	
4.未注膜面方向朝外。				审核:		日期:	
A						视角:	☉
版本		批准	日期			版本:	A

STAINLESS STEEL SHOP DRAWING (CUSTOM)

不锈钢件生产要求图

Product Description (产品说明):	4-Tier Square Tube Storage Shelving
	四层通架
Model Type (模具型号):	JFG4 E03

No:	Parts(零部件):	Material Specification(用料标准):
01	COUNTER TOP 柜台面	16GA. THK. SUS 304 S/S
✓ 02	LEG 支腿	∅38mm 16 GA. THK. SUS 304 S/S TUBE
✓ 03	ADJUSTABLE FOOT INSERT 可调节嵌入式底脚	LUI CHUEN KEE (CHN)
04	REINFORCEMENT 加固件	16 GA. THK. SUS 304 S/S
05	SINK BOWL 洗碗槽	16 GA. THK. SUS 304 S/S
06	SINK WASTE 废料槽	
✓ 07	S.S. CROSS RAIL 横梁	∅32mm 16 GA. THK. SUS 304 S/S TUBE
08	WALL MOUNTED BRACKET 壁装托架	16 GA. THK. SUS 304 S/S
09	UNDER SHELF 底架	18 GA. THK. SUS 304 S/S
10	MIXING FAUCET 混合龙头	
11	OVER SHELF 顶架	18 GA. THK. SUS 304 S/S
12	OUTER DOOR PANEL 外板	20 GA. THK. SUS 304 S/S
13	INNER DOOR PANEL 内板	22 GA. THK. SUS 304 S/S
14	CABINET BODY 柜身	20 GA. THK. SUS 304 S/S
15	CORNER BUMPER 拐角防护套	COLSON (CHN)
16	SWIVEL CASTOR 旋转角轮	GLOBE (CHN)
17	SOUND DEADEN MATERIAL 隔音材料	3mm THICKNESS
18	WALL FLASHING 防水面	20 GA. THK. SUS 304 S/S
19	CONDENSING UNIT 制冷机组	DANFOSS (CHN)
20	NOZZLE 排气口	∅25mm SUS 304 S/S TUBE

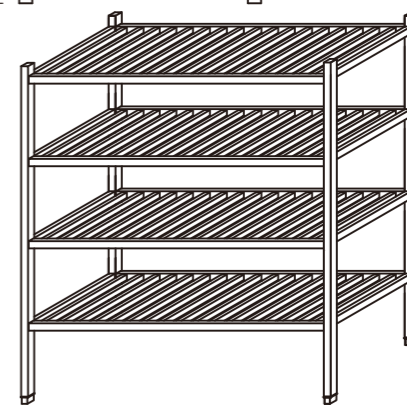
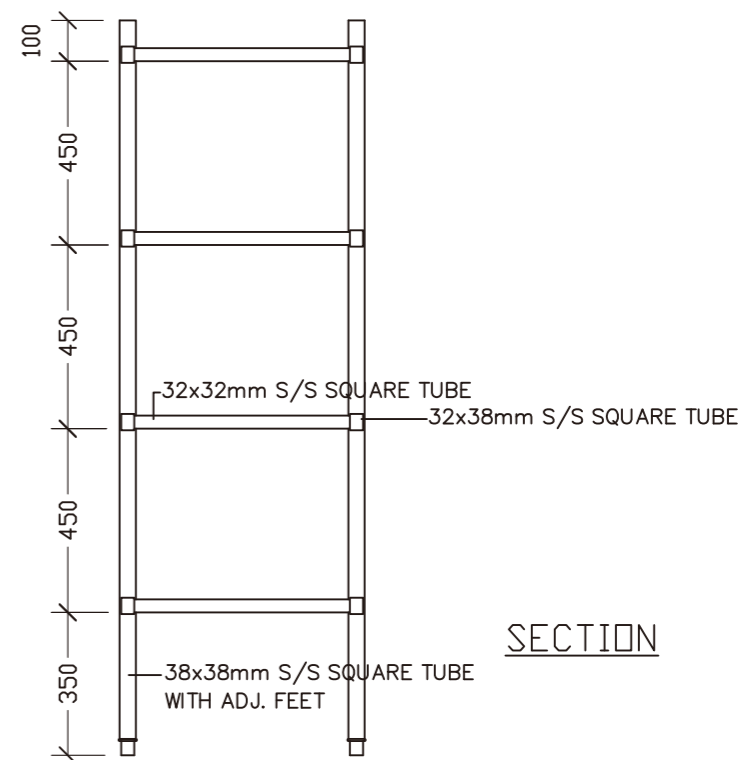
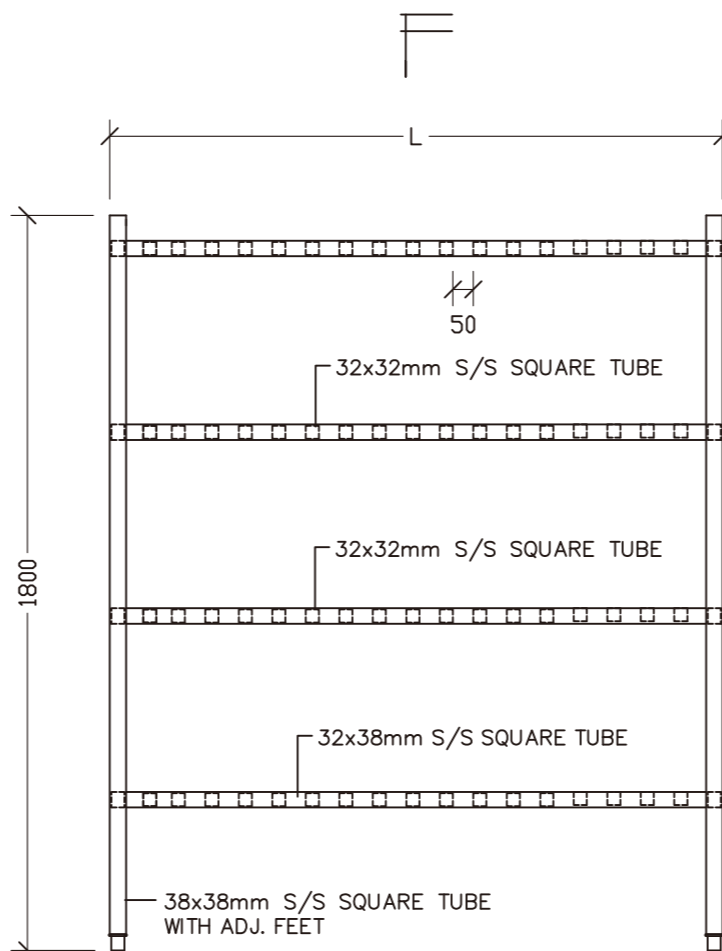

No:	Item No(款号):	Qty(数量):	No:	Item No(款号):	Qty(数量):

Remark(备注):



SPOT WELDED A THREADED SHAFT TO THE UNDERSIDE OF WORK TOP / SHELF. THEN USE UNITS TO FIX WITH THE REINFORCEMENT / BRACKETS

ELEVATION

PLAN

SECTION

ISOMETRIC VIEW

技术说明:				SKU:			
1.所有产品边缘不能有毛刺, 覆膜面不能刮花;				名称:	建德C40+潜水俱乐部厨房		
2.公差要求标准: 符合GB/T G3280-2015不锈钢冷轧钢板和钢带标准中PT.A的公称宽度要求;				材料:			
3.所有标注尺寸为外尺寸;				编制:		日期:	
4.未注膜面方向朝外。				审核:		日期:	
A						视角:	⊕
版本			批准	日期		版本:	A

STAINLESS STEEL SHOP DRAWING (CUSTOM)

不锈钢件生产要求图

Product Description (产品说明):	4-Tier Square Tube Storage Shelving
	四层通架
Model Type (模具型号):	JFG4 E04

No:	Parts(零部件):	Material Specification(用料标准):
01	COUNTER TOP 柜台面	16GA. THK. SUS 304 S/S
✓ 02	LEG 支腿	∅38mm 16 GA. THK. SUS 304 S/S TUBE
✓ 03	ADJUSTABLE FOOT INSERT 可调节嵌入式底脚	LUI CHUEN KEE (CHN)
04	REINFORCEMENT 加固件	16 GA. THK. SUS 304 S/S
05	SINK BOWL 洗碗槽	16 GA. THK. SUS 304 S/S
06	SINK WASTE 废料槽	
✓ 07	S.S. CROSS RAIL 横梁	∅32mm 16 GA. THK. SUS 304 S/S TUBE
08	WALL MOUNTED BRACKET 壁装托架	16 GA. THK. SUS 304 S/S
09	UNDER SHELF 底架	18 GA. THK. SUS 304 S/S
10	MIXING FAUCET 混合龙头	
11	OVER SHELF 顶架	18 GA. THK. SUS 304 S/S
12	OUTER DOOR PANEL 外板	20 GA. THK. SUS 304 S/S
13	INNER DOOR PANEL 内板	22 GA. THK. SUS 304 S/S
14	CABINET BODY 柜身	20 GA. THK. SUS 304 S/S
15	CORNER BUMPER 拐角防护套	COLSON (CHN)
16	SWIVEL CASTOR 旋转角轮	GLOBE (CHN)
17	SOUND DEADEN MATERIAL 隔音材料	3mm THICKNESS
18	WALL FLASHING 防水面	20 GA. THK. SUS 304 S/S
19	CONDENSING UNIT 制冷机组	DANFOSS (CHN)
20	NOZZLE 排气口	∅25mm SUS 304 S/S TUBE

No:	Item No(款号):	Qty(数量):	No:	Item No(款号):	Qty(数量):

Remark(备注):

 M5

SPOT WELDED A THREADED SHAFT TO THE UNDERSIDE OF WORK TOP / SHELF. THEN USE UNITS TO FIX WITH THE REINFORCEMENT / BRACKETS

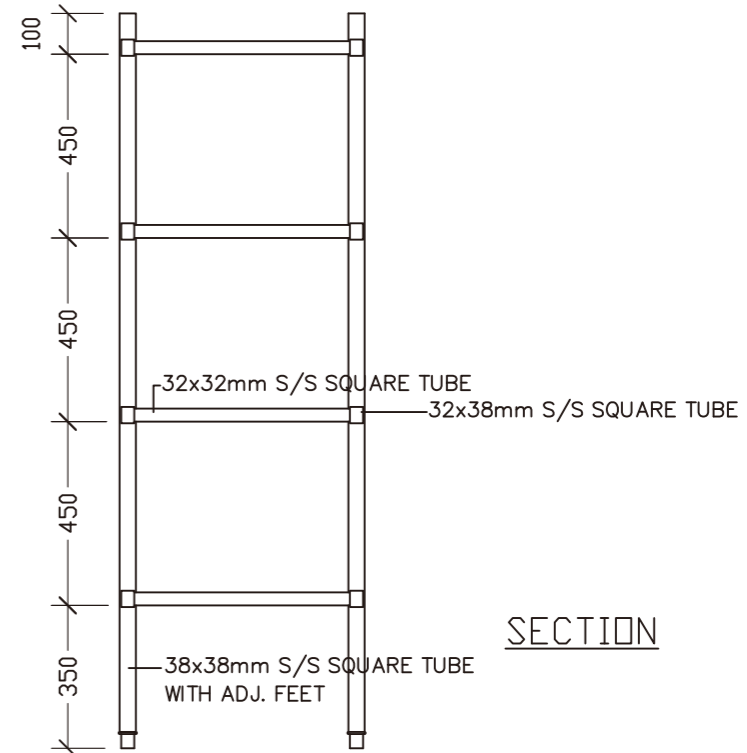
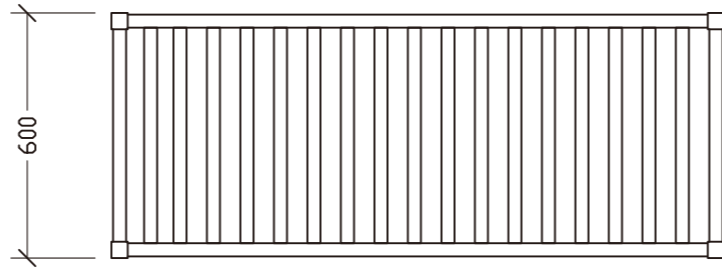
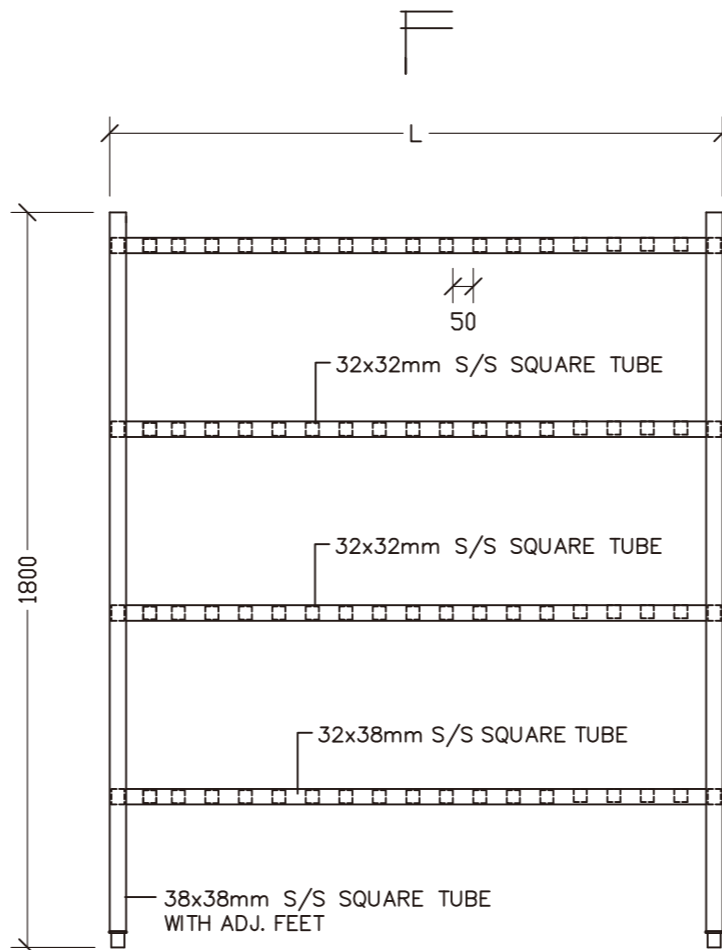

技术说明:				SKU:			
1.所有产品边缘不能有毛刺, 覆膜面不能刮花;				名称:	建德C40+潜水俱乐部厨房		
2.公差要求标准: 符合GB/T G3280-2015不锈钢冷轧钢板和钢带标准中PT.A的公称宽度要求;				材料:			
3.所有标注尺寸为外尺寸;				编制:		日期:	
4.未注膜面方向朝外。				审核:		日期:	
A						视角:	
版本		批准	日期			版本:	A

STAINLESS STEEL SHOP DRAWING (CUSTOM)

不锈钢件生产要求图

Product Description (产品说明):	Baking Oven Trolley (600*400 PAN)
	高身饼盆车 (600*400)
Model Type (模具型号):	MHP600 F01

No:	Parts(零部件):	Material Specification(用料标准):
01	COUNTER TOP 柜台面	16GA. THK. SUS 304 S/S
✓ 02	LEG 支腿	∅38mm 16 GA. THK. SUS 304 S/S TUBE
03	ADJUSTABLE FOOT INSERT 可调节嵌入式底脚	LUI CHUEN KEE (CHN)
✓ 04	REINFORCEMENT 加固件	16 GA. THK. SUS 304 S/S
05	SINK BOWL 洗碗槽	16 GA. THK. SUS 304 S/S
06	SINK WASTE 废料槽	
✓ 07	S.S. CROSS RAIL 横梁	∅32mm 16 GA. THK. SUS 304 S/S TUBE
08	WALL MOUNTED BRACKET 壁装托架	16 GA. THK. SUS 304 S/S
✓ 09	UNDER SHELF 底架	18 GA. THK. SUS 304 S/S
10	MIXING FAUCET 混合龙头	
11	OVER SHELF 顶架	18 GA. THK. SUS 304 S/S
12	OUTER DOOR PANEL 外板	20 GA. THK. SUS 304 S/S
13	INNER DOOR PANEL 内板	22 GA. THK. SUS 304 S/S
14	CABINET BODY 柜身	20 GA. THK. SUS 304 S/S
✓ 15	CORNER BUMPER 拐角防护套	COLSON (CHN)
✓ 16	SWIVEL CASTOR 旋转角轮	GLOBE (CHN)
17	SOUND DEADEN MATERIAL 隔音材料	3mm THICKNESS
18	WALL FLASHING 防水面	20 GA. THK. SUS 304 S/S
19	CONDENSING UNIT 制冷机组	DANFOSS (CHN)
20	NOZZLE 排气口	∅25mm SUS 304 S/S TUBE

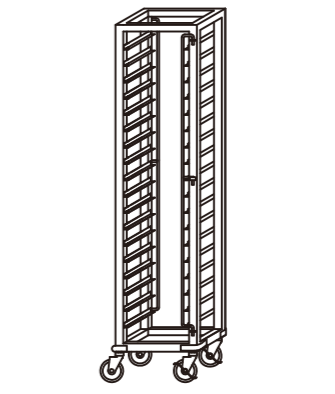
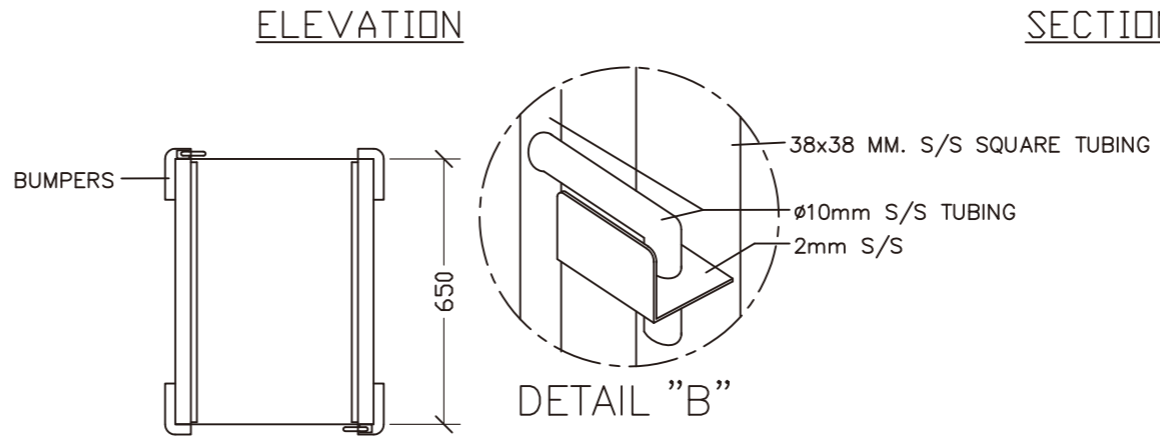
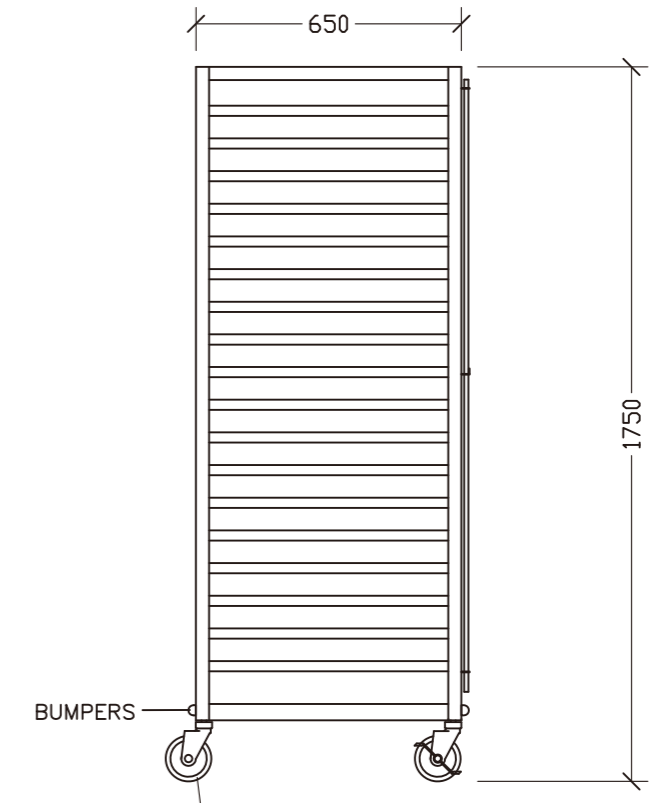
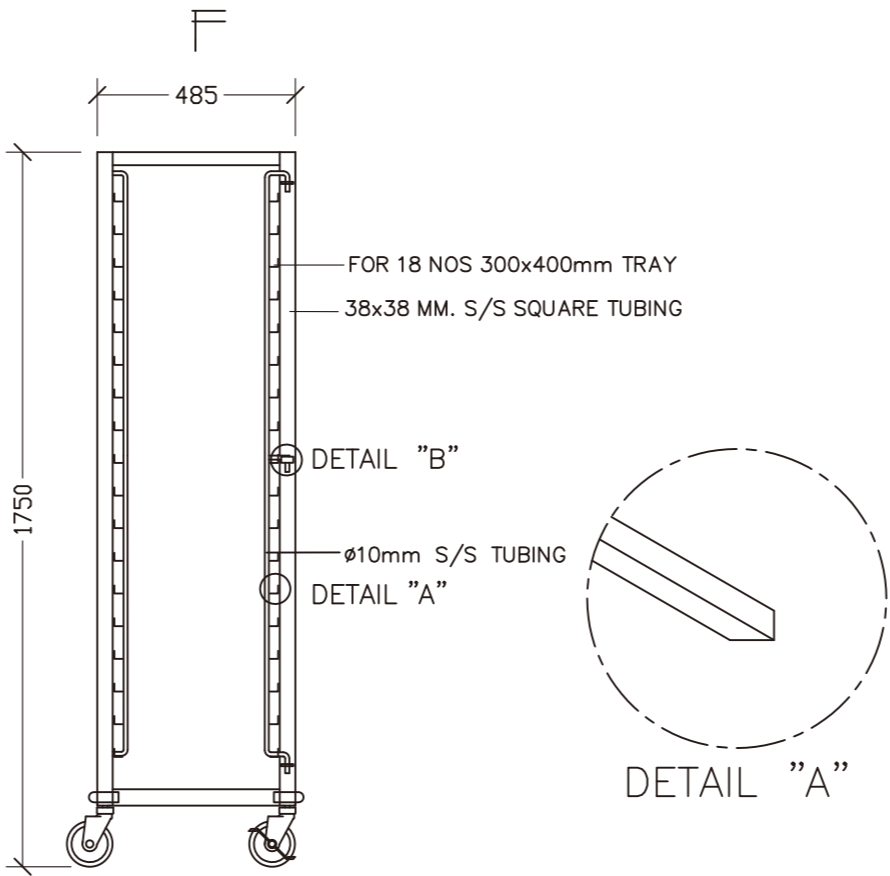

No:	Item No(款号):	Qty(数量):	No:	Item No(款号):	Qty(数量):

Remark(备注):

SPOT WELDED A THREADED SHAFT TO THE UNDERSIDE OF WORK TOP / SHELF. THEN USE UNITS TO FIX WITH THE REINFORCEMENT / BRACKETS

技术说明:				SKU:			
1.所有产品边缘不能有毛刺, 覆膜面不能刮花;				名称:	建德C40+潜水俱乐部厨房		
2.公差要求标准: 符合GB/T G3280-2015不锈钢冷轧钢板和钢带标准中PT.A的公称宽度要求;				材料:			
3.所有标注尺寸为外尺寸;				编制:		日期:	
4.未注膜面方向朝外。				审核:		日期:	
A						视角:	
版本		批准	日期			版本:	A

STAINLESS STEEL SHOP DRAWING (CUSTOM)

不锈钢件生产要求图

Product Description (产品说明):	Work Table W/Twin Sinks
	工作台连双星盆 (中间去水)
Model Type (模具型号):	STSH1 F06

No:	Parts(零部件):	Material Specification(用料标准):
✓ 01	COUNTER TOP 柜台面	16GA. THK. SUS 304 S/S
✓ 02	LEG 支腿	∅38mm 16 GA. THK. SUS 304 S/S TUBE
✓ 03	ADJUSTABLE FOOT INSERT 可调节嵌入式底脚	LUI CHUEN KEE (CHN)
✓ 04	REINFORCEMENT 加固件	16 GA. THK. SUS 304 S/S
✓ 05	SINK BOWL 洗碗槽	16 GA. THK. SUS 304 S/S
06	SINK WASTE 废料槽	
✓ 07	S.S. CROSS RAIL 横梁	∅32mm 16 GA. THK. SUS 304 S/S TUBE
08	WALL MOUNTED BRACKET 壁装托架	16 GA. THK. SUS 304 S/S
09	UNDER SHELF 底架	18 GA. THK. SUS 304 S/S
✓ 10	MIXING FAUCET 混合龙头	
11	OVER SHELF 顶架	18 GA. THK. SUS 304 S/S
12	OUTER DOOR PANEL 外板	20 GA. THK. SUS 304 S/S
13	INNER DOOR PANEL 内板	22 GA. THK. SUS 304 S/S
14	CABINET BODY 柜身	20 GA. THK. SUS 304 S/S
15	CORNER BUMPER 拐角防护套	COLSON (CHN)
16	SWIVEL CASTOR 旋转角轮	GLOBE (CHN)
17	SOUND DEADEN MATERIAL 隔音材料	3mm THICKNESS
18	WALL FLASHING 防水面	20 GA. THK. SUS 304 S/S
19	CONDENSING UNIT 制冷机组	DANFOSS (CHN)
20	NOZZLE 排气口	∅25mm SUS 304 S/S TUBE

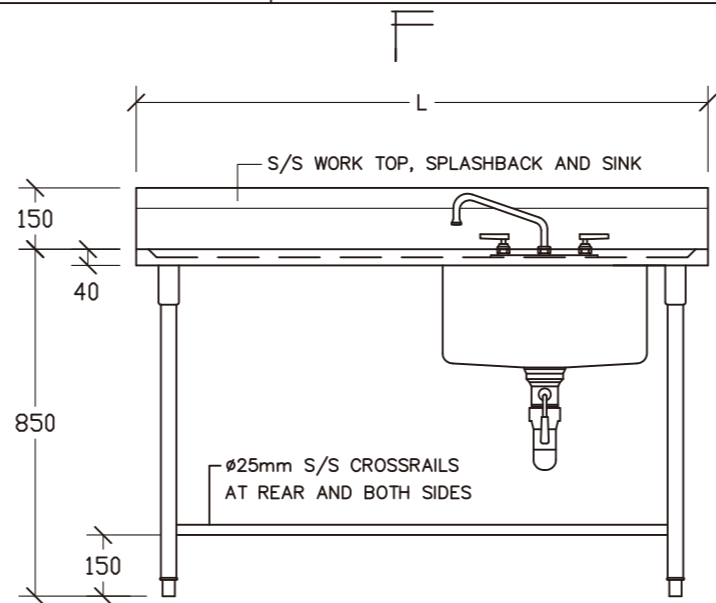

ELEVATION

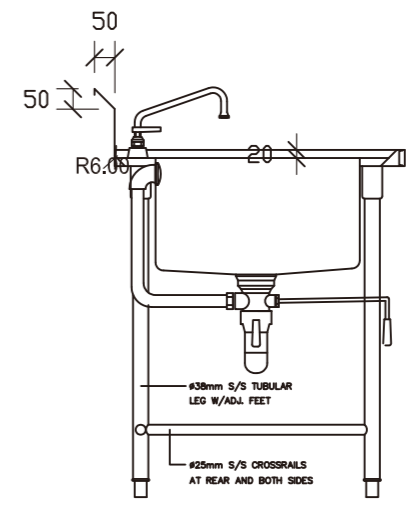

SECTION

No:	Item No(款号):	Qty(数量):	No:	Item No(款号):	Qty(数量):

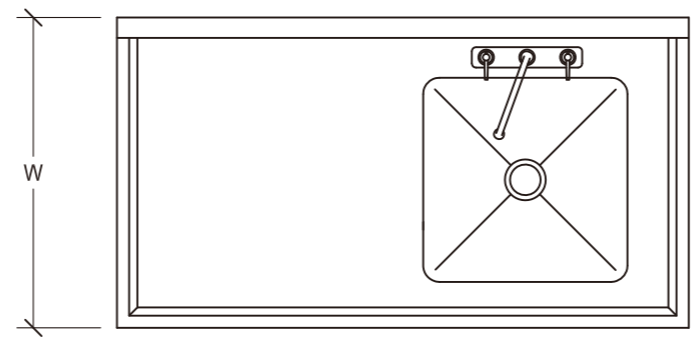

PLAN

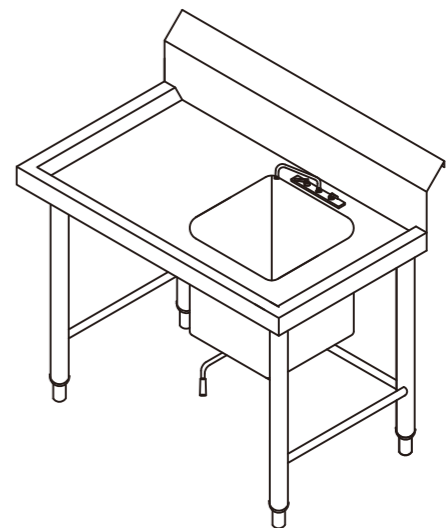

ISOMETRIC VIEW

Remark(备注):

 M5

SPOT WELDED A THREADED SHAFT TO THE UNDERSIDE OF WORK TOP / SHELF. THEN USE UNITS TO FIX WITH THE REINFORCEMENT / BRACKETS

技术说明:				SKU:			
1.所有产品边缘不能有毛刺, 覆膜面不能刮花;				名称:	建德C40+潜水俱乐部厨房		
2.公差要求标准: 符合GB/T G3280-2015不锈钢冷轧钢板和钢带标准中PT.A的公称宽度要求;				材料:			
3.所有标注尺寸为外尺寸;				编制:		日期:	
4.未注膜面方向朝外。				审核:		日期:	
A						视角:	
版本		批准	日期			版本:	A

STAINLESS STEEL SHOP DRAWING (CUSTOM)

不锈钢件生产要求图

Product Description (产品说明):	4-Tier Square Tube Storage Shelving
	四层通架
Model Type (模具型号):	JFG4 F08

No:	Parts(零部件):	Material Specification(用料标准):
01	COUNTER TOP 柜台面	16GA. THK. SUS 304 S/S
✓ 02	LEG 支腿	∅38mm 16 GA. THK. SUS 304 S/S TUBE
✓ 03	ADJUSTABLE FOOT INSERT 可调节嵌入式底脚	LUI CHUEN KEE (CHN)
04	REINFORCEMENT 加固件	16 GA. THK. SUS 304 S/S
05	SINK BOWL 洗碗槽	16 GA. THK. SUS 304 S/S
06	SINK WASTE 废料槽	
✓ 07	S.S. CROSS RAIL 横梁	∅32mm 16 GA. THK. SUS 304 S/S TUBE
08	WALL MOUNTED BRACKET 壁装托架	16 GA. THK. SUS 304 S/S
09	UNDER SHELF 底架	18 GA. THK. SUS 304 S/S
10	MIXING FAUCET 混合龙头	
11	OVER SHELF 顶架	18 GA. THK. SUS 304 S/S
12	OUTER DOOR PANEL 外板	20 GA. THK. SUS 304 S/S
13	INNER DOOR PANEL 内板	22 GA. THK. SUS 304 S/S
14	CABINET BODY 柜身	20 GA. THK. SUS 304 S/S
15	CORNER BUMPER 拐角防护套	COLSON (CHN)
16	SWIVEL CASTOR 旋转角轮	GLOBE (CHN)
17	SOUND DEADEN MATERIAL 隔音材料	3mm THICKNESS
18	WALL FLASHING 防水面	20 GA. THK. SUS 304 S/S
19	CONDENSING UNIT 制冷机组	DANFOSS (CHN)
20	NOZZLE 排气口	∅25mm SUS 304 S/S TUBE

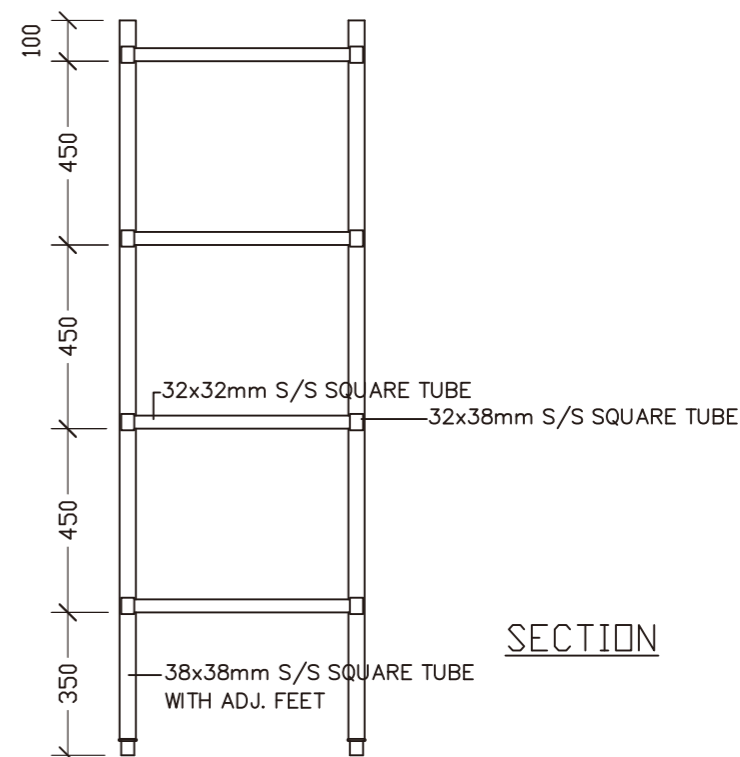
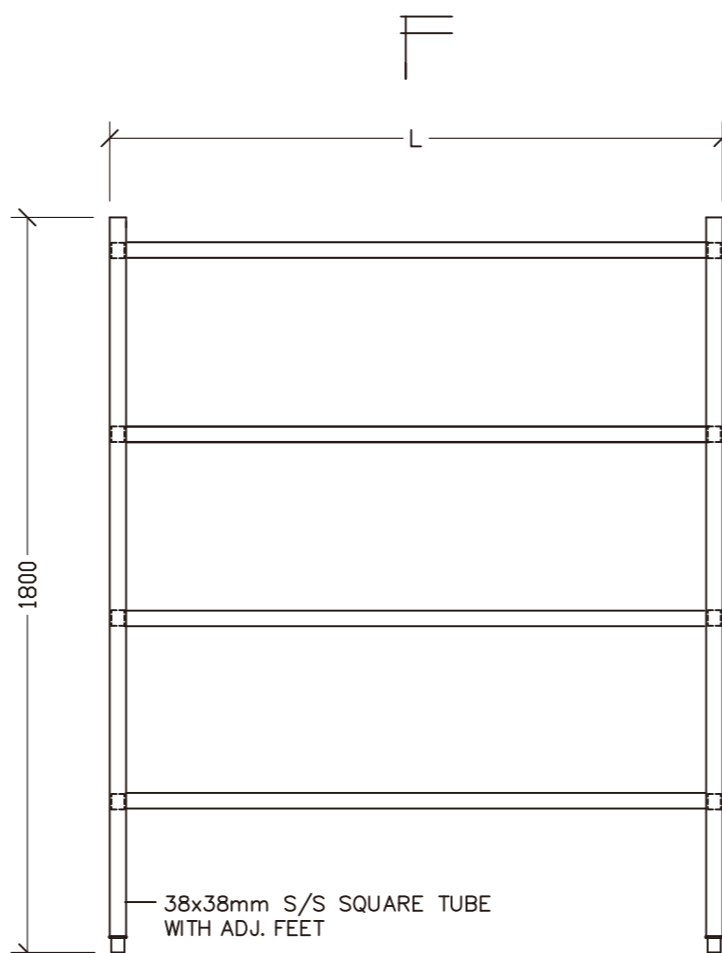

ELEVATION

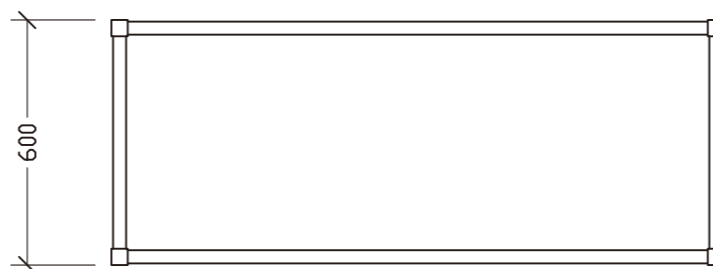

PLAN

No:	Item No(款号):	Qty(数量):	No:	Item No(款号):	Qty(数量):

Remark(备注):



M5

SPOT WELDED A THREADED SHAFT TO THE UNDERSIDE OF WORK TOP / SHELF. THEN USE UNITS TO FIX WITH THE REINFORCEMENT / BRACKETS

技术说明:				SKU:			
1.所有产品边缘不能有毛刺, 覆膜面不能刮花;				名称:	建德C40+潜水俱乐部厨房		
2.公差要求标准: 符合GB/T G3280-2015不锈钢冷轧钢板和钢带标准中PT.A的公称宽度要求;				材料:			
3.所有标注尺寸为外尺寸;				编制:		日期:	
4.未注膜面方向朝外。				审核:		日期:	
A						视角:	☉
版本			批准	日期		版本:	A

STAINLESS STEEL SHOP DRAWING (CUSTOM)

不锈钢件生产要求图

Product Description (产品说明):	Cabinet
	丝网门立柜
Model Type (模具型号):	CUSF F09

No:	Parts(零部件):	Material Specification(用料标准):
✓ 01	COUNTER TOP 柜台面	16GA. THK. SUS 304 S/S
02	LEG 支腿	∅38mm 16 GA. THK. SUS 304 S/S TUBE
✓ 03	ADJUSTABLE FOOT INSERT 可调节嵌入式底脚	LUI CHUEN KEE (CHN)
✓ 04	REINFORCEMENT 加固件	16 GA. THK. SUS 304 S/S
05	SINK BOWL 洗碗槽	16 GA. THK. SUS 304 S/S
06	SINK WASTE 废料槽	
07	S.S. CROSS RAIL 横梁	∅32mm 16 GA. THK. SUS 304 S/S TUBE
08	WALL MOUNTED BRACKET 壁装托架	16 GA. THK. SUS 304 S/S
✓ 09	UNDER SHELF 底架	18 GA. THK. SUS 304 S/S
10	MIXING FAUCET 混合龙头	
11	OVER SHELF 顶架	18 GA. THK. SUS 304 S/S
✓ 12	OUTER DOOR PANEL 外板	20 GA. THK. SUS 304 S/S
✓ 13	INNER DOOR PANEL 内板	22 GA. THK. SUS 304 S/S
✓ 14	CABINET BODY 柜身	20 GA. THK. SUS 304 S/S
15	CORNER BUMPER 拐角防护套	COLSON (CHN)
16	SWIVEL CASTOR 旋转角轮	GLOBE (CHN)
17	SOUND DEADEN MATERIAL 隔音材料	3mm THICKNESS
18	WALL FLASHING 防水面	20 GA. THK. SUS 304 S/S
19	CONDENSING UNIT 制冷机组	DANFOSS (CHN)
20	NOZZLE 排气口	∅25mm SUS 304 S/S TUBE

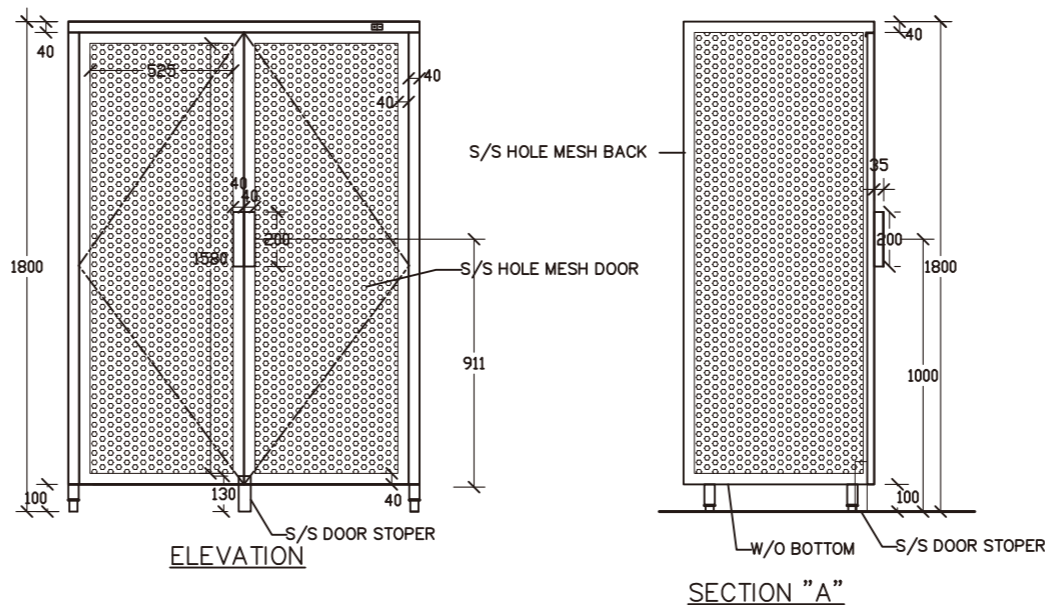

No:	Item No(款号):	Qty(数量):	No:	Item No(款号):	Qty(数量):

Remark(备注):

 M5

SPOT WELDED A THREADED SHAFT TO THE UNDERSIDE OF WORK TOP / SHELF. THEN USE UNITS TO FIX WITH THE REINFORCEMENT / BRACKETS

技术说明:				SKU:			
1.所有产品边缘不能有毛刺, 覆膜面不能刮花;				名称:	建德C40+潜水俱乐部厨房		
2.公差要求标准: 符合GB/T G3280-2015不锈钢冷轧钢板和钢带标准中PT.A的公称宽度要求;				材料:			
3.所有标注尺寸为外尺寸;				编制:		日期:	
4.未注膜面方向朝外。				审核:		日期:	
A						视角:	
版本		批准	日期			版本:	A

STAINLESS STEEL SHOP DRAWING (CUSTOM)

不锈钢件生产要求图

Product Description (产品说明):	Hot Palte Cabinet
	操作台
Model Type (模具型号):	CHC-0 F10

No:	Parts(零部件):	Material Specfication(用料标准):
✓ 01	COUNTER TOP 柜台面	16GA. THK. SUS 304 S/S
02	LEG 支腿	Ø38mm 16 GA. THK. SUS 304 S/S TUBE
✓ 03	ADJUSTABLE FOOT INSERT 可调节嵌入式底脚	LUI CHUEN KEE (CHN)
✓ 04	REINFORCEMENT 加固件	16 GA. THK. SUS 304 S/S
05	SINK BOWL 洗碗槽	16 GA. THK. SUS 304 S/S
06	SINK WASTE 废料槽	
07	S.S. CROSS RAIL 横梁	Ø32mm 16 GA. THK. SUS 304 S/S TUBE
08	WALL MOUNTED BRACKET 壁装托架	16 GA. THK. SUS 304 S/S
✓ 09	UNDER SHELF 底架	18 GA. THK. SUS 304 S/S
10	MIXING FAUCET 混合龙头	
11	OVER SHELF 顶架	18 GA. THK. SUS 304 S/S
✓ 12	OUTER DOOR PANEL 外板	20 GA. THK. SUS 304 S/S
✓ 13	INNER DOOR PANEL 内板	22 GA. THK. SUS 304 S/S
✓ 14	CABINET BODY 柜身	20 GA. THK. SUS 304 S/S
15	CORNER BUMPER 拐角防护套	COLSON (CHN)
16	SWIVEL CASTOR 旋转角轮	GLOBE (CHN)
17	SOUND DEADEN MATERIAL 隔音材料	3mm THICKNESS
18	WALL FLASHING 防水面	20 GA. THK. SUS 304 S/S
19	CONDENSING UNIT 制冷机组	DANFOSS (CHN)
20	NOZZLE 排气口	Ø25mm SUS 304 S/S TUBE

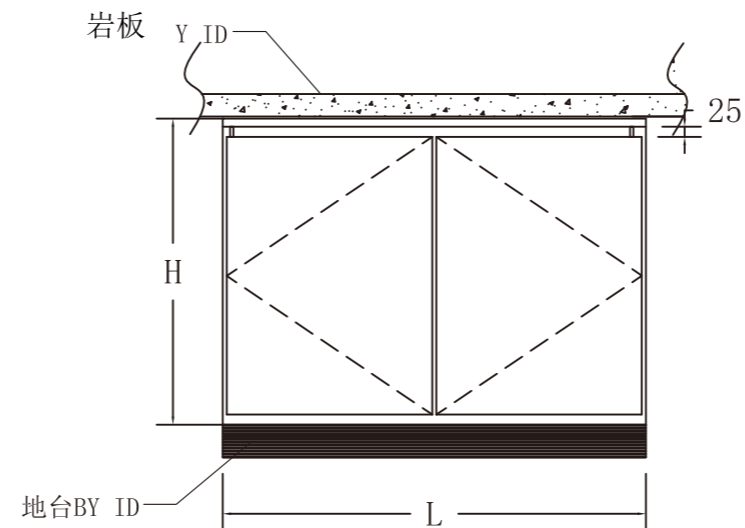

ELEVATION

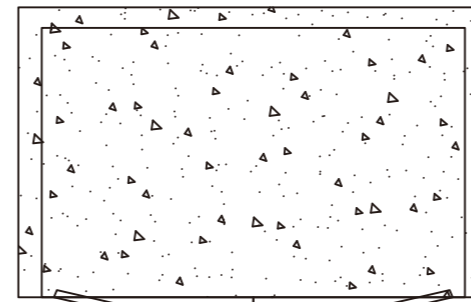
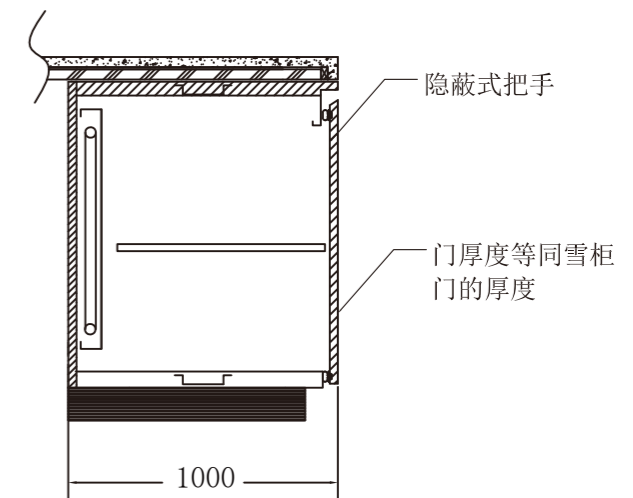

PLAN

No:	Item No(款号):	Qty(数量):	No:	Item No(款号):	Qty(数量):

Remark(备注):



SPOT WELDED A THREADED SHAFT TO THE UNDERSIDE OF WORK TOP / SHELF. THEN USE UNITS TO FIX WITH THE REINFORCEMENT / BRACKETS

技术说明:				SKU:			
1.所有产品边缘不能有毛刺, 覆膜面不能刮花;				名称:	建德C40+潜水俱乐部厨房		
2.公差要求标准: 符合GB/T G3280-2015不锈钢冷轧钢板和钢带标准中PT.A的公称宽度要求;				材料:			
3.所有标注尺寸为外尺寸;				编制:		日期:	
4.未注膜面方向朝外。				审核:		日期:	
A						视角:	☉ ☒
版本		批准	日期			版本:	A

STAINLESS STEEL SHOP DRAWING (CUSTOM)

不锈钢件生产要求图

Product Description (产品说明):	Double Ceiling Mounted Shelving W/1/6 GN
	吊天花双层架连GN盆
Model Type (模具型号):	JBC2-GN F11

No:	Parts(零部件):	Material Specification(用料标准):
01	COUNTER TOP 柜台面	16GA. THK. SUS 304 S/S
✓ 02	LEG 支腿	∅38mm 16 GA. THK. SUS 304 S/S TUBE
03	ADJUSTABLE FOOT INSERT 可调节嵌入式底脚	LUI CHUEN KEE (CHN)
✓ 04	REINFORCEMENT 加固件	16 GA. THK. SUS 304 S/S
05	SINK BOWL 洗碗槽	16 GA. THK. SUS 304 S/S
06	SINK WASTE 废料槽	
07	S.S. CROSS RAIL 横梁	∅32mm 16 GA. THK. SUS 304 S/S TUBE
08	WALL MOUNTED BRACKET 壁挂托架	16 GA. THK. SUS 304 S/S
✓ 09	UNDER SHELF 底架	18 GA. THK. SUS 304 S/S
10	MIXING FAUCET 混合龙头	
✓ 11	OVER SHELF 顶架	18 GA. THK. SUS 304 S/S
12	OUTER DOOR PANEL 外板	20 GA. THK. SUS 304 S/S
13	INNER DOOR PANEL 内板	22 GA. THK. SUS 304 S/S
14	CABINET BODY 柜身	20 GA. THK. SUS 304 S/S
15	CORNER BUMPER 拐角防护套	COLSON (CHN)
16	SWIVEL CASTOR 旋转角轮	GLOBE (CHN)
17	SOUND DEADEN MATERIAL 隔音材料	3mm THICKNESS
18	WALL FLASHING 防水面	20 GA. THK. SUS 304 S/S
19	CONDENSING UNIT 制冷机组	DANFOSS (CHN)
20	NOZZLE 排气口	∅25mm SUS 304 S/S TUBE

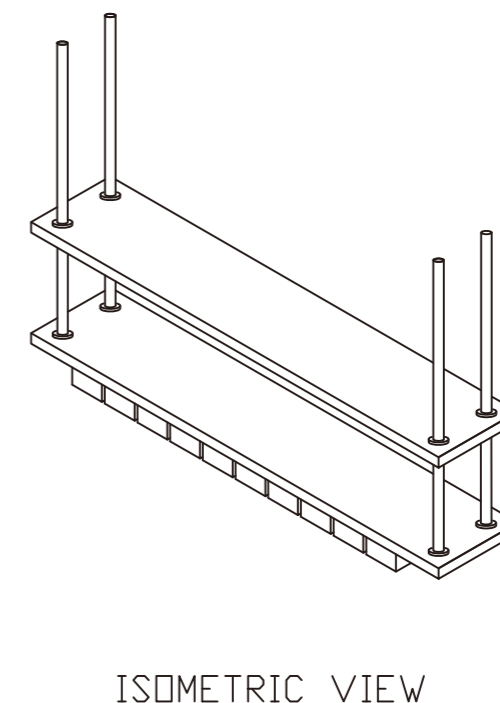
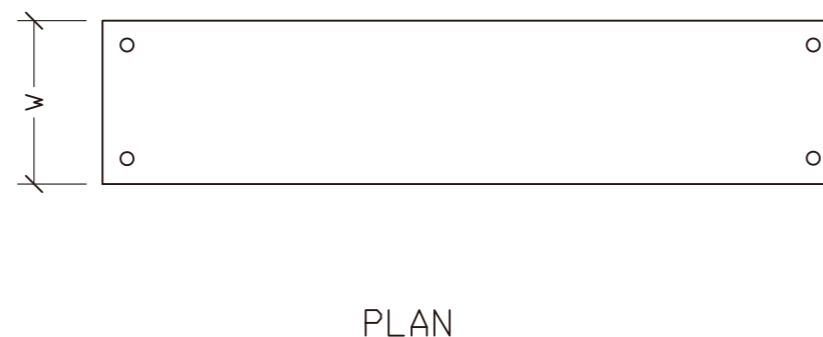
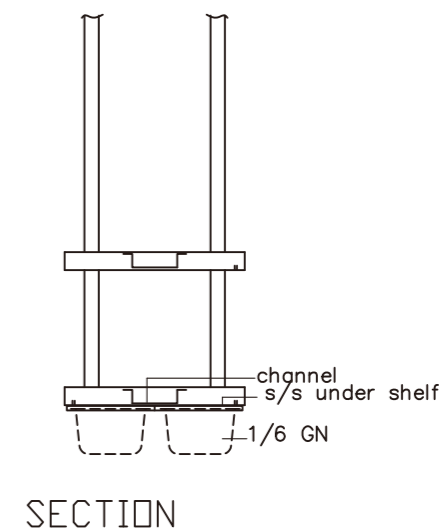
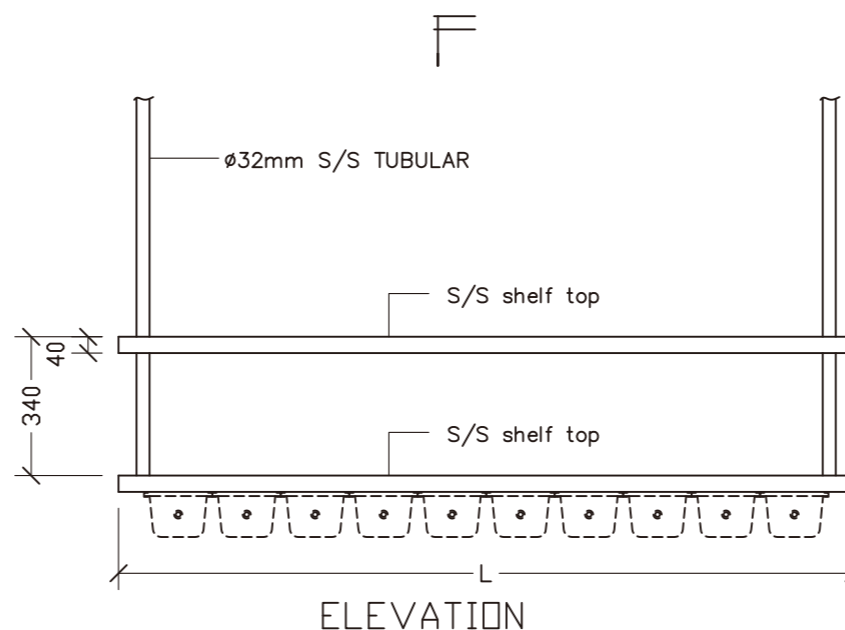

No:	Item No(款号):	Qty(数量):	No:	Item No(款号):	Qty(数量):

Remark(备注):



SPOT WELDED A THREADED SHAFT TO THE UNDERSIDE OF WORK TOP / SHELF. THEN USE UNITS TO FIX WITH THE REINFORCEMENT / BRACKETS

				技术说明:	SKU:					
				1.所有产品边缘不能有毛刺, 覆膜面不能刮花;	名称:	建德C40+潜水俱乐部厨房				
				2.公差要求标准: 符合GB/T G3280-2015不锈钢冷轧钢板和钢带标准中PT.A的公称宽度要求;	材料:					
				3.所有标注尺寸为外尺寸;	编制:			日期:		
				4.未注膜面方向朝外。	审核:			日期:		
A				批准	日期			视角:	☉ ☒	
版本				日期			版本:	A		

STAINLESS STEEL SHOP DRAWING (CUSTOM)

不锈钢件生产要求图

Product Description (产品说明):	ELE.RICE Warming Cart
	电热暖饭车
Model Type (模具型号):	MHR F12

No:	Parts(零部件):	Material Specification(用料标准):
✓ 01	COUNTER TOP 柜台面	16GA. THK. SUS 304 S/S
02	LEG 支腿	∅38mm 16 GA. THK. SUS 304 S/S TUBE
03	ADJUSTABLE FOOT INSERT 可调节嵌入式底脚	LUI CHUEN KEE (CHN)
✓ 04	REINFORCEMENT 加固件	16 GA. THK. SUS 304 S/S
✓ 05	SINK BOWL 洗碗槽	16 GA. THK. SUS 304 S/S
06	SINK WASTE 废料槽	
07	S.S. CROSS RAIL 横梁	∅32mm 16 GA. THK. SUS 304 S/S TUBE
08	WALL MOUNTED BRACKET 壁装托架	16 GA. THK. SUS 304 S/S
09	UNDER SHELF 底架	18 GA. THK. SUS 304 S/S
10	MIXING FAUCET 混合龙头	
11	OVER SHELF 顶架	18 GA. THK. SUS 304 S/S
✓ 12	OUTER DOOR PANEL 外板	20 GA. THK. SUS 304 S/S
✓ 13	INNER DOOR PANEL 内板	22 GA. THK. SUS 304 S/S
✓ 14	CABINET BODY 柜身	20 GA. THK. SUS 304 S/S
✓ 15	CORNER BUMPER 拐角防护套	COLSON (CHN)
✓ 16	SWIVEL CASTOR 旋转角轮	GLOBE (CHN)
17	SOUND DEADEN MATERIAL 隔音材料	3mm THICKNESS
18	WALL FLASHING 防水面	20 GA. THK. SUS 304 S/S
19	CONDENSING UNIT 制冷机组	DANFOSS (CHN)
20	NOZZLE 排气口	∅25mm SUS 304 S/S TUBE

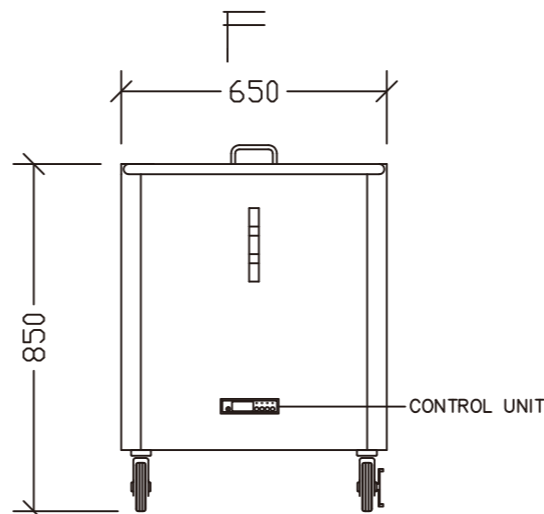

ELEVATION

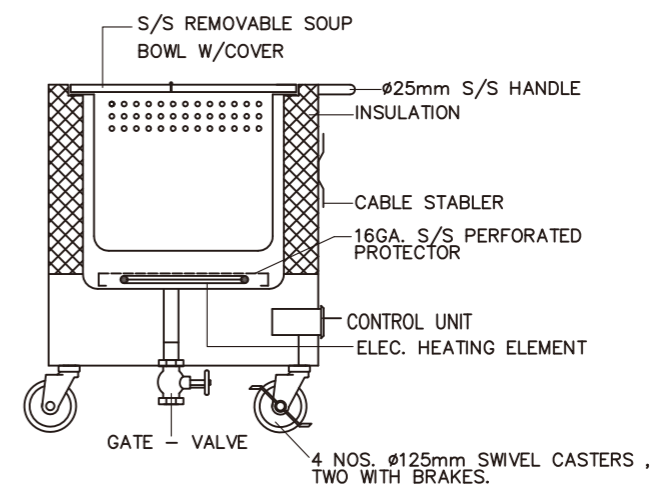

SECTION

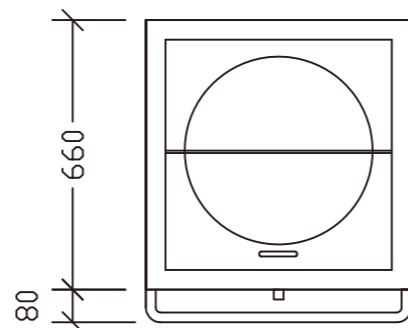

PLAN

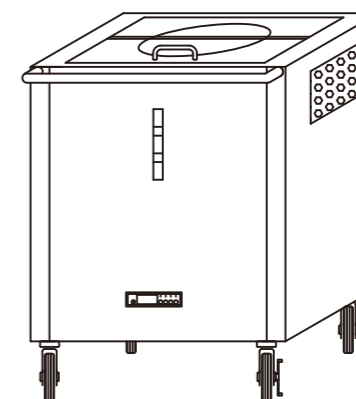

ISOMETRIC VIEW

No:	Item No(款号):	Qty(数量):	No:	Item No(款号):	Qty(数量):

Remark(备注):



SPOT WELDED A THREADED SHAFT TO THE UNDERSIDE OF WORK TOP / SHELF. THEN USE UNITS TO FIX WITH THE REINFORCEMENT / BRACKETS

技术说明:				SKU:			
1.所有产品边缘不能有毛刺, 覆膜面不能刮花;				名称:	建德C40+潜水俱乐部厨房		
2.公差要求标准: 符合GB/T G3280-2015不锈钢冷轧钢板和钢带标准中PT.A的公称宽度要求;				材料:			
3.所有标注尺寸为外尺寸;				编制:		日期:	
4.未注膜面方向朝外。				审核:		日期:	
A						视角:	☉ ☒
版本		批准	日期			版本:	A

STAINLESS STEEL SHOP DRAWING (CUSTOM)

不锈钢件生产要求图

Product Description (产品说明):	Hot Palte Cabinet
	操作台
Model Type (模具型号):	CHC-0 F13

No:	Parts(零部件):	Material Specfication(用料标准):
✓ 01	COUNTER TOP 柜台面	16GA. THK. SUS 304 S/S
02	LEG 支腿	Ø38mm 16 GA. THK. SUS 304 S/S TUBE
✓ 03	ADJUSTABLE FOOT INSERT 可调节嵌入式底脚	LUI CHUEN KEE (CHN)
✓ 04	REINFORCEMENT 加固件	16 GA. THK. SUS 304 S/S
05	SINK BOWL 洗碗槽	16 GA. THK. SUS 304 S/S
06	SINK WASTE 废料槽	
07	S.S. CROSS RAIL 横梁	Ø32mm 16 GA. THK. SUS 304 S/S TUBE
08	WALL MOUNTED BRACKET 壁装托架	16 GA. THK. SUS 304 S/S
✓ 09	UNDER SHELF 底架	18 GA. THK. SUS 304 S/S
10	MIXING FAUCET 混合龙头	
11	OVER SHELF 顶架	18 GA. THK. SUS 304 S/S
✓ 12	OUTER DOOR PANEL 外板	20 GA. THK. SUS 304 S/S
✓ 13	INNER DOOR PANEL 内板	22 GA. THK. SUS 304 S/S
✓ 14	CABINET BODY 柜身	20 GA. THK. SUS 304 S/S
15	CORNER BUMPER 拐角防护套	COLSON (CHN)
16	SWIVEL CASTOR 旋转角轮	GLOBE (CHN)
17	SOUND DEADEN MATERIAL 隔音材料	3mm THICKNESS
18	WALL FLASHING 防水面	20 GA. THK. SUS 304 S/S
19	CONDENSING UNIT 制冷机组	DANFOSS (CHN)
20	NOZZLE 排气口	Ø25mm SUS 304 S/S TUBE

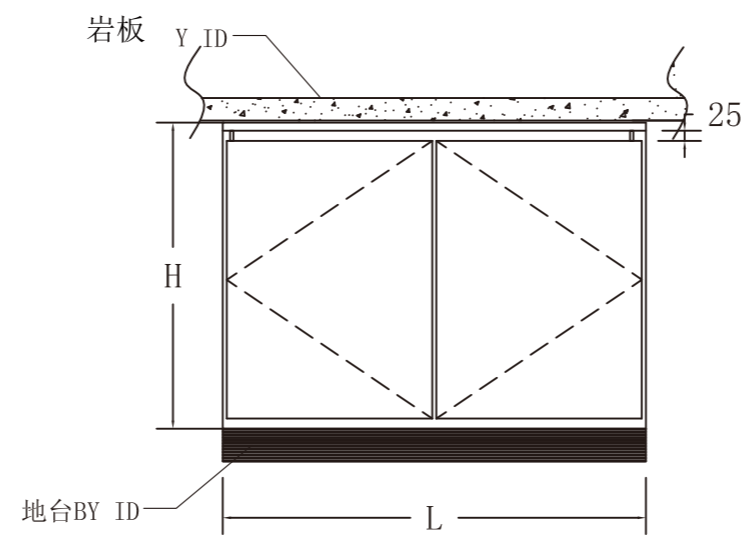

ELEVATION

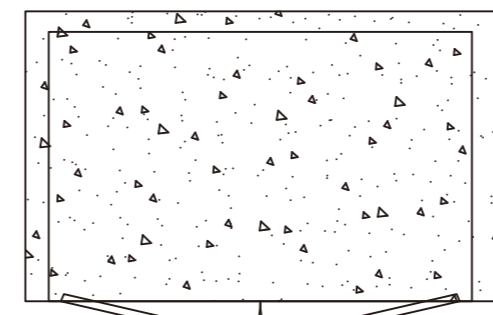
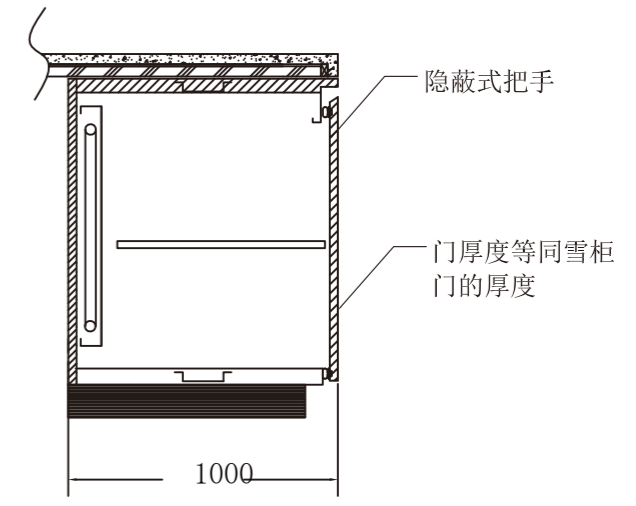

PLAN

No:	Item No(款号):	Qty(数量):	No:	Item No(款号):	Qty(数量):

Remark(备注):

 M5

SPOT WELDED A THREADED SHAFT TO THE UNDERSIDE OF WORK TOP / SHELF. THEN USE UNITS TO FIX WITH THE REINFORCEMENT / BRACKETS

技术说明:				SKU:			
1.所有产品边缘不能有毛刺, 覆膜面不能刮花;				名称:	建德C40+潜水俱乐部厨房		
2.公差要求标准: 符合GB/T G3280-2015不锈钢冷轧钢板和钢带标准中PT.A的公称宽度要求;				材料:			
3.所有标注尺寸为外尺寸;				编制:		日期:	
4.未注膜面方向朝外。				审核:		日期:	
A						视角:	
版本		批准	日期			版本:	A

STAINLESS STEEL SHOP DRAWING (CUSTOM)

不锈钢件生产要求图

Product Description (产品说明):	Double Ceiling Mounted Shelving W/1/6 GN
	吊天花双层架连GN盆
Model Type (模具型号):	JBC2-GN F14

No:	Parts(零部件):	Material Specification(用料标准):
01	COUNTER TOP 柜台面	16GA. THK. SUS 304 S/S
✓ 02	LEG 支腿	∅38mm 16 GA. THK. SUS 304 S/S TUBE
03	ADJUSTABLE FOOT INSERT 可调节嵌入式底脚	LUI CHUEN KEE (CHN)
✓ 04	REINFORCEMENT 加固件	16 GA. THK. SUS 304 S/S
05	SINK BOWL 洗碗槽	16 GA. THK. SUS 304 S/S
06	SINK WASTE 废料槽	
07	S.S. CROSS RAIL 横梁	∅32mm 16 GA. THK. SUS 304 S/S TUBE
08	WALL MOUNTED BRACKET 壁挂托架	16 GA. THK. SUS 304 S/S
✓ 09	UNDER SHELF 底架	18 GA. THK. SUS 304 S/S
10	MIXING FAUCET 混合龙头	
✓ 11	OVER SHELF 顶架	18 GA. THK. SUS 304 S/S
12	OUTER DOOR PANEL 外板	20 GA. THK. SUS 304 S/S
13	INNER DOOR PANEL 内板	22 GA. THK. SUS 304 S/S
14	CABINET BODY 柜身	20 GA. THK. SUS 304 S/S
15	CORNER BUMPER 拐角防护套	COLSON (CHN)
16	SWIVEL CASTOR 旋转角轮	GLOBE (CHN)
17	SOUND DEADEN MATERIAL 隔音材料	3mm THICKNESS
18	WALL FLASHING 防水面	20 GA. THK. SUS 304 S/S
19	CONDENSING UNIT 制冷机组	DANFOSS (CHN)
20	NOZZLE 排气口	∅25mm SUS 304 S/S TUBE

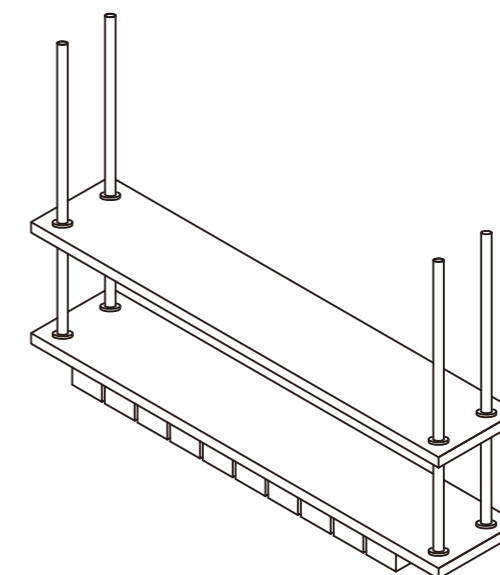
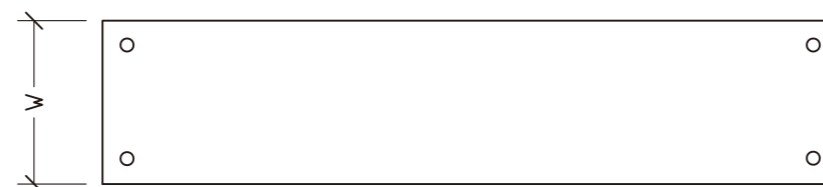
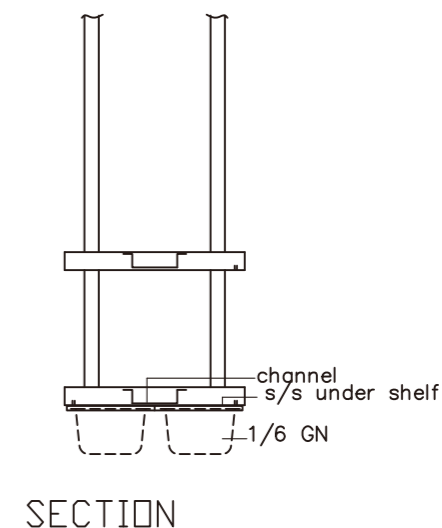
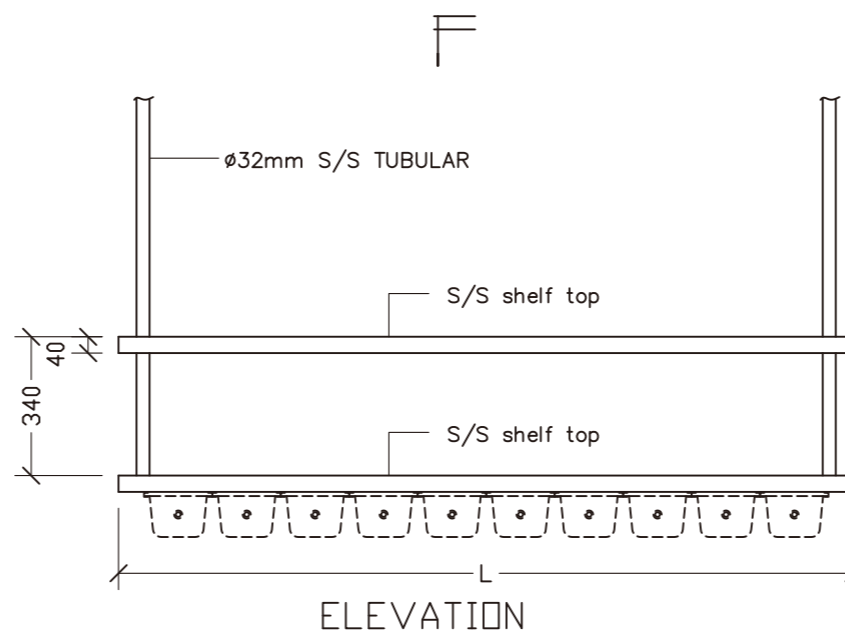

No:	Item No(款号):	Qty(数量):	No:	Item No(款号):	Qty(数量):

Remark(备注):



SPOT WELDED A THREADED SHAFT TO THE UNDERSIDE OF WORK TOP / SHELF. THEN USE UNITS TO FIX WITH THE REINFORCEMENT / BRACKETS

技术说明:
 1.所有产品边缘不能有毛刺, 覆膜面不能刮花;
 2.公差要求标准: 符合GB/T G3280-2015不锈钢冷轧钢板和钢带标准中PT.A的公称宽度要求;
 3.所有标注尺寸为外尺寸;
 4.未注膜面方向朝外。

SKU:		日期:		视角:	⊕
名称:	建德C40+潜水俱乐部厨房	日期:		版本:	A
材料:					
编制:					
审核:					

A					
版本			批准	日期	

STAINLESS STEEL SHOP DRAWING (CUSTOM)

不锈钢件生产要求图

Product Description (产品说明):	Work Table W/Twin Sinks
	工作台连双星盆 (中间去水)
Model Type (模具型号):	STSH1 G03

No:	Parts(零部件):	Material Specification(用料标准):
✓ 01	COUNTER TOP 柜台面	16GA. THK. SUS 304 S/S
✓ 02	LEG 支腿	∅38mm 16 GA. THK. SUS 304 S/S TUBE
✓ 03	ADJUSTABLE FOOT INSERT 可调节嵌入式底脚	LUI CHUEN KEE (CHN)
✓ 04	REINFORCEMENT 加固件	16 GA. THK. SUS 304 S/S
✓ 05	SINK BOWL 洗碗槽	16 GA. THK. SUS 304 S/S
06	SINK WASTE 废料槽	
✓ 07	S.S. CROSS RAIL 横梁	∅32mm 16 GA. THK. SUS 304 S/S TUBE
08	WALL MOUNTED BRACKET 壁装托架	16 GA. THK. SUS 304 S/S
09	UNDER SHELF 底架	18 GA. THK. SUS 304 S/S
✓ 10	MIXING FAUCET 混合龙头	
11	OVER SHELF 顶架	18 GA. THK. SUS 304 S/S
12	OUTER DOOR PANEL 外板	20 GA. THK. SUS 304 S/S
13	INNER DOOR PANEL 内板	22 GA. THK. SUS 304 S/S
14	CABINET BODY 柜身	20 GA. THK. SUS 304 S/S
15	CORNER BUMPER 拐角防护套	COLSON (CHN)
16	SWIVEL CASTOR 旋转角轮	GLOBE (CHN)
17	SOUND DEADEN MATERIAL 隔音材料	3mm THICKNESS
18	WALL FLASHING 防水面	20 GA. THK. SUS 304 S/S
19	CONDENSING UNIT 制冷机组	DANFOSS (CHN)
20	NOZZLE 排气口	∅25mm SUS 304 S/S TUBE

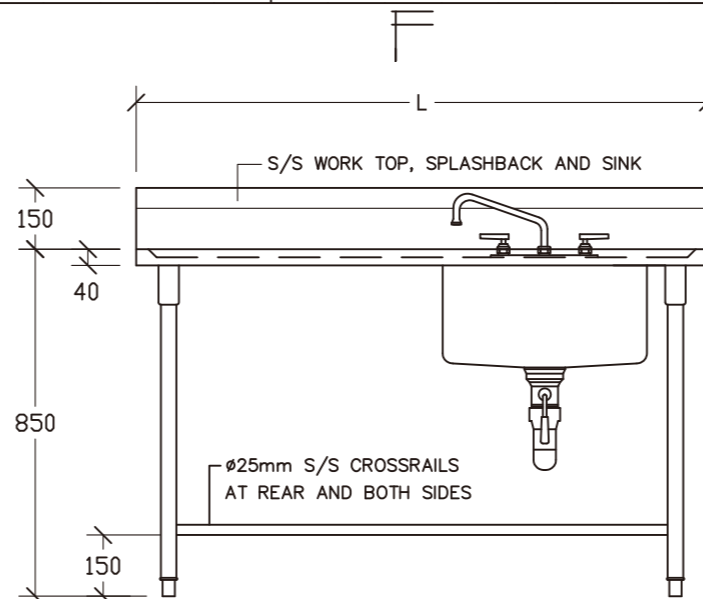

ELEVATION

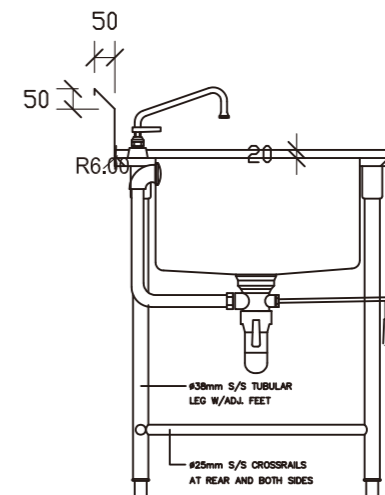

SECTION

No:	Item No(款号):	Qty(数量):	No:	Item No(款号):	Qty(数量):

Remark(备注):



SPOT WELDED A THREADED SHAFT TO THE UNDERSIDE OF WORK TOP / SHELF. THEN USE UNITS TO FIX WITH THE REINFORCEMENT / BRACKETS

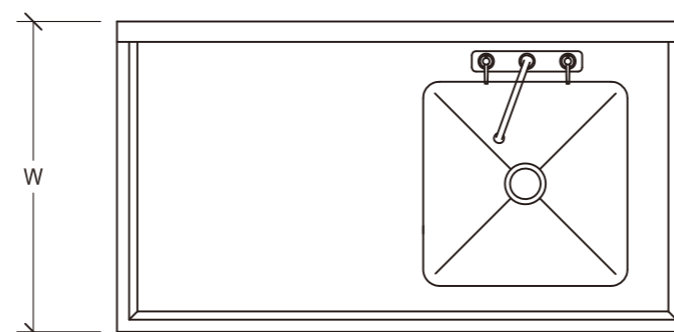

PLAN

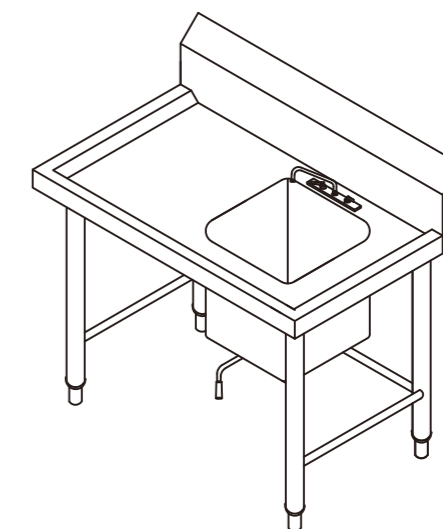

ISOMETRIC VIEW

技术说明:				SKU:			
1.所有产品边缘不能有毛刺, 覆膜面不能刮花;				名称:	建德C40+潜水俱乐部厨房		
2.公差要求标准: 符合GB/T G3280-2015不锈钢冷轧钢板和钢带标准中PT.A的公称宽度要求;				材料:			
3.所有标注尺寸为外尺寸;				编制:		日期:	
4.未注膜面方向朝外。				审核:		日期:	
A						视角:	☉
版本		批准	日期			版本:	A

STAINLESS STEEL SHOP DRAWING (CUSTOM)

不锈钢件生产要求图

Product Description (产品说明):	Work Table W/Under Shelf
	工作台下置层板
Model Type (模具型号):	TBS1 G05

No:	Parts(零部件):	Material Specification(用料标准):
✓ 01	COUNTER TOP 柜台面	16GA. THK. SUS 304 S/S
✓ 02	LEG 支腿	∅38mm 16 GA. THK. SUS 304 S/S TUBE
✓ 03	ADJUSTABLE FOOT INSERT 可调节嵌入式底脚	LUI CHUEN KEE (CHN)
✓ 04	REINFORCEMENT 加固件	16 GA. THK. SUS 304 S/S
05	SINK BOWL 洗碗槽	16 GA. THK. SUS 304 S/S
06	SINK WASTE 废料槽	
✓ 07	S.S. CROSS RAIL 横梁	∅32mm 16 GA. THK. SUS 304 S/S TUBE
08	WALL MOUNTED BRACKET 壁挂托架	16 GA. THK. SUS 304 S/S
09	UNDER SHELF 底架	18 GA. THK. SUS 304 S/S
10	MIXING FAUCET 混合龙头	
11	OVER SHELF 顶架	18 GA. THK. SUS 304 S/S
12	OUTER DOOR PANEL 外板	20 GA. THK. SUS 304 S/S
13	INNER DOOR PANEL 内板	22 GA. THK. SUS 304 S/S
14	CABINET BODY 柜身	20 GA. THK. SUS 304 S/S
15	CORNER BUMPER 拐角防护套	COLSON (CHN)
16	SWIVEL CASTOR 旋转角轮	GLOBE (CHN)
17	SOUND DEADEN MATERIAL 隔音材料	3mm THICKNESS
18	WALL FLASHING 防水面	20 GA. THK. SUS 304 S/S
19	CONDENSING UNIT 制冷机组	DANFOSS (CHN)
20	NOZZLE 排气口	∅25mm SUS 304 S/S TUBE

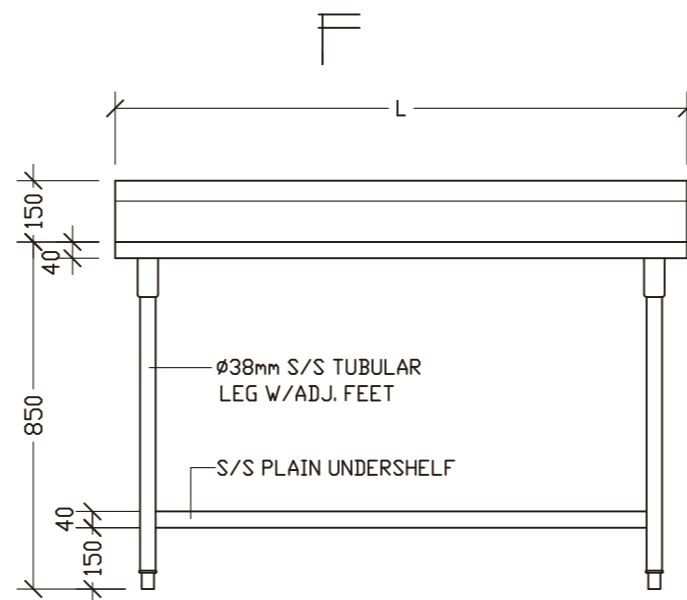

ELEVATION

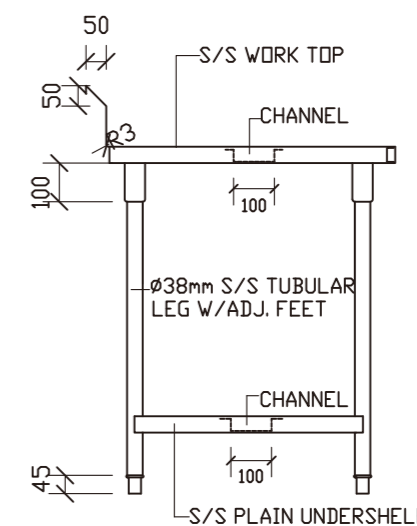

SECTION

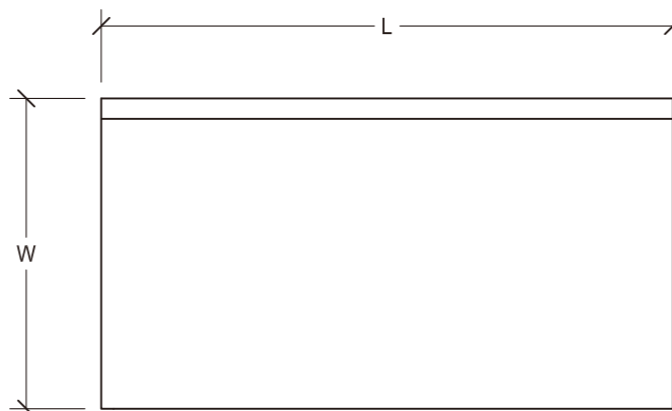

PLAN

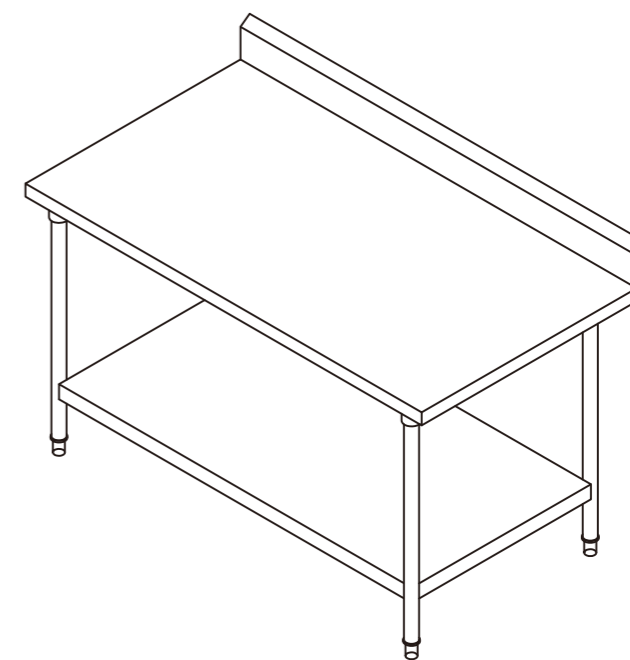

ISOMETRIC VIEW

No:	Item No(款号):	Qty(数量):	No:	Item No(款号):	Qty(数量):

Remark(备注):



SPOT WELDED A THREADED SHAFT TO THE UNDERSIDE OF WORK TOP / SHELF. THEN USE UNITS TO FIX WITH THE REINFORCEMENT / BRACKETS

技术说明:				SKU:			
1.所有产品边缘不能有毛刺, 覆膜面不能刮花;				名称:	建德C40+潜水俱乐部厨房		
2.公差要求标准: 符合GB/T G3280-2015不锈钢冷轧钢板和钢带标准中PT.A的公称宽度要求;				材料:			
3.所有标注尺寸为外尺寸;				编制:		日期:	
4.未注膜面方向朝外。				审核:		日期:	
A						视角:	☉
版本		批准	日期			版本:	A

STAINLESS STEEL SHOP DRAWING (CUSTOM)

不锈钢件生产要求图

Product Description (产品说明):	4-Tier Square Tube Storage Shelving
	四层通架
Model Type (模具型号):	JFG4 G06

No:	Parts(零部件):	Material Specification(用料标准):
01	COUNTER TOP 柜台面	16GA. THK. SUS 304 S/S
✓ 02	LEG 支腿	∅38mm 16 GA. THK. SUS 304 S/S TUBE
✓ 03	ADJUSTABLE FOOT INSERT 可调节嵌入式底脚	LUI CHUEN KEE (CHN)
04	REINFORCEMENT 加固件	16 GA. THK. SUS 304 S/S
05	SINK BOWL 洗碗槽	16 GA. THK. SUS 304 S/S
06	SINK WASTE 废料槽	
✓ 07	S.S. CROSS RAIL 横梁	∅32mm 16 GA. THK. SUS 304 S/S TUBE
08	WALL MOUNTED BRACKET 壁装托架	16 GA. THK. SUS 304 S/S
09	UNDER SHELF 底架	18 GA. THK. SUS 304 S/S
10	MIXING FAUCET 混合龙头	
11	OVER SHELF 顶架	18 GA. THK. SUS 304 S/S
12	OUTER DOOR PANEL 外板	20 GA. THK. SUS 304 S/S
13	INNER DOOR PANEL 内板	22 GA. THK. SUS 304 S/S
14	CABINET BODY 柜身	20 GA. THK. SUS 304 S/S
15	CORNER BUMPER 拐角防护套	COLSON (CHN)
16	SWIVEL CASTOR 旋转角轮	GLOBE (CHN)
17	SOUND DEADEN MATERIAL 隔音材料	3mm THICKNESS
18	WALL FLASHING 防水面	20 GA. THK. SUS 304 S/S
19	CONDENSING UNIT 制冷机组	DANFOSS (CHN)
20	NOZZLE 排气口	∅25mm SUS 304 S/S TUBE

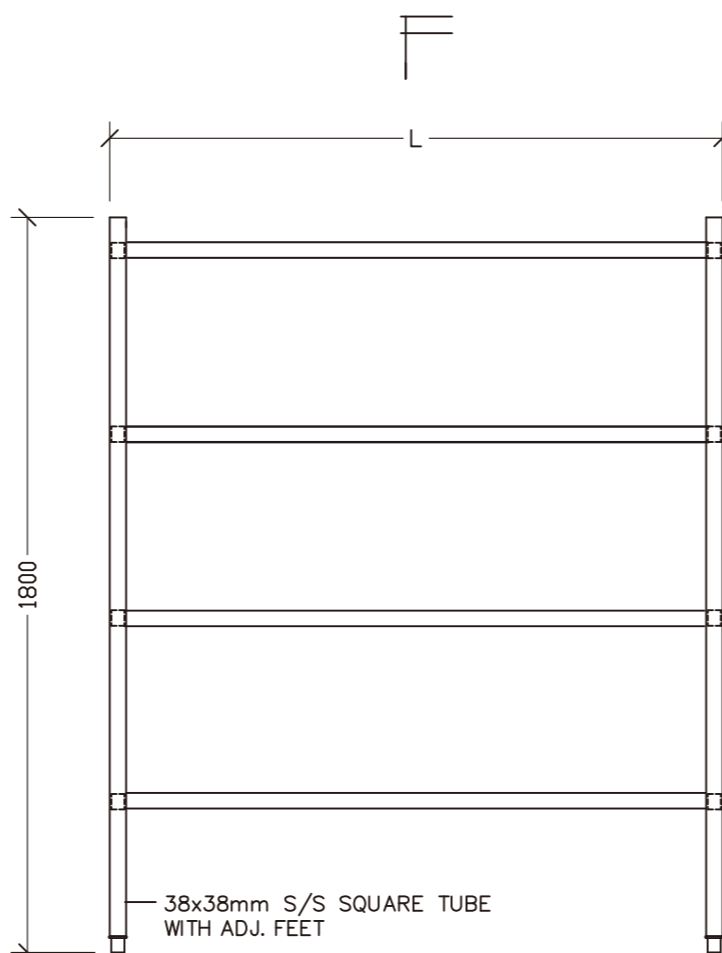

ELEVATION

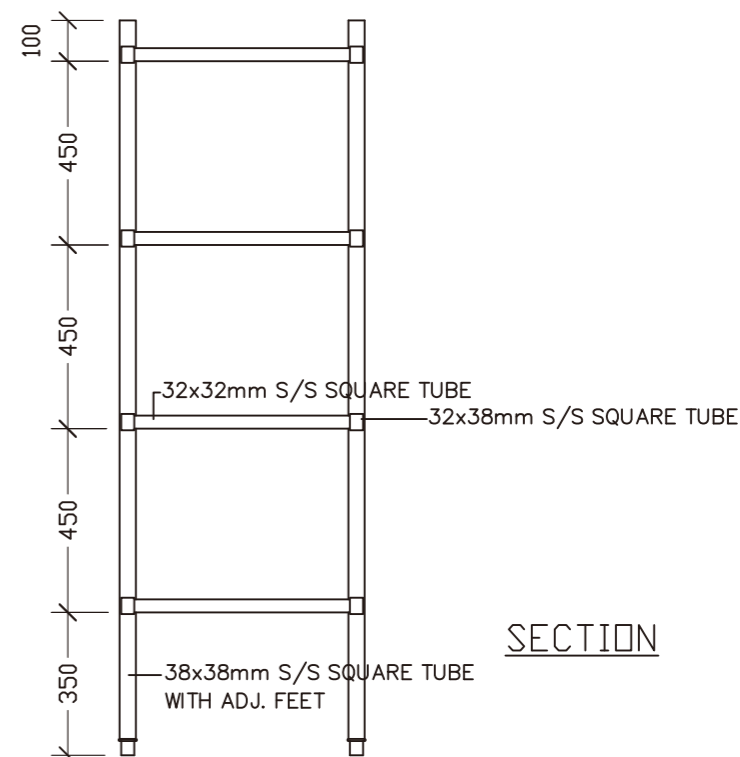

SECTION

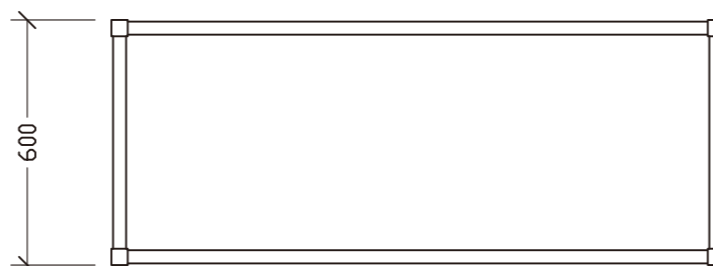

PLAN

No:	Item No(款号):	Qty(数量):	No:	Item No(款号):	Qty(数量):

Remark(备注):



M5

SPOT WELDED A THREADED SHAFT TO THE UNDERSIDE OF WORK TOP / SHELF. THEN USE UNITS TO FIX WITH THE REINFORCEMENT / BRACKETS

技术说明:				SKU:			
1.所有产品边缘不能有毛刺, 覆膜面不能刮花;				名称:	建德C40+潜水俱乐部厨房		
2.公差要求标准: 符合GB/T G3280-2015不锈钢冷轧钢板和钢带标准中PT.A的公称宽度要求;				材料:			
3.所有标注尺寸为外尺寸;				编制:		日期:	
4.未注膜面方向朝外。				审核:		日期:	
A						视角:	☉
版本		批准	日期			版本:	A

STAINLESS STEEL SHOP DRAWING (CUSTOM)

不锈钢件生产要求图

Product Description (产品说明):	Cabinet W/2 Drawers
	打荷台
Model Type (模具型号):	CCHD2 G07

No:	Parts(零部件):	Material Specification(用料标准):
✓ 01	COUNTER TOP 柜台面	16GA. THK. SUS 304 S/S
02	LEG 支腿	∅38mm 16 GA. THK. SUS 304 S/S TUBE
✓ 03	ADJUSTABLE FOOT INSERT 可调节嵌入式底脚	LUI CHUEN KEE (CHN)
✓ 04	REINFORCEMENT 加固件	16 GA. THK. SUS 304 S/S
05	SINK BOWL 洗碗槽	16 GA. THK. SUS 304 S/S
06	SINK WASTE 废料槽	
07	S.S. CROSS RAIL 横梁	∅32mm 16 GA. THK. SUS 304 S/S TUBE
08	WALL MOUNTED BRACKET 壁装托架	16 GA. THK. SUS 304 S/S
✓ 09	UNDER SHELF 底架	18 GA. THK. SUS 304 S/S
10	MIXING FAUCET 混合龙头	
11	OVER SHELF 顶架	18 GA. THK. SUS 304 S/S
✓ 12	OUTER DOOR PANEL 外板	20 GA. THK. SUS 304 S/S
✓ 13	INNER DOOR PANEL 内板	22 GA. THK. SUS 304 S/S
✓ 14	CABINET BODY 柜身	20 GA. THK. SUS 304 S/S
15	CORNER BUMPER 拐角防护套	COLSON (CHN)
16	SWIVEL CASTOR 旋转角轮	GLOBE (CHN)
17	SOUND DEADEN MATERIAL 隔音材料	3mm THICKNESS
18	WALL FLASHING 防水面	20 GA. THK. SUS 304 S/S
19	CONDENSING UNIT 制冷机组	DANFOSS (CHN)
20	NOZZLE 排气口	∅25mm SUS 304 S/S TUBE

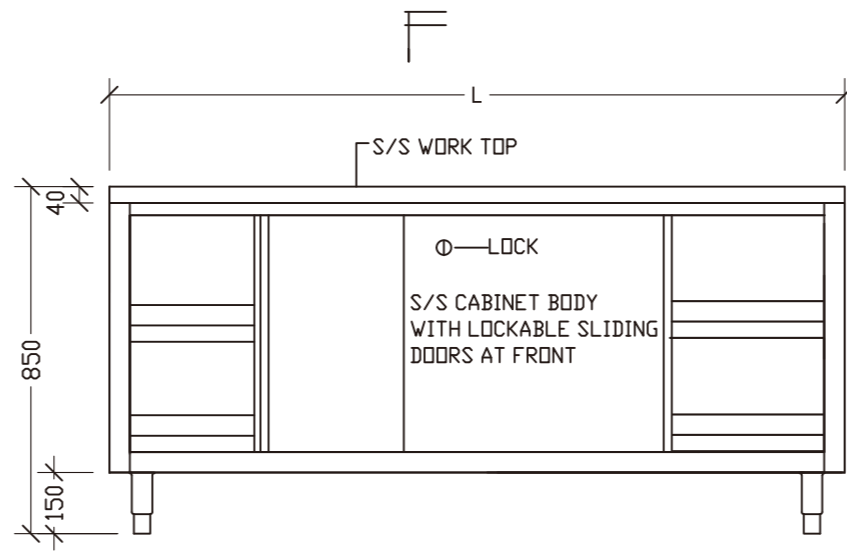

ELEVATION

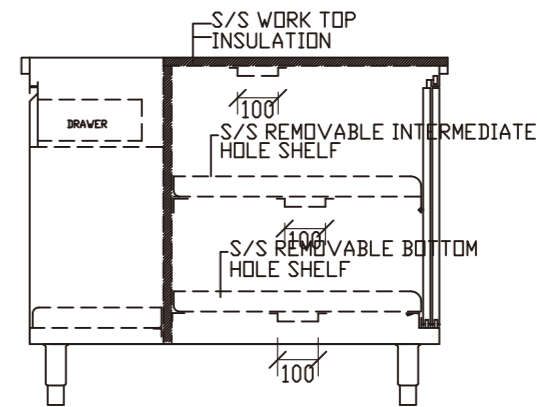

SECTION

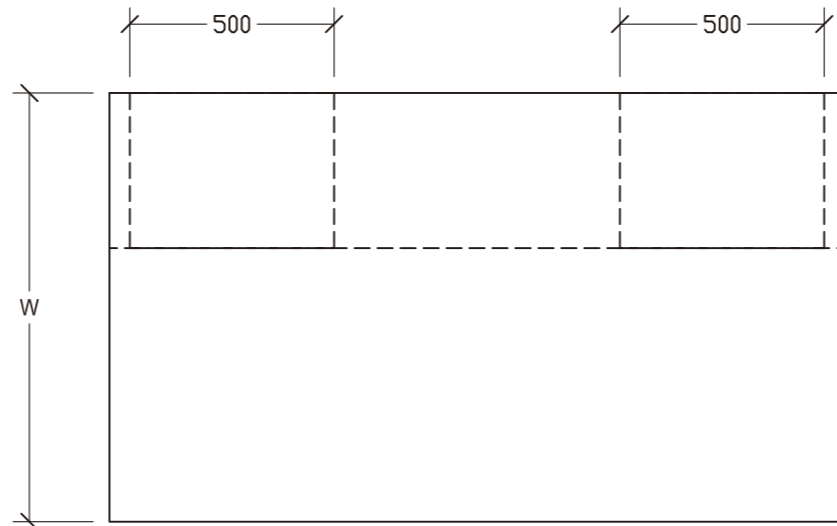

PLAN

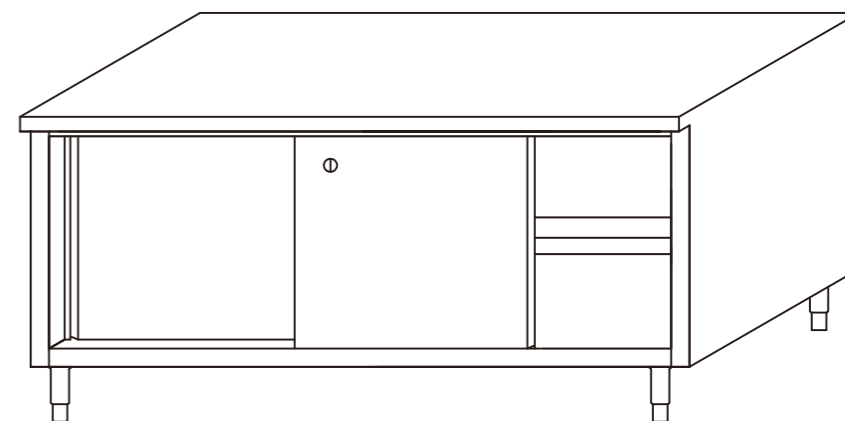

ISOMETRIC VIEW

No:	Item No(款号):	Qty(数量):	No:	Item No(款号):	Qty(数量):

Remark(备注):



SPOT WELDED A THREADED SHAFT TO THE UNDERSIDE OF WORK TOP / SHELF. THEN USE UNITS TO FIX WITH THE REINFORCEMENT / BRACKETS

技术说明:				SKU:			
1.所有产品边缘不能有毛刺, 覆膜面不能刮花;				名称:	建德C40+潜水俱乐部厨房		
2.公差要求标准: 符合GB/T G3280-2015不锈钢冷轧钢板和钢带标准中PT.A的公称宽度要求;				材料:			
3.所有标注尺寸为外尺寸;				编制:		日期:	
4.未注膜面方向朝外。				审核:		日期:	
A						视角:	☉ ☒
版本		批准	日期			版本:	A

STAINLESS STEEL SHOP DRAWING (CUSTOM)

不锈钢件生产要求图

Product Description (产品说明):	Work Table W/Under Shelf
	工作台下置层板
Model Type (模具型号):	TBS1 G08

No:	Parts(零部件):	Material Specification(用料标准):
✓ 01	COUNTER TOP 柜台面	16GA. THK. SUS 304 S/S
✓ 02	LEG 支腿	∅38mm 16 GA. THK. SUS 304 S/S TUBE
✓ 03	ADJUSTABLE FOOT INSERT 可调节嵌入式底脚	LUI CHUEN KEE (CHN)
✓ 04	REINFORCEMENT 加固件	16 GA. THK. SUS 304 S/S
05	SINK BOWL 洗碗槽	16 GA. THK. SUS 304 S/S
06	SINK WASTE 废料槽	
✓ 07	S.S. CROSS RAIL 横梁	∅32mm 16 GA. THK. SUS 304 S/S TUBE
08	WALL MOUNTED BRACKET 壁装托架	16 GA. THK. SUS 304 S/S
09	UNDER SHELF 底架	18 GA. THK. SUS 304 S/S
10	MIXING FAUCET 混合龙头	
11	OVER SHELF 顶架	18 GA. THK. SUS 304 S/S
12	OUTER DOOR PANEL 外板	20 GA. THK. SUS 304 S/S
13	INNER DOOR PANEL 内板	22 GA. THK. SUS 304 S/S
14	CABINET BODY 柜身	20 GA. THK. SUS 304 S/S
15	CORNER BUMPER 拐角防护套	COLSON (CHN)
16	SWIVEL CASTOR 旋转角轮	GLOBE (CHN)
17	SOUND DEADEN MATERIAL 隔音材料	3mm THICKNESS
18	WALL FLASHING 防水面	20 GA. THK. SUS 304 S/S
19	CONDENSING UNIT 制冷机组	DANFOSS (CHN)
20	NOZZLE 排气口	∅25mm SUS 304 S/S TUBE

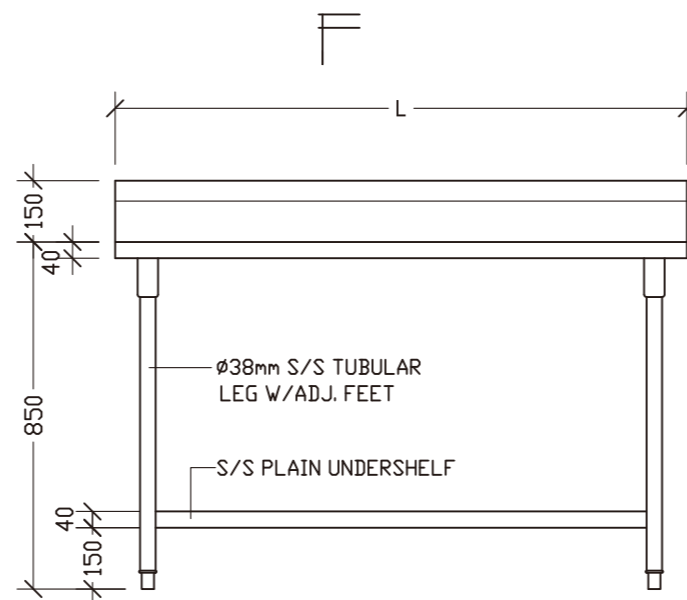

ELEVATION

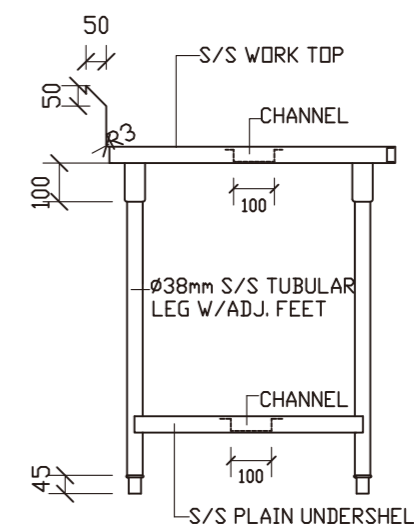

SECTION

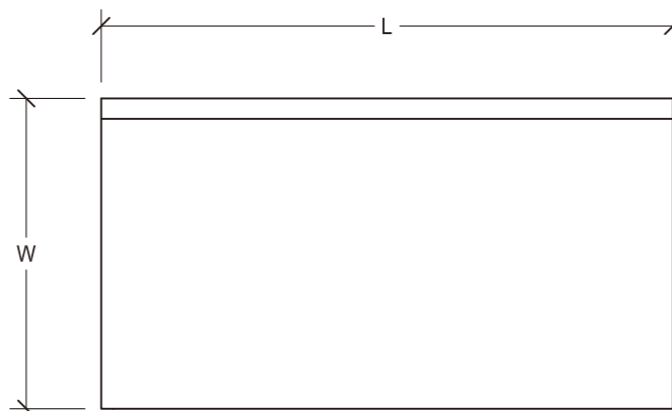

PLAN

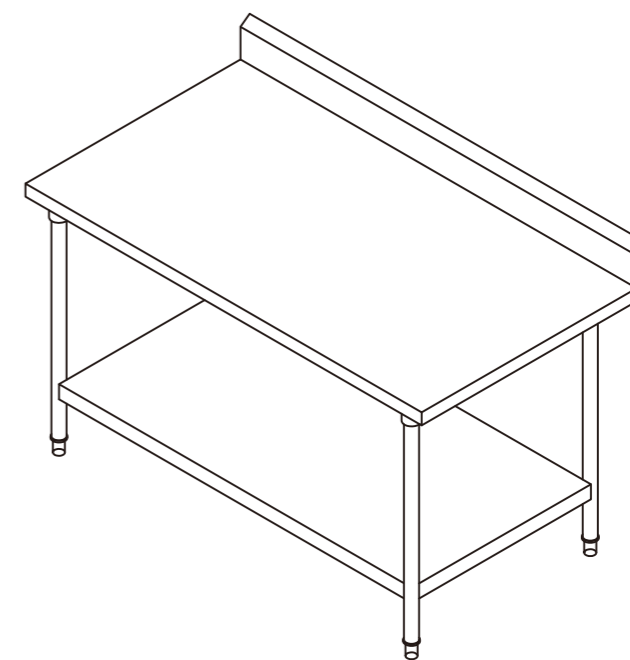

ISOMETRIC VIEW

No:	Item No(款号):	Qty(数量):	No:	Item No(款号):	Qty(数量):

Remark(备注):



SPOT WELDED A THREADED SHAFT TO THE UNDERSIDE OF WORK TOP / SHELF. THEN USE UNITS TO FIX WITH THE REINFORCEMENT / BRACKETS

技术说明:				SKU:			
1.所有产品边缘不能有毛刺, 覆膜面不能刮花;				名称:	建德C40+潜水俱乐部厨房		
2.公差要求标准: 符合GB/T G3280-2015不锈钢冷轧钢板和钢带标准中PT.A的公称宽度要求;				材料:			
3.所有标注尺寸为外尺寸;				编制:		日期:	
4.未注膜面方向朝外。				审核:		日期:	
A						视角:	☉
版本		批准	日期			版本:	A

STAINLESS STEEL SHOP DRAWING (CUSTOM)

不锈钢件生产要求图

Product Description (产品说明):	Work Table W/Twin Sinks
	工作台连双星盆 (中间去水)
Model Type (模具型号):	STSH1 G09

No:	Parts(零部件):	Material Specification(用料标准):
✓ 01	COUNTER TOP 柜台面	16GA. THK. SUS 304 S/S
✓ 02	LEG 支腿	∅38mm 16 GA. THK. SUS 304 S/S TUBE
✓ 03	ADJUSTABLE FOOT INSERT 可调节嵌入式底脚	LUI CHUEN KEE (CHN)
✓ 04	REINFORCEMENT 加固件	16 GA. THK. SUS 304 S/S
✓ 05	SINK BOWL 洗碗槽	16 GA. THK. SUS 304 S/S
06	SINK WASTE 废料槽	
✓ 07	S.S. CROSS RAIL 横梁	∅32mm 16 GA. THK. SUS 304 S/S TUBE
08	WALL MOUNTED BRACKET 壁装托架	16 GA. THK. SUS 304 S/S
09	UNDER SHELF 底架	18 GA. THK. SUS 304 S/S
✓ 10	MIXING FAUCET 混合龙头	
11	OVER SHELF 顶架	18 GA. THK. SUS 304 S/S
12	OUTER DOOR PANEL 外板	20 GA. THK. SUS 304 S/S
13	INNER DOOR PANEL 内板	22 GA. THK. SUS 304 S/S
14	CABINET BODY 柜身	20 GA. THK. SUS 304 S/S
15	CORNER BUMPER 拐角防护套	COLSON (CHN)
16	SWIVEL CASTOR 旋转角轮	GLOBE (CHN)
17	SOUND DEADEN MATERIAL 隔音材料	3mm THICKNESS
18	WALL FLASHING 防水面	20 GA. THK. SUS 304 S/S
19	CONDENSING UNIT 制冷机组	DANFOSS (CHN)
20	NOZZLE 排气口	∅25mm SUS 304 S/S TUBE

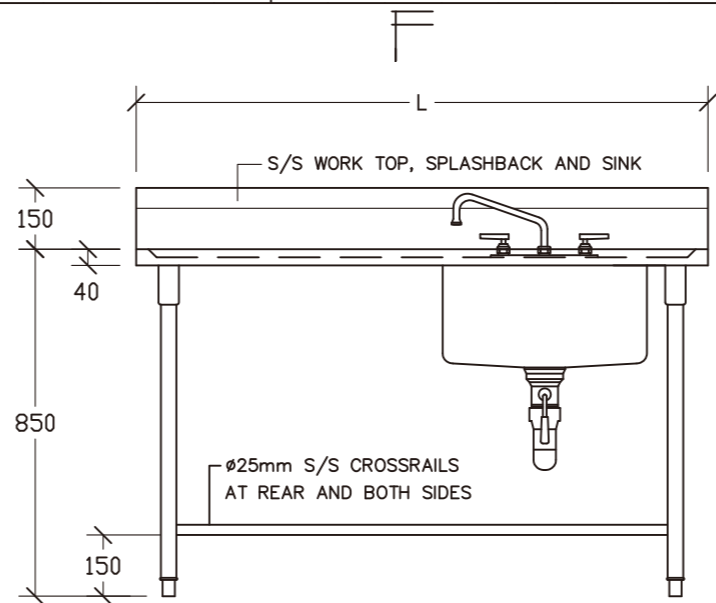

ELEVATION

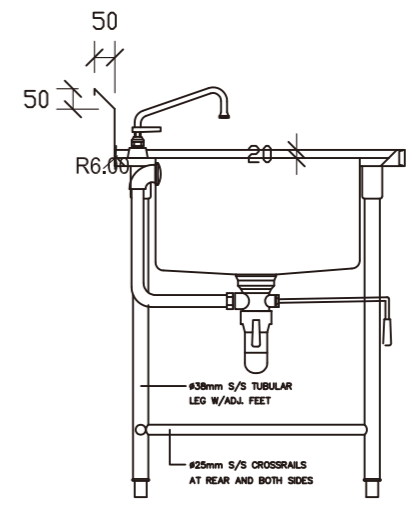

SECTION

No:	Item No(款号):	Qty(数量):	No:	Item No(款号):	Qty(数量):

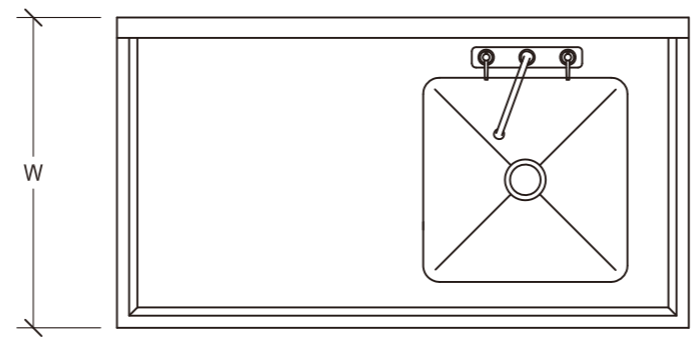

PLAN

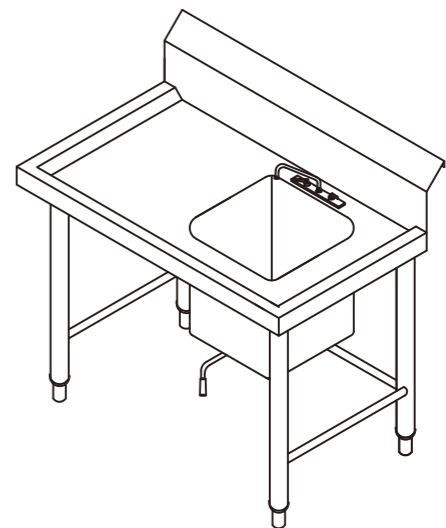

ISOMETRIC VIEW

Remark(备注):

 M5

SPOT WELDED A THREADED SHAFT TO THE UNDERSIDE OF WORK TOP / SHELF. THEN USE UNITS TO FIX WITH THE REINFORCEMENT / BRACKETS

技术说明:				SKU:			
1.所有产品边缘不能有毛刺, 覆膜面不能刮花;				名称:	建德C40+潜水俱乐部厨房		
2.公差要求标准: 符合GB/T G3280-2015不锈钢冷轧钢板和钢带标准中PT.A的公称宽度要求;				材料:			
3.所有标注尺寸为外尺寸;				编制:		日期:	
4.未注膜面方向朝外。				审核:		日期:	
A						视角:	
版本		批准	日期			版本:	A

STAINLESS STEEL SHOP DRAWING (CUSTOM)

不锈钢件生产要求图

Product Description (产品说明):	Work Table
	调料平台
Model Type (模具型号):	TB G11

No:	Parts(零部件):	Material Specification(用料标准):
✓ 01	COUNTER TOP 柜台面	16GA. THK. SUS 304 S/S
✓ 02	LEG 支腿	∅38mm 16 GA. THK. SUS 304 S/S TUBE
✓ 03	ADJUSTABLE FOOT INSERT 可调节嵌入式底脚	LUI CHUEN KEE (CHN)
✓ 04	REINFORCEMENT 加固件	16 GA. THK. SUS 304 S/S
05	SINK BOWL 洗碗槽	16 GA. THK. SUS 304 S/S
06	SINK WASTE 废料槽	
✓ 07	S.S. CROSS RAIL 横梁	∅32mm 16 GA. THK. SUS 304 S/S TUBE
08	WALL MOUNTED BRACKET 壁装托架	16 GA. THK. SUS 304 S/S
09	UNDER SHELF 底架	18 GA. THK. SUS 304 S/S
10	MIXING FAUCET 混合龙头	
11	OVER SHELF 顶架	18 GA. THK. SUS 304 S/S
12	OUTER DOOR PANEL 外板	20 GA. THK. SUS 304 S/S
13	INNER DOOR PANEL 内板	22 GA. THK. SUS 304 S/S
14	CABINET BODY 柜身	20 GA. THK. SUS 304 S/S
15	CORNER BUMPER 拐角防护套	COLSON (CHN)
16	SWIVEL CASTOR 旋转角轮	GLOBE (CHN)
17	SOUND DEADEN MATERIAL 隔音材料	3mm THICKNESS
18	WALL FLASHING 防水面	20 GA. THK. SUS 304 S/S
19	CONDENSING UNIT 制冷机组	DANFOSS (CHN)
20	NOZZLE 排气口	∅25mm SUS 304 S/S TUBE

No:	Item No(款号):	Qty(数量):	No:	Item No(款号):	Qty(数量):

Remark(备注):



SPOT WELDED A THREADED SHAFT TO THE UNDERSIDE OF WORK TOP / SHELF. THEN USE UNITS TO FIX WITH THE REINFORCEMENT / BRACKETS

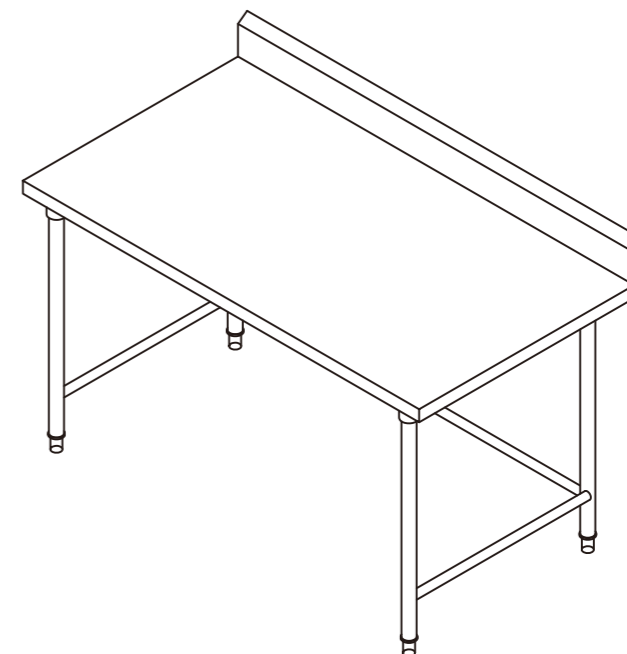
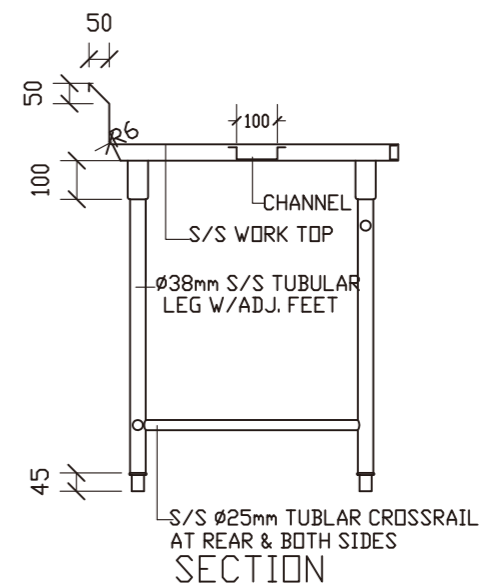
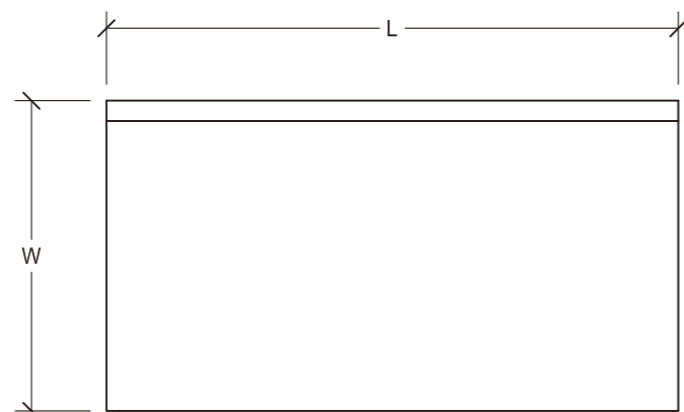
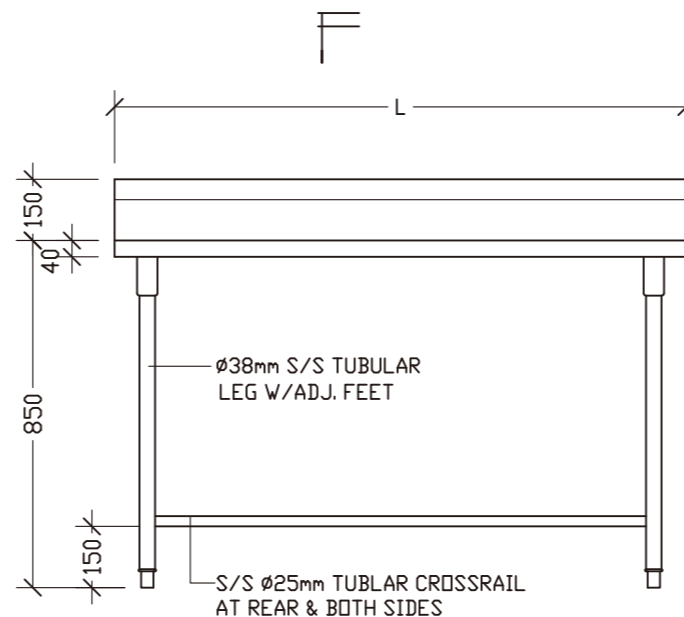

ISOMETRIC VIEW

技术说明:				SKU:			
1.所有产品边缘不能有毛刺, 覆膜面不能刮花;				名称:	建德C40+潜水俱乐部厨房		
2.公差要求标准: 符合GB/T G3280-2015不锈钢冷轧钢板和钢带标准中PT.A的公称宽度要求;				材料:			
3.所有标注尺寸为外尺寸;				编制:		日期:	
4.未注膜面方向朝外。				审核:		日期:	
A						视角:	☉
版本		批准	日期			版本:	A

STAINLESS STEEL SHOP DRAWING (CUSTOM)

不锈钢件生产要求图

Product Description (产品说明):	4-Tier Square Tube Storage Shelving
	四层通架
Model Type (模具型号):	JFG4 G17

No:	Parts(零部件):	Material Specification(用料标准):
01	COUNTER TOP 柜台面	16GA. THK. SUS 304 S/S
✓ 02	LEG 支腿	∅38mm 16 GA. THK. SUS 304 S/S TUBE
✓ 03	ADJUSTABLE FOOT INSERT 可调节嵌入式底脚	LUI CHUEN KEE (CHN)
04	REINFORCEMENT 加固件	16 GA. THK. SUS 304 S/S
05	SINK BOWL 洗碗槽	16 GA. THK. SUS 304 S/S
06	SINK WASTE 废料槽	
✓ 07	S.S. CROSS RAIL 横梁	∅32mm 16 GA. THK. SUS 304 S/S TUBE
08	WALL MOUNTED BRACKET 壁装托架	16 GA. THK. SUS 304 S/S
09	UNDER SHELF 底架	18 GA. THK. SUS 304 S/S
10	MIXING FAUCET 混合龙头	
11	OVER SHELF 顶架	18 GA. THK. SUS 304 S/S
12	OUTER DOOR PANEL 外板	20 GA. THK. SUS 304 S/S
13	INNER DOOR PANEL 内板	22 GA. THK. SUS 304 S/S
14	CABINET BODY 柜身	20 GA. THK. SUS 304 S/S
15	CORNER BUMPER 拐角防护套	COLSON (CHN)
16	SWIVEL CASTOR 旋转角轮	GLOBE (CHN)
17	SOUND DEADEN MATERIAL 隔音材料	3mm THICKNESS
18	WALL FLASHING 防水面	20 GA. THK. SUS 304 S/S
19	CONDENSING UNIT 制冷机组	DANFOSS (CHN)
20	NOZZLE 排气口	∅25mm SUS 304 S/S TUBE

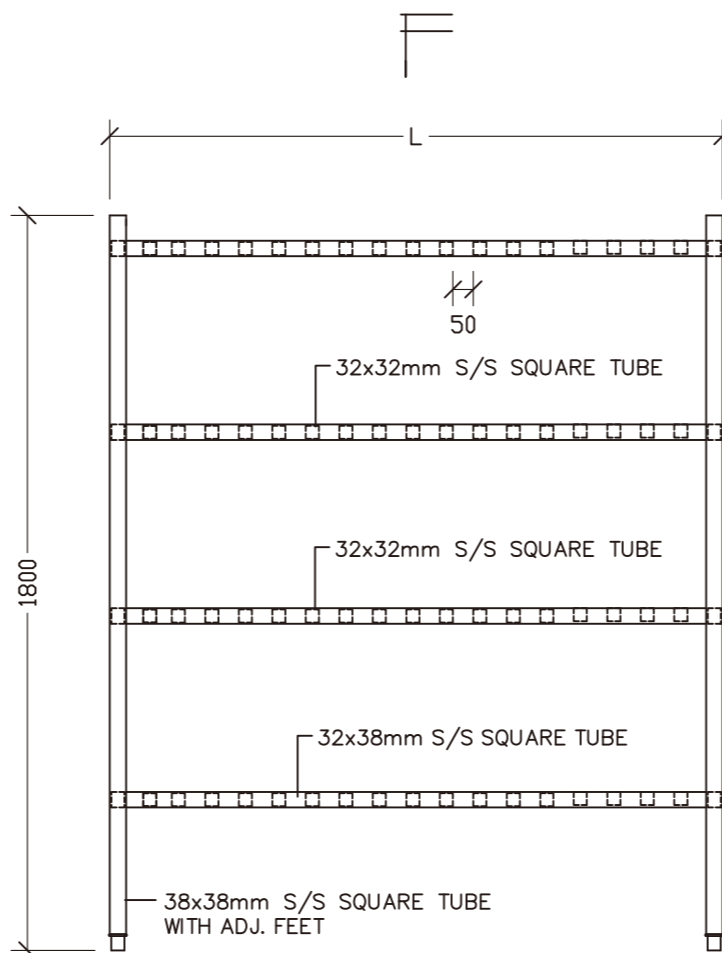

ELEVATION

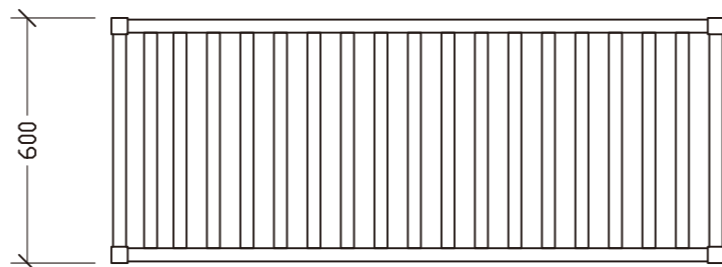

PLAN

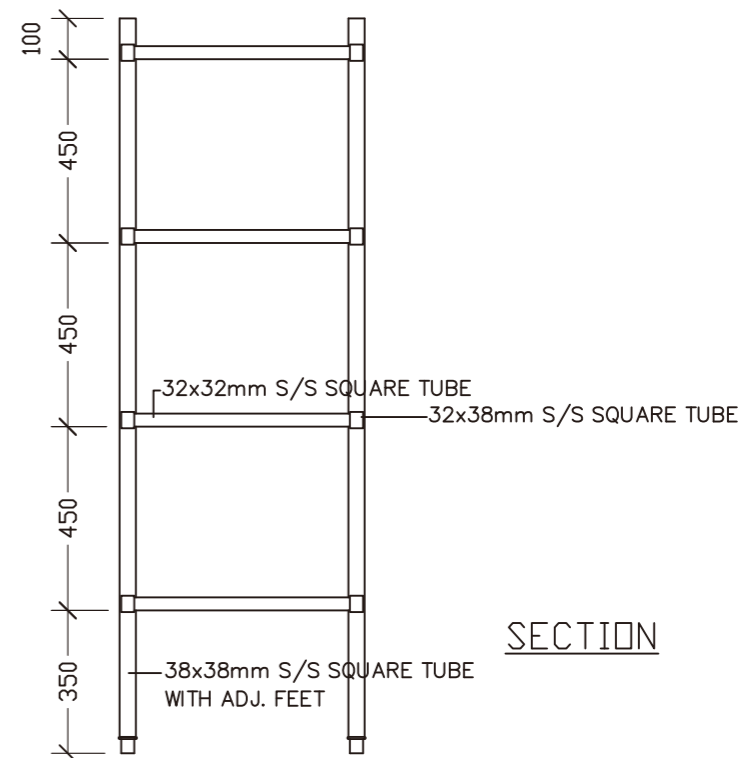

SECTION

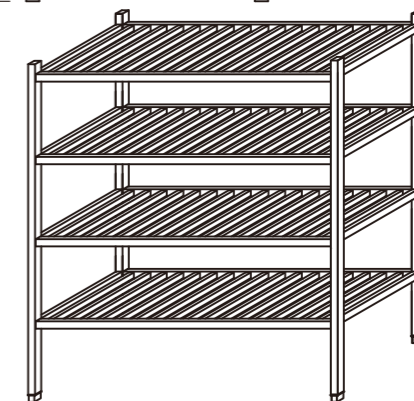

ISOMETRIC VIEW

No:	Item No(款号):	Qty(数量):	No:	Item No(款号):	Qty(数量):

Remark(备注):



M5

SPOT WELDED A THREADED SHAFT TO THE UNDERSIDE OF WORK TOP / SHELF. THEN USE UNITS TO FIX WITH THE REINFORCEMENT / BRACKETS

技术说明:
 1.所有产品边缘不能有毛刺, 覆膜面不能刮花;
 2.公差要求标准: 符合GB/T G3280-2015不锈钢冷轧钢板和钢带标准中PT.A的公称宽度要求;
 3.所有标注尺寸为外尺寸;
 4.未注膜面方向朝外。

SKU:
 名称: 建德C40+潜水俱乐部厨房
 材料:
 编制:
 审核:

日期:
 日期:
 视角:
 版本: A

A
 版本
 批准
 日期

STAINLESS STEEL SHOP DRAWING (CUSTOM)

不锈钢件生产要求图

Product Description (产品说明):	Hand Wash Sink
	挂墙洗手星盆
Model Type (模具型号):	SHSC1-W H01

No:	Parts(零部件):	Material Specfication(用料标准):
✓ 01	COUNTER TOP 柜台面	16GA. THK. SUS 304 S/S
02	LEG 支腿	∅38mm 16 GA. THK. SUS 304 S/S TUBE
03	ADJUSTABLE FOOT INSERT 可调节嵌入式底脚	LUI CHUEN KEE (CHN)
✓ 04	REINFORCEMENT 加固件	16 GA. THK. SUS 304 S/S
✓ 05	SINK BOWL 洗碗槽	16 GA. THK. SUS 304 S/S
06	SINK WASTE 废料槽	
07	S.S. CROSS RAIL 横梁	∅32mm 16 GA. THK. SUS 304 S/S TUBE
✓ 08	WALL MOUNTED BRACKET 壁装托架	16 GA. THK. SUS 304 S/S
09	UNDER SHELF 底架	18 GA. THK. SUS 304 S/S
✓ 10	MIXING FAUCET 混合龙头	
11	OVER SHELF 顶架	18 GA. THK. SUS 304 S/S
12	OUTER DOOR PANEL 外板	20 GA. THK. SUS 304 S/S
13	INNER DOOR PANEL 内板	22 GA. THK. SUS 304 S/S
14	CABINET BODY 柜身	20 GA. THK. SUS 304 S/S
15	CORNER BUMPER 拐角防护套	COLSON (CHN)
16	SWIVEL CASTOR 旋转角轮	GLOBE (CHN)
17	SOUND DEADEN MATERIAL 隔音材料	3mm THICKNESS
18	WALL FLASHING 防水面	20 GA. THK. SUS 304 S/S
19	CONDENSING UNIT 制冷机组	DANFOSS (CHN)
20	NOZZLE 排气口	∅25mm SUS 304 S/S TUBE

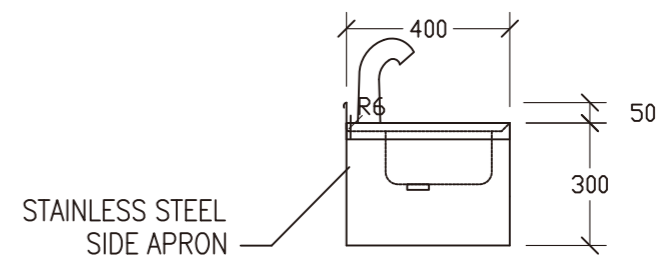
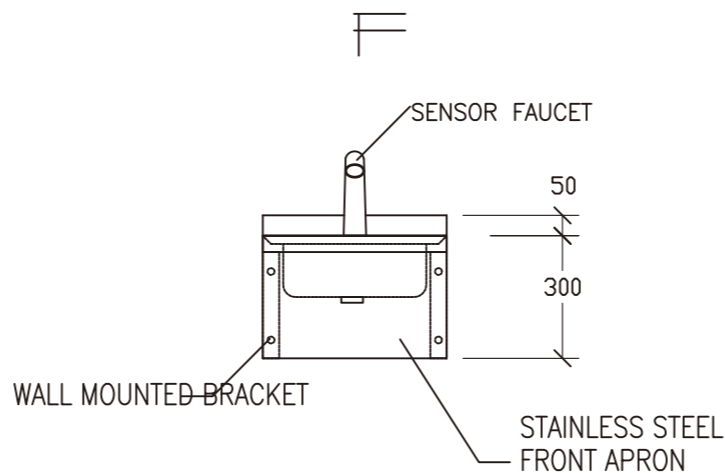

No:	Item No(款号):	Qty(数量):	No:	Item No(款号):	Qty(数量):

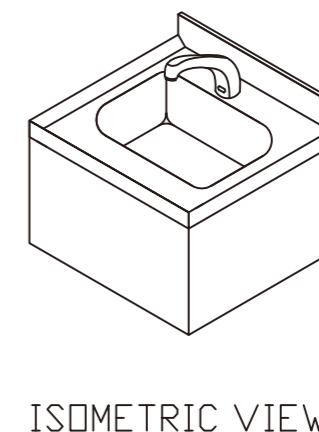
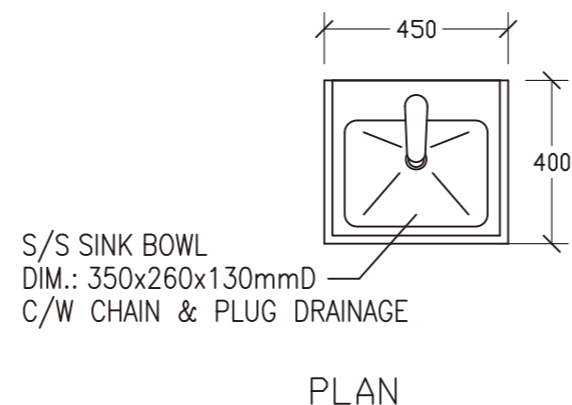

Remark(备注):

M5
SPOT WELDED A THREADED SHAFT TO THE UNDERSIDE OF WORK TOP / SHELF. THEN USE UNITS TO FIX WITH THE REINFORCEMENT / BRACKETS

				技术说明:	SKU:					
				1.所有产品边缘不能有毛刺, 覆膜面不能刮花;	名称:	建德C40+潜水俱乐部厨房				
				2.公差要求标准: 符合GB/T G3280-2015不锈钢冷轧钢板和钢带标准中PT.A的公称宽度要求;	材料:					
				3.所有标注尺寸为外尺寸;	编制:			日期:		
				4.未注膜面方向朝外。	审核:			日期:		
A								视角:	☉ ☒	
版本			批准	日期				版本:	A	

STAINLESS STEEL SHOP DRAWING (CUSTOM)

不锈钢件生产要求图

Product Description (产品说明):	ELE.RICE Warming Cart
	电热暖饭车
Model Type (模具型号):	MHR H03

No:	Parts(零部件):	Material Specification(用料标准):
✓ 01	COUNTER TOP 柜台面	16GA. THK. SUS 304 S/S
02	LEG 支腿	∅38mm 16 GA. THK. SUS 304 S/S TUBE
03	ADJUSTABLE FOOT INSERT 可调节嵌入式底脚	LUI CHUEN KEE (CHN)
✓ 04	REINFORCEMENT 加固件	16 GA. THK. SUS 304 S/S
✓ 05	SINK BOWL 洗碗槽	16 GA. THK. SUS 304 S/S
06	SINK WASTE 废料槽	
07	S.S. CROSS RAIL 横梁	∅32mm 16 GA. THK. SUS 304 S/S TUBE
08	WALL MOUNTED BRACKET 壁装托架	16 GA. THK. SUS 304 S/S
09	UNDER SHELF 底架	18 GA. THK. SUS 304 S/S
10	MIXING FAUCET 混合龙头	
11	OVER SHELF 顶架	18 GA. THK. SUS 304 S/S
✓ 12	OUTER DOOR PANEL 外板	20 GA. THK. SUS 304 S/S
✓ 13	INNER DOOR PANEL 内板	22 GA. THK. SUS 304 S/S
✓ 14	CABINET BODY 柜身	20 GA. THK. SUS 304 S/S
✓ 15	CORNER BUMPER 拐角防护套	COLSON (CHN)
✓ 16	SWIVEL CASTOR 旋转角轮	GLOBE (CHN)
17	SOUND DEADEN MATERIAL 隔音材料	3mm THICKNESS
18	WALL FLASHING 防水面	20 GA. THK. SUS 304 S/S
19	CONDENSING UNIT 制冷机组	DANFOSS (CHN)
20	NOZZLE 排气口	∅25mm SUS 304 S/S TUBE

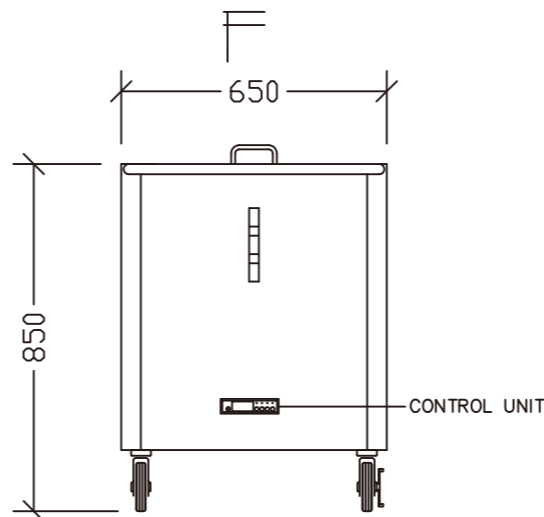

ELEVATION

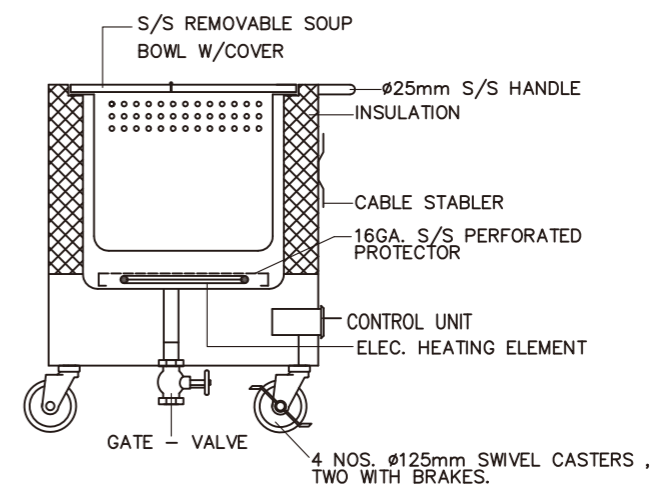

SECTION

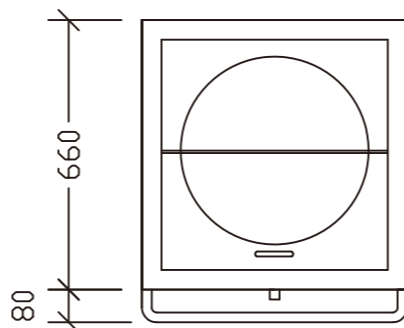

PLAN

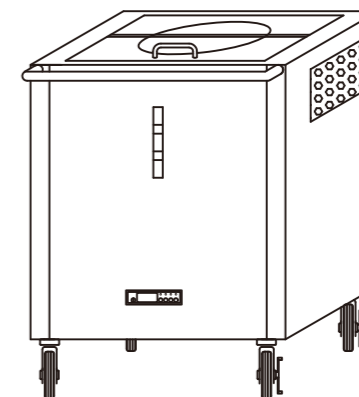

ISOMETRIC VIEW

No:	Item No(款号):	Qty(数量):	No:	Item No(款号):	Qty(数量):

Remark(备注):



SPOT WELDED A THREADED SHAFT TO THE UNDERSIDE OF WORK TOP / SHELF. THEN USE UNITS TO FIX WITH THE REINFORCEMENT / BRACKETS

技术说明:				SKU:			
1.所有产品边缘不能有毛刺, 覆膜面不能刮花;				名称:	建德C40+潜水俱乐部厨房		
2.公差要求标准: 符合GB/T G3280-2015不锈钢冷轧钢板和钢带标准中PT.A的公称宽度要求;				材料:			
3.所有标注尺寸为外尺寸;				编制:		日期:	
4.未注膜面方向朝外。				审核:		日期:	
A						视角:	☉ ☒
版本		批准	日期			版本:	A

STAINLESS STEEL SHOP DRAWING (CUSTOM)

不锈钢件生产要求图

Product Description (产品说明):	Work Cabinet
	工作掩门柜
Model Type (模具型号):	CBH H04

No:	Parts(零部件):	Material Specification(用料标准):
✓ 01	COUNTER TOP 柜台面	16GA. THK. SUS 304 S/S
02	LEG 支腿	Ø38mm 16 GA. THK. SUS 304 S/S TUBE
✓ 03	ADJUSTABLE FOOT INSERT 可调节嵌入式底脚	LUI CHUEN KEE (CHN)
✓ 04	REINFORCEMENT 加固件	16 GA. THK. SUS 304 S/S
05	SINK BOWL 洗碗槽	16 GA. THK. SUS 304 S/S
06	SINK WASTE 废料槽	
07	S.S. CROSS RAIL 横梁	Ø32mm 16 GA. THK. SUS 304 S/S TUBE
08	WALL MOUNTED BRACKET 壁装托架	16 GA. THK. SUS 304 S/S
✓ 09	UNDER SHELF 底架	18 GA. THK. SUS 304 S/S
10	MIXING FAUCET 混合龙头	
11	OVER SHELF 顶架	18 GA. THK. SUS 304 S/S
✓ 12	OUTER DOOR PANEL 外板	20 GA. THK. SUS 304 S/S
✓ 13	INNER DOOR PANEL 内板	22 GA. THK. SUS 304 S/S
✓ 14	CABINET BODY 柜身	20 GA. THK. SUS 304 S/S
15	CORNER BUMPER 拐角防护套	COLSON (CHN)
16	SWIVEL CASTOR 旋转角轮	GLOBE (CHN)
17	SOUND DEADEN MATERIAL 隔音材料	3mm THICKNESS
18	WALL FLASHING 防水面	20 GA. THK. SUS 304 S/S
19	CONDENSING UNIT 制冷机组	DANFOSS (CHN)
20	NOZZLE 排气口	Ø25mm SUS 304 S/S TUBE

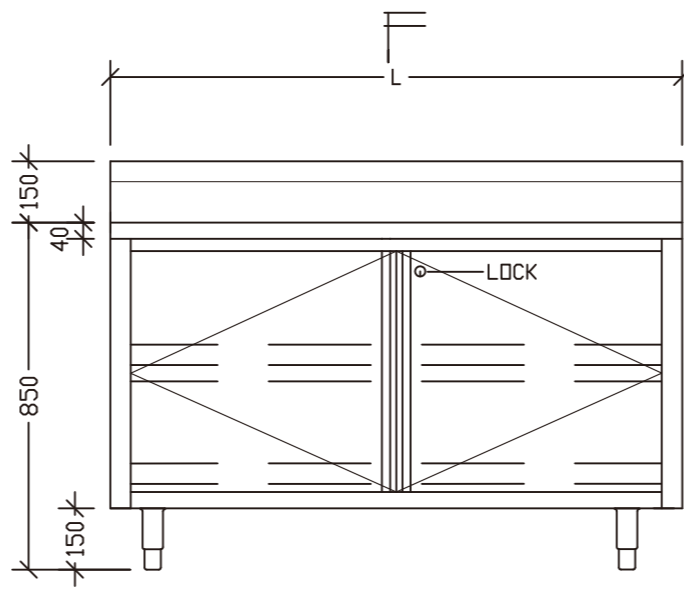

ELEVATION

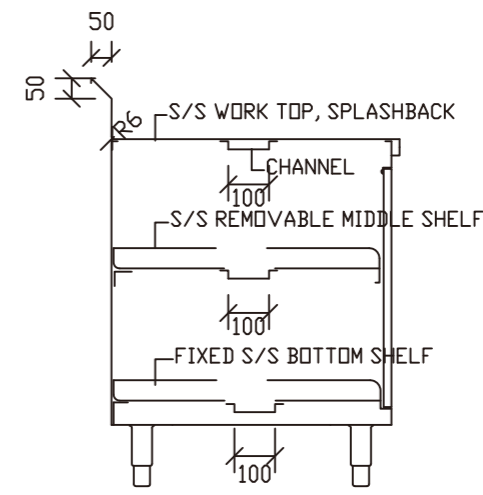

SECTION

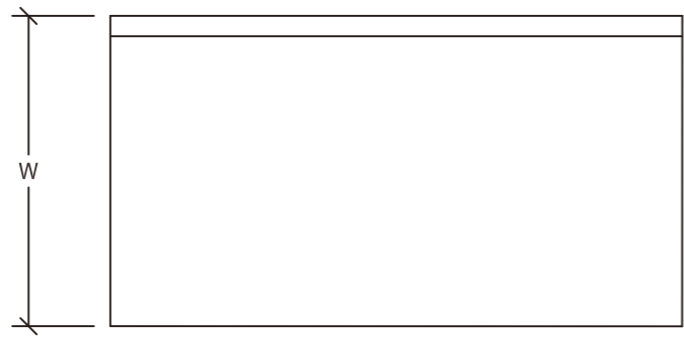

PLAN

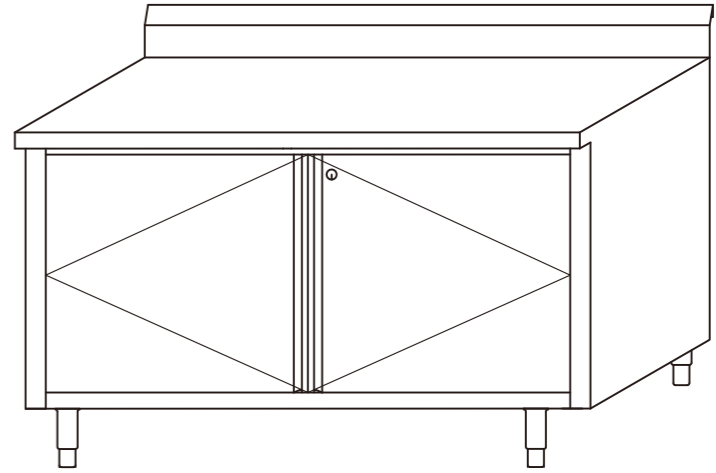

ISOMETRIC VIEW

No:	Item No(款号):	Qty(数量):	No:	Item No(款号):	Qty(数量):

Remark(备注):



SPOT WELDED A THREADED SHAFT TO THE UNDERSIDE OF WORK TOP / SHELF. THEN USE UNITS TO FIX WITH THE REINFORCEMENT / BRACKETS

技术说明:
 1.所有产品边缘不能有毛刺, 覆膜面不能刮花;
 2.公差要求标准: 符合GB/T G3280-2015不锈钢冷轧钢板和钢带标准中PT.A的公称宽度要求;
 3.所有标注尺寸为外尺寸;
 4.未注膜面方向朝外。

SKU:		日期:		视角:	☉
名称:	建德C40+潜水俱乐部厨房	日期:		版本:	A
材料:					
编制:					
审核:					

A					
版本			批准	日期	

STAINLESS STEEL SHOP DRAWING (CUSTOM)

不锈钢件生产要求图

Product Description (产品说明):	Bain Marie Cabinet
	热汤池柜
Model Type (模具型号):	CBM H05

No:	Parts(零部件):	Material Specfication(用料标准):
✓ 01	COUNTER TOP 柜台面	16GA. THK. SUS 304 S/S
02	LEG 支腿	∅38mm 16 GA. THK. SUS 304 S/S TUBE
✓ 03	ADJUSTABLE FOOT INSERT 可调节嵌入式底脚	LUI CHUEN KEE (CHN)
✓ 04	REINFORCEMENT 加固件	16 GA. THK. SUS 304 S/S
✓ 05	SINK BOWL 洗碗槽	16 GA. THK. SUS 304 S/S
06	SINK WASTE 废料槽	
07	S.S. CROSS RAIL 横梁	∅32mm 16 GA. THK. SUS 304 S/S TUBE
08	WALL MOUNTED BRACKET 壁装托架	16 GA. THK. SUS 304 S/S
✓ 09	UNDER SHELF 底架	18 GA. THK. SUS 304 S/S
10	MIXING FAUCET 混合龙头	
11	OVER SHELF 顶架	18 GA. THK. SUS 304 S/S
✓ 12	OUTER DOOR PANEL 外板	20 GA. THK. SUS 304 S/S
✓ 13	INNER DOOR PANEL 内板	22 GA. THK. SUS 304 S/S
✓ 14	CABINET BODY 柜身	20 GA. THK. SUS 304 S/S
15	CORNER BUMPER 拐角防护套	COLSON (CHN)
16	SWIVEL CASTOR 旋转角轮	GLOBE (CHN)
17	SOUND DEADEN MATERIAL 隔音材料	3mm THICKNESS
18	WALL FLASHING 防水面	20 GA. THK. SUS 304 S/S
19	CONDENSING UNIT 制冷机组	DANFOSS (CHN)
20	NOZZLE 排气口	∅25mm SUS 304 S/S TUBE

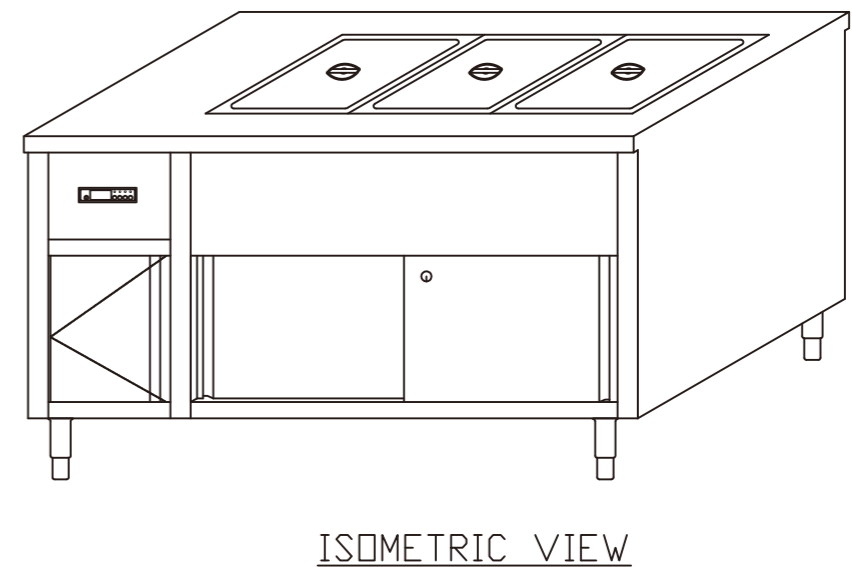
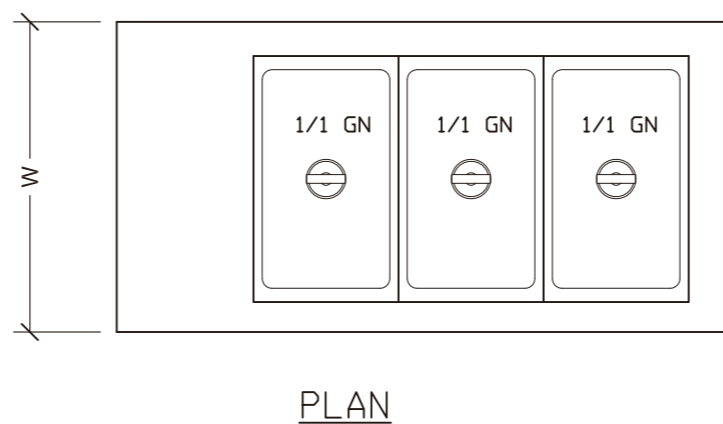
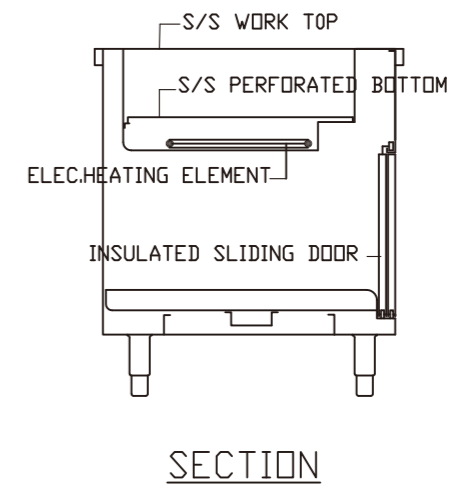
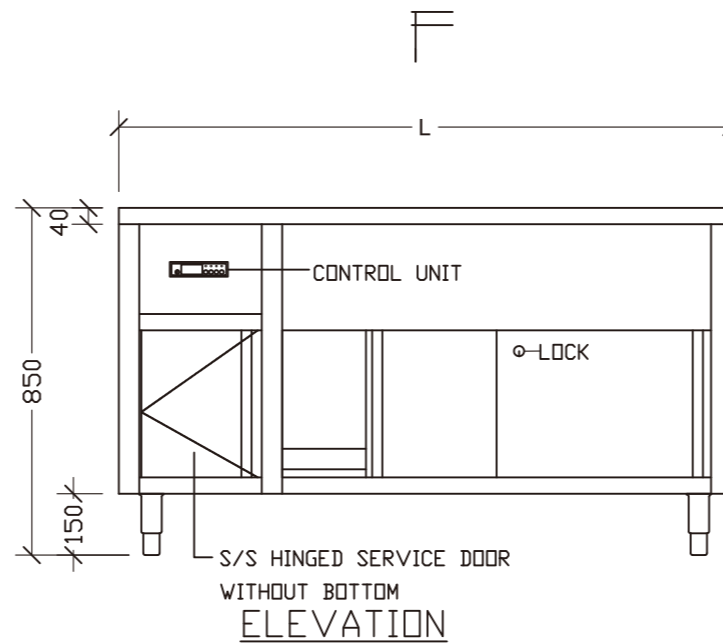

No:	Item No(款号):	Qty(数量):	No:	Item No(款号):	Qty(数量):

Remark(备注):

 M5

SPOT WELDED A THREADED SHAFT TO THE UNDERSIDE OF WORK TOP / SHELF. THEN USE UNITS TO FIX WITH THE REINFORCEMENT / BRACKETS

				技术说明:	SKU:			
				1.所有产品边缘不能有毛刺, 覆膜面不能刮花;	名称:	建德C40+潜水俱乐部厨房		
				2.公差要求标准: 符合GB/T G3280-2015不锈钢冷轧钢板和钢带标准中PT.A的公称宽度要求;	材料:			
				3.所有标注尺寸为外尺寸;	编制:		日期:	
				4.未注膜面方向朝外。	审核:		日期:	
A							视角:	
版本			批准	日期			版本:	A

STAINLESS STEEL SHOP DRAWING (CUSTOM)

不锈钢件生产要求图

Product Description (产品说明):	Work Cabinet
	工作掩门柜
Model Type (模具型号):	CBH H06

No:	Parts(零部件):	Material Specification(用料标准):
✓ 01	COUNTER TOP 柜台面	16GA. THK. SUS 304 S/S
02	LEG 支腿	Ø38mm 16 GA. THK. SUS 304 S/S TUBE
✓ 03	ADJUSTABLE FOOT INSERT 可调节嵌入式底脚	LUI CHUEN KEE (CHN)
✓ 04	REINFORCEMENT 加固件	16 GA. THK. SUS 304 S/S
05	SINK BOWL 洗碗槽	16 GA. THK. SUS 304 S/S
06	SINK WASTE 废料槽	
07	S.S. CROSS RAIL 横梁	Ø32mm 16 GA. THK. SUS 304 S/S TUBE
08	WALL MOUNTED BRACKET 壁装托架	16 GA. THK. SUS 304 S/S
✓ 09	UNDER SHELF 底架	18 GA. THK. SUS 304 S/S
10	MIXING FAUCET 混合龙头	
11	OVER SHELF 顶架	18 GA. THK. SUS 304 S/S
✓ 12	OUTER DOOR PANEL 外板	20 GA. THK. SUS 304 S/S
✓ 13	INNER DOOR PANEL 内板	22 GA. THK. SUS 304 S/S
✓ 14	CABINET BODY 柜身	20 GA. THK. SUS 304 S/S
15	CORNER BUMPER 拐角防护套	COLSON (CHN)
16	SWIVEL CASTOR 旋转角轮	GLOBE (CHN)
17	SOUND DEADEN MATERIAL 隔音材料	3mm THICKNESS
18	WALL FLASHING 防水面	20 GA. THK. SUS 304 S/S
19	CONDENSING UNIT 制冷机组	DANFOSS (CHN)
20	NOZZLE 排气口	Ø25mm SUS 304 S/S TUBE

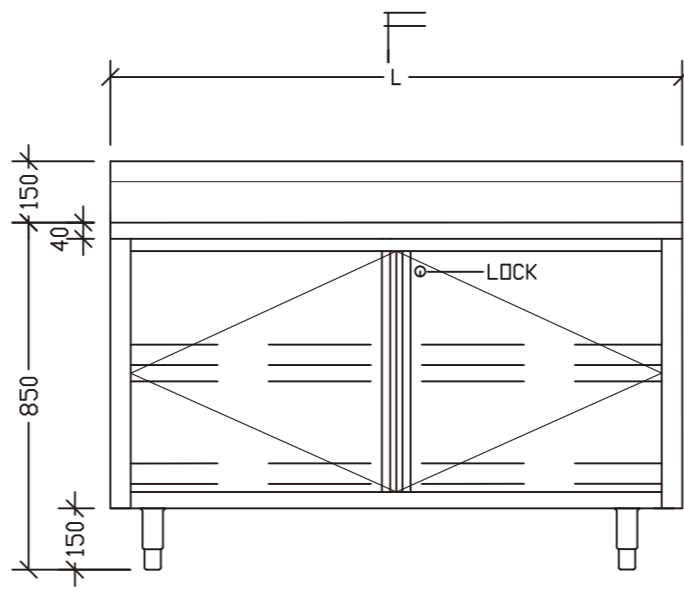

ELEVATION

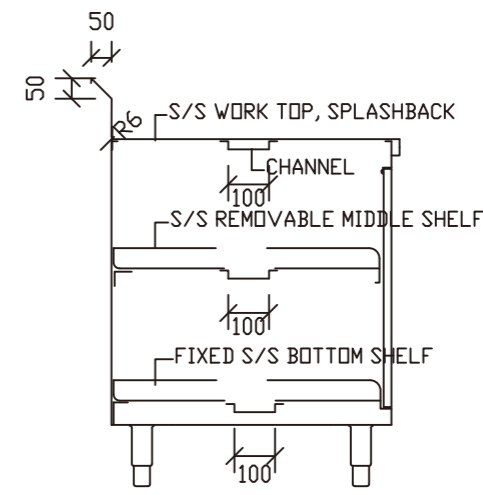

SECTION

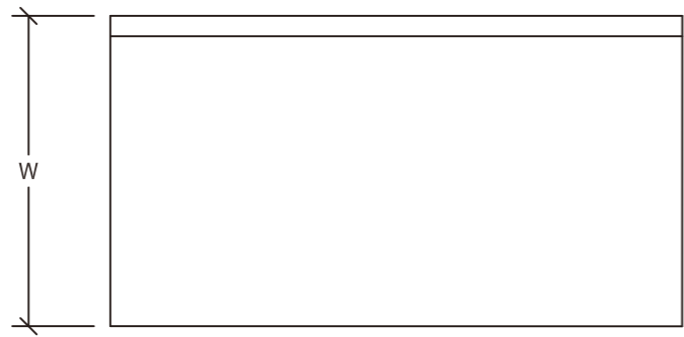

PLAN

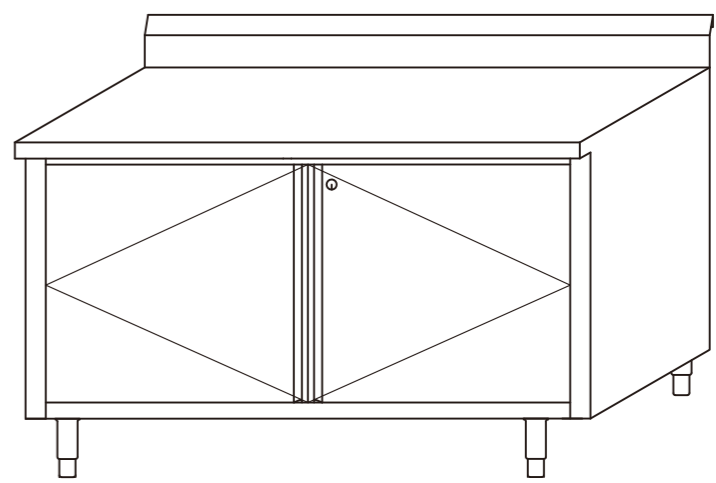

ISOMETRIC VIEW

No:	Item No(款号):	Qty(数量):	No:	Item No(款号):	Qty(数量):

Remark(备注):



SPOT WELDED A THREADED SHAFT TO THE UNDERSIDE OF WORK TOP / SHELF. THEN USE UNITS TO FIX WITH THE REINFORCEMENT / BRACKETS

技术说明:				SKU:			
1.所有产品边缘不能有毛刺, 覆膜面不能刮花;				名称:	建德C40+潜水俱乐部厨房		
2.公差要求标准: 符合GB/T G3280-2015不锈钢冷轧钢板和钢带标准中PT.A的公称宽度要求;				材料:			
3.所有标注尺寸为外尺寸;				编制:		日期:	
4.未注膜面方向朝外。				审核:		日期:	
A						视角:	☉ ☒
版本			批准	日期		版本:	A

STAINLESS STEEL SHOP DRAWING (CUSTOM)

不锈钢件生产要求图

Product Description (产品说明):	Work Counter W/Sink
	工作台连星盆 (中间去水)
Model Type (模具型号):	SBSH1 H08

No:	Parts(零部件):	Material Specification(用料标准):
✓ 01	COUNTER TOP 柜台面	16GA. THK. SUS 304 S/S
02	LEG 支腿	Ø38mm 16 GA. THK. SUS 304 S/S TUBE
✓ 03	ADJUSTABLE FOOT INSERT 可调节嵌入式底脚	LUI CHUEN KEE (CHN)
✓ 04	REINFORCEMENT 加固件	16 GA. THK. SUS 304 S/S
✓ 05	SINK BOWL 洗碗槽	16 GA. THK. SUS 304 S/S
06	SINK WASTE 废料槽	
07	S.S. CROSS RAIL 横梁	Ø32mm 16 GA. THK. SUS 304 S/S TUBE
08	WALL MOUNTED BRACKET 壁装托架	16 GA. THK. SUS 304 S/S
09	UNDER SHELF 底架	18 GA. THK. SUS 304 S/S
✓ 10	MIXING FAUCET 混合龙头	
11	OVER SHELF 顶架	18 GA. THK. SUS 304 S/S
✓ 12	OUTER DOOR PANEL 外板	20 GA. THK. SUS 304 S/S
✓ 13	INNER DOOR PANEL 内板	22 GA. THK. SUS 304 S/S
✓ 14	CABINET BODY 柜身	20 GA. THK. SUS 304 S/S
15	CORNER BUMPER 拐角防护套	COLSON (CHN)
16	SWIVEL CASTOR 旋转角轮	GLOBE (CHN)
17	SOUND DEADEN MATERIAL 隔音材料	3mm THICKNESS
18	WALL FLASHING 防水面	20 GA. THK. SUS 304 S/S
19	CONDENSING UNIT 制冷机组	DANFOSS (CHN)
20	NOZZLE 排气口	Ø25mm SUS 304 S/S TUBE

No:	Item No(款号):	Qty(数量):	No:	Item No(款号):	Qty(数量):
	CHO-015	1			

Remark(备注):



SPOT WELDED A THREADED SHAFT TO THE UNDERSIDE OF WORK TOP / SHELF. THEN USE UNITS TO FIX WITH THE REINFORCEMENT / BRACKETS

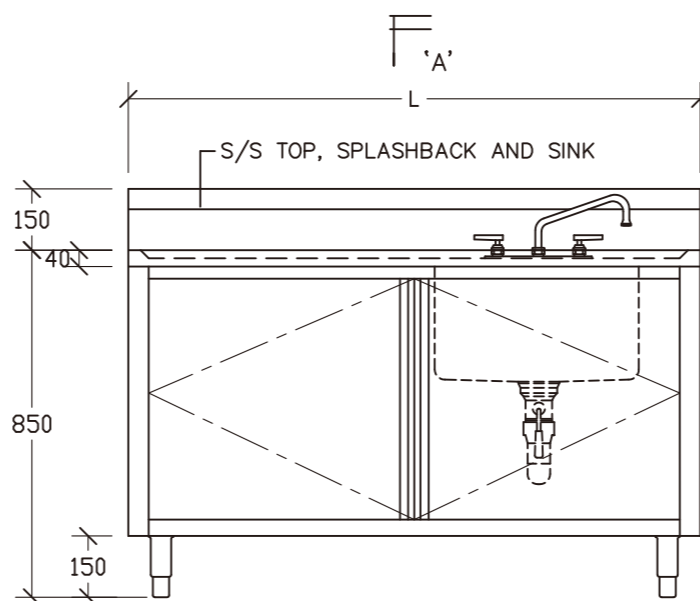

ELEVATION

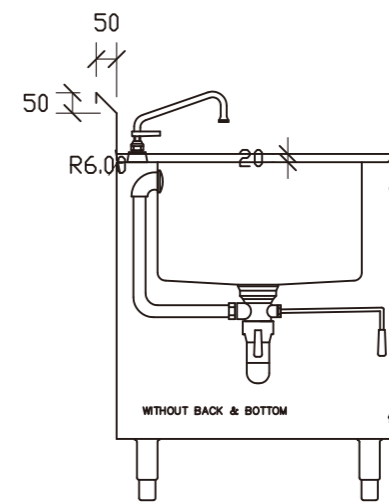

SECTION

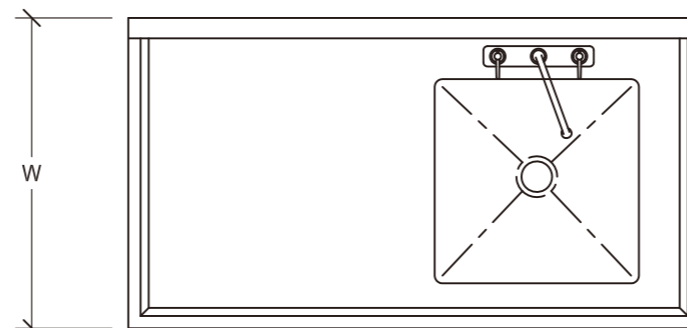

PLAN

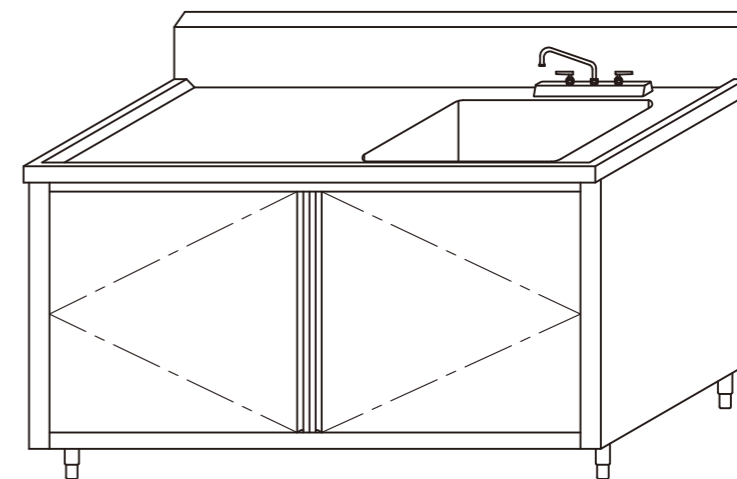

ISOMETRIC VIEW

					技术说明:	SKU:			
					1.所有产品边缘不能有毛刺, 覆膜面不能刮花;	名称:	建德C40+潜水俱乐部厨房		
					2.公差要求标准: 符合GB/T G3280-2015不锈钢冷轧钢板和钢带标准中PT.A的公称宽度要求;	材料:			
					3.所有标注尺寸为外尺寸;	编制:		日期:	视角:
A					4.未注膜面方向朝外。	审核:		日期:	版本: A
版本				批准	日期				

STAINLESS STEEL SHOP DRAWING (CUSTOM)

不锈钢件生产要求图

Product Description (产品说明):	Work Cabinet
	工作掩门柜
Model Type (模具型号):	CBH H09

No:	Parts(零部件):	Material Specification(用料标准):
✓ 01	COUNTER TOP 柜台面	16GA. THK. SUS 304 S/S
02	LEG 支腿	Ø38mm 16 GA. THK. SUS 304 S/S TUBE
✓ 03	ADJUSTABLE FOOT INSERT 可调节嵌入式底脚	LUI CHUEN KEE (CHN)
✓ 04	REINFORCEMENT 加固件	16 GA. THK. SUS 304 S/S
05	SINK BOWL 洗碗槽	16 GA. THK. SUS 304 S/S
06	SINK WASTE 废料槽	
07	S.S. CROSS RAIL 横梁	Ø32mm 16 GA. THK. SUS 304 S/S TUBE
08	WALL MOUNTED BRACKET 壁装托架	16 GA. THK. SUS 304 S/S
✓ 09	UNDER SHELF 底架	18 GA. THK. SUS 304 S/S
10	MIXING FAUCET 混合龙头	
11	OVER SHELF 顶架	18 GA. THK. SUS 304 S/S
✓ 12	OUTER DOOR PANEL 外板	20 GA. THK. SUS 304 S/S
✓ 13	INNER DOOR PANEL 内板	22 GA. THK. SUS 304 S/S
✓ 14	CABINET BODY 柜身	20 GA. THK. SUS 304 S/S
15	CORNER BUMPER 拐角防护套	COLSON (CHN)
16	SWIVEL CASTOR 旋转角轮	GLOBE (CHN)
17	SOUND DEADEN MATERIAL 隔音材料	3mm THICKNESS
18	WALL FLASHING 防水面	20 GA. THK. SUS 304 S/S
19	CONDENSING UNIT 制冷机组	DANFOSS (CHN)
20	NOZZLE 排气口	Ø25mm SUS 304 S/S TUBE

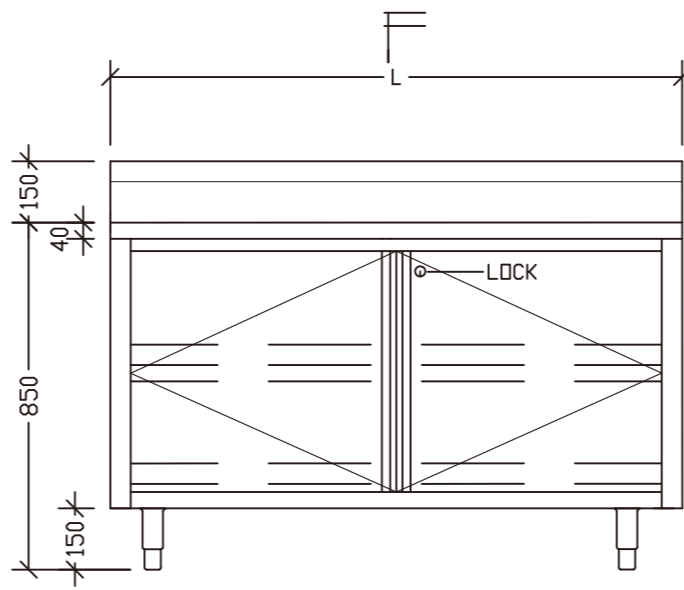

ELEVATION

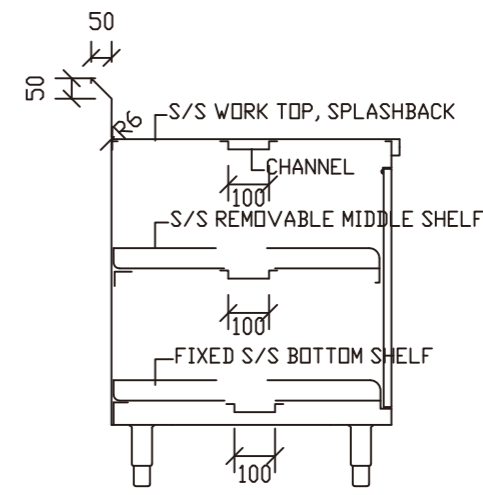

SECTION

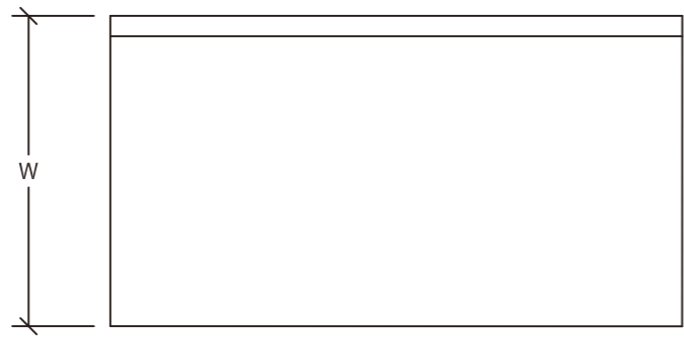

PLAN

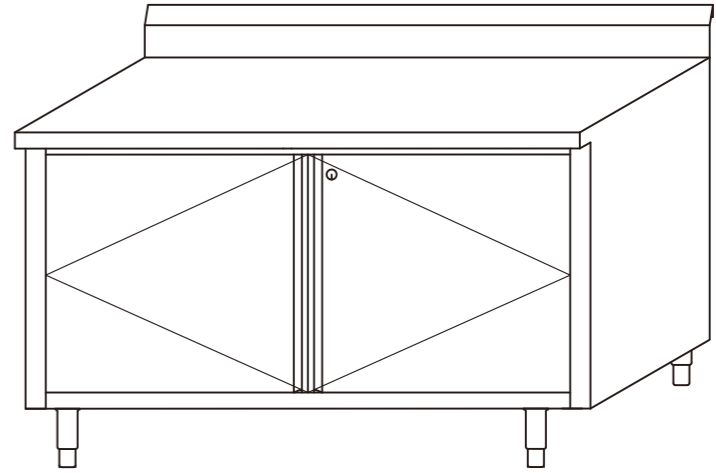

ISOMETRIC VIEW

No:	Item No(款号):	Qty(数量):	No:	Item No(款号):	Qty(数量):

Remark(备注):

M5

SPOT WELDED A THREADED SHAFT TO THE UNDERSIDE OF WORK TOP / SHELF. THEN USE UNITS TO FIX WITH THE REINFORCEMENT / BRACKETS

技术说明:				SKU:			
1.所有产品边缘不能有毛刺, 覆膜面不能刮花;				名称:	建德C40+潜水俱乐部厨房		
2.公差要求标准: 符合GB/T G3280-2015不锈钢冷轧钢板和钢带标准中PT.A的公称宽度要求;				材料:			
3.所有标注尺寸为外尺寸;				编制:		日期:	
4.未注膜面方向朝外。				审核:		日期:	
A						视角:	
版本			批准	日期		版本:	A

STAINLESS STEEL SHOP DRAWING (CUSTOM)

不锈钢件生产要求图

Product Description (产品说明):	Wash Sink
	三星
Model Type (模具型号):	SPSC3P J01

No:	Parts(零部件):	Material Specfication(用料标准):
✓ 01	COUNTER TOP 柜台面	16GA. THK. SUS 304 S/S
✓ 02	LEG 支腿	∅38mm 16 GA. THK. SUS 304 S/S TUBE
✓ 03	ADJUSTABLE FOOT INSERT 可调节嵌入式底脚	LUI CHUEN KEE (CHN)
✓ 04	REINFORCEMENT 加固件	16 GA. THK. SUS 304 S/S
✓ 05	SINK BOWL 洗碗槽	16 GA. THK. SUS 304 S/S
06	SINK WASTE 废料槽	
✓ 07	S.S. CROSS RAIL 横梁	∅32mm 16 GA. THK. SUS 304 S/S TUBE
08	WALL MOUNTED BRACKET 壁装托架	16 GA. THK. SUS 304 S/S
09	UNDER SHELF 底架	18 GA. THK. SUS 304 S/S
✓ 10	MIXING FAUCET 混合龙头	
✓ 11	OVER SHELF 顶架	18 GA. THK. SUS 304 S/S
12	OUTER DOOR PANEL 外板	20 GA. THK. SUS 304 S/S
13	INNER DOOR PANEL 内板	22 GA. THK. SUS 304 S/S
14	CABINET BODY 柜身	20 GA. THK. SUS 304 S/S
15	CORNER BUMPER 拐角防护套	COLSON (CHN)
16	SWIVEL CASTOR 旋转角轮	GLOBE (CHN)
17	SOUND DEADEN MATERIAL 隔音材料	3mm THICKNESS
18	WALL FLASHING 防水面	20 GA. THK. SUS 304 S/S
19	CONDENSING UNIT 制冷机组	DANFOSS (CHN)
20	NOZZLE 排气口	∅25mm SUS 304 S/S TUBE

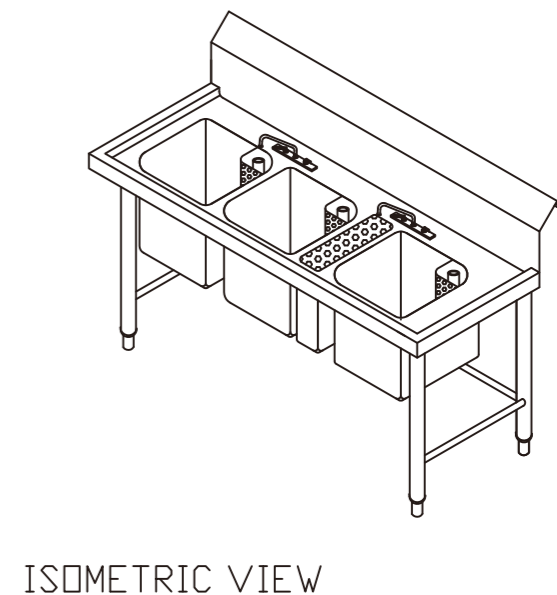
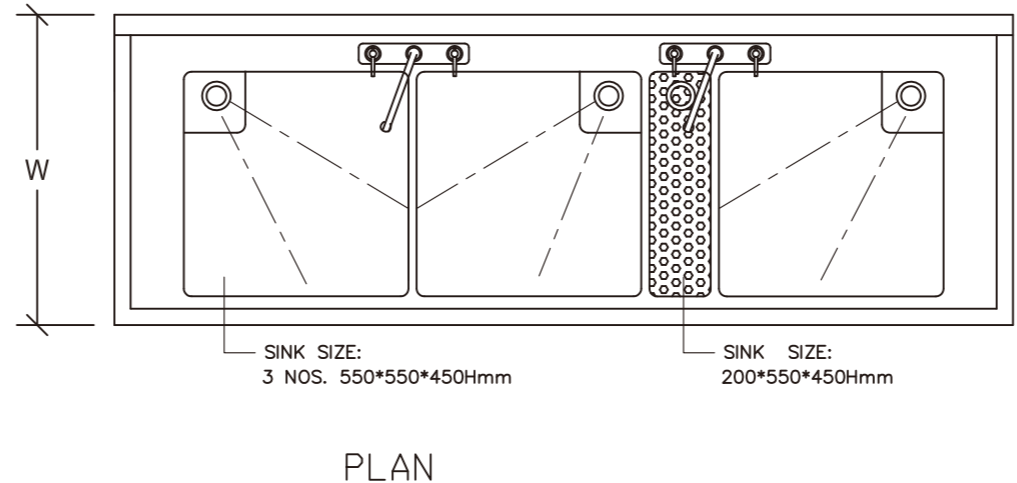
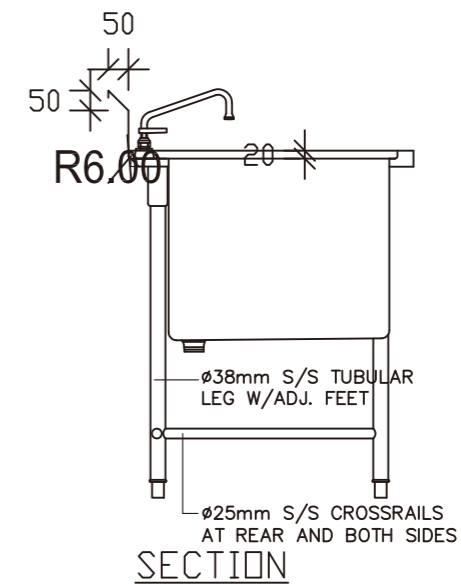
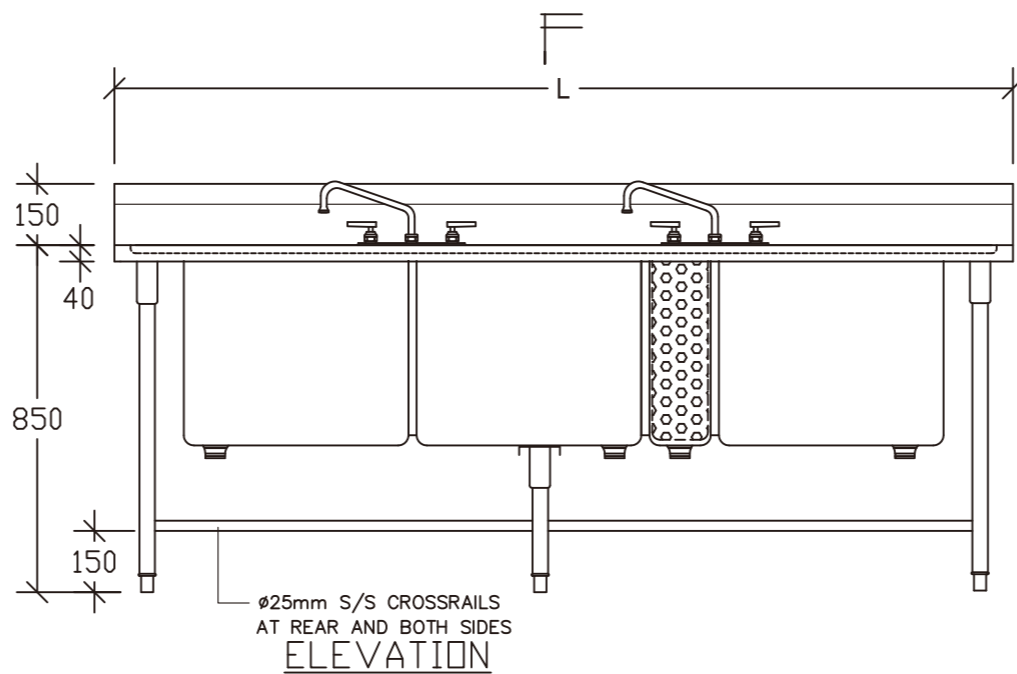

No:	Item No(款号):	Qty(数量):	No:	Item No(款号):	Qty(数量):

Remark(备注):

M5

SPOT WELDED A THREADED SHAFT TO THE UNDERSIDE OF WORK TOP / SHELF. THEN USE UNITS TO FIX WITH THE REINFORCEMENT / BRACKETS

技术说明:				SKU:			
1.所有产品边缘不能有毛刺, 覆膜面不能刮花;				名称:	建德C40+潜水俱乐部厨房		
2.公差要求标准: 符合GB/T G3280-2015不锈钢冷轧钢板和钢带标准中PT.A的公称宽度要求;				材料:			
3.所有标注尺寸为外尺寸;				编制:		日期:	
4.未注膜面方向朝外。				审核:		日期:	
A						视角:	☉
版本		批准	日期			版本:	A

STAINLESS STEEL SHOP DRAWING (CUSTOM)

不锈钢件生产要求图

Product Description (产品说明):	Single Wall Mounted Shelving
	单层挂墙层架
Model Type (模具型号):	JBW1 J02

No:	Parts(零部件):	Material Specification(用料标准):
01	COUNTER TOP 柜台面	16GA. THK. SUS 304 S/S
02	LEG 支腿	∅38mm 16 GA. THK. SUS 304 S/S TUBE
03	ADJUSTABLE FOOT INSERT 可调节嵌入式底脚	LUI CHUEN KEE (CHN)
✓ 04	REINFORCEMENT 加固件	16 GA. THK. SUS 304 S/S
05	SINK BOWL 洗碗槽	16 GA. THK. SUS 304 S/S
06	SINK WASTE 废料槽	
07	S.S. CROSS RAIL 横梁	∅32mm 16 GA. THK. SUS 304 S/S TUBE
✓ 08	WALL MOUNTED BRACKET 壁装托架	16 GA. THK. SUS 304 S/S
09	UNDER SHELF 底架	18 GA. THK. SUS 304 S/S
10	MIXING FAUCET 混合龙头	
✓ 11	OVER SHELF 顶架	18 GA. THK. SUS 304 S/S
12	OUTER DOOR PANEL 外板	20 GA. THK. SUS 304 S/S
13	INNER DOOR PANEL 内板	22 GA. THK. SUS 304 S/S
14	CABINET BODY 柜身	20 GA. THK. SUS 304 S/S
15	CORNER BUMPER 拐角防护套	COLSON (CHN)
16	SWIVEL CASTOR 旋转角轮	GLOBE (CHN)
17	SOUND DEADEN MATERIAL 隔音材料	3mm THICKNESS
18	WALL FLASHING 防水面	20 GA. THK. SUS 304 S/S
19	CONDENSING UNIT 制冷机组	DANFOSS (CHN)
20	NOZZLE 排气口	∅25mm SUS 304 S/S TUBE

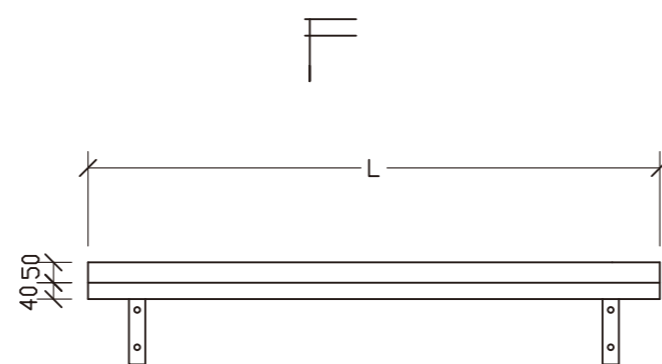

ELEVATION

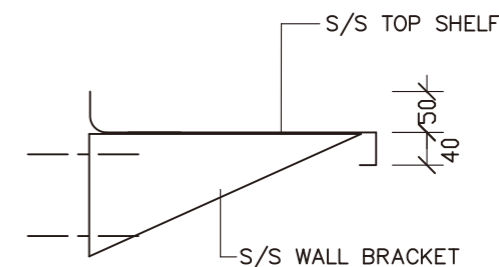

SECTION

No:	Item No(款号):	Qty(数量):	No:	Item No(款号):	Qty(数量):

Remark(备注):



SPOT WELDED A THREADED SHAFT TO THE UNDERSIDE OF WORK TOP / SHELF. THEN USE UNITS TO FIX WITH THE REINFORCEMENT / BRACKETS

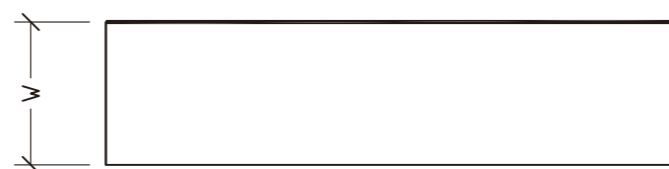

PLAN

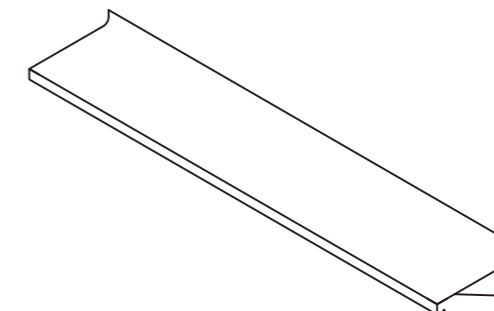

ISOMETRIC VIEW

技术说明:				SKU:			
1.所有产品边缘不能有毛刺, 覆膜面不能刮花;				名称:	建德C40+潜水俱乐部厨房		
2.公差要求标准: 符合GB/T G3280-2015不锈钢冷轧钢板和钢带标准中PT.A的公称宽度要求;				材料:			
3.所有标注尺寸为外尺寸;				编制:		日期:	
4.未注膜面方向朝外。				审核:		日期:	
A						视角:	☉
版本		批准	日期			版本:	A

STAINLESS STEEL SHOP DRAWING (CUSTOM)

不锈钢件生产要求图

Product Description (产品说明):	Work Table
	残菜回收台
Model Type (模具型号):	TB J03

No:	Parts(零部件):	Material Specfication(用料标准):
✓ 01	COUNTER TOP 柜台面	16GA. THK. SUS 304 S/S
✓ 02	LEG 支腿	∅38mm 16 GA. THK. SUS 304 S/S TUBE
✓ 03	ADJUSTABLE FOOT INSERT 可调节嵌入式底脚	LUI CHUEN KEE (CHN)
✓ 04	REINFORCEMENT 加固件	16 GA. THK. SUS 304 S/S
05	SINK BOWL 洗碗槽	16 GA. THK. SUS 304 S/S
06	SINK WASTE 废料槽	
✓ 07	S.S. CROSS RAIL 横梁	∅32mm 16 GA. THK. SUS 304 S/S TUBE
08	WALL MOUNTED BRACKET 壁装托架	16 GA. THK. SUS 304 S/S
09	UNDER SHELF 底架	18 GA. THK. SUS 304 S/S
10	MIXING FAUCET 混合龙头	
11	OVER SHELF 顶架	18 GA. THK. SUS 304 S/S
12	OUTER DOOR PANEL 外板	20 GA. THK. SUS 304 S/S
13	INNER DOOR PANEL 内板	22 GA. THK. SUS 304 S/S
14	CABINET BODY 柜身	20 GA. THK. SUS 304 S/S
15	CORNER BUMPER 拐角防护套	COLSON (CHN)
16	SWIVEL CASTOR 旋转角轮	GLOBE (CHN)
17	SOUND DEADEN MATERIAL 隔音材料	3mm THICKNESS
18	WALL FLASHING 防水面	20 GA. THK. SUS 304 S/S
19	CONDENSING UNIT 制冷机组	DANFOSS (CHN)
20	NOZZLE 排气口	∅25mm SUS 304 S/S TUBE

No:	Item No(款号):	Qty(数量):	No:	Item No(款号):	Qty(数量):

Remark(备注):

 M5

SPOT WELDED A THREADED SHAFT TO THE UNDERSIDE OF WORK TOP / SHELF. THEN USE UNITS TO FIX WITH THE REINFORCEMENT / BRACKETS

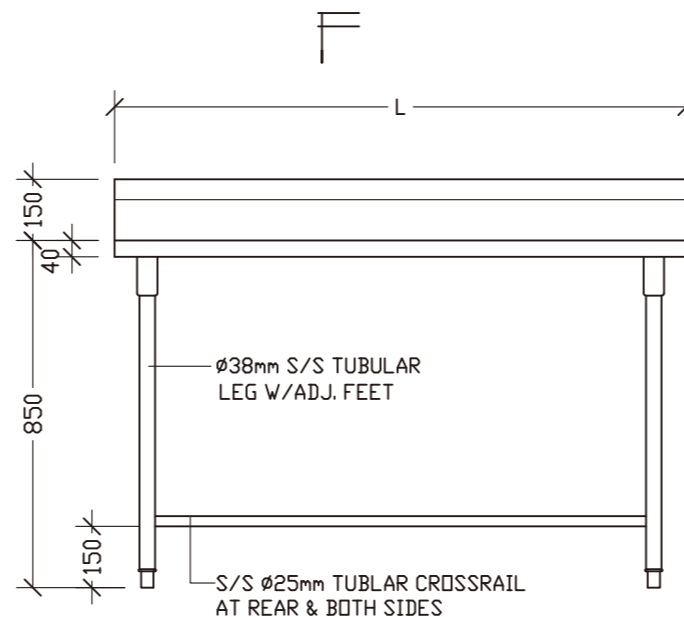

ELEVATION

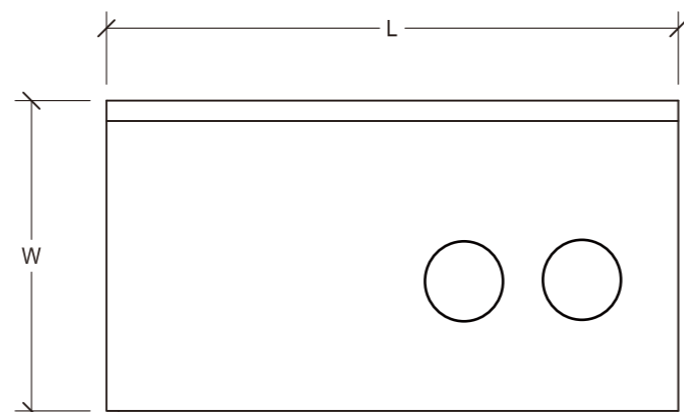

PLAN

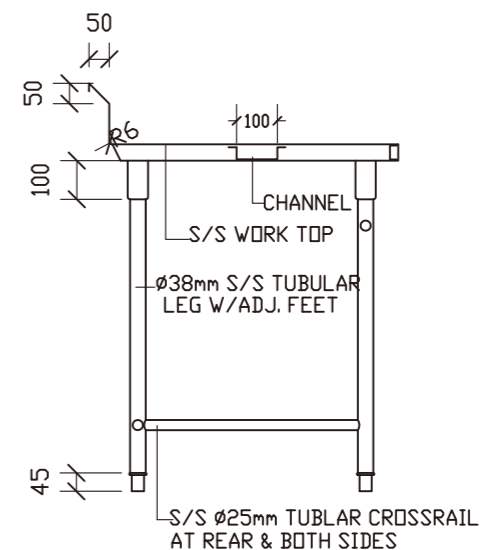

SECTION

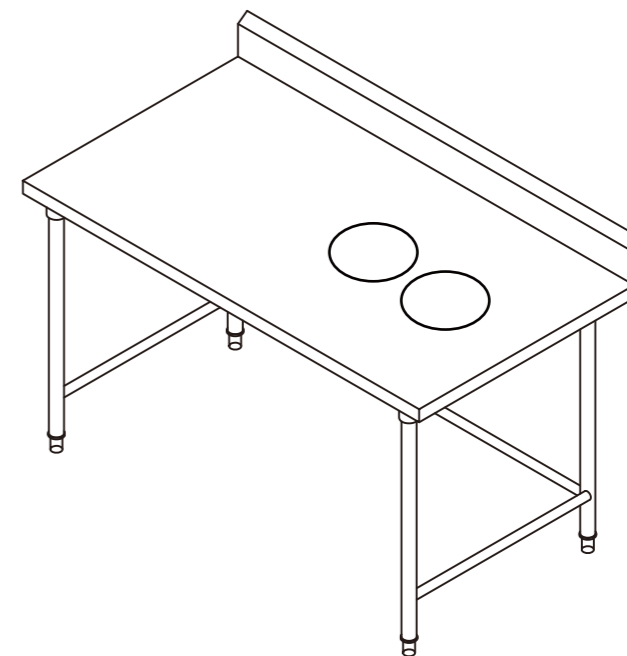

ISOMETRIC VIEW

技术说明:				SKU:			
1.所有产品边缘不能有毛刺, 覆膜面不能刮花;				名称:	建德C40+潜水俱乐部厨房		
2.公差要求标准: 符合GB/T G3280-2015不锈钢冷轧钢板和钢带标准中PT.A的公称宽度要求;				材料:			
3.所有标注尺寸为外尺寸;				编制:		日期:	
4.未注膜面方向朝外。				审核:		日期:	
A						视角:	
版本		批准	日期			版本:	A

STAINLESS STEEL SHOP DRAWING (CUSTOM)

不锈钢件生产要求图

Product Description (产品说明):	Dish Landing Table W/Double Sinks
	双星污碟台
Model Type (模具型号):	TDLSH2 J04

No:	Parts(零部件):	Material Specification(用料标准):
✓ 01	COUNTER TOP 柜台面	16GA. THK. SUS 304 S/S
✓ 02	LEG 支腿	∅38mm 16 GA. THK. SUS 304 S/S TUBE
✓ 03	ADJUSTABLE FOOT INSERT 可调节嵌入式底脚	LUI CHUEN KEE (CHN)
✓ 04	REINFORCEMENT 加固件	16 GA. THK. SUS 304 S/S
✓ 05	SINK BOWL 洗碗槽	16 GA. THK. SUS 304 S/S
06	SINK WASTE 废料槽	
✓ 07	S.S. CROSS RAIL 横梁	∅32mm 16 GA. THK. SUS 304 S/S TUBE
08	WALL MOUNTED BRACKET 壁装托架	16 GA. THK. SUS 304 S/S
09	UNDER SHELF 底架	18 GA. THK. SUS 304 S/S
✓ 10	MIXING FAUCET 混合龙头	
11	OVER SHELF 顶架	18 GA. THK. SUS 304 S/S
12	OUTER DOOR PANEL 外板	20 GA. THK. SUS 304 S/S
13	INNER DOOR PANEL 内板	22 GA. THK. SUS 304 S/S
14	CABINET BODY 柜身	20 GA. THK. SUS 304 S/S
15	CORNER BUMPER 拐角防护套	COLSON (CHN)
16	SWIVEL CASTOR 旋转角轮	GLOBE (CHN)
17	SOUND DEADEN MATERIAL 隔音材料	3mm THICKNESS
18	WALL FLASHING 防水面	20 GA. THK. SUS 304 S/S
19	CONDENSING UNIT 制冷机组	DANFOSS (CHN)
20	NOZZLE 排气口	∅25mm SUS 304 S/S TUBE

No:	Item No(款号):	Qty(数量):	No:	Item No(款号):	Qty(数量):

Remark(备注):

 M5

SPOT WELDED A THREADED SHAFT TO THE UNDERSIDE OF WORK TOP / SHELF. THEN USE UNITS TO FIX WITH THE REINFORCEMENT / BRACKETS

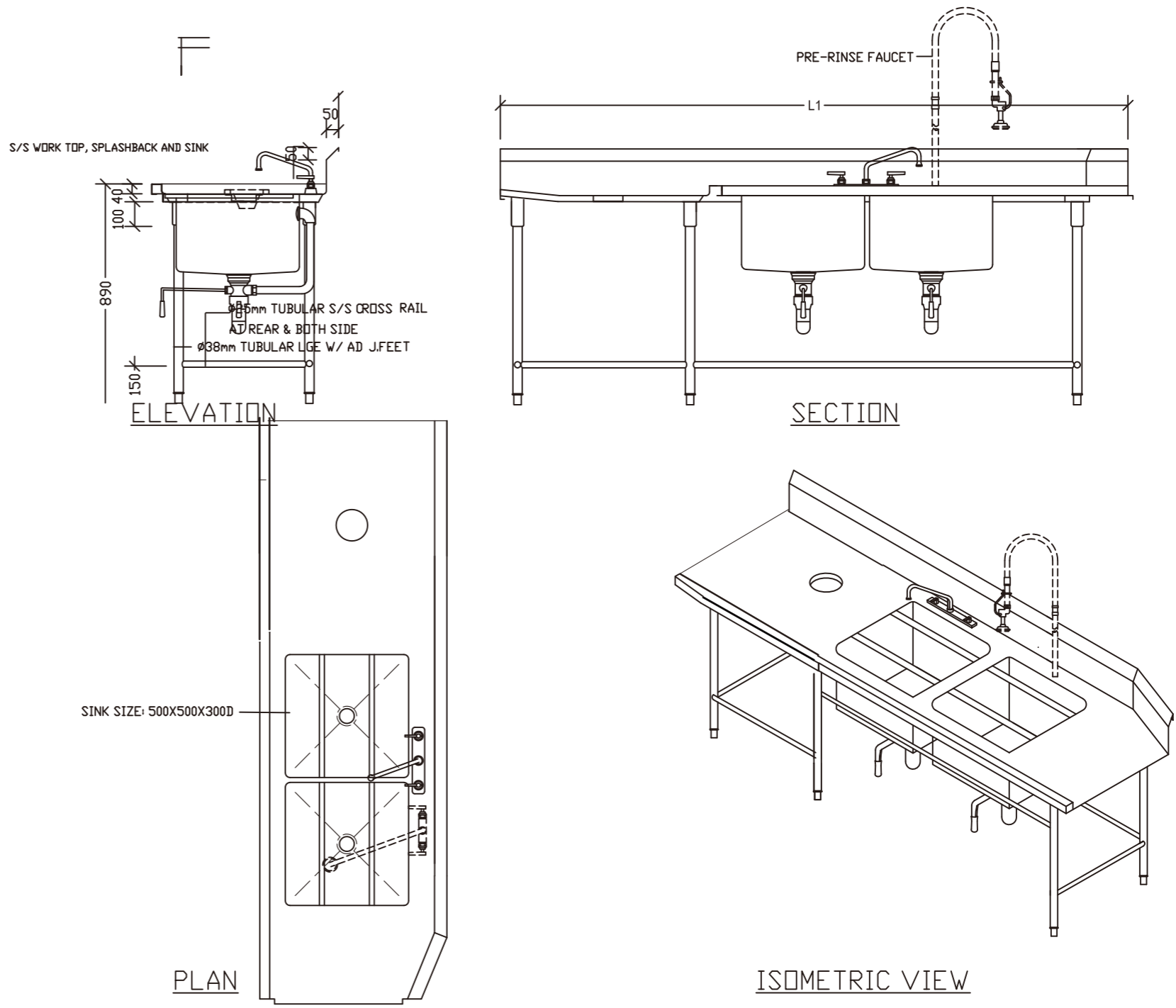

技术说明:				SKU:			
1.所有产品边缘不能有毛刺, 覆膜面不能刮花;				名称:	建德C40+潜水俱乐部厨房		
2.公差要求标准: 符合GB/T G3280-2015不锈钢冷轧钢板和钢带标准中PT.A的公称宽度要求;				材料:			
3.所有标注尺寸为外尺寸;				编制:		日期:	
4.未注膜面方向朝外。				审核:		日期:	
A						视角:	
版本		批准	日期			版本:	A

STAINLESS STEEL SHOP DRAWING (CUSTOM)

不锈钢件生产要求图

Product Description (产品说明):	Exhaust Canopy 集气罩
Model Type (模具型号):	EHSA J06

No:	Parts(零部件):	Material Specification(用料标准):
01	COUNTER TOP 柜台面	16GA. THK. SUS 304 S/S
02	LEG 支腿	∅38mm 16 GA. THK. SUS 304 S/S TUBE
03	ADJUSTABLE FOOT INSERT 可调节嵌入式底脚	LUI CHUEN KEE (CHN)
✓ 04	REINFORCEMENT 加固件	16 GA. THK. SUS 304 S/S
05	SINK BOWL 洗碗槽	16 GA. THK. SUS 304 S/S
06	SINK WASTE 废料槽	
07	S.S. CROSS RAIL 横梁	∅32mm 16 GA. THK. SUS 304 S/S TUBE
08	WALL MOUNTED BRACKET 壁装托架	16 GA. THK. SUS 304 S/S
09	UNDER SHELF 底架	18 GA. THK. SUS 304 S/S
10	MIXING FAUCET 混合龙头	
11	OVER SHELF 顶架	18 GA. THK. SUS 304 S/S
12	OUTER DOOR PANEL 外板	20 GA. THK. SUS 304 S/S
✓ 13	INNER DOOR PANEL 内板	22 GA. THK. SUS 304 S/S
✓ 14	CABINET BODY 柜身	20 GA. THK. SUS 304 S/S
15	CORNER BUMPER 拐角防护套	COLSON (CHN)
16	SWIVEL CASTOR 旋转角轮	GLOBE (CHN)
17	SOUND DEADEN MATERIAL 隔音材料	3mm THICKNESS
18	WALL FLASHING 防水面	20 GA. THK. SUS 304 S/S
19	CONDENSING UNIT 制冷机组	DANFOSS (CHN)
20	NOZZLE 排气口	∅25mm SUS 304 S/S TUBE

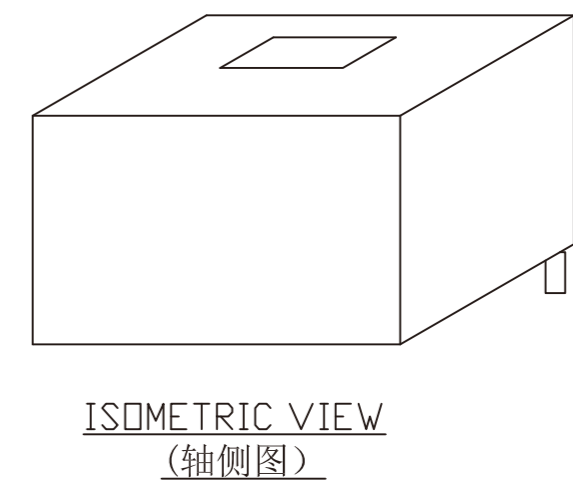
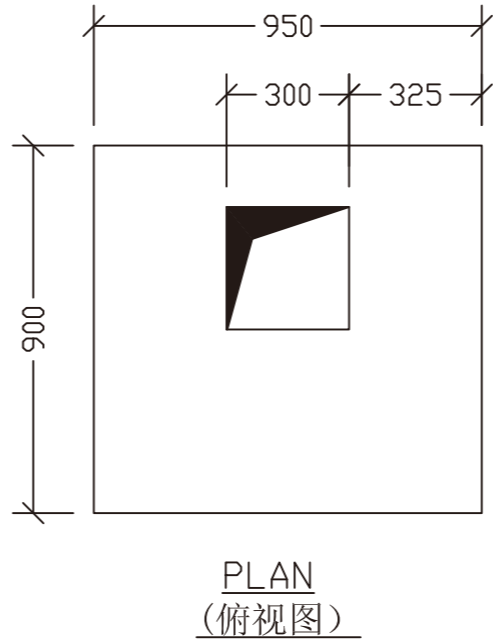
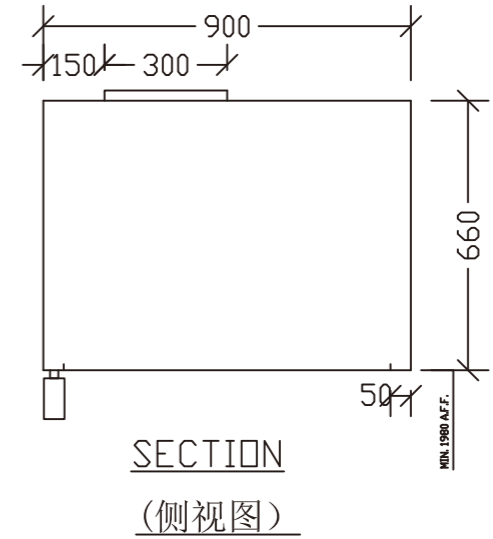
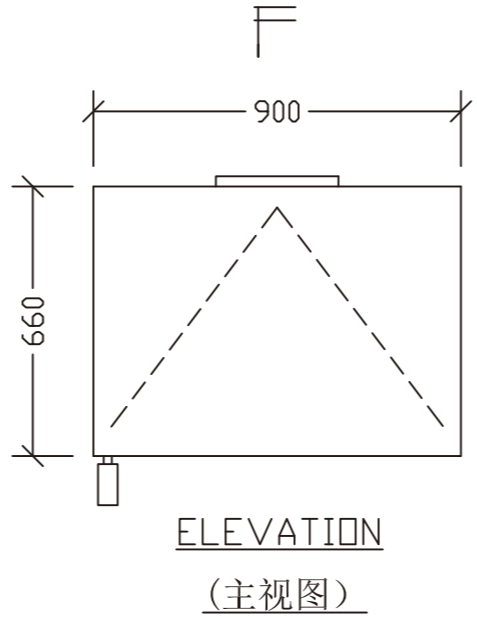

No:	Item No(款号):	Qty(数量):	No:	Item No(款号):	Qty(数量):

Remark(备注):

M5

SPOT WELDED A THREADED SHAFT TO THE UNDERSIDE OF WORK TOP / SHELF. THEN USE UNITS TO FIX WITH THE REINFORCEMENT / BRACKETS

技术说明: 1.所有产品边缘不能有毛刺, 覆膜面不能刮花; 2.公差要求标准: 符合GB/T G3280-2015不锈钢冷轧钢板和钢带标准中PT.A的公称宽度要求; 3.所有标注尺寸为外尺寸; 4.未注膜面方向朝外。				SKU:				
				名称:	建德C40+潜水俱乐部厨房			
				材料:				
				编制:		日期:		视角:
				审核:		日期:		版本: A
A								
版本				批准		日期		

STAINLESS STEEL SHOP DRAWING (CUSTOM)

不锈钢件生产要求图

Product Description (产品说明):	Clean Dish Landing Table
	洁碟台
Model Type (模具型号):	TCL J08

No:	Parts(零部件):	Material Specification(用料标准):
✓ 01	COUNTER TOP 柜台面	16GA. THK. SUS 304 S/S
✓ 02	LEG 支腿	Ø38mm 16 GA. THK. SUS 304 S/S TUBE
✓ 03	ADJUSTABLE FOOT INSERT 可调节嵌入式底脚	LUI CHUEN KEE (CHN)
✓ 04	REINFORCEMENT 加固件	16 GA. THK. SUS 304 S/S
05	SINK BOWL 洗碗槽	16 GA. THK. SUS 304 S/S
06	SINK WASTE 废料槽	
✓ 07	S.S. CROSS RAIL 横梁	Ø32mm 16 GA. THK. SUS 304 S/S TUBE
✓ 08	WALL MOUNTED BRACKET 壁装托架	16 GA. THK. SUS 304 S/S
09	UNDER SHELF 底架	18 GA. THK. SUS 304 S/S
10	MIXING FAUCET 混合龙头	
11	OVER SHELF 顶架	18 GA. THK. SUS 304 S/S
12	OUTER DOOR PANEL 外板	20 GA. THK. SUS 304 S/S
13	INNER DOOR PANEL 内板	22 GA. THK. SUS 304 S/S
14	CABINET BODY 柜身	20 GA. THK. SUS 304 S/S
15	CORNER BUMPER 拐角防护套	COLSON (CHN)
16	SWIVEL CASTOR 旋转角轮	GLOBE (CHN)
17	SOUND DEADEN MATERIAL 隔音材料	3mm THICKNESS
18	WALL FLASHING 防水面	20 GA. THK. SUS 304 S/S
19	CONDENSING UNIT 制冷机组	DANFOSS (CHN)
20	NOZZLE 排气口	Ø25mm SUS 304 S/S TUBE

No:	Item No(款号):	Qty(数量):	No:	Item No(款号):	Qty(数量):

Remark(备注):	
 M5	SPOT WELDED A THREADED SHAFT TO THE UNDERSIDE OF WORK TOP / SHELF. THEN USE UNITS TO FIX WITH THE REINFORCEMENT / BRACKETS

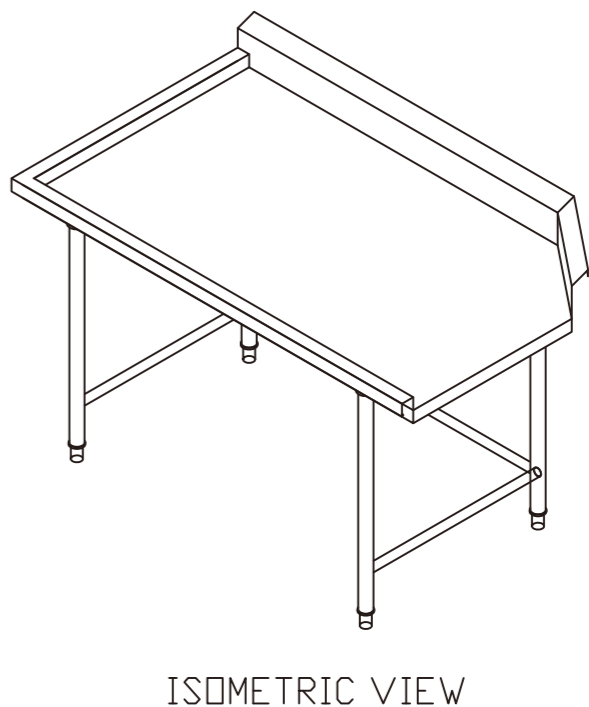
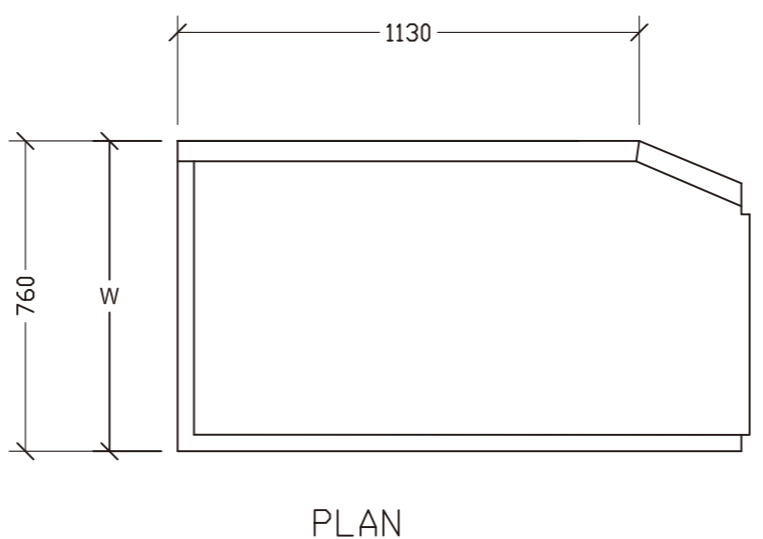
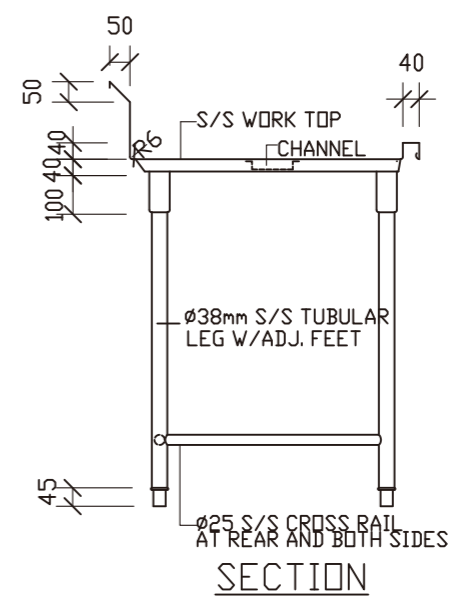
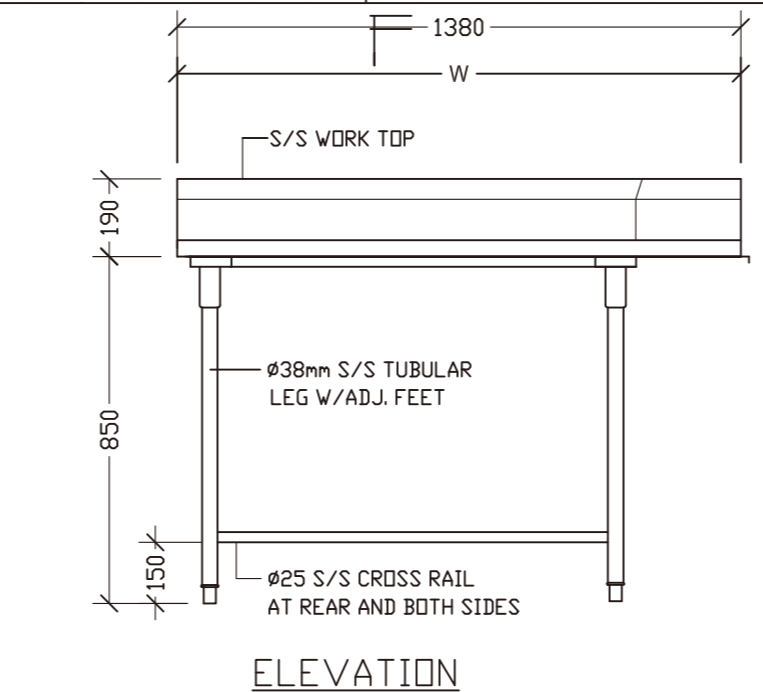

技术说明:				SKU:			
1.所有产品边缘不能有毛刺, 覆膜面不能刮花;				名称:	建德C40+潜水俱乐部厨房		
2.公差要求标准: 符合GB/T G3280-2015不锈钢冷轧钢板和钢带标准中PT.A的公称宽度要求;				材料:			
3.所有标注尺寸为外尺寸;				编制:		日期:	
4.未注膜面方向朝外。				审核:		日期:	
A						视角:	
版本		批准	日期			版本:	A

STAINLESS STEEL SHOP DRAWING (CUSTOM)

不锈钢件生产要求图

Product Description (产品说明):	Ceiling Mounted Dish Rack
	挂墙茜架
Model Type (模具型号):	JCWB J09

No:	Parts(零部件):	Material Specfication(用料标准):
01	COUNTER TOP 柜台面	16GA. THK. SUS 304 S/S
02	LEG 支腿	∅38mm 16 GA. THK. SUS 304 S/S TUBE
03	ADJUSTABLE FOOT INSERT 可调节嵌入式底脚	LUI CHUEN KEE (CHN)
✓ 04	REINFORCEMENT 加固件	16 GA. THK. SUS 304 S/S
05	SINK BOWL 洗碗槽	16 GA. THK. SUS 304 S/S
06	SINK WASTE 废料槽	
07	S.S. CROSS RAIL 横梁	∅32mm 16 GA. THK. SUS 304 S/S TUBE
08	WALL MOUNTED BRACKET 壁装托架	16 GA. THK. SUS 304 S/S
09	UNDER SHELF 底架	18 GA. THK. SUS 304 S/S
10	MIXING FAUCET 混合龙头	
✓ 11	OVER SHELF 顶架	18 GA. THK. SUS 304 S/S
12	OUTER DOOR PANEL 外板	20 GA. THK. SUS 304 S/S
13	INNER DOOR PANEL 内板	22 GA. THK. SUS 304 S/S
14	CABINET BODY 柜身	20 GA. THK. SUS 304 S/S
15	CORNER BUMPER 拐角防护套	COLSON (CHN)
16	SWIVEL CASTOR 旋转角轮	GLOBE (CHN)
17	SOUND DEADEN MATERIAL 隔音材料	3mm THICKNESS
18	WALL FLASHING 防水面	20 GA. THK. SUS 304 S/S
19	CONDENSING UNIT 制冷机组	DANFOSS (CHN)
20	NOZZLE 排气口	∅25mm SUS 304 S/S TUBE

No:	Item No(款号):	Qty(数量):	No:	Item No(款号):	Qty(数量):

Remark(备注):



SPOT WELDED A THREADED SHAFT TO THE UNDERSIDE OF WORK TOP / SHELF. THEN USE UNITS TO FIX WITH THE REINFORCEMENT / BRACKETS

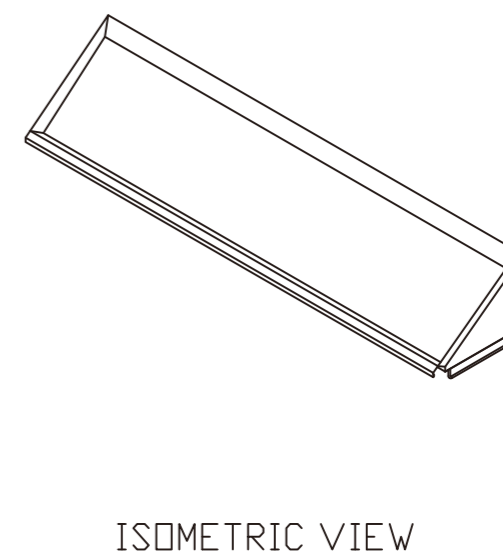
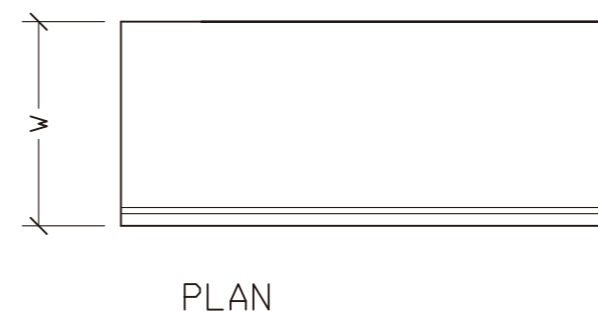
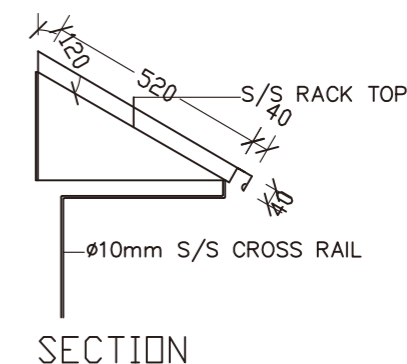
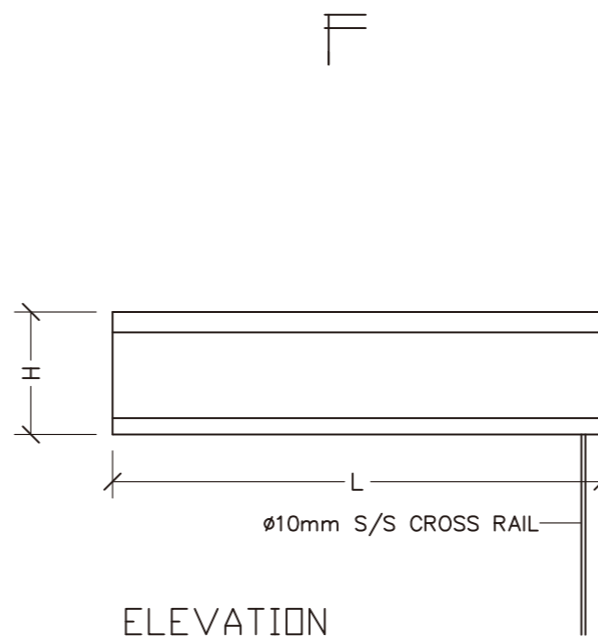

技术说明:				SKU:			
1.所有产品边缘不能有毛刺, 覆膜面不能刮花;				名称:	建德C40+潜水俱乐部厨房		
2.公差要求标准: 符合GB/T G3280-2015不锈钢冷轧钢板和钢带标准中PT.A的公称宽度要求;				材料:			
3.所有标注尺寸为外尺寸;				编制:		日期:	
4.未注膜面方向朝外。				审核:		日期:	
A						视角:	☉
版本		批准	日期			版本:	A

STAINLESS STEEL SHOP DRAWING (CUSTOM)

不锈钢件生产要求图

Product Description (产品说明):	Uright Storage Cabinet
	高身储物柜
Model Type (模具型号):	CUS J11

No:	Parts(零部件):	Material Specfication(用料标准):
✓ 01	COUNTER TOP 柜台面	16GA. THK. SUS 304 S/S
02	LEG 支腿	∅38mm 16 GA. THK. SUS 304 S/S TUBE
✓ 03	ADJUSTABLE FOOT INSERT 可调节嵌入式底脚	LUI CHUEN KEE (CHN)
✓ 04	REINFORCEMENT 加固件	16 GA. THK. SUS 304 S/S
05	SINK BOWL 洗碗槽	16 GA. THK. SUS 304 S/S
06	SINK WASTE 废料槽	
07	S.S. CROSS RAIL 横梁	∅32mm 16 GA. THK. SUS 304 S/S TUBE
08	WALL MOUNTED BRACKET 壁装托架	16 GA. THK. SUS 304 S/S
✓ 09	UNDER SHELF 底架	18 GA. THK. SUS 304 S/S
10	MIXING FAUCET 混合龙头	
11	OVER SHELF 顶架	18 GA. THK. SUS 304 S/S
✓ 12	OUTER DOOR PANEL 外板	20 GA. THK. SUS 304 S/S
✓ 13	INNER DOOR PANEL 内板	22 GA. THK. SUS 304 S/S
✓ 14	CABINET BODY 柜身	20 GA. THK. SUS 304 S/S
15	CORNER BUMPER 拐角防护套	COLSON (CHN)
16	SWIVEL CASTOR 旋转角轮	GLOBE (CHN)
17	SOUND DEADEN MATERIAL 隔音材料	3mm THICKNESS
18	WALL FLASHING 防水面	20 GA. THK. SUS 304 S/S
19	CONDENSING UNIT 制冷机组	DANFOSS (CHN)
20	NOZZLE 排气口	∅25mm SUS 304 S/S TUBE

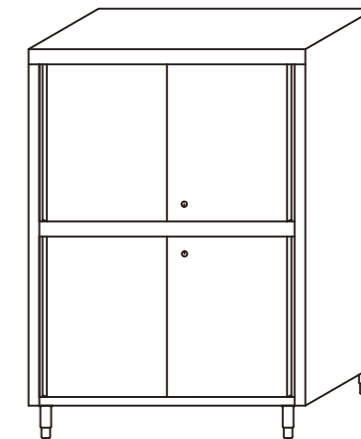
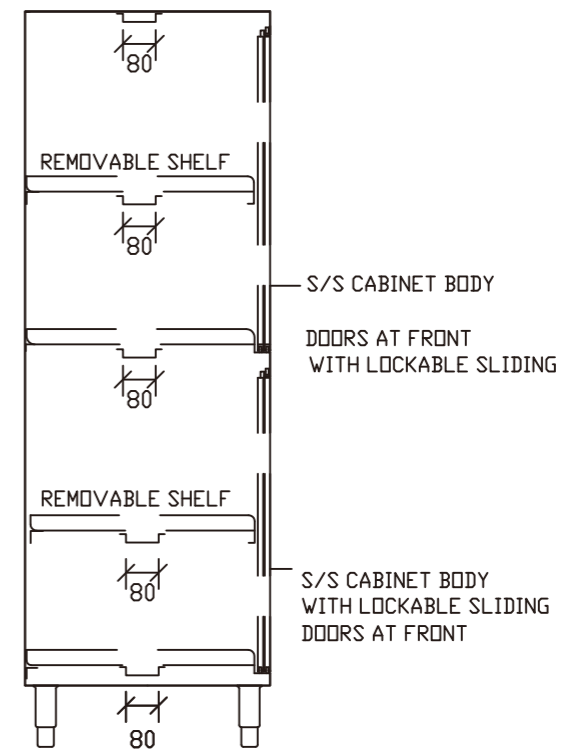
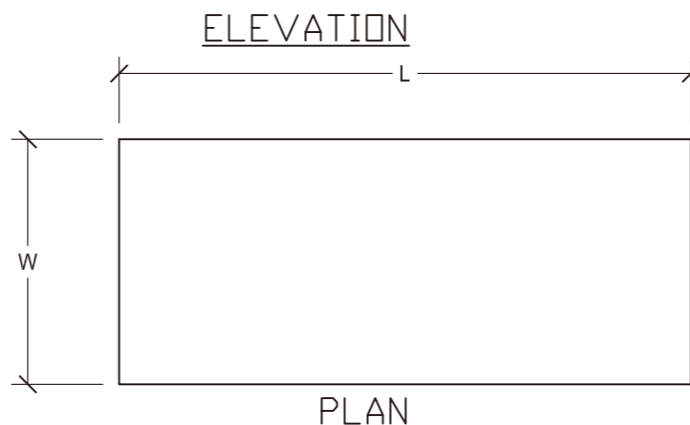
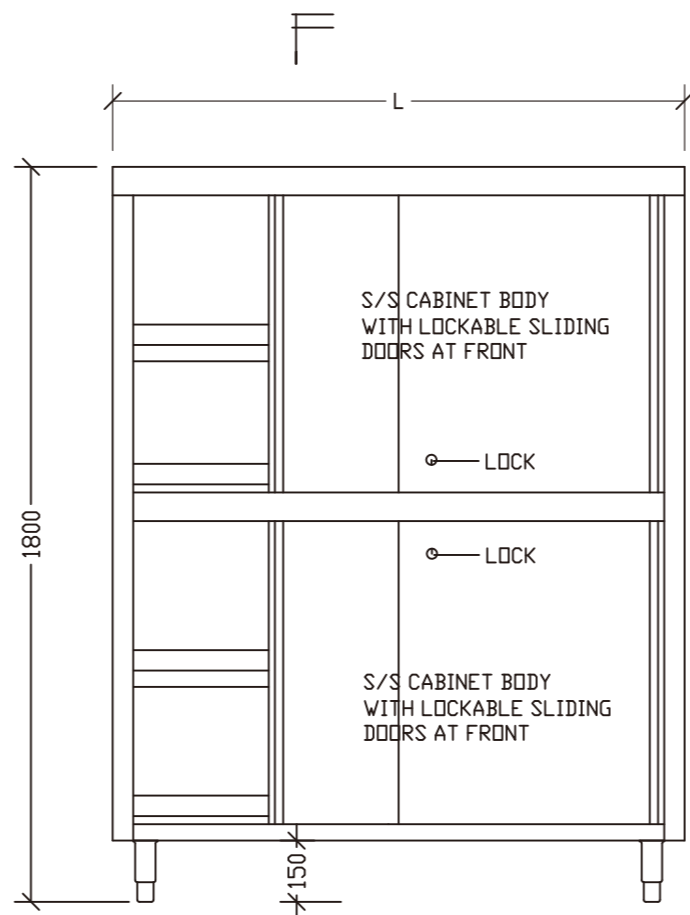

No:	Item No(款号):	Qty(数量):	No:	Item No(款号):	Qty(数量):

Remark(备注):



SPOT WELDED A THREADED SHAFT TO THE UNDERSIDE OF WORK TOP / SHELF. THEN USE UNITS TO FIX WITH THE REINFORCEMENT / BRACKETS

技术说明:
 1.所有产品边缘不能有毛刺, 覆膜面不能刮花;
 2.公差要求标准: 符合GB/T G3280-2015不锈钢冷轧钢板和钢带标准中PT.A的公称宽度要求;
 3.所有标注尺寸为外尺寸;
 4.未注膜面方向朝外。

SKU:
 名称: 建德C40+潜水俱乐部厨房
 材料:
 编制:
 审核:

日期:
 日期:
 视角:
 版本: A

版本 A
 批准
 日期

STAINLESS STEEL SHOP DRAWING (CUSTOM)

不锈钢件生产要求图

Product Description (产品说明):	Hand Wash Sink
	挂墙洗手星盆
Model Type (模具型号):	SHSC1-W K02

No:	Parts(零部件):	Material Specfication(用料标准):
✓ 01	COUNTER TOP 柜台面	16GA. THK. SUS 304 S/S
02	LEG 支腿	∅38mm 16 GA. THK. SUS 304 S/S TUBE
03	ADJUSTABLE FOOT INSERT 可调节嵌入式底脚	LUI CHUEN KEE (CHN)
✓ 04	REINFORCEMENT 加固件	16 GA. THK. SUS 304 S/S
✓ 05	SINK BOWL 洗碗槽	16 GA. THK. SUS 304 S/S
06	SINK WASTE 废料槽	
07	S.S. CROSS RAIL 横梁	∅32mm 16 GA. THK. SUS 304 S/S TUBE
✓ 08	WALL MOUNTED BRACKET 壁装托架	16 GA. THK. SUS 304 S/S
09	UNDER SHELF 底架	18 GA. THK. SUS 304 S/S
✓ 10	MIXING FAUCET 混合龙头	
11	OVER SHELF 顶架	18 GA. THK. SUS 304 S/S
12	OUTER DOOR PANEL 外板	20 GA. THK. SUS 304 S/S
13	INNER DOOR PANEL 内板	22 GA. THK. SUS 304 S/S
14	CABINET BODY 柜身	20 GA. THK. SUS 304 S/S
15	CORNER BUMPER 拐角防护套	COLSON (CHN)
16	SWIVEL CASTOR 旋转角轮	GLOBE (CHN)
17	SOUND DEADEN MATERIAL 隔音材料	3mm THICKNESS
18	WALL FLASHING 防水面	20 GA. THK. SUS 304 S/S
19	CONDENSING UNIT 制冷机组	DANFOSS (CHN)
20	NOZZLE 排气口	∅25mm SUS 304 S/S TUBE

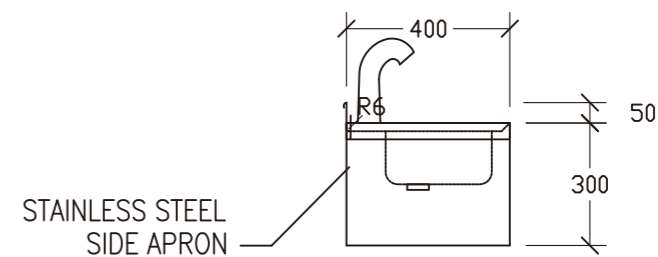
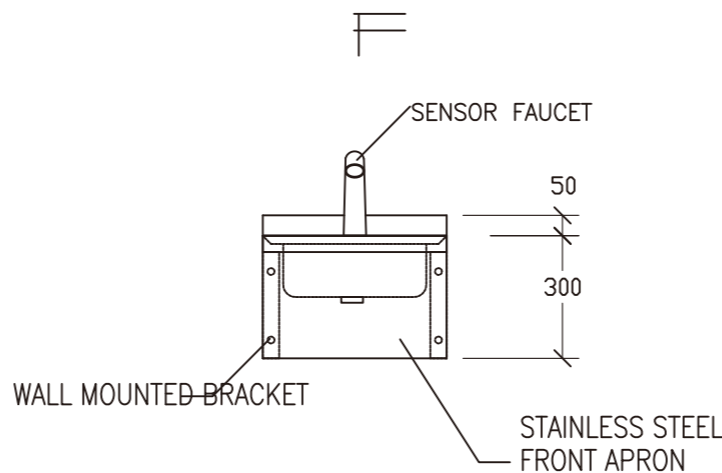

ELEVATION

SECTION

No:	Item No(款号):	Qty(数量):	No:	Item No(款号):	Qty(数量):

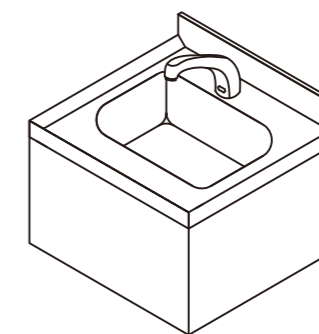
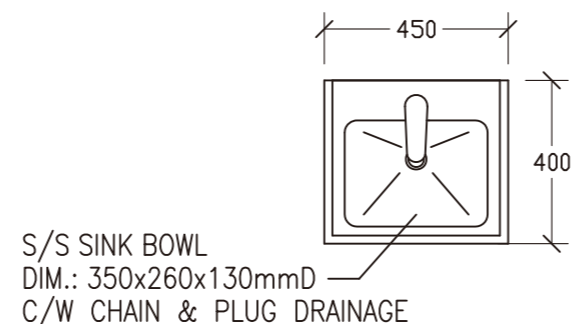

Remark(备注):



SPOT WELDED A THREADED SHAFT TO THE UNDERSIDE OF WORK TOP / SHELF. THEN USE UNITS TO FIX WITH THE REINFORCEMENT / BRACKETS

技术说明:				SKU:			
1.所有产品边缘不能有毛刺, 覆膜面不能刮花;				名称:	建德C40+潜水俱乐部厨房		
2.公差要求标准: 符合GB/T G3280-2015不锈钢冷轧钢板和钢带标准中PT.A的公称宽度要求;				材料:			
3.所有标注尺寸为外尺寸;				编制:		日期:	
4.未注膜面方向朝外。				审核:		日期:	
A						视角:	☉
版本		批准	日期			版本:	A

STAINLESS STEEL SHOP DRAWING (CUSTOM)

不锈钢件生产要求图

Product Description (产品说明):	Work Table W/Twin Sinks
	工作台连双星盆 (中间去水)
Model Type (模具型号):	STSH1 K05

No:	Parts(零部件):	Material Specification(用料标准):
✓ 01	COUNTER TOP 柜台面	16GA. THK. SUS 304 S/S
✓ 02	LEG 支腿	∅38mm 16 GA. THK. SUS 304 S/S TUBE
✓ 03	ADJUSTABLE FOOT INSERT 可调节嵌入式底脚	LUI CHUEN KEE (CHN)
✓ 04	REINFORCEMENT 加固件	16 GA. THK. SUS 304 S/S
✓ 05	SINK BOWL 洗碗槽	16 GA. THK. SUS 304 S/S
06	SINK WASTE 废料槽	
✓ 07	S.S. CROSS RAIL 横梁	∅32mm 16 GA. THK. SUS 304 S/S TUBE
08	WALL MOUNTED BRACKET 壁装托架	16 GA. THK. SUS 304 S/S
09	UNDER SHELF 底架	18 GA. THK. SUS 304 S/S
✓ 10	MIXING FAUCET 混合龙头	
11	OVER SHELF 顶架	18 GA. THK. SUS 304 S/S
12	OUTER DOOR PANEL 外板	20 GA. THK. SUS 304 S/S
13	INNER DOOR PANEL 内板	22 GA. THK. SUS 304 S/S
14	CABINET BODY 柜身	20 GA. THK. SUS 304 S/S
15	CORNER BUMPER 拐角防护套	COLSON (CHN)
16	SWIVEL CASTOR 旋转角轮	GLOBE (CHN)
17	SOUND DEADEN MATERIAL 隔音材料	3mm THICKNESS
18	WALL FLASHING 防水面	20 GA. THK. SUS 304 S/S
19	CONDENSING UNIT 制冷机组	DANFOSS (CHN)
20	NOZZLE 排气口	∅25mm SUS 304 S/S TUBE

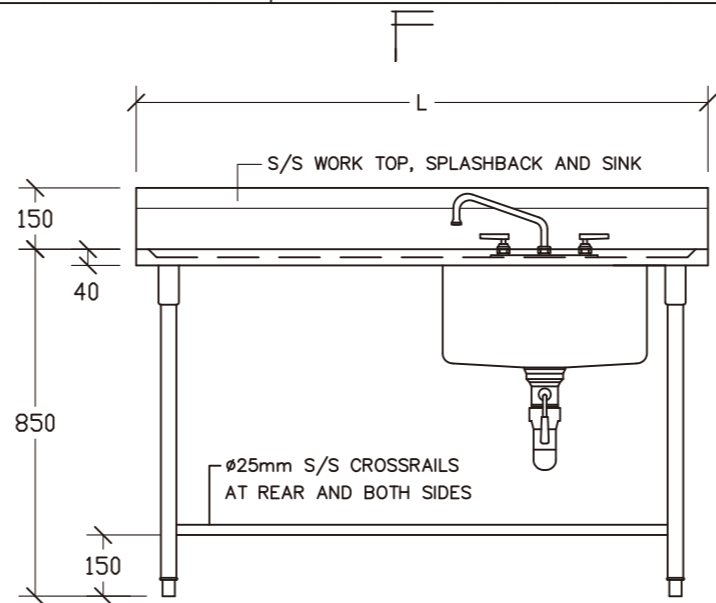

ELEVATION

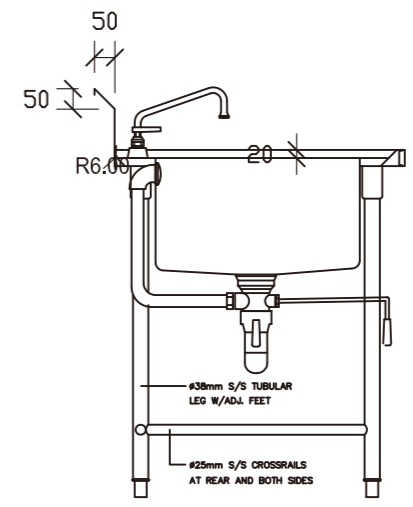

SECTION

No:	Item No(款号):	Qty(数量):	No:	Item No(款号):	Qty(数量):

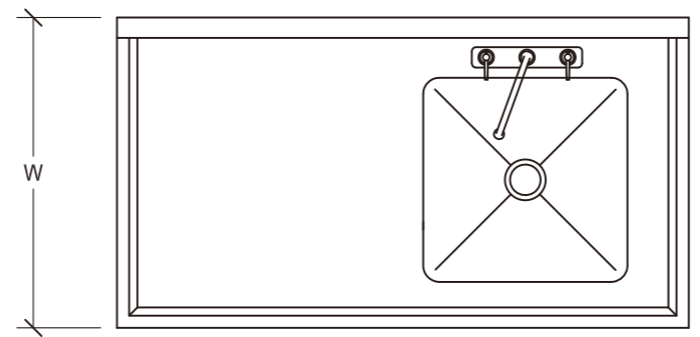

PLAN

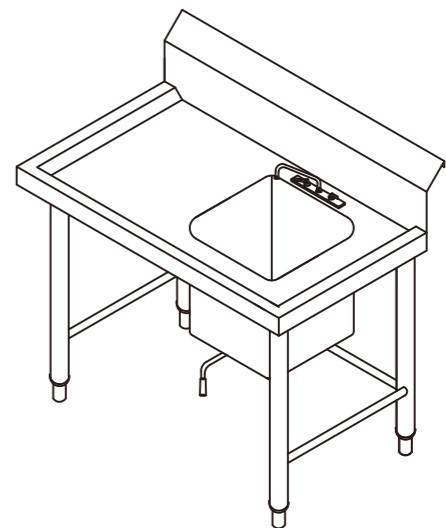

ISOMETRIC VIEW

Remark(备注):

 M5

SPOT WELDED A THREADED SHAFT TO THE UNDERSIDE OF WORK TOP / SHELF. THEN USE UNITS TO FIX WITH THE REINFORCEMENT / BRACKETS

技术说明:				SKU:			
1.所有产品边缘不能有毛刺, 覆膜面不能刮花;				名称:	建德C40+潜水俱乐部厨房		
2.公差要求标准: 符合GB/T G3280-2015不锈钢冷轧钢板和钢带标准中PT.A的公称宽度要求;				材料:			
3.所有标注尺寸为外尺寸;				编制:		日期:	
4.未注膜面方向朝外。				审核:		日期:	
A						视角:	
版本		批准	日期			版本:	A

STAINLESS STEEL SHOP DRAWING (CUSTOM)

不锈钢件生产要求图

Product Description (产品说明):	4-Tier Square Tube Storage Shelving
	四层通架
Model Type (模具型号):	JFG4 L01

No:	Parts(零部件):	Material Specification(用料标准):
01	COUNTER TOP 柜台面	16GA. THK. SUS 304 S/S
✓ 02	LEG 支腿	∅38mm 16 GA. THK. SUS 304 S/S TUBE
✓ 03	ADJUSTABLE FOOT INSERT 可调节嵌入式底脚	LUI CHUEN KEE (CHN)
04	REINFORCEMENT 加固件	16 GA. THK. SUS 304 S/S
05	SINK BOWL 洗碗槽	16 GA. THK. SUS 304 S/S
06	SINK WASTE 废料槽	
✓ 07	S.S. CROSS RAIL 横梁	∅32mm 16 GA. THK. SUS 304 S/S TUBE
08	WALL MOUNTED BRACKET 壁装托架	16 GA. THK. SUS 304 S/S
09	UNDER SHELF 底架	18 GA. THK. SUS 304 S/S
10	MIXING FAUCET 混合龙头	
11	OVER SHELF 顶架	18 GA. THK. SUS 304 S/S
12	OUTER DOOR PANEL 外板	20 GA. THK. SUS 304 S/S
13	INNER DOOR PANEL 内板	22 GA. THK. SUS 304 S/S
14	CABINET BODY 柜身	20 GA. THK. SUS 304 S/S
15	CORNER BUMPER 拐角防护套	COLSON (CHN)
16	SWIVEL CASTOR 旋转角轮	GLOBE (CHN)
17	SOUND DEADEN MATERIAL 隔音材料	3mm THICKNESS
18	WALL FLASHING 防水面	20 GA. THK. SUS 304 S/S
19	CONDENSING UNIT 制冷机组	DANFOSS (CHN)
20	NOZZLE 排气口	∅25mm SUS 304 S/S TUBE

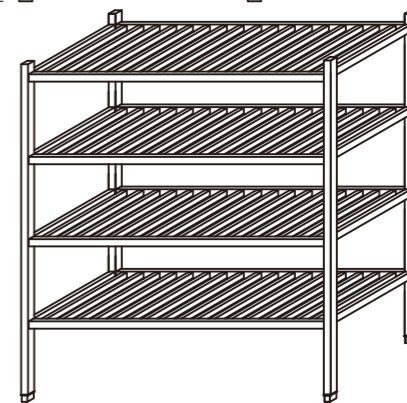
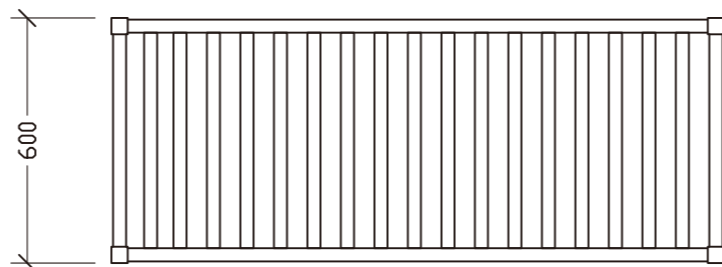
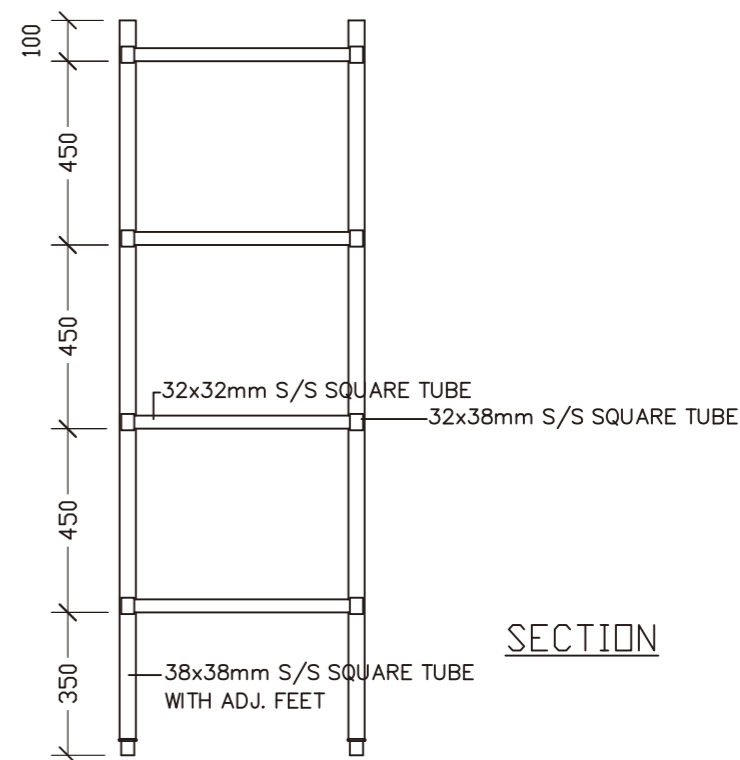
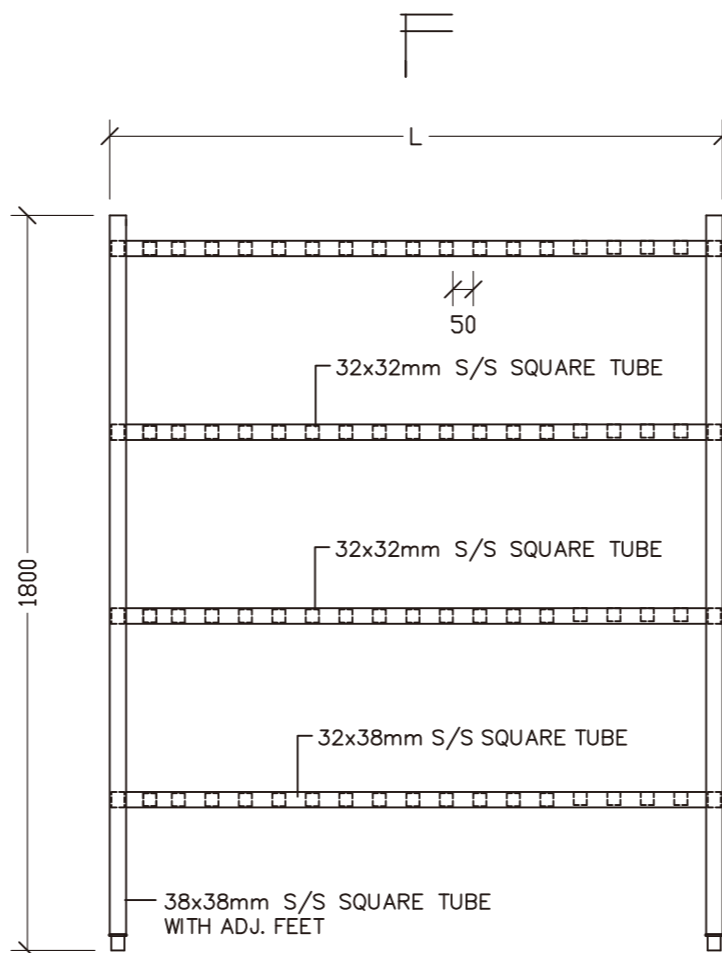

No:	Item No(款号):	Qty(数量):	No:	Item No(款号):	Qty(数量):

Remark(备注):



SPOT WELDED A THREADED SHAFT TO THE UNDERSIDE OF WORK TOP / SHELF. THEN USE UNITS TO FIX WITH THE REINFORCEMENT / BRACKETS

技术说明:
 1.所有产品边缘不能有毛刺, 覆膜面不能刮花;
 2.公差要求标准: 符合GB/T G3280-2015不锈钢冷轧钢板和钢带标准中PT.A的公称宽度要求;
 3.所有标注尺寸为外尺寸;
 4.未注膜面方向朝外。

SKU:
 名称: 建德C40+潜水俱乐部厨房
 材料:
 编制:
 审核:

日期:
 日期:
 视角:
 版本: A

STAINLESS STEEL SHOP DRAWING (CUSTOM)

不锈钢件生产要求图

Product Description (产品说明):	Work Cabinet
	工作掩门柜
Model Type (模具型号):	CBH L04

No:	Parts(零部件):	Material Specification(用料标准):
✓ 01	COUNTER TOP 柜台面	16GA. THK. SUS 304 S/S
02	LEG 支腿	Ø38mm 16 GA. THK. SUS 304 S/S TUBE
✓ 03	ADJUSTABLE FOOT INSERT 可调节嵌入式底脚	LUI CHUEN KEE (CHN)
✓ 04	REINFORCEMENT 加固件	16 GA. THK. SUS 304 S/S
05	SINK BOWL 洗碗槽	16 GA. THK. SUS 304 S/S
06	SINK WASTE 废料槽	
07	S.S. CROSS RAIL 横梁	Ø32mm 16 GA. THK. SUS 304 S/S TUBE
08	WALL MOUNTED BRACKET 壁装托架	16 GA. THK. SUS 304 S/S
✓ 09	UNDER SHELF 底架	18 GA. THK. SUS 304 S/S
10	MIXING FAUCET 混合龙头	
11	OVER SHELF 顶架	18 GA. THK. SUS 304 S/S
✓ 12	OUTER DOOR PANEL 外板	20 GA. THK. SUS 304 S/S
✓ 13	INNER DOOR PANEL 内板	22 GA. THK. SUS 304 S/S
✓ 14	CABINET BODY 柜身	20 GA. THK. SUS 304 S/S
15	CORNER BUMPER 拐角防护套	COLSON (CHN)
16	SWIVEL CASTOR 旋转角轮	GLOBE (CHN)
17	SOUND DEADEN MATERIAL 隔音材料	3mm THICKNESS
18	WALL FLASHING 防水面	20 GA. THK. SUS 304 S/S
19	CONDENSING UNIT 制冷机组	DANFOSS (CHN)
20	NOZZLE 排气口	Ø25mm SUS 304 S/S TUBE

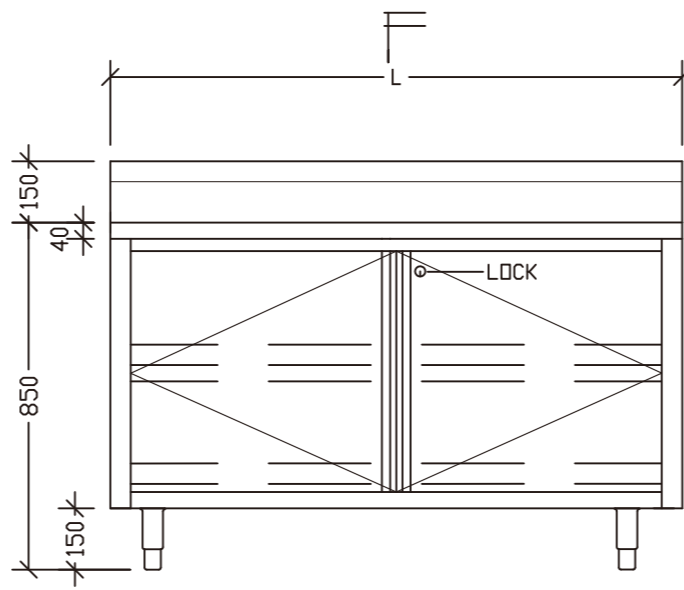

ELEVATION

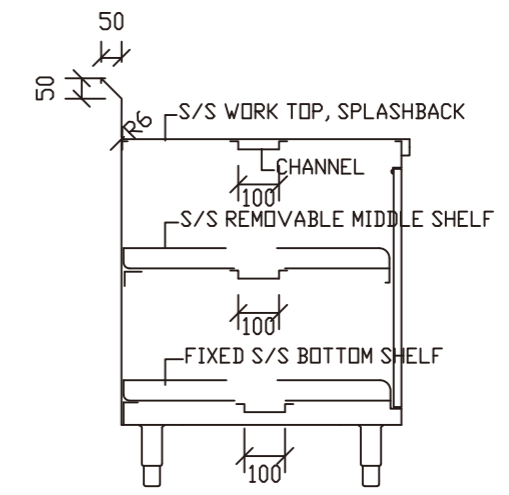

SECTION

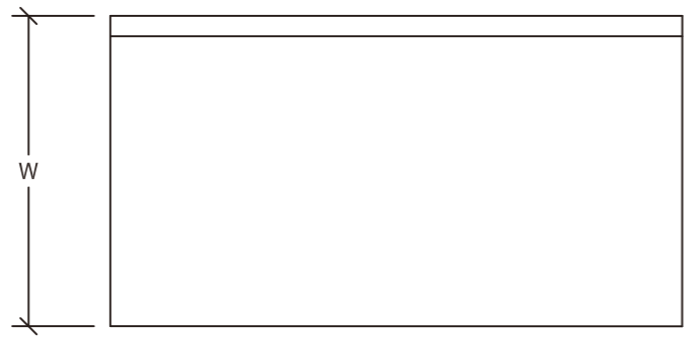

PLAN

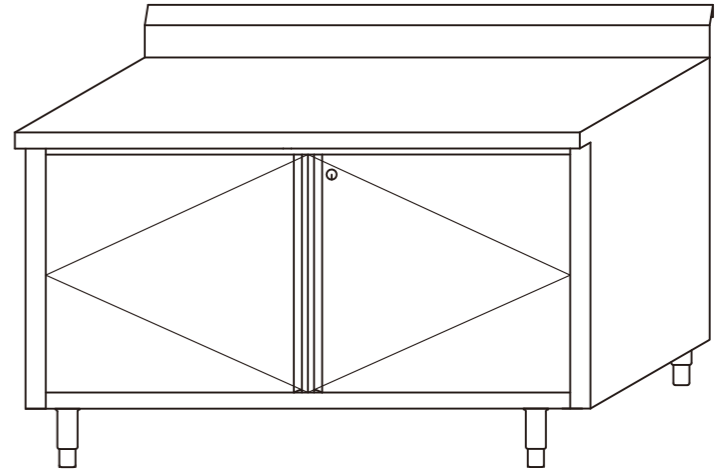

ISOMETRIC VIEW

No:	Item No(款号):	Qty(数量):	No:	Item No(款号):	Qty(数量):

Remark(备注):



SPOT WELDED A THREADED SHAFT TO THE UNDERSIDE OF WORK TOP / SHELF. THEN USE UNITS TO FIX WITH THE REINFORCEMENT / BRACKETS

技术说明:				SKU:			
1.所有产品边缘不能有毛刺, 覆膜面不能刮花;				名称:	建德C40+潜水俱乐部厨房		
2.公差要求标准: 符合GB/T G3280-2015不锈钢冷轧钢板和钢带标准中PT.A的公称宽度要求;				材料:			
3.所有标注尺寸为外尺寸;				编制:		日期:	
4.未注膜面方向朝外。				审核:		日期:	
A						视角:	☉
版本			批准	日期		版本:	A

STAINLESS STEEL SHOP DRAWING (CUSTOM)

不锈钢件生产要求图

Product Description (产品说明):	Work Table W/Twin Sinks
	工作台连双星盆 (中间去水)
Model Type (模具型号):	STSH2 L05

No:	Parts(零部件):	Material Specification(用料标准):
✓ 01	COUNTER TOP 柜台面	16GA. THK. SUS 304 S/S
✓ 02	LEG 支腿	∅38mm 16 GA. THK. SUS 304 S/S TUBE
✓ 03	ADJUSTABLE FOOT INSERT 可调节嵌入式底脚	LUI CHUEN KEE (CHN)
✓ 04	REINFORCEMENT 加固件	16 GA. THK. SUS 304 S/S
✓ 05	SINK BOWL 洗碗槽	16 GA. THK. SUS 304 S/S
06	SINK WASTE 废料槽	
✓ 07	S.S. CROSS RAIL 横梁	∅32mm 16 GA. THK. SUS 304 S/S TUBE
08	WALL MOUNTED BRACKET 壁装托架	16 GA. THK. SUS 304 S/S
09	UNDER SHELF 底架	18 GA. THK. SUS 304 S/S
✓ 10	MIXING FAUCET 混合龙头	
11	OVER SHELF 顶架	18 GA. THK. SUS 304 S/S
12	OUTER DOOR PANEL 外板	20 GA. THK. SUS 304 S/S
13	INNER DOOR PANEL 内板	22 GA. THK. SUS 304 S/S
14	CABINET BODY 柜身	20 GA. THK. SUS 304 S/S
15	CORNER BUMPER 拐角防护套	COLSON (CHN)
16	SWIVEL CASTOR 旋转角轮	GLOBE (CHN)
17	SOUND DEADEN MATERIAL 隔音材料	3mm THICKNESS
18	WALL FLASHING 防水面	20 GA. THK. SUS 304 S/S
19	CONDENSING UNIT 制冷机组	DANFOSS (CHN)
20	NOZZLE 排气口	∅25mm SUS 304 S/S TUBE

No:	Item No(款号):	Qty(数量):	No:	Item No(款号):	Qty(数量):

Remark(备注):

 M5

SPOT WELDED A THREADED SHAFT TO THE UNDERSIDE OF WORK TOP / SHELF. THEN USE UNITS TO FIX WITH THE REINFORCEMENT / BRACKETS

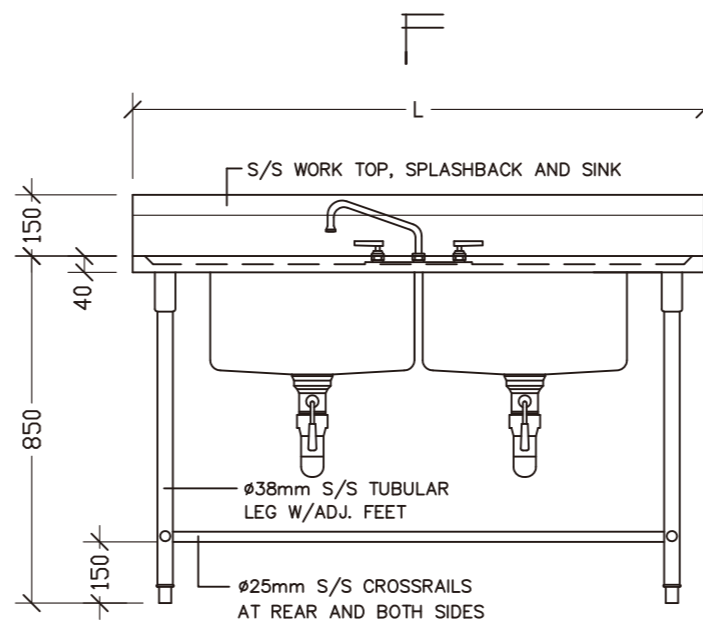

ELEVATION

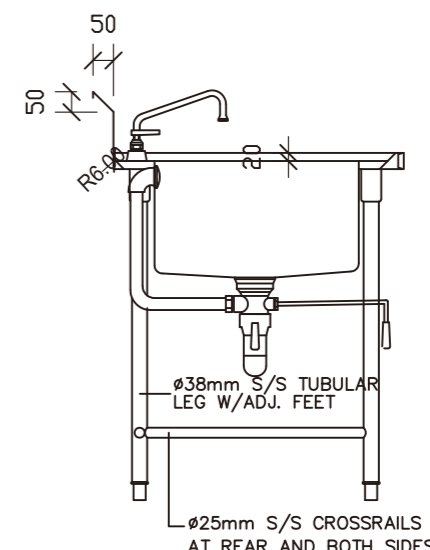

SECTION

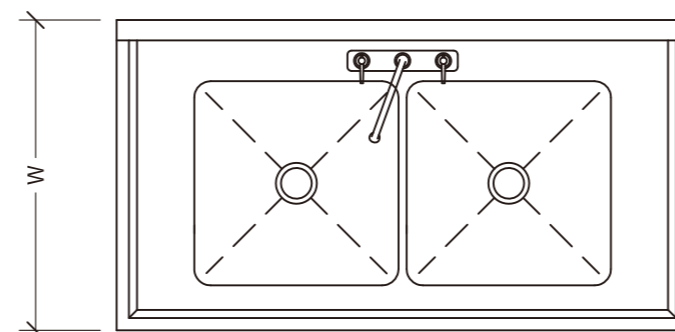

PLAN

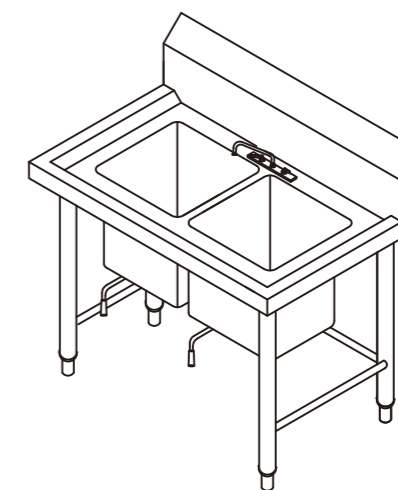

ISOMETRIC VIEW

技术说明:				SKU:			
1.所有产品边缘不能有毛刺, 覆膜面不能刮花;				名称:	建德C40+潜水俱乐部厨房		
2.公差要求标准: 符合GB/T G3280-2015不锈钢冷轧钢板和钢带标准中PT.A的公称宽度要求;				材料:			
3.所有标注尺寸为外尺寸;				编制:		日期:	
4.未注膜面方向朝外。				审核:		日期:	
A						视角:	
版本		批准	日期			版本:	A

STAINLESS STEEL SHOP DRAWING (CUSTOM)

不锈钢件生产要求图

Product Description (产品说明):	Work Table
	单层工作台
Model Type (模具型号):	TB L06

No:	Parts(零部件):	Material Specfication(用料标准):
✓ 01	COUNTER TOP 柜台面	16GA. THK. SUS 304 S/S
✓ 02	LEG 支腿	∅38mm 16 GA. THK. SUS 304 S/S TUBE
✓ 03	ADJUSTABLE FOOT INSERT 可调节嵌入式底脚	LUI CHUEN KEE (CHN)
✓ 04	REINFORCEMENT 加固件	16 GA. THK. SUS 304 S/S
05	SINK BOWL 洗碗槽	16 GA. THK. SUS 304 S/S
06	SINK WASTE 废料槽	
✓ 07	S.S. CROSS RAIL 横梁	∅32mm 16 GA. THK. SUS 304 S/S TUBE
08	WALL MOUNTED BRACKET 壁装托架	16 GA. THK. SUS 304 S/S
09	UNDER SHELF 底架	18 GA. THK. SUS 304 S/S
10	MIXING FAUCET 混合龙头	
11	OVER SHELF 顶架	18 GA. THK. SUS 304 S/S
12	OUTER DOOR PANEL 外板	20 GA. THK. SUS 304 S/S
13	INNER DOOR PANEL 内板	22 GA. THK. SUS 304 S/S
14	CABINET BODY 柜身	20 GA. THK. SUS 304 S/S
15	CORNER BUMPER 拐角防护套	COLSON (CHN)
16	SWIVEL CASTOR 旋转角轮	GLOBE (CHN)
17	SOUND DEADEN MATERIAL 隔音材料	3mm THICKNESS
18	WALL FLASHING 防水面	20 GA. THK. SUS 304 S/S
19	CONDENSING UNIT 制冷机组	DANFOSS (CHN)
20	NOZZLE 排气口	∅25mm SUS 304 S/S TUBE

No:	Item No(款号):	Qty(数量):	No:	Item No(款号):	Qty(数量):

Remark(备注):	
 M5	SPOT WELDED A THREADED SHAFT TO THE UNDERSIDE OF WORK TOP / SHELF. THEN USE UNITS TO FIX WITH THE REINFORCEMENT / BRACKETS

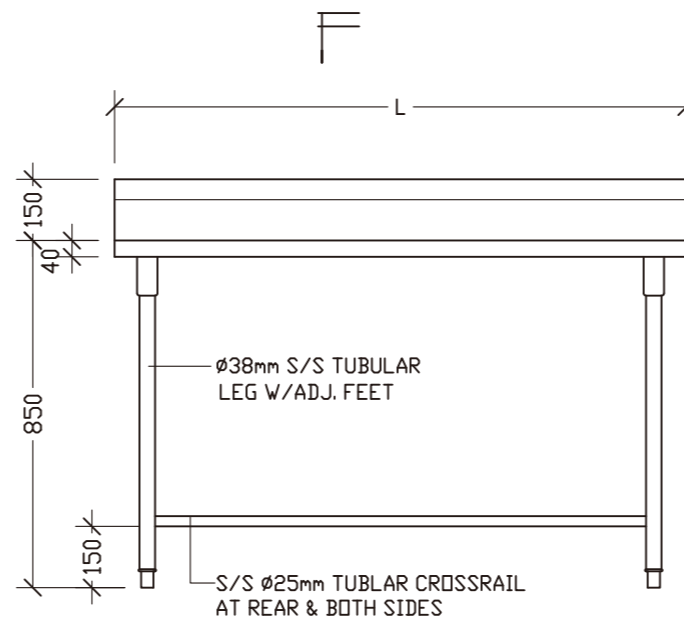

ELEVATION

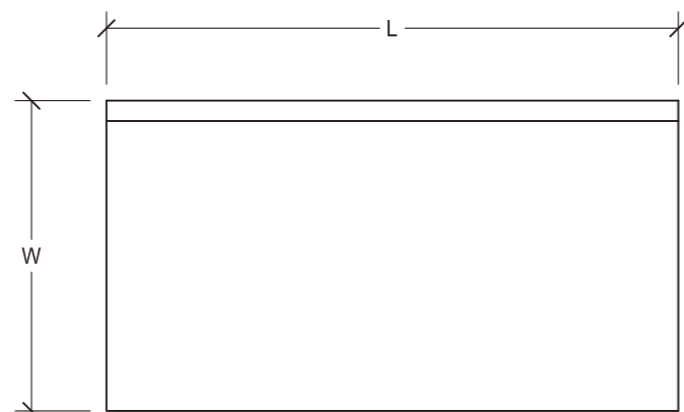

PLAN

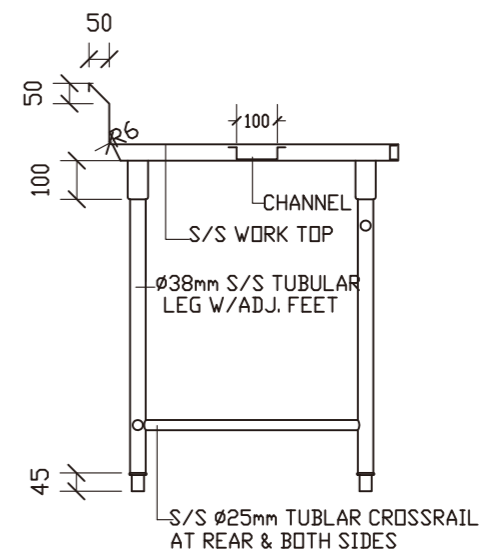

SECTION

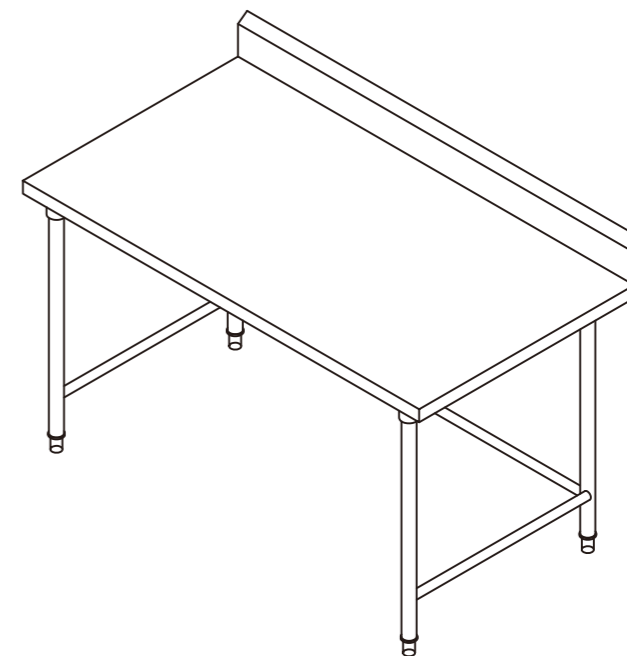

ISOMETRIC VIEW

技术说明:				SKU:			
1.所有产品边缘不能有毛刺, 覆膜面不能刮花;				名称:	建德C40+潜水俱乐部厨房		
2.公差要求标准: 符合GB/T G3280-2015不锈钢冷轧钢板和钢带标准中PT.A的公称宽度要求;				材料:			
3.所有标注尺寸为外尺寸;				编制:		日期:	
4.未注膜面方向朝外。				审核:		日期:	
A						视角:	
版本		批准	日期			版本:	A

STAINLESS STEEL SHOP DRAWING (CUSTOM)

不锈钢件生产要求图

Product Description (产品说明):	Double Ceiling Mounted Shelving
	吊天花双层架
Model Type (模具型号):	JBC2 L08

No:	Parts(零部件):	Material Specification(用料标准):
01	COUNTER TOP 柜台面	16GA. THK. SUS 304 S/S
✓ 02	LEG 支腿	∅38mm 16 GA. THK. SUS 304 S/S TUBE
03	ADJUSTABLE FOOT INSERT 可调节嵌入式底脚	LUI CHUEN KEE (CHN)
✓ 04	REINFORCEMENT 加固件	16 GA. THK. SUS 304 S/S
05	SINK BOWL 洗碗槽	16 GA. THK. SUS 304 S/S
06	SINK WASTE 废料槽	
07	S.S. CROSS RAIL 横梁	∅32mm 16 GA. THK. SUS 304 S/S TUBE
08	WALL MOUNTED BRACKET 壁装托架	16 GA. THK. SUS 304 S/S
09	UNDER SHELF 底架	18 GA. THK. SUS 304 S/S
10	MIXING FAUCET 混合龙头	
✓ 11	OVER SHELF 顶架	18 GA. THK. SUS 304 S/S
12	OUTER DOOR PANEL 外板	20 GA. THK. SUS 304 S/S
13	INNER DOOR PANEL 内板	22 GA. THK. SUS 304 S/S
14	CABINET BODY 柜身	20 GA. THK. SUS 304 S/S
15	CORNER BUMPER 拐角防护套	COLSON (CHN)
16	SWIVEL CASTOR 旋转角轮	GLOBE (CHN)
17	SOUND DEADEN MATERIAL 隔音材料	3mm THICKNESS
18	WALL FLASHING 防水面	20 GA. THK. SUS 304 S/S
19	CONDENSING UNIT 制冷机组	DANFOSS (CHN)
20	NOZZLE 排气口	∅25mm SUS 304 S/S TUBE

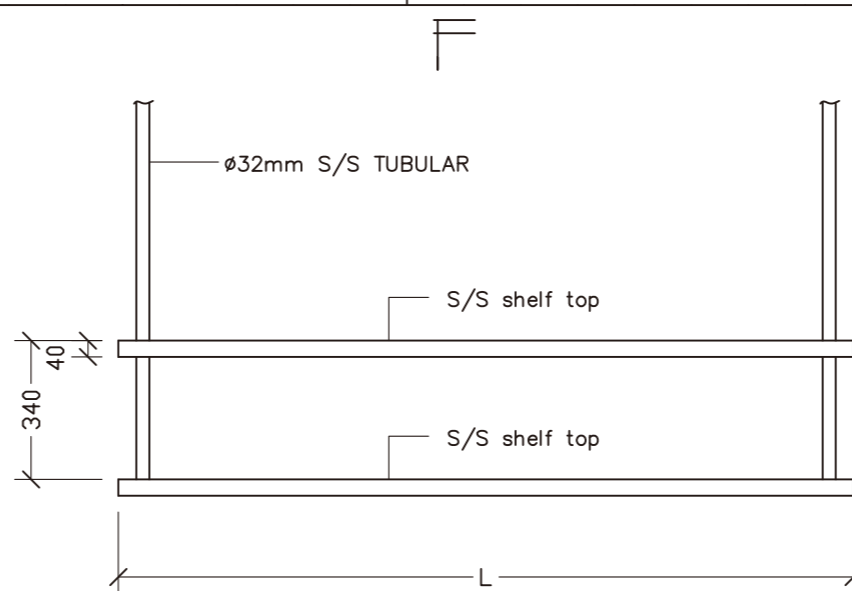

ELEVATION

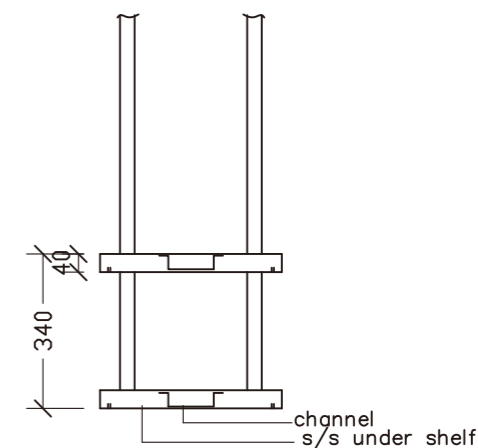

SECTION

No:	Item No(款号):	Qty(数量):	No:	Item No(款号):	Qty(数量):

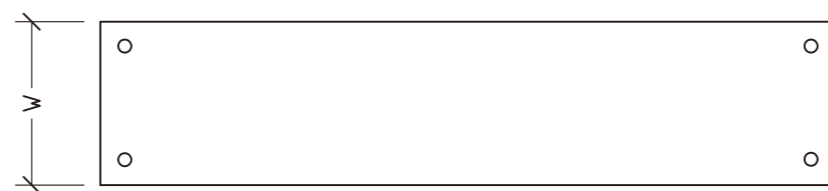

PLAN

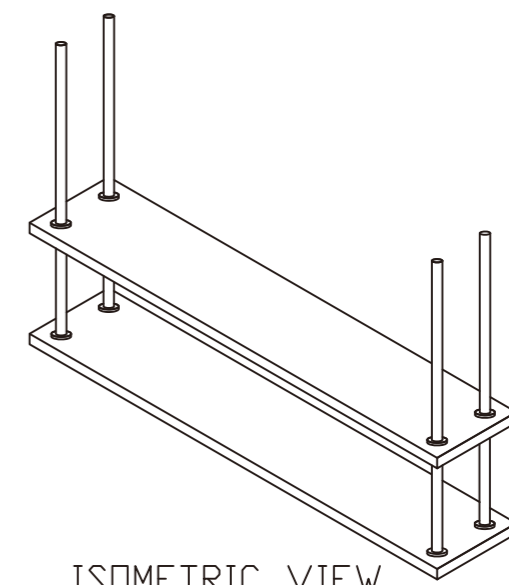

ISOMETRIC VIEW

Remark(备注):



SPOT WELDED A THREADED SHAFT TO THE UNDERSIDE OF WORK TOP / SHELF. THEN USE UNITS TO FIX WITH THE REINFORCEMENT / BRACKETS

技术说明:				SKU:			
1.所有产品边缘不能有毛刺, 覆膜面不能刮花;				名称:	建德C40+潜水俱乐部厨房		
2.公差要求标准: 符合GB/T G3280-2015不锈钢冷轧钢板和钢带标准中PT.A的公称宽度要求;				材料:			
3.所有标注尺寸为外尺寸;				编制:		日期:	
4.未注膜面方向朝外。				审核:		日期:	
A						视角:	☉
版本		批准	日期			版本:	A

STAINLESS STEEL SHOP DRAWING (CUSTOM)

不锈钢件生产要求图

Product Description (产品说明):	Dish Landing Table W/Double Sinks
	双星污碟台
Model Type (模具型号):	TDLSH2 M02

No:	Parts(零部件):	Material Specification(用料标准):
✓ 01	COUNTER TOP 柜台面	16GA. THK. SUS 304 S/S
✓ 02	LEG 支腿	∅38mm 16 GA. THK. SUS 304 S/S TUBE
✓ 03	ADJUSTABLE FOOT INSERT 可调节嵌入式底脚	LUI CHUEN KEE (CHN)
✓ 04	REINFORCEMENT 加固件	16 GA. THK. SUS 304 S/S
✓ 05	SINK BOWL 洗碗槽	16 GA. THK. SUS 304 S/S
06	SINK WASTE 废料槽	
✓ 07	S.S. CROSS RAIL 横梁	∅32mm 16 GA. THK. SUS 304 S/S TUBE
08	WALL MOUNTED BRACKET 壁装托架	16 GA. THK. SUS 304 S/S
09	UNDER SHELF 底架	18 GA. THK. SUS 304 S/S
✓ 10	MIXING FAUCET 混合龙头	
11	OVER SHELF 顶架	18 GA. THK. SUS 304 S/S
12	OUTER DOOR PANEL 外板	20 GA. THK. SUS 304 S/S
13	INNER DOOR PANEL 内板	22 GA. THK. SUS 304 S/S
14	CABINET BODY 柜身	20 GA. THK. SUS 304 S/S
15	CORNER BUMPER 拐角防护套	COLSON (CHN)
16	SWIVEL CASTOR 旋转角轮	GLOBE (CHN)
17	SOUND DEADEN MATERIAL 隔音材料	3mm THICKNESS
18	WALL FLASHING 防水面	20 GA. THK. SUS 304 S/S
19	CONDENSING UNIT 制冷机组	DANFOSS (CHN)
20	NOZZLE 排气口	∅25mm SUS 304 S/S TUBE

No:	Item No(款号):	Qty(数量):	No:	Item No(款号):	Qty(数量):

Remark(备注):

 M5

SPOT WELDED A THREADED SHAFT TO THE UNDERSIDE OF WORK TOP / SHELF. THEN USE UNITS TO FIX WITH THE REINFORCEMENT / BRACKETS

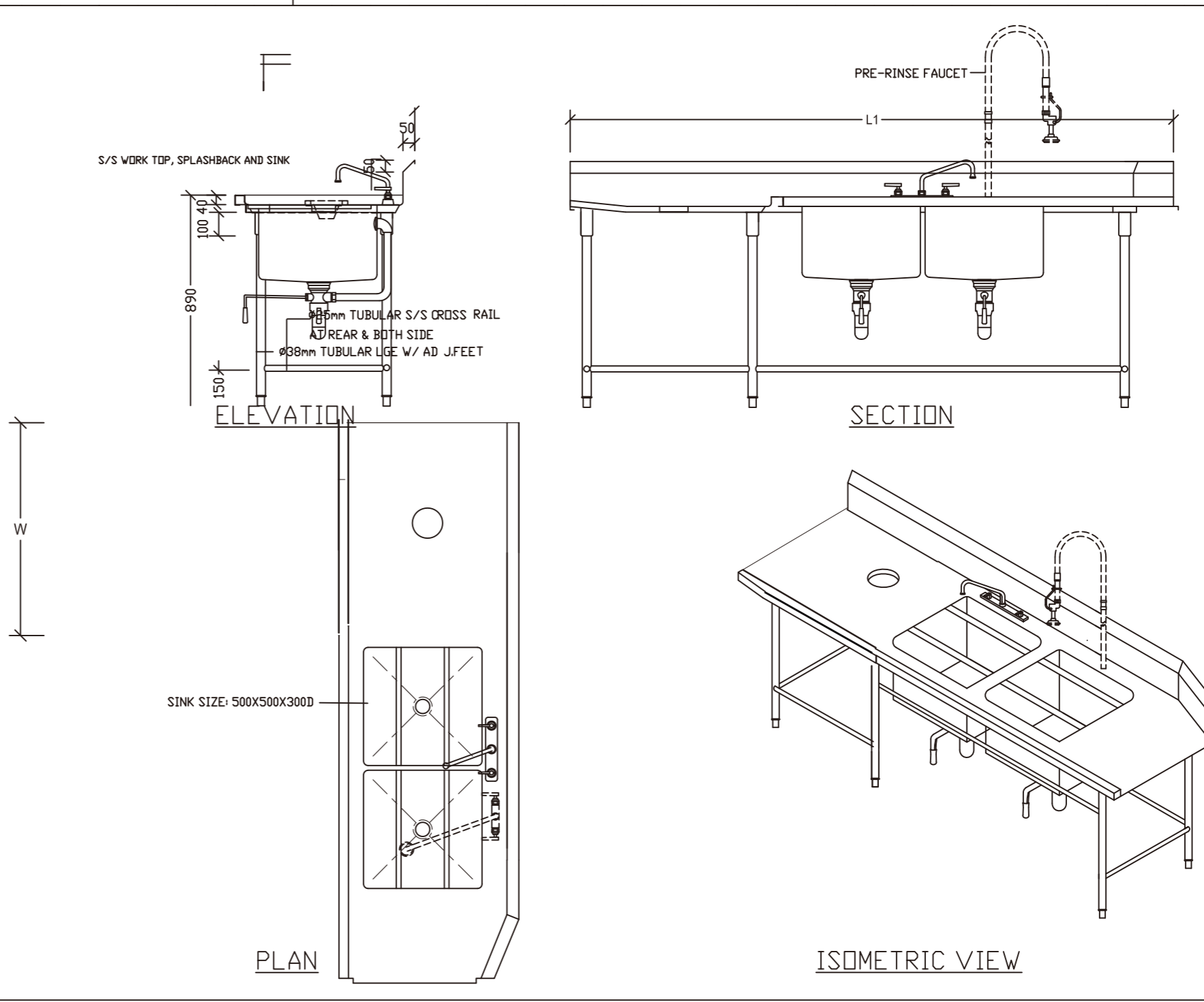

技术说明:				SKU:			
1.所有产品边缘不能有毛刺, 覆膜面不能刮花;				名称:	建德C40+潜水俱乐部厨房		
2.公差要求标准: 符合GB/T G3280-2015不锈钢冷轧钢板和钢带标准中PT.A的公称宽度要求;				材料:			
3.所有标注尺寸为外尺寸;				编制:		日期:	
4.未注膜面方向朝外。				审核:		日期:	
A						视角:	
版本		批准	日期			版本:	A

STAINLESS STEEL SHOP DRAWING (CUSTOM)

不锈钢件生产要求图

Product Description (产品说明):	Ceiling Mounted Dish Rack
	挂墙茜架
Model Type (模具型号):	JCWB M03

No:	Parts(零部件):	Material Specfication(用料标准):
01	COUNTER TOP 柜台面	16GA. THK. SUS 304 S/S
02	LEG 支腿	∅38mm 16 GA. THK. SUS 304 S/S TUBE
03	ADJUSTABLE FOOT INSERT 可调节嵌入式底脚	LUI CHUEN KEE (CHN)
✓ 04	REINFORCEMENT 加固件	16 GA. THK. SUS 304 S/S
05	SINK BOWL 洗碗槽	16 GA. THK. SUS 304 S/S
06	SINK WASTE 废料槽	
07	S.S. CROSS RAIL 横梁	∅32mm 16 GA. THK. SUS 304 S/S TUBE
08	WALL MOUNTED BRACKET 壁装托架	16 GA. THK. SUS 304 S/S
09	UNDER SHELF 底架	18 GA. THK. SUS 304 S/S
10	MIXING FAUCET 混合龙头	
✓ 11	OVER SHELF 顶架	18 GA. THK. SUS 304 S/S
12	OUTER DOOR PANEL 外板	20 GA. THK. SUS 304 S/S
13	INNER DOOR PANEL 内板	22 GA. THK. SUS 304 S/S
14	CABINET BODY 柜身	20 GA. THK. SUS 304 S/S
15	CORNER BUMPER 拐角防护套	COLSON (CHN)
16	SWIVEL CASTOR 旋转角轮	GLOBE (CHN)
17	SOUND DEADEN MATERIAL 隔音材料	3mm THICKNESS
18	WALL FLASHING 防水面	20 GA. THK. SUS 304 S/S
19	CONDENSING UNIT 制冷机组	DANFOSS (CHN)
20	NOZZLE 排气口	∅25mm SUS 304 S/S TUBE

No:	Item No(款号):	Qty(数量):	No:	Item No(款号):	Qty(数量):

Remark(备注):



SPOT WELDED A THREADED SHAFT TO THE UNDERSIDE OF WORK TOP / SHELF. THEN USE UNITS TO FIX WITH THE REINFORCEMENT / BRACKETS

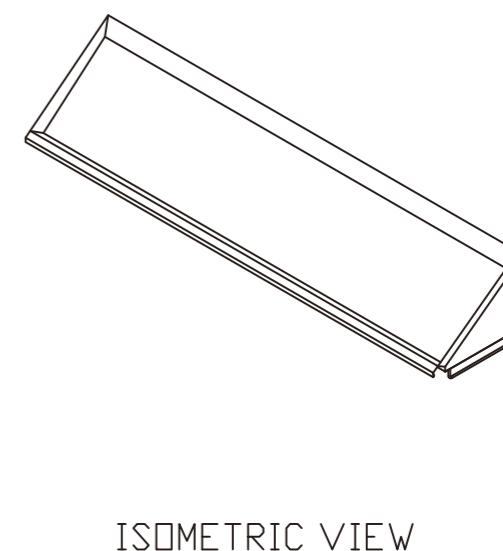
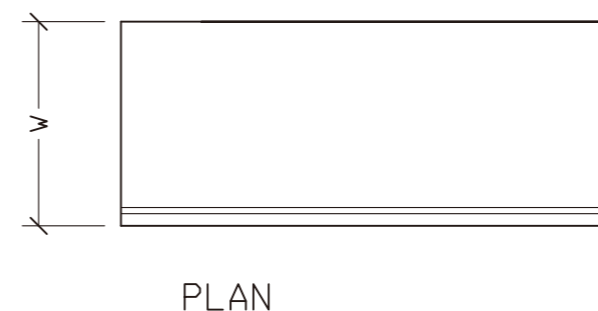
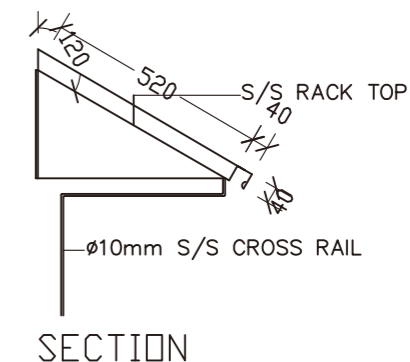
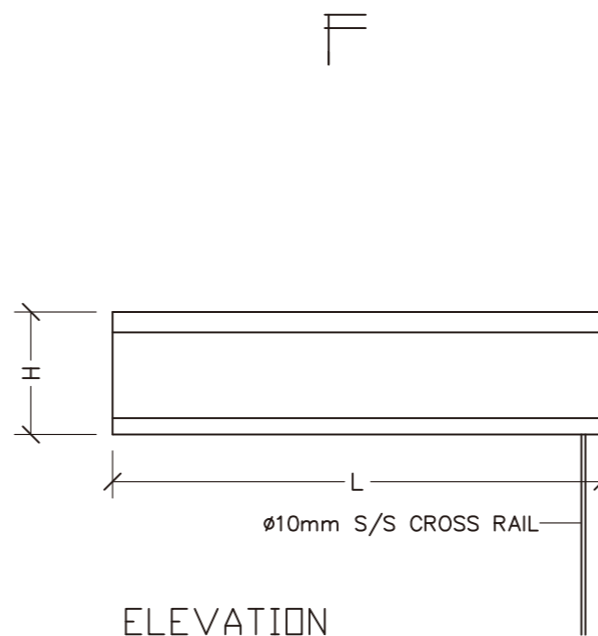

技术说明:				SKU:			
1.所有产品边缘不能有毛刺, 覆膜面不能刮花;				名称:	建德C40+潜水俱乐部厨房		
2.公差要求标准: 符合GB/T G3280-2015不锈钢冷轧钢板和钢带标准中PT.A的公称宽度要求;				材料:			
3.所有标注尺寸为外尺寸;				编制:		日期:	
4.未注膜面方向朝外。				审核:		日期:	
A						视角:	☉ ☒
版本		批准	日期			版本:	A

STAINLESS STEEL SHOP DRAWING (CUSTOM)

不锈钢件生产要求图

Product Description (产品说明):	Clean Dish Landing Table
	洁碟台
Model Type (模具型号):	TCL M04

No:	Parts(零部件):	Material Specification(用料标准):
✓ 01	COUNTER TOP 柜台面	16GA. THK. SUS 304 S/S
✓ 02	LEG 支腿	Ø38mm 16 GA. THK. SUS 304 S/S TUBE
✓ 03	ADJUSTABLE FOOT INSERT 可调节嵌入式底脚	LUI CHUEN KEE (CHN)
✓ 04	REINFORCEMENT 加固件	16 GA. THK. SUS 304 S/S
05	SINK BOWL 洗碗槽	16 GA. THK. SUS 304 S/S
06	SINK WASTE 废料槽	
✓ 07	S.S. CROSS RAIL 横梁	Ø32mm 16 GA. THK. SUS 304 S/S TUBE
✓ 08	WALL MOUNTED BRACKET 壁装托架	16 GA. THK. SUS 304 S/S
09	UNDER SHELF 底架	18 GA. THK. SUS 304 S/S
10	MIXING FAUCET 混合龙头	
11	OVER SHELF 顶架	18 GA. THK. SUS 304 S/S
12	OUTER DOOR PANEL 外板	20 GA. THK. SUS 304 S/S
13	INNER DOOR PANEL 内板	22 GA. THK. SUS 304 S/S
14	CABINET BODY 柜身	20 GA. THK. SUS 304 S/S
15	CORNER BUMPER 拐角防护套	COLSON (CHN)
16	SWIVEL CASTOR 旋转角轮	GLOBE (CHN)
17	SOUND DEADEN MATERIAL 隔音材料	3mm THICKNESS
18	WALL FLASHING 防水面	20 GA. THK. SUS 304 S/S
19	CONDENSING UNIT 制冷机组	DANFOSS (CHN)
20	NOZZLE 排气口	Ø25mm SUS 304 S/S TUBE

No:	Item No(款号):	Qty(数量):	No:	Item No(款号):	Qty(数量):

Remark(备注):



SPOT WELDED A THREADED SHAFT TO THE UNDERSIDE OF WORK TOP / SHELF. THEN USE UNITS TO FIX WITH THE REINFORCEMENT / BRACKETS

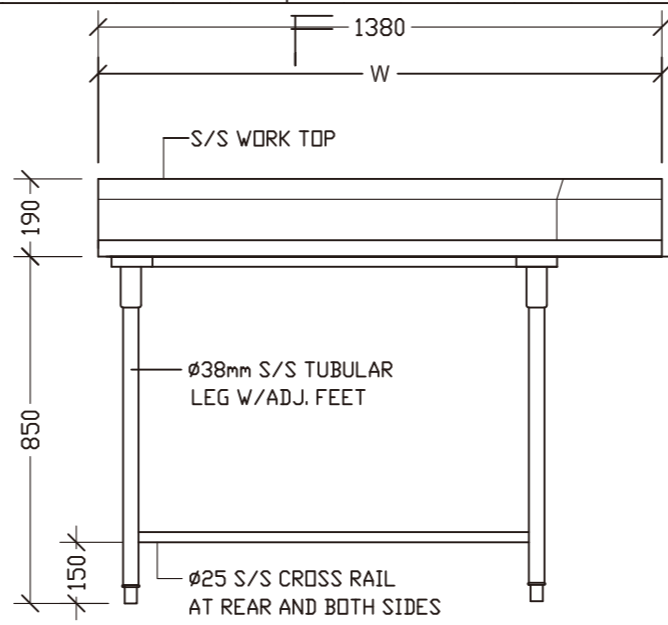

ELEVATION

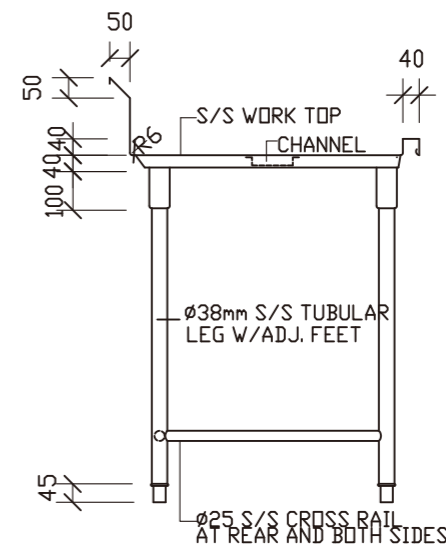

SECTION

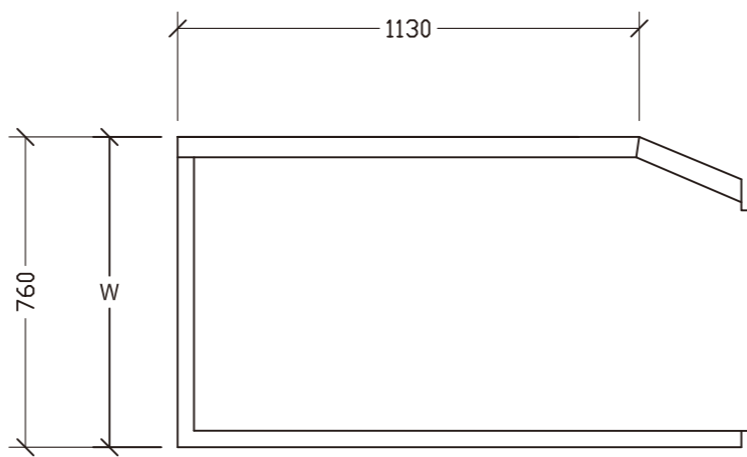

PLAN

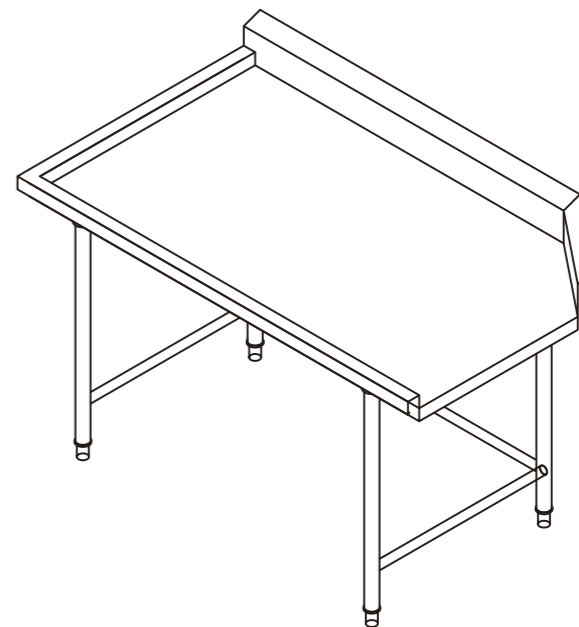

ISOMETRIC VIEW

技术说明:
 1.所有产品边缘不能有毛刺, 覆膜面不能刮花;
 2.公差要求标准: 符合GB/T G3280-2015不锈钢冷轧钢板和钢带标准中PT.A的公称宽度要求;
 3.所有标注尺寸为外尺寸;
 4.未注膜面方向朝外。

SKU:		日期:		视角:	☉
名称:	建德C40+潜水俱乐部厨房	日期:		版本:	A
材料:					
编制:					
审核:					

A					
版本			批准	日期	

STAINLESS STEEL SHOP DRAWING (CUSTOM)

不锈钢件生产要求图

Product Description (产品说明):	Single Wall Mounted Shelving
	单层挂墙层架
Model Type (模具型号):	JBW1 M05

No:	Parts(零部件):	Material Specification(用料标准):
01	COUNTER TOP 柜台面	16GA. THK. SUS 304 S/S
02	LEG 支腿	∅38mm 16 GA. THK. SUS 304 S/S TUBE
03	ADJUSTABLE FOOT INSERT 可调节嵌入式底脚	LUI CHUEN KEE (CHN)
✓ 04	REINFORCEMENT 加固件	16 GA. THK. SUS 304 S/S
05	SINK BOWL 洗碗槽	16 GA. THK. SUS 304 S/S
06	SINK WASTE 废料槽	
07	S.S. CROSS RAIL 横梁	∅32mm 16 GA. THK. SUS 304 S/S TUBE
✓ 08	WALL MOUNTED BRACKET 壁装托架	16 GA. THK. SUS 304 S/S
09	UNDER SHELF 底架	18 GA. THK. SUS 304 S/S
10	MIXING FAUCET 混合龙头	
✓ 11	OVER SHELF 顶架	18 GA. THK. SUS 304 S/S
12	OUTER DOOR PANEL 外板	20 GA. THK. SUS 304 S/S
13	INNER DOOR PANEL 内板	22 GA. THK. SUS 304 S/S
14	CABINET BODY 柜身	20 GA. THK. SUS 304 S/S
15	CORNER BUMPER 拐角防护套	COLSON (CHN)
16	SWIVEL CASTOR 旋转角轮	GLOBE (CHN)
17	SOUND DEADEN MATERIAL 隔音材料	3mm THICKNESS
18	WALL FLASHING 防水面	20 GA. THK. SUS 304 S/S
19	CONDENSING UNIT 制冷机组	DANFOSS (CHN)
20	NOZZLE 排气口	∅25mm SUS 304 S/S TUBE

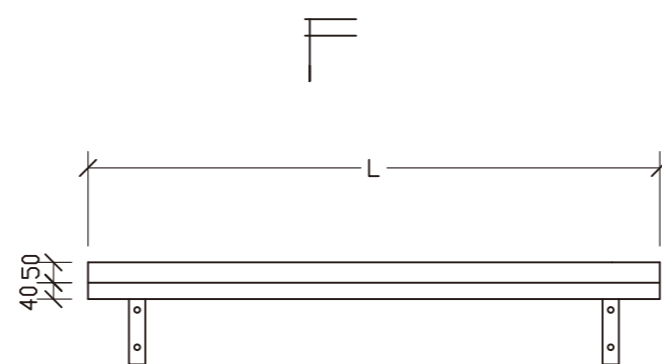

ELEVATION

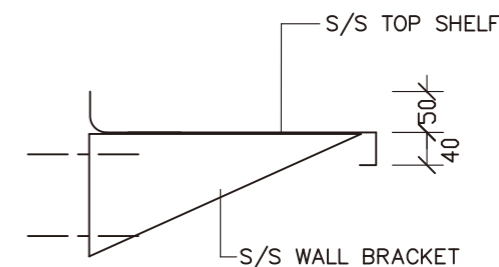

SECTION

No:	Item No(款号):	Qty(数量):	No:	Item No(款号):	Qty(数量):

Remark(备注):



SPOT WELDED A THREADED SHAFT TO THE UNDERSIDE OF WORK TOP / SHELF. THEN USE UNITS TO FIX WITH THE REINFORCEMENT / BRACKETS

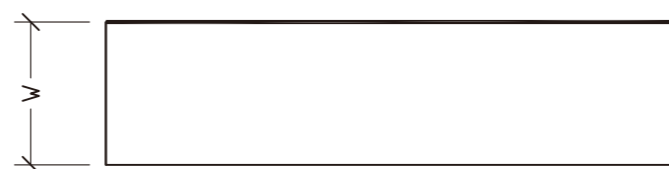

PLAN

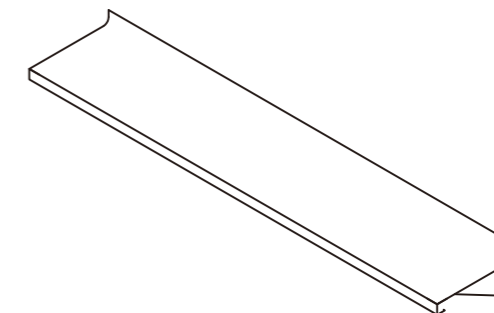

ISOMETRIC VIEW

技术说明:				SKU:			
1.所有产品边缘不能有毛刺, 覆膜面不能刮花;				名称:	建德C40+潜水俱乐部厨房		
2.公差要求标准: 符合GB/T G3280-2015不锈钢冷轧钢板和钢带标准中PT.A的公称宽度要求;				材料:			
3.所有标注尺寸为外尺寸;				编制:		日期:	
4.未注膜面方向朝外。				审核:		日期:	
A						视角:	☉
版本		批准	日期			版本:	A

STAINLESS STEEL SHOP DRAWING (CUSTOM)

不锈钢件生产要求图

Product Description (产品说明):	Uright Storage Cabinet
	高身储物柜
Model Type (模具型号):	CUS M06

No:	Parts(零部件):	Material Specfication(用料标准):
✓ 01	COUNTER TOP 柜台面	16GA. THK. SUS 304 S/S
02	LEG 支腿	∅38mm 16 GA. THK. SUS 304 S/S TUBE
✓ 03	ADJUSTABLE FOOT INSERT 可调节嵌入式底脚	LUI CHUEN KEE (CHN)
✓ 04	REINFORCEMENT 加固件	16 GA. THK. SUS 304 S/S
05	SINK BOWL 洗碗槽	16 GA. THK. SUS 304 S/S
06	SINK WASTE 废料槽	
07	S.S. CROSS RAIL 横梁	∅32mm 16 GA. THK. SUS 304 S/S TUBE
08	WALL MOUNTED BRACKET 壁装托架	16 GA. THK. SUS 304 S/S
✓ 09	UNDER SHELF 底架	18 GA. THK. SUS 304 S/S
10	MIXING FAUCET 混合龙头	
11	OVER SHELF 顶架	18 GA. THK. SUS 304 S/S
✓ 12	OUTER DOOR PANEL 外板	20 GA. THK. SUS 304 S/S
✓ 13	INNER DOOR PANEL 内板	22 GA. THK. SUS 304 S/S
✓ 14	CABINET BODY 柜身	20 GA. THK. SUS 304 S/S
15	CORNER BUMPER 拐角防护套	COLSON (CHN)
16	SWIVEL CASTOR 旋转角轮	GLOBE (CHN)
17	SOUND DEADEN MATERIAL 隔音材料	3mm THICKNESS
18	WALL FLASHING 防水面	20 GA. THK. SUS 304 S/S
19	CONDENSING UNIT 制冷机组	DANFOSS (CHN)
20	NOZZLE 排气口	∅25mm SUS 304 S/S TUBE

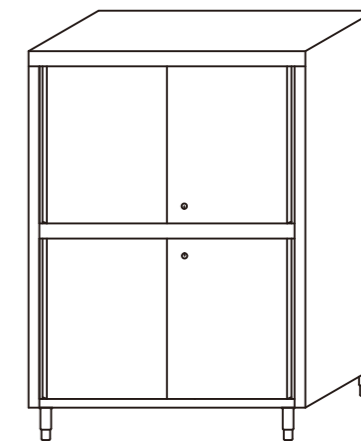
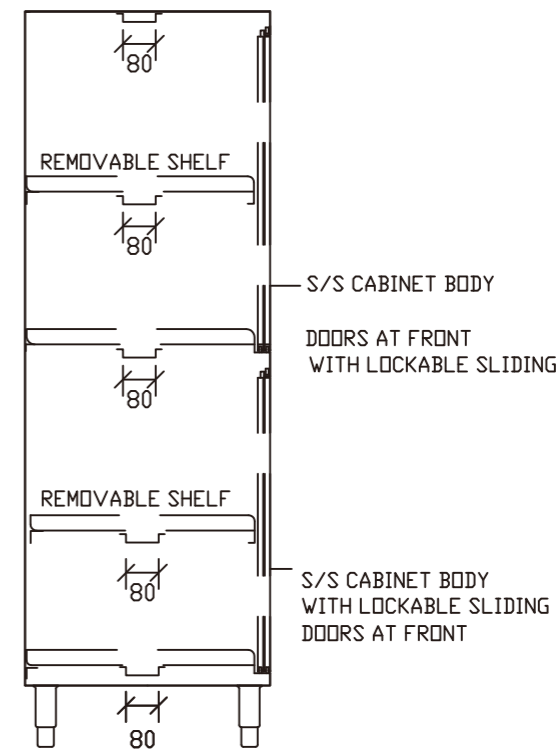
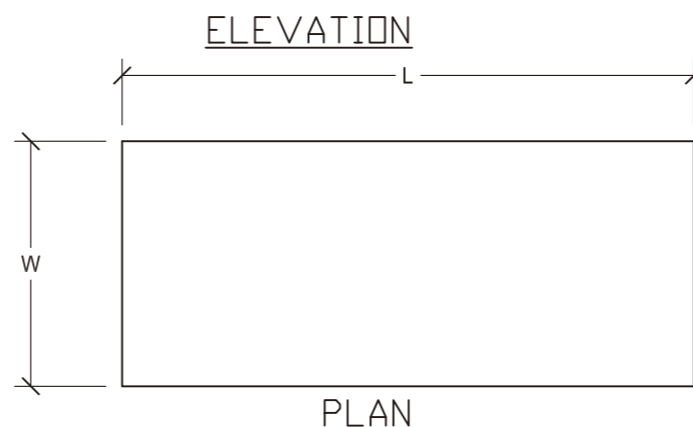
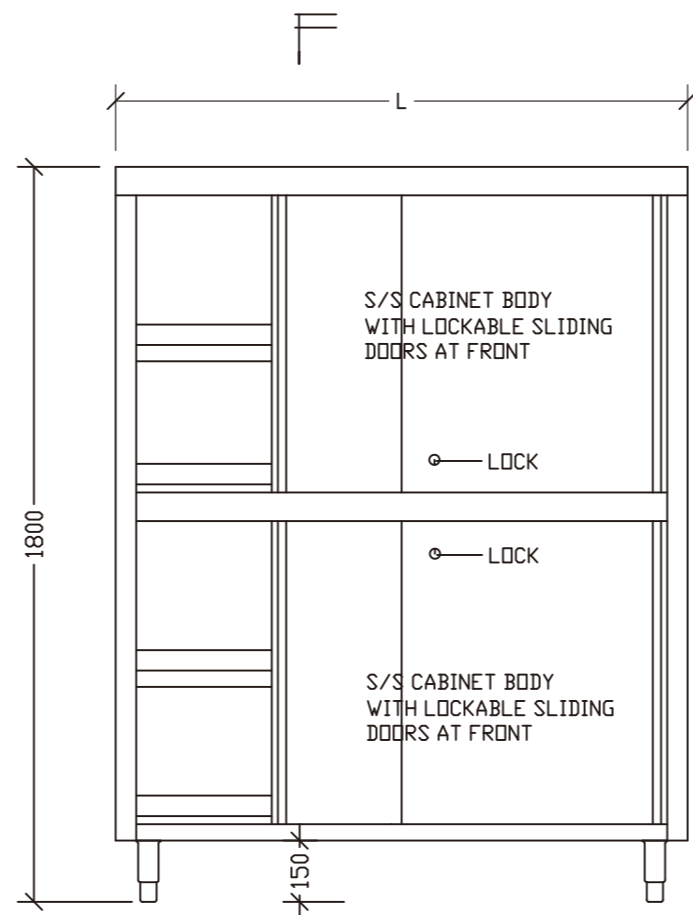

No:	Item No(款号):	Qty(数量):	No:	Item No(款号):	Qty(数量):

Remark(备注):



SPOT WELDED A THREADED SHAFT TO THE UNDERSIDE OF WORK TOP / SHELF. THEN USE UNITS TO FIX WITH THE REINFORCEMENT / BRACKETS

技术说明:				SKU:			
1.所有产品边缘不能有毛刺, 覆膜面不能刮花;				名称:	建德C40+潜水俱乐部厨房		
2.公差要求标准: 符合GB/T G3280-2015不锈钢冷轧钢板和钢带标准中PT.A的公称宽度要求;				材料:			
3.所有标注尺寸为外尺寸;				编制:		日期:	
4.未注膜面方向朝外。				审核:		日期:	
A						视角:	
版本		批准	日期			版本:	A

STAINLESS STEEL SHOP DRAWING (CUSTOM)

不锈钢件生产要求图

Product Description (产品说明):	Cabinet W/Single Sink & Waste Bin
	单星盆柜连垃圾筒柜
Model Type (模具型号):	SBSH115 N03

No:	Parts(零部件):	Material Specification(用料标准):
✓ 01	COUNTER TOP 柜台面	16GA. THK. SUS 304 S/S
02	LEG 支腿	∅38mm 16 GA. THK. SUS 304 S/S TUBE
✓ 03	ADJUSTABLE FOOT INSERT 可调节嵌入式底脚	LUI CHUEN KEE (CHN)
✓ 04	REINFORCEMENT 加固件	16 GA. THK. SUS 304 S/S
05	SINK BOWL 洗碗槽	16 GA. THK. SUS 304 S/S
✓ 06	SINK WASTE 废料槽	
07	S.S. CROSS RAIL 横梁	∅32mm 16 GA. THK. SUS 304 S/S TUBE
08	WALL MOUNTED BRACKET 壁装托架	16 GA. THK. SUS 304 S/S
09	UNDER SHELF 底架	18 GA. THK. SUS 304 S/S
10	MIXING FAUCET 混合龙头	
11	OVER SHELF 顶架	18 GA. THK. SUS 304 S/S
✓ 12	OUTER DOOR PANEL 外板	20 GA. THK. SUS 304 S/S
✓ 13	INNER DOOR PANEL 内板	22 GA. THK. SUS 304 S/S
✓ 14	CABINET BODY 柜身	20 GA. THK. SUS 304 S/S
15	CORNER BUMPER 拐角防护套	COLSON (CHN)
16	SWIVEL CASTOR 旋转角轮	GLOBE (CHN)
17	SOUND DEADEN MATERIAL 隔音材料	3mm THICKNESS
18	WALL FLASHING 防水面	20 GA. THK. SUS 304 S/S
19	CONDENSING UNIT 制冷机组	DANFOSS (CHN)
20	NOZZLE 排气口	∅25mm SUS 304 S/S TUBE

No:	Item No(款号):	Qty(数量):	No:	Item No(款号):	Qty(数量):

Remark(备注):



SPOT WELDED A THREADED SHAFT TO THE UNDERSIDE OF WORK TOP / SHELF. THEN USE UNITS TO FIX WITH THE REINFORCEMENT / BRACKETS

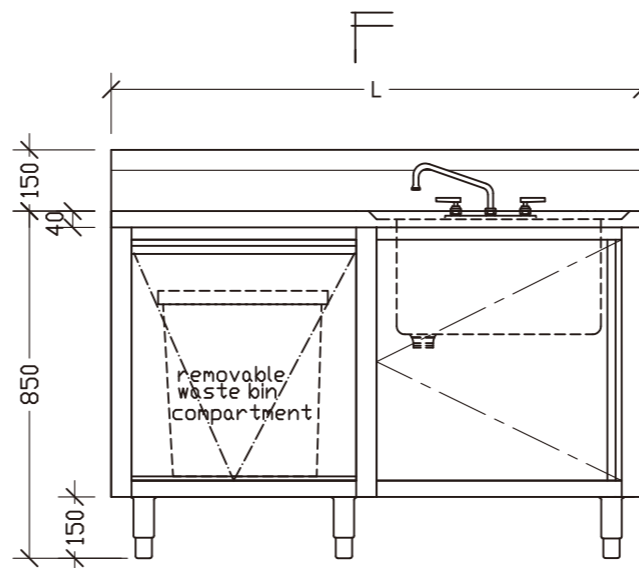

ELEVATION

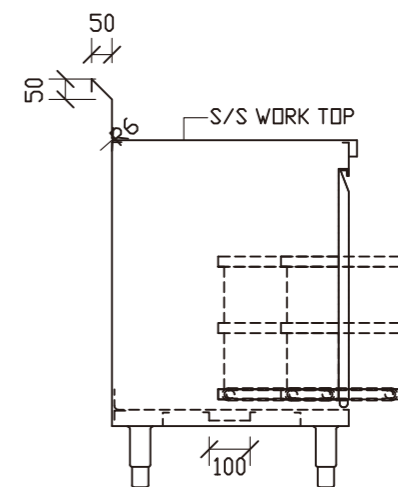

SECTION

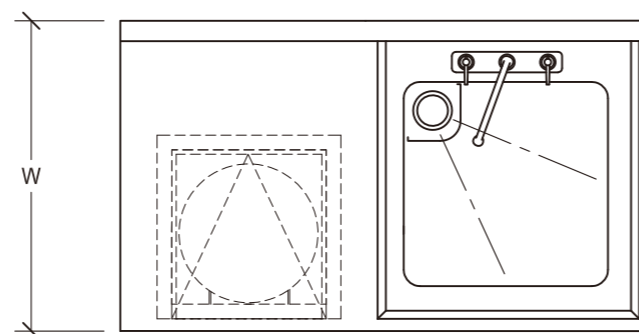

PLAN

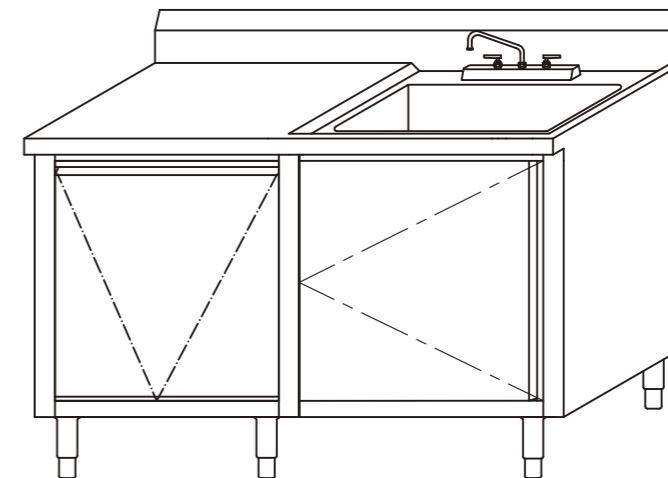

ISOMETRIC VIEW

技术说明:				SKU:			
1.所有产品边缘不能有毛刺, 覆膜面不能刮花;				名称:	建德C40+潜水俱乐部厨房		
2.公差要求标准: 符合GB/T G3280-2015不锈钢冷轧钢板和钢带标准中PT.A的公称宽度要求;				材料:			
3.所有标注尺寸为外尺寸;				编制:		日期:	
4.未注膜面方向朝外。				审核:		日期:	
A						视角:	☉ ☒
版本			批准	日期		版本:	A

STAINLESS STEEL SHOP DRAWING (CUSTOM)

不锈钢件生产要求图

Product Description (产品说明):	Work Cabinet
	工作掩门柜
Model Type (模具型号):	CBH N04

No:	Parts(零部件):	Material Specification(用料标准):
✓ 01	COUNTER TOP 柜台面	16GA. THK. SUS 304 S/S
02	LEG 支腿	Ø38mm 16 GA. THK. SUS 304 S/S TUBE
✓ 03	ADJUSTABLE FOOT INSERT 可调节嵌入式底脚	LUI CHUEN KEE (CHN)
✓ 04	REINFORCEMENT 加固件	16 GA. THK. SUS 304 S/S
05	SINK BOWL 洗碗槽	16 GA. THK. SUS 304 S/S
06	SINK WASTE 废料槽	
07	S.S. CROSS RAIL 横梁	Ø32mm 16 GA. THK. SUS 304 S/S TUBE
08	WALL MOUNTED BRACKET 壁装托架	16 GA. THK. SUS 304 S/S
✓ 09	UNDER SHELF 底架	18 GA. THK. SUS 304 S/S
10	MIXING FAUCET 混合龙头	
11	OVER SHELF 顶架	18 GA. THK. SUS 304 S/S
✓ 12	OUTER DOOR PANEL 外板	20 GA. THK. SUS 304 S/S
✓ 13	INNER DOOR PANEL 内板	22 GA. THK. SUS 304 S/S
✓ 14	CABINET BODY 柜身	20 GA. THK. SUS 304 S/S
15	CORNER BUMPER 拐角防护套	COLSON (CHN)
16	SWIVEL CASTOR 旋转角轮	GLOBE (CHN)
17	SOUND DEADEN MATERIAL 隔音材料	3mm THICKNESS
18	WALL FLASHING 防水面	20 GA. THK. SUS 304 S/S
19	CONDENSING UNIT 制冷机组	DANFOSS (CHN)
20	NOZZLE 排气口	Ø25mm SUS 304 S/S TUBE

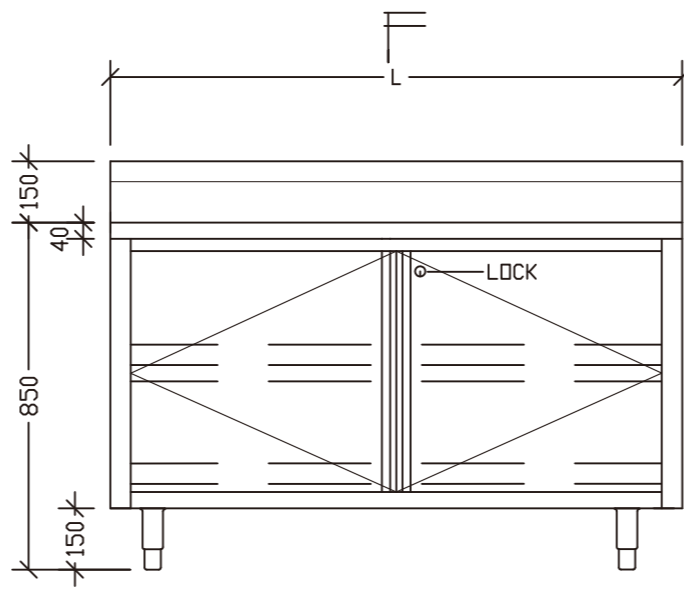

ELEVATION

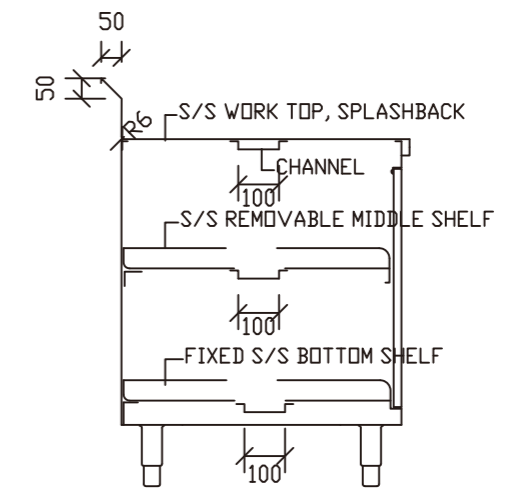

SECTION

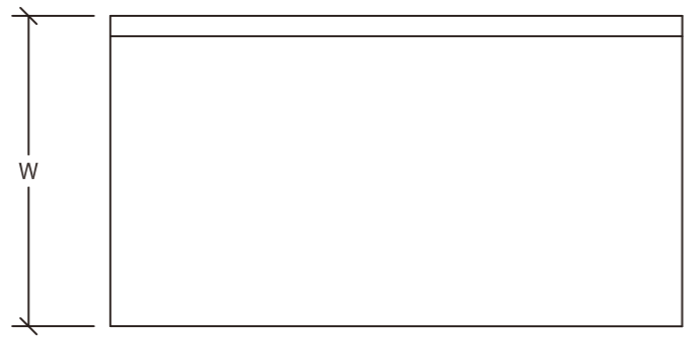

PLAN

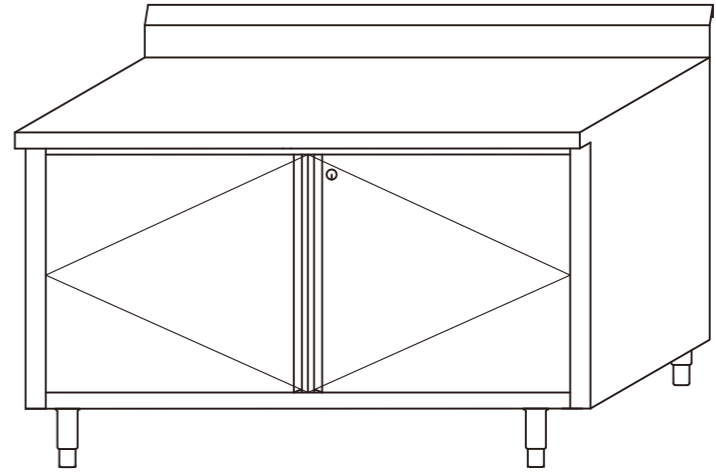

ISOMETRIC VIEW

No:	Item No(款号):	Qty(数量):	No:	Item No(款号):	Qty(数量):

Remark(备注):



SPOT WELDED A THREADED SHAFT TO THE UNDERSIDE OF WORK TOP / SHELF. THEN USE UNITS TO FIX WITH THE REINFORCEMENT / BRACKETS

技术说明:				SKU:			
1.所有产品边缘不能有毛刺, 覆膜面不能刮花;				名称:	建德C40+潜水俱乐部厨房		
2.公差要求标准: 符合GB/T G3280-2015不锈钢冷轧钢板和钢带标准中PT.A的公称宽度要求;				材料:			
3.所有标注尺寸为外尺寸;				编制:		日期:	
4.未注膜面方向朝外。				审核:		日期:	
A						视角:	☉
版本			批准	日期		版本:	A

STAINLESS STEEL SHOP DRAWING (CUSTOM)

不锈钢件生产要求图

Product Description (产品说明):	Work Table W/Under Shelf
	工作台下置层板
Model Type (模具型号):	TBS1 N05

No:	Parts(零部件):	Material Specification(用料标准):
✓ 01	COUNTER TOP 柜台面	16GA. THK. SUS 304 S/S
✓ 02	LEG 支腿	Ø38mm 16 GA. THK. SUS 304 S/S TUBE
✓ 03	ADJUSTABLE FOOT INSERT 可调节嵌入式底脚	LUI CHUEN KEE (CHN)
✓ 04	REINFORCEMENT 加固件	16 GA. THK. SUS 304 S/S
05	SINK BOWL 洗碗槽	16 GA. THK. SUS 304 S/S
06	SINK WASTE 废料槽	
✓ 07	S.S. CROSS RAIL 横梁	Ø32mm 16 GA. THK. SUS 304 S/S TUBE
08	WALL MOUNTED BRACKET 壁挂托架	16 GA. THK. SUS 304 S/S
09	UNDER SHELF 底架	18 GA. THK. SUS 304 S/S
10	MIXING FAUCET 混合龙头	
11	OVER SHELF 顶架	18 GA. THK. SUS 304 S/S
12	OUTER DOOR PANEL 外板	20 GA. THK. SUS 304 S/S
13	INNER DOOR PANEL 内板	22 GA. THK. SUS 304 S/S
14	CABINET BODY 柜身	20 GA. THK. SUS 304 S/S
15	CORNER BUMPER 拐角防护套	COLSON (CHN)
16	SWIVEL CASTOR 旋转角轮	GLOBE (CHN)
17	SOUND DEADEN MATERIAL 隔音材料	3mm THICKNESS
18	WALL FLASHING 防水面	20 GA. THK. SUS 304 S/S
19	CONDENSING UNIT 制冷机组	DANFOSS (CHN)
20	NOZZLE 排气口	Ø25mm SUS 304 S/S TUBE

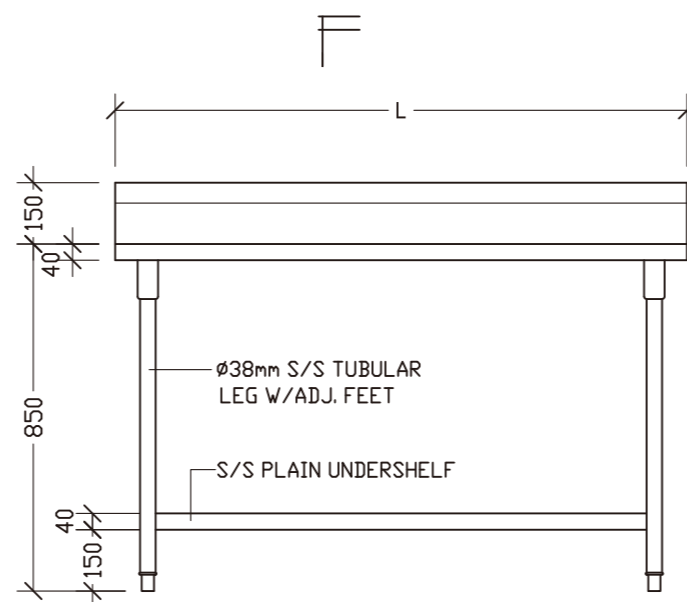

ELEVATION

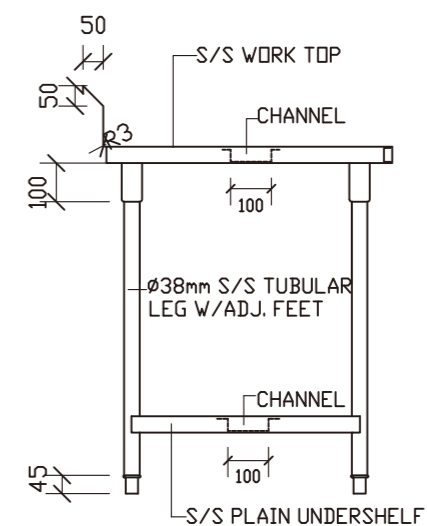

SECTION

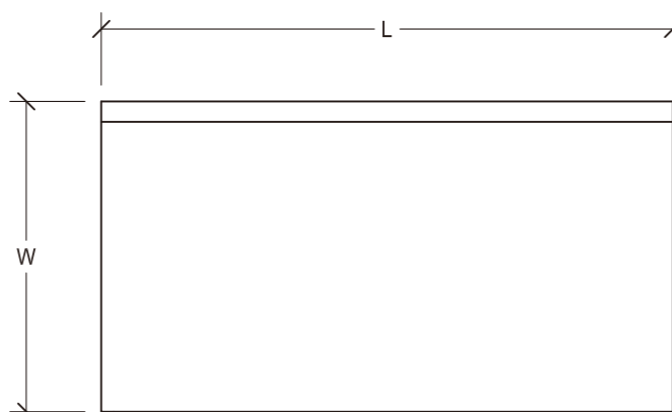

PLAN

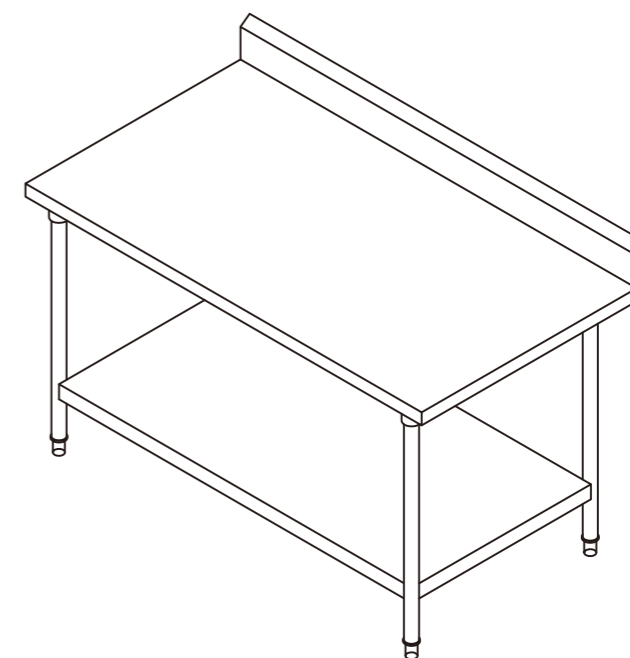

ISOMETRIC VIEW

No:	Item No(款号):	Qty(数量):	No:	Item No(款号):	Qty(数量):

Remark(备注):



SPOT WELDED A THREADED SHAFT TO THE UNDERSIDE OF WORK TOP / SHELF. THEN USE UNITS TO FIX WITH THE REINFORCEMENT / BRACKETS

技术说明:				SKU:			
1.所有产品边缘不能有毛刺, 覆膜面不能刮花;				名称:	建德C40+潜水俱乐部厨房		
2.公差要求标准: 符合GB/T G3280-2015不锈钢冷轧钢板和钢带标准中PT.A的公称宽度要求;				材料:			
3.所有标注尺寸为外尺寸;				编制:		日期:	
4.未注膜面方向朝外。				审核:		日期:	
A						视角:	☉
版本		批准	日期			版本:	A

STAINLESS STEEL SHOP DRAWING (CUSTOM)

不锈钢件生产要求图

Product Description (产品说明):	Cocktail Station W/Sink
	鸡尾酒台连星盆
Model Type (模具型号):	TCOC-S N08

No:	Parts(零部件):	Material Specification(用料标准):
✓ 01	COUNTER TOP 柜台面	16GA. THK. SUS 304 S/S
✓ 02	LEG 支腿	∅38mm 16 GA. THK. SUS 304 S/S TUBE
✓ 03	ADJUSTABLE FOOT INSERT 可调节嵌入式底脚	LUI CHUEN KEE (CHN)
✓ 04	REINFORCEMENT 加固件	16 GA. THK. SUS 304 S/S
✓ 05	SINK BOWL 洗碗槽	16 GA. THK. SUS 304 S/S
06	SINK WASTE 废料槽	
✓ 07	S.S. CROSS RAIL 横梁	∅32mm 16 GA. THK. SUS 304 S/S TUBE
08	WALL MOUNTED BRACKET 壁装托架	16 GA. THK. SUS 304 S/S
09	UNDER SHELF 底架	18 GA. THK. SUS 304 S/S
✓ 10	MIXING FAUCET 混合龙头	
11	OVER SHELF 顶架	18 GA. THK. SUS 304 S/S
12	OUTER DOOR PANEL 外板	20 GA. THK. SUS 304 S/S
13	INNER DOOR PANEL 内板	22 GA. THK. SUS 304 S/S
✓ 14	CABINET BODY 柜身	20 GA. THK. SUS 304 S/S
15	CORNER BUMPER 拐角防护套	COLSON (CHN)
16	SWIVEL CASTOR 旋转角轮	GLOBE (CHN)
17	SOUND DEADEN MATERIAL 隔音材料	3mm THICKNESS
18	WALL FLASHING 防水面	20 GA. THK. SUS 304 S/S
19	CONDENSING UNIT 制冷机组	DANFOSS (CHN)
✓ 20	NOZZLE 排气口	∅25mm SUS 304 S/S TUBE

No:	Item No(款号):	Qty(数量):	No:	Item No(款号):	Qty(数量):

Remark(备注):



M5 SPOT WELDED A THREADED SHAFT TO THE UNDERSIDE OF WORK TOP / SHELF. THEN USE UNITS TO FIX WITH THE REINFORCEMENT / BRACKETS

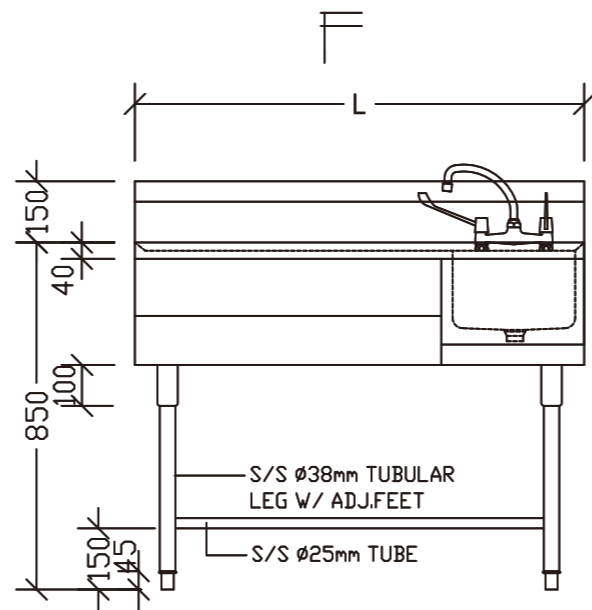

ELEVATION

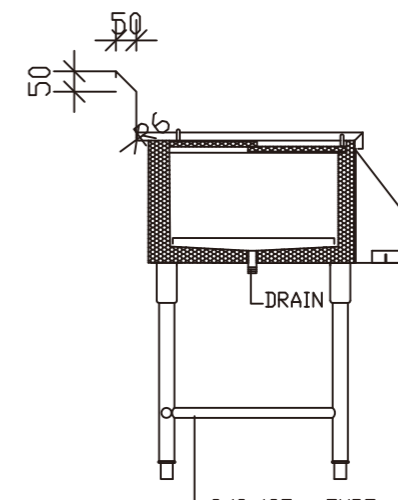

SECTION

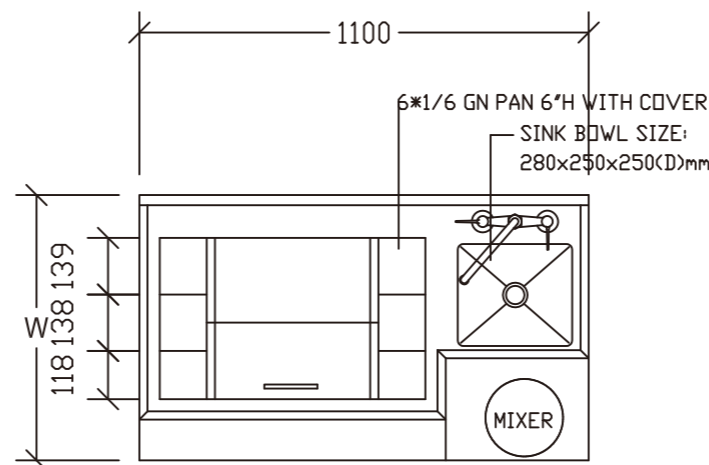

PLAN

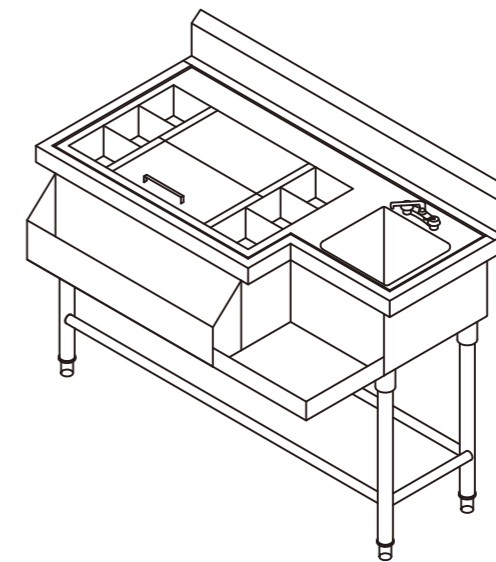

ISOMETRIC VIEW

技术说明:				SKU:			
1.所有产品边缘不能有毛刺, 覆膜面不能刮花;				名称:	建德C40+潜水俱乐部厨房		
2.公差要求标准: 符合GB/T G3280-2015不锈钢冷轧钢板和钢带标准中PT.A的公称宽度要求;				材料:			
3.所有标注尺寸为外尺寸;				编制:		日期:	
4.未注膜面方向朝外。				审核:		日期:	
A						视角:	
版本		批准	日期			版本:	A

STAINLESS STEEL SHOP DRAWING (CUSTOM)

不锈钢件生产要求图

Product Description (产品说明):	Work Cabinet
	工作掩门柜
Model Type (模具型号):	CBH N09

No:	Parts(零部件):	Material Specification(用料标准):
✓ 01	COUNTER TOP 柜台面	16GA. THK. SUS 304 S/S
02	LEG 支腿	Ø38mm 16 GA. THK. SUS 304 S/S TUBE
✓ 03	ADJUSTABLE FOOT INSERT 可调节嵌入式底脚	LUI CHUEN KEE (CHN)
✓ 04	REINFORCEMENT 加固件	16 GA. THK. SUS 304 S/S
05	SINK BOWL 洗碗槽	16 GA. THK. SUS 304 S/S
06	SINK WASTE 废料槽	
07	S.S. CROSS RAIL 横梁	Ø32mm 16 GA. THK. SUS 304 S/S TUBE
08	WALL MOUNTED BRACKET 壁装托架	16 GA. THK. SUS 304 S/S
✓ 09	UNDER SHELF 底架	18 GA. THK. SUS 304 S/S
10	MIXING FAUCET 混合龙头	
11	OVER SHELF 顶架	18 GA. THK. SUS 304 S/S
✓ 12	OUTER DOOR PANEL 外板	20 GA. THK. SUS 304 S/S
✓ 13	INNER DOOR PANEL 内板	22 GA. THK. SUS 304 S/S
✓ 14	CABINET BODY 柜身	20 GA. THK. SUS 304 S/S
15	CORNER BUMPER 拐角防护套	COLSON (CHN)
16	SWIVEL CASTOR 旋转角轮	GLOBE (CHN)
17	SOUND DEADEN MATERIAL 隔音材料	3mm THICKNESS
18	WALL FLASHING 防水面	20 GA. THK. SUS 304 S/S
19	CONDENSING UNIT 制冷机组	DANFOSS (CHN)
20	NOZZLE 排气口	Ø25mm SUS 304 S/S TUBE

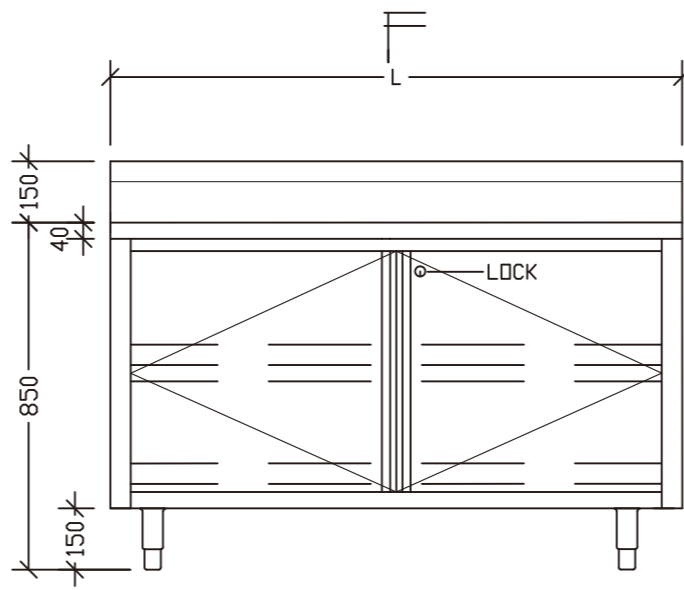

ELEVATION

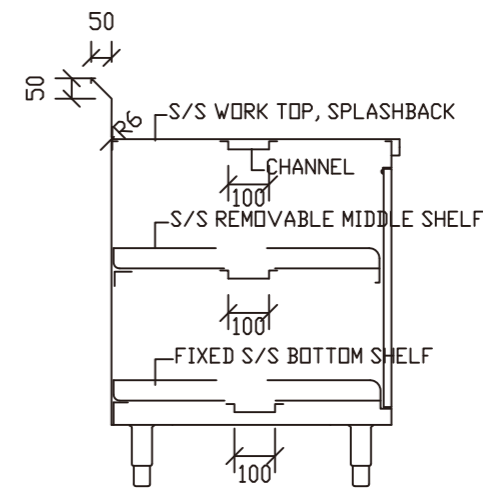

SECTION

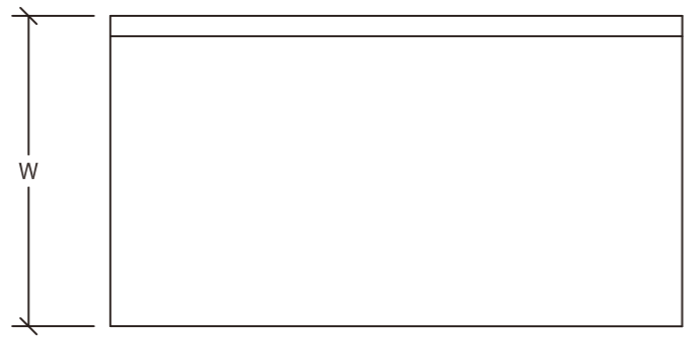

PLAN

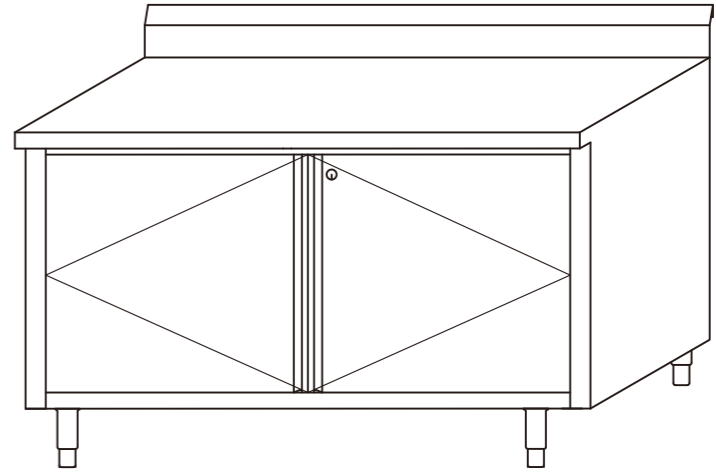

ISOMETRIC VIEW

No:	Item No(款号):	Qty(数量):	No:	Item No(款号):	Qty(数量):

Remark(备注):



SPOT WELDED A THREADED SHAFT TO THE UNDERSIDE OF WORK TOP / SHELF. THEN USE UNITS TO FIX WITH THE REINFORCEMENT / BRACKETS

技术说明:				SKU:			
1.所有产品边缘不能有毛刺, 覆膜面不能刮花;				名称:	建德C40+潜水俱乐部厨房		
2.公差要求标准: 符合GB/T G3280-2015不锈钢冷轧钢板和钢带标准中PT.A的公称宽度要求;				材料:			
3.所有标注尺寸为外尺寸;				编制:		日期:	
4.未注膜面方向朝外。				审核:		日期:	
A						视角:	☉
版本			批准	日期		版本:	A

STAINLESS STEEL SHOP DRAWING (CUSTOM)

不锈钢件生产要求图

Product Description (产品说明):	Hand Wash Sink
	挂墙洗手星盆
Model Type (模具型号):	SHSC1-W P01

No:	Parts(零部件):	Material Specfication(用料标准):
✓ 01	COUNTER TOP 柜台面	16GA. THK. SUS 304 S/S
02	LEG 支腿	∅38mm 16 GA. THK. SUS 304 S/S TUBE
03	ADJUSTABLE FOOT INSERT 可调节嵌入式底脚	LUI CHUEN KEE (CHN)
✓ 04	REINFORCEMENT 加固件	16 GA. THK. SUS 304 S/S
✓ 05	SINK BOWL 洗碗槽	16 GA. THK. SUS 304 S/S
06	SINK WASTE 废料槽	
07	S.S. CROSS RAIL 横梁	∅32mm 16 GA. THK. SUS 304 S/S TUBE
✓ 08	WALL MOUNTED BRACKET 壁装托架	16 GA. THK. SUS 304 S/S
09	UNDER SHELF 底架	18 GA. THK. SUS 304 S/S
✓ 10	MIXING FAUCET 混合龙头	
11	OVER SHELF 顶架	18 GA. THK. SUS 304 S/S
12	OUTER DOOR PANEL 外板	20 GA. THK. SUS 304 S/S
13	INNER DOOR PANEL 内板	22 GA. THK. SUS 304 S/S
14	CABINET BODY 柜身	20 GA. THK. SUS 304 S/S
15	CORNER BUMPER 拐角防护套	COLSON (CHN)
16	SWIVEL CASTOR 旋转角轮	GLOBE (CHN)
17	SOUND DEADEN MATERIAL 隔音材料	3mm THICKNESS
18	WALL FLASHING 防水面	20 GA. THK. SUS 304 S/S
19	CONDENSING UNIT 制冷机组	DANFOSS (CHN)
20	NOZZLE 排气口	∅25mm SUS 304 S/S TUBE

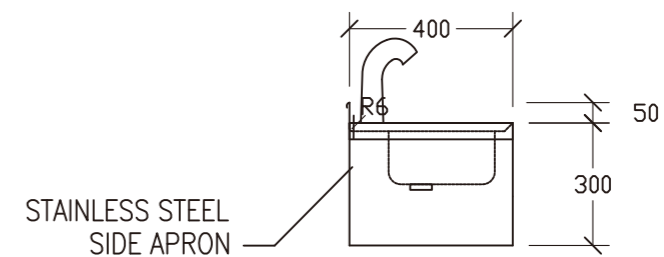
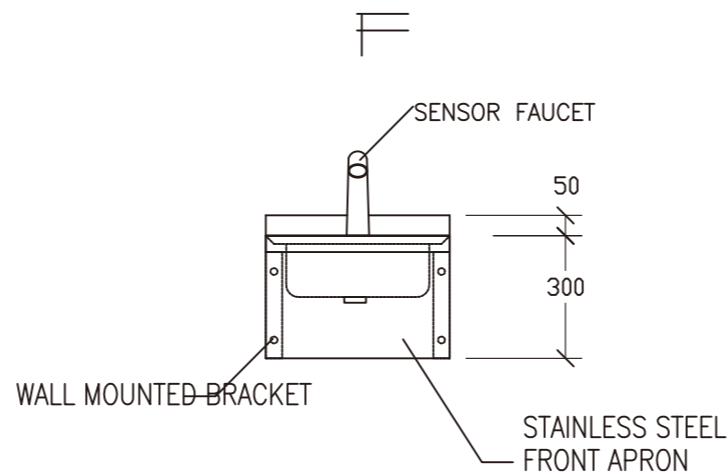

ELEVATION

SECTION

No:	Item No(款号):	Qty(数量):	No:	Item No(款号):	Qty(数量):

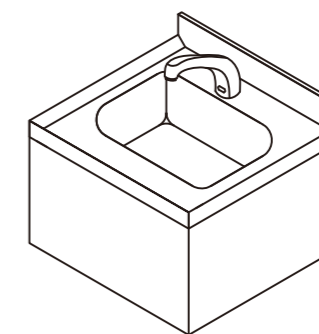
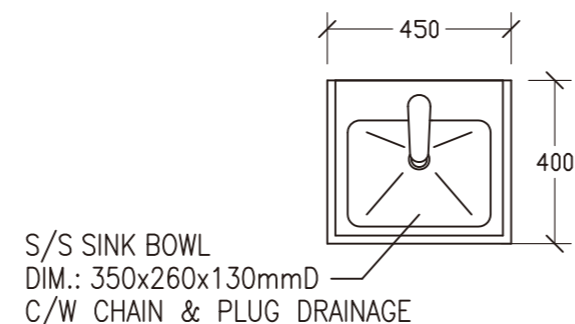

Remark(备注):



SPOT WELDED A THREADED SHAFT TO THE UNDERSIDE OF WORK TOP / SHELF. THEN USE UNITS TO FIX WITH THE REINFORCEMENT / BRACKETS

技术说明:				SKU:			
1.所有产品边缘不能有毛刺, 覆膜面不能刮花;				名称:	建德C40+潜水俱乐部厨房		
2.公差要求标准: 符合GB/T G3280-2015不锈钢冷轧钢板和钢带标准中PT.A的公称宽度要求;				材料:			
3.所有标注尺寸为外尺寸;				编制:		日期:	
4.未注膜面方向朝外。				审核:		日期:	
A						视角:	☉
版本		批准	日期			版本:	A

STAINLESS STEEL SHOP DRAWING (CUSTOM)

不锈钢件生产要求图

Product Description (产品说明):	Work Table
	单层工作台
Model Type (模具型号):	TB P03

No:	Parts(零部件):	Material Specfication(用料标准):
✓ 01	COUNTER TOP 柜台面	16GA. THK. SUS 304 S/S
✓ 02	LEG 支腿	∅38mm 16 GA. THK. SUS 304 S/S TUBE
✓ 03	ADJUSTABLE FOOT INSERT 可调节嵌入式底脚	LUI CHUEN KEE (CHN)
✓ 04	REINFORCEMENT 加固件	16 GA. THK. SUS 304 S/S
05	SINK BOWL 洗碗槽	16 GA. THK. SUS 304 S/S
06	SINK WASTE 废料槽	
✓ 07	S.S. CROSS RAIL 横梁	∅32mm 16 GA. THK. SUS 304 S/S TUBE
08	WALL MOUNTED BRACKET 壁装托架	16 GA. THK. SUS 304 S/S
09	UNDER SHELF 底架	18 GA. THK. SUS 304 S/S
10	MIXING FAUCET 混合龙头	
11	OVER SHELF 顶架	18 GA. THK. SUS 304 S/S
12	OUTER DOOR PANEL 外板	20 GA. THK. SUS 304 S/S
13	INNER DOOR PANEL 内板	22 GA. THK. SUS 304 S/S
14	CABINET BODY 柜身	20 GA. THK. SUS 304 S/S
15	CORNER BUMPER 拐角防护套	COLSON (CHN)
16	SWIVEL CASTOR 旋转角轮	GLOBE (CHN)
17	SOUND DEADEN MATERIAL 隔音材料	3mm THICKNESS
18	WALL FLASHING 防水面	20 GA. THK. SUS 304 S/S
19	CONDENSING UNIT 制冷机组	DANFOSS (CHN)
20	NOZZLE 排气口	∅25mm SUS 304 S/S TUBE

No:	Item No(款号):	Qty(数量):	No:	Item No(款号):	Qty(数量):

Remark(备注):

 M5

SPOT WELDED A THREADED SHAFT TO THE UNDERSIDE OF WORK TOP / SHELF. THEN USE UNITS TO FIX WITH THE REINFORCEMENT / BRACKETS

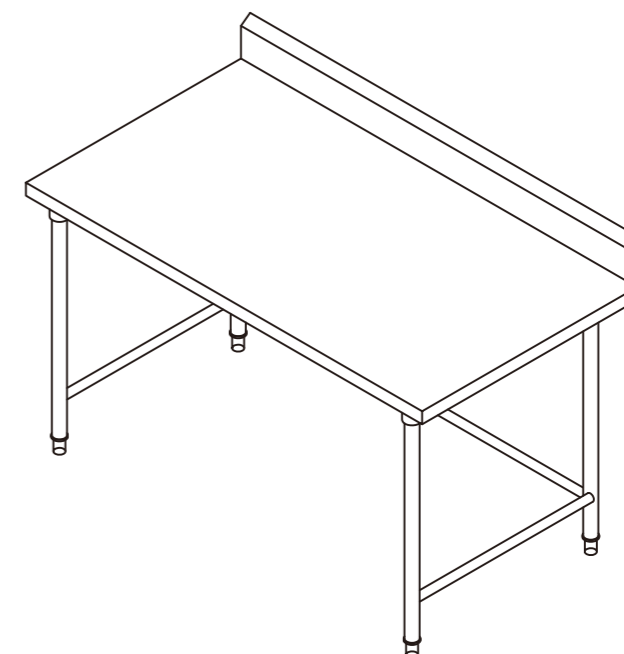
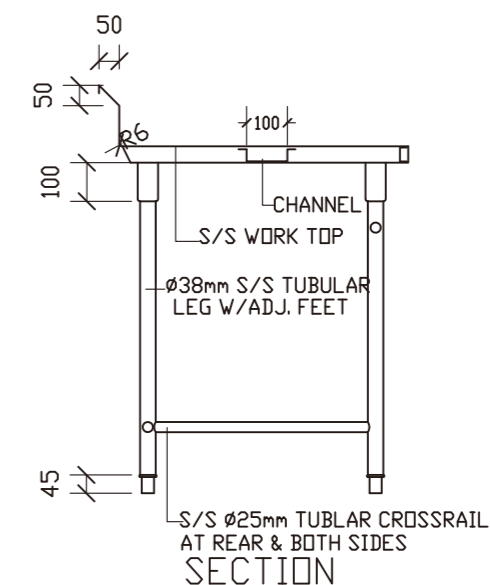
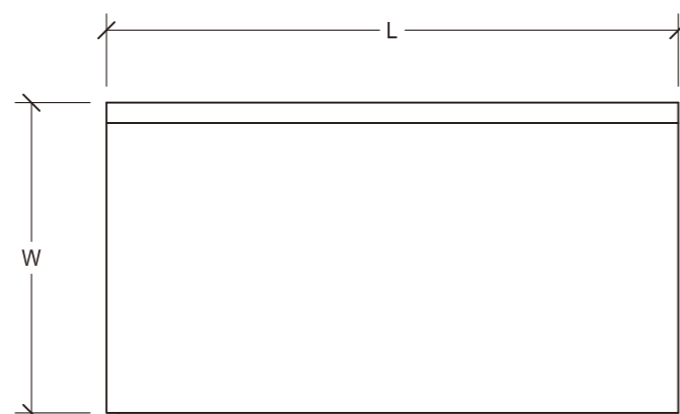
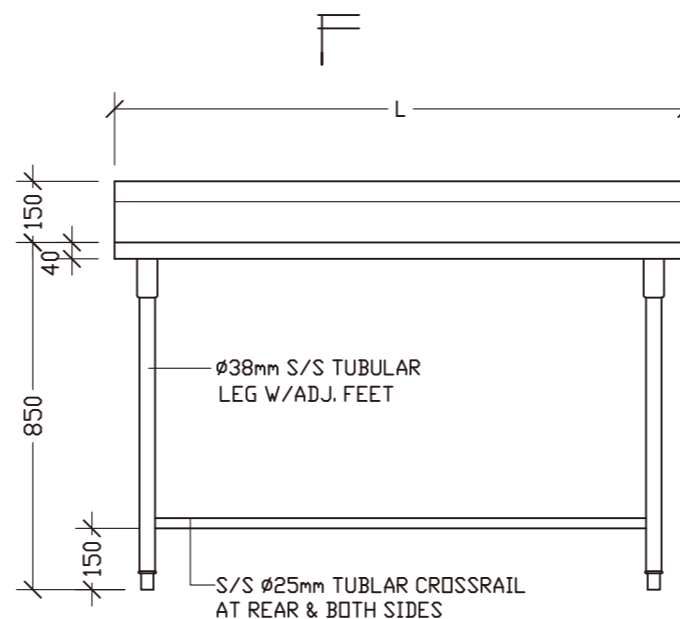

ISOMETRIC VIEW

技术说明:				SKU:			
1.所有产品边缘不能有毛刺, 覆膜面不能刮花;				名称:	建德C40+潜水俱乐部厨房		
2.公差要求标准: 符合GB/T G3280-2015不锈钢冷轧钢板和钢带标准中PT.A的公称宽度要求;				材料:			
3.所有标注尺寸为外尺寸;				编制:		日期:	
4.未注膜面方向朝外。				审核:		日期:	
A						视角:	
版本		批准	日期			版本:	A

STAINLESS STEEL SHOP DRAWING (CUSTOM)

不锈钢件生产要求图

Product Description (产品说明):	Single Wall Mounted Shelving
	单层挂墙层架
Model Type (模具型号):	JBW1 P04

No:	Parts(零部件):	Material Specification(用料标准):
01	COUNTER TOP 柜台面	16GA. THK. SUS 304 S/S
02	LEG 支腿	∅38mm 16 GA. THK. SUS 304 S/S TUBE
03	ADJUSTABLE FOOT INSERT 可调节嵌入式底脚	LUI CHUEN KEE (CHN)
✓ 04	REINFORCEMENT 加固件	16 GA. THK. SUS 304 S/S
05	SINK BOWL 洗碗槽	16 GA. THK. SUS 304 S/S
06	SINK WASTE 废料槽	
07	S.S. CROSS RAIL 横梁	∅32mm 16 GA. THK. SUS 304 S/S TUBE
✓ 08	WALL MOUNTED BRACKET 壁装托架	16 GA. THK. SUS 304 S/S
09	UNDER SHELF 底架	18 GA. THK. SUS 304 S/S
10	MIXING FAUCET 混合龙头	
✓ 11	OVER SHELF 顶架	18 GA. THK. SUS 304 S/S
12	OUTER DOOR PANEL 外板	20 GA. THK. SUS 304 S/S
13	INNER DOOR PANEL 内板	22 GA. THK. SUS 304 S/S
14	CABINET BODY 柜身	20 GA. THK. SUS 304 S/S
15	CORNER BUMPER 拐角防护套	COLSON (CHN)
16	SWIVEL CASTOR 旋转角轮	GLOBE (CHN)
17	SOUND DEADEN MATERIAL 隔音材料	3mm THICKNESS
18	WALL FLASHING 防水面	20 GA. THK. SUS 304 S/S
19	CONDENSING UNIT 制冷机组	DANFOSS (CHN)
20	NOZZLE 排气口	∅25mm SUS 304 S/S TUBE

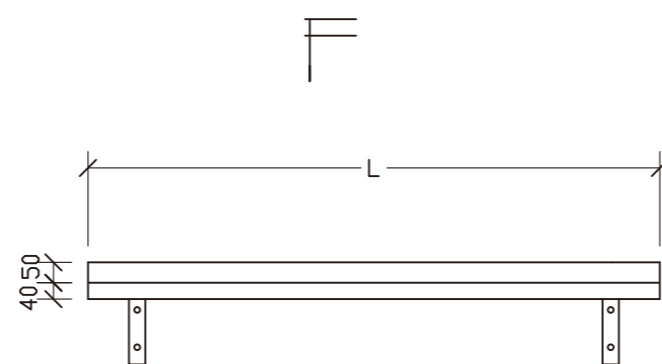

ELEVATION

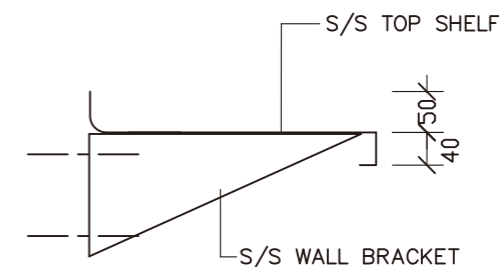

SECTION

No:	Item No(款号):	Qty(数量):	No:	Item No(款号):	Qty(数量):

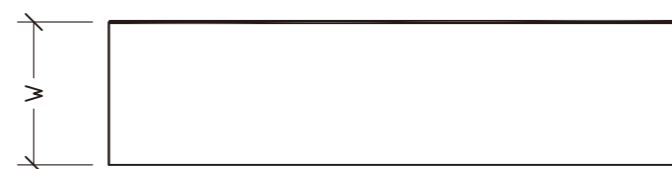

PLAN

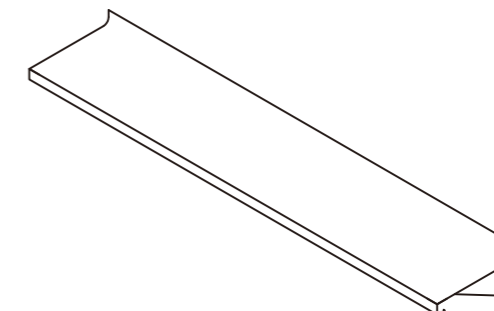

ISOMETRIC VIEW

Remark(备注):



SPOT WELDED A THREADED SHAFT TO THE UNDERSIDE OF WORK TOP / SHELF. THEN USE UNITS TO FIX WITH THE REINFORCEMENT / BRACKETS

技术说明:				SKU:			
1.所有产品边缘不能有毛刺, 覆膜面不能刮花;				名称:	建德C40+潜水俱乐部厨房		
2.公差要求标准: 符合GB/T G3280-2015不锈钢冷轧钢板和钢带标准中PT.A的公称宽度要求;				材料:			
3.所有标注尺寸为外尺寸;				编制:		日期:	
4.未注膜面方向朝外。				审核:		日期:	
A						视角:	☉
版本		批准	日期			版本:	A

STAINLESS STEEL SHOP DRAWING (CUSTOM)

不锈钢件生产要求图

Product Description (产品说明):	Wash Sink
	三星
Model Type (模具型号):	SPSC3P P05

No:	Parts(零部件):	Material Specfication(用料标准):
✓ 01	COUNTER TOP 柜台面	16GA. THK. SUS 304 S/S
✓ 02	LEG 支腿	∅38mm 16 GA. THK. SUS 304 S/S TUBE
✓ 03	ADJUSTABLE FOOT INSERT 可调节嵌入式底脚	LUI CHUEN KEE (CHN)
✓ 04	REINFORCEMENT 加固件	16 GA. THK. SUS 304 S/S
✓ 05	SINK BOWL 洗碗槽	16 GA. THK. SUS 304 S/S
06	SINK WASTE 废料槽	
✓ 07	S.S. CROSS RAIL 横梁	∅32mm 16 GA. THK. SUS 304 S/S TUBE
08	WALL MOUNTED BRACKET 壁装托架	16 GA. THK. SUS 304 S/S
09	UNDER SHELF 底架	18 GA. THK. SUS 304 S/S
✓ 10	MIXING FAUCET 混合龙头	
✓ 11	OVER SHELF 顶架	18 GA. THK. SUS 304 S/S
12	OUTER DOOR PANEL 外板	20 GA. THK. SUS 304 S/S
13	INNER DOOR PANEL 内板	22 GA. THK. SUS 304 S/S
14	CABINET BODY 柜身	20 GA. THK. SUS 304 S/S
15	CORNER BUMPER 拐角防护套	COLSON (CHN)
16	SWIVEL CASTOR 旋转角轮	GLOBE (CHN)
17	SOUND DEADEN MATERIAL 隔音材料	3mm THICKNESS
18	WALL FLASHING 防水面	20 GA. THK. SUS 304 S/S
19	CONDENSING UNIT 制冷机组	DANFOSS (CHN)
20	NOZZLE 排气口	∅25mm SUS 304 S/S TUBE

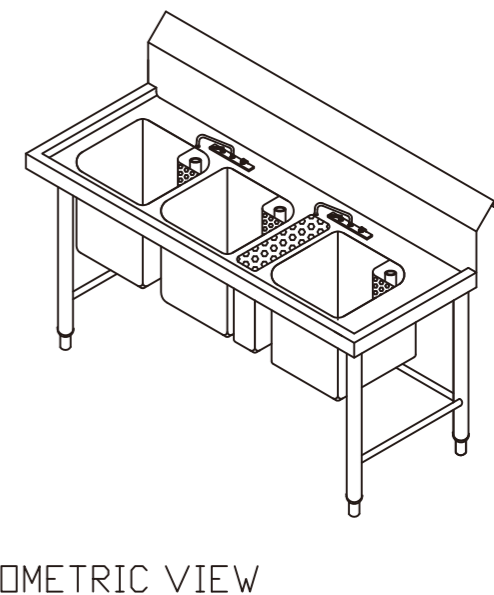
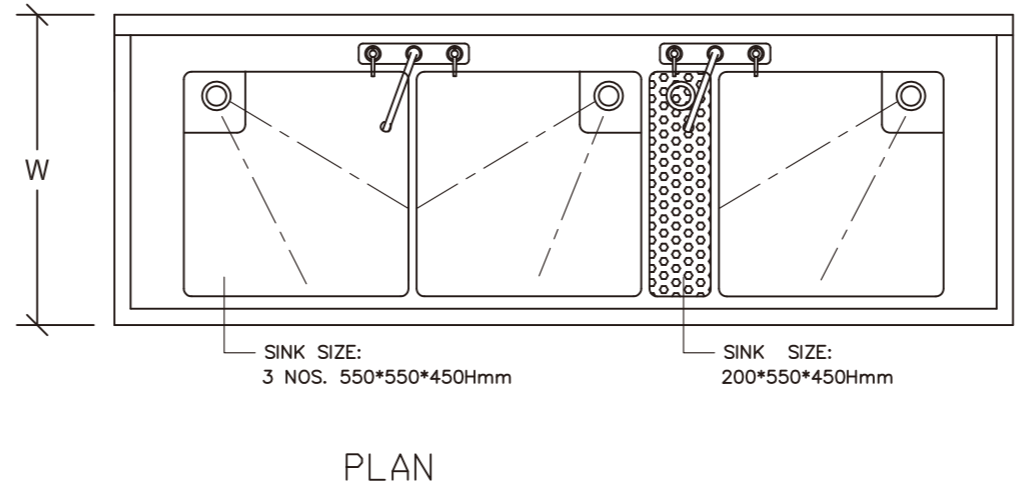
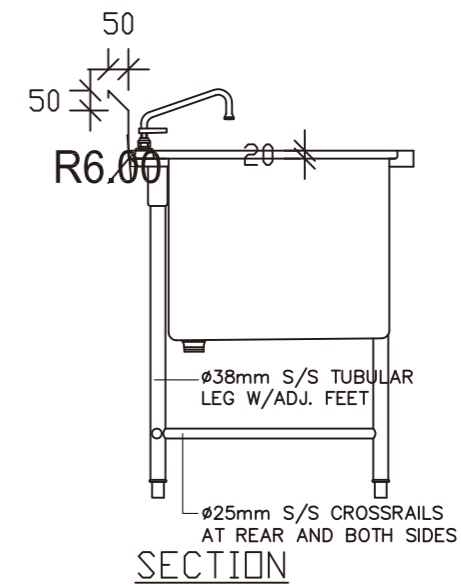
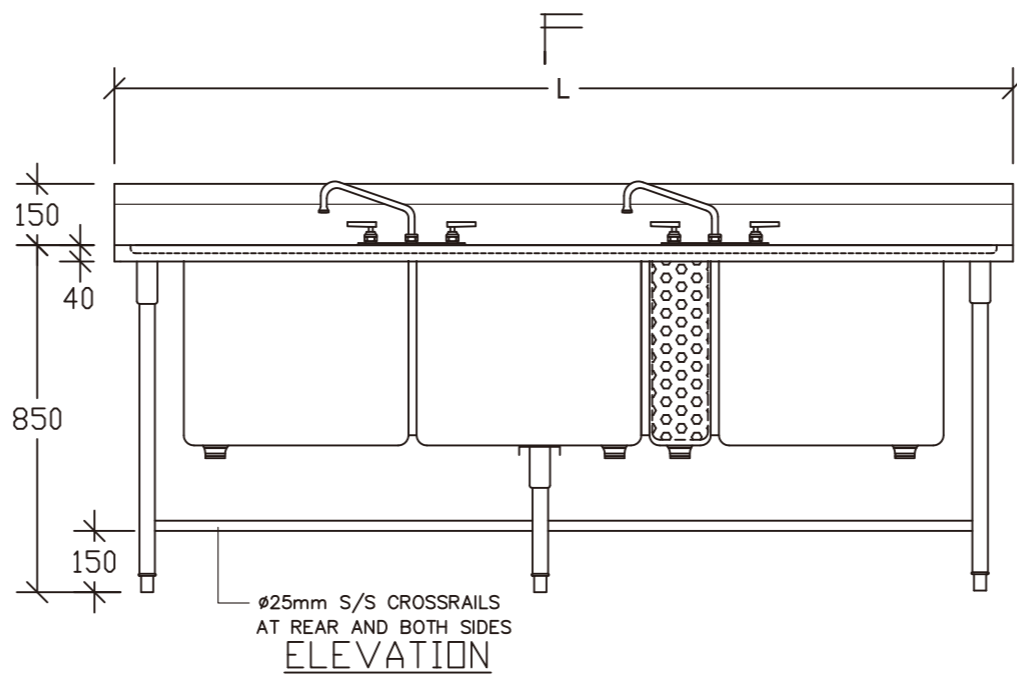

No:	Item No(款号):	Qty(数量):	No:	Item No(款号):	Qty(数量):

Remark(备注):

M5

SPOT WELDED A THREADED SHAFT TO THE UNDERSIDE OF WORK TOP / SHELF. THEN USE UNITS TO FIX WITH THE REINFORCEMENT / BRACKETS

技术说明:				SKU:			
1.所有产品边缘不能有毛刺, 覆膜面不能刮花;				名称:	建德C40+潜水俱乐部厨房		
2.公差要求标准: 符合GB/T G3280-2015不锈钢冷轧钢板和钢带标准中PT.A的公称宽度要求;				材料:			
3.所有标注尺寸为外尺寸;				编制:		日期:	
4.未注膜面方向朝外。				审核:		日期:	
A						视角:	☉
版本		批准	日期			版本:	A

STAINLESS STEEL SHOP DRAWING (CUSTOM)

不锈钢件生产要求图

Product Description (产品说明):	Work Table
	工作台
Model Type (模具型号):	TB P09

No:	Parts(零部件):	Material Specification(用料标准):
✓ 01	COUNTER TOP 柜台面	16GA. THK. SUS 304 S/S
✓ 02	LEG 支腿	∅38mm 16 GA. THK. SUS 304 S/S TUBE
✓ 03	ADJUSTABLE FOOT INSERT 可调节嵌入式底脚	LUI CHUEN KEE (CHN)
✓ 04	REINFORCEMENT 加固件	16 GA. THK. SUS 304 S/S
05	SINK BOWL 洗碗槽	16 GA. THK. SUS 304 S/S
06	SINK WASTE 废料槽	
✓ 07	S.S. CROSS RAIL 横梁	∅32mm 16 GA. THK. SUS 304 S/S TUBE
08	WALL MOUNTED BRACKET 壁装托架	16 GA. THK. SUS 304 S/S
09	UNDER SHELF 底架	18 GA. THK. SUS 304 S/S
10	MIXING FAUCET 混合龙头	
11	OVER SHELF 顶架	18 GA. THK. SUS 304 S/S
12	OUTER DOOR PANEL 外板	20 GA. THK. SUS 304 S/S
13	INNER DOOR PANEL 内板	22 GA. THK. SUS 304 S/S
14	CABINET BODY 柜身	20 GA. THK. SUS 304 S/S
15	CORNER BUMPER 拐角防护套	COLSON (CHN)
16	SWIVEL CASTOR 旋转角轮	GLOBE (CHN)
17	SOUND DEADEN MATERIAL 隔音材料	3mm THICKNESS
18	WALL FLASHING 防水面	20 GA. THK. SUS 304 S/S
19	CONDENSING UNIT 制冷机组	DANFOSS (CHN)
20	NOZZLE 排气口	∅25mm SUS 304 S/S TUBE

No:	Item No(款号):	Qty(数量):	No:	Item No(款号):	Qty(数量):

Remark(备注):



SPOT WELDED A THREADED SHAFT TO THE UNDERSIDE OF WORK TOP / SHELF. THEN USE UNITS TO FIX WITH THE REINFORCEMENT / BRACKETS

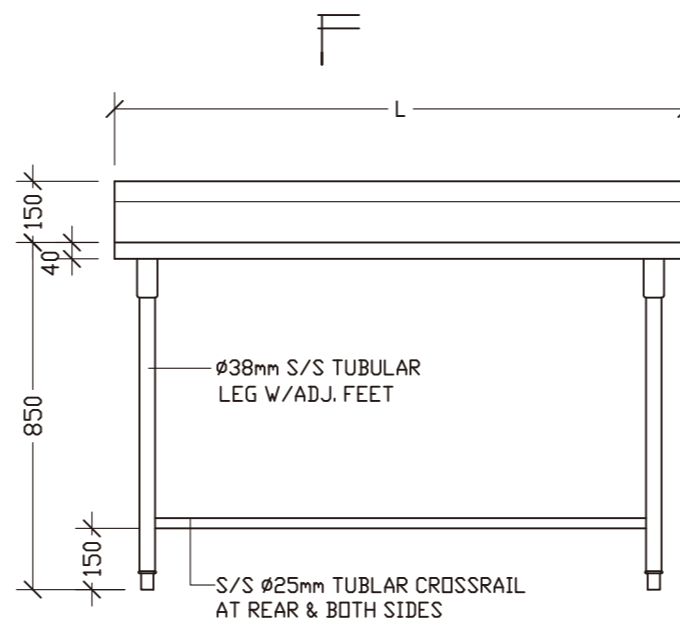

ELEVATION

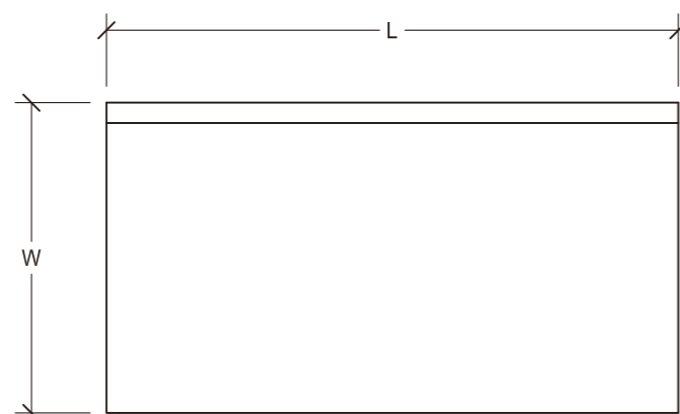

PLAN

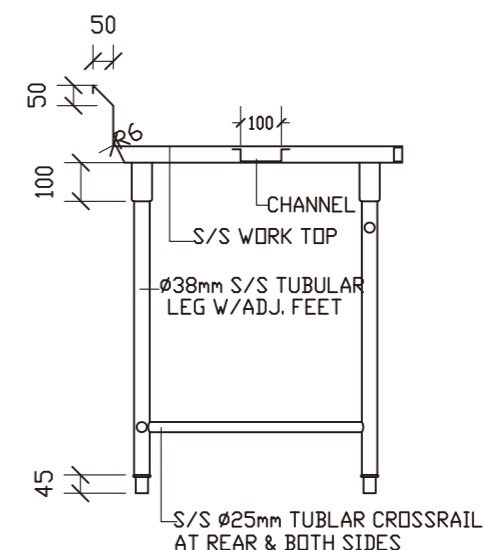

SECTION

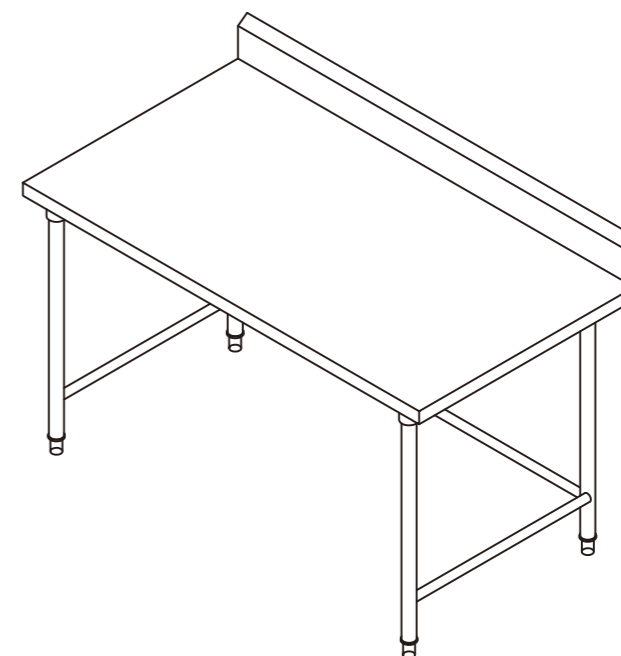

ISOMETRIC VIEW

技术说明:				SKU:			
1.所有产品边缘不能有毛刺, 覆膜面不能刮花;				名称:	建德C40+潜水俱乐部厨房		
2.公差要求标准: 符合GB/T G3280-2015不锈钢冷轧钢板和钢带标准中PT.A的公称宽度要求;				材料:			
3.所有标注尺寸为外尺寸;				编制:		日期:	
4.未注膜面方向朝外。				审核:		日期:	
A						视角:	☉ ☒
版本		批准	日期			版本:	A

STAINLESS STEEL SHOP DRAWING (CUSTOM)

不锈钢件生产要求图

Product Description (产品说明):	Single Wall Mounted Shelving
	单层挂墙层架
Model Type (模具型号):	JBW1 P10

No:	Parts(零部件):	Material Specification(用料标准):
01	COUNTER TOP 柜台面	16GA. THK. SUS 304 S/S
02	LEG 支腿	∅38mm 16 GA. THK. SUS 304 S/S TUBE
03	ADJUSTABLE FOOT INSERT 可调节嵌入式底脚	LUI CHUEN KEE (CHN)
✓ 04	REINFORCEMENT 加固件	16 GA. THK. SUS 304 S/S
05	SINK BOWL 洗碗槽	16 GA. THK. SUS 304 S/S
06	SINK WASTE 废料槽	
07	S.S. CROSS RAIL 横梁	∅32mm 16 GA. THK. SUS 304 S/S TUBE
✓ 08	WALL MOUNTED BRACKET 壁装托架	16 GA. THK. SUS 304 S/S
09	UNDER SHELF 底架	18 GA. THK. SUS 304 S/S
10	MIXING FAUCET 混合龙头	
✓ 11	OVER SHELF 顶架	18 GA. THK. SUS 304 S/S
12	OUTER DOOR PANEL 外板	20 GA. THK. SUS 304 S/S
13	INNER DOOR PANEL 内板	22 GA. THK. SUS 304 S/S
14	CABINET BODY 柜身	20 GA. THK. SUS 304 S/S
15	CORNER BUMPER 拐角防护套	COLSON (CHN)
16	SWIVEL CASTOR 旋转角轮	GLOBE (CHN)
17	SOUND DEADEN MATERIAL 隔音材料	3mm THICKNESS
18	WALL FLASHING 防水面	20 GA. THK. SUS 304 S/S
19	CONDENSING UNIT 制冷机组	DANFOSS (CHN)
20	NOZZLE 排气口	∅25mm SUS 304 S/S TUBE

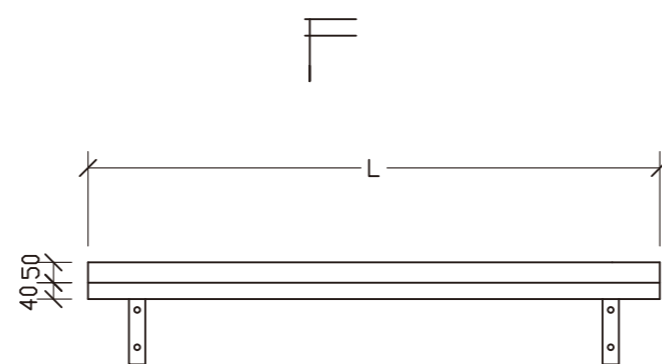

ELEVATION

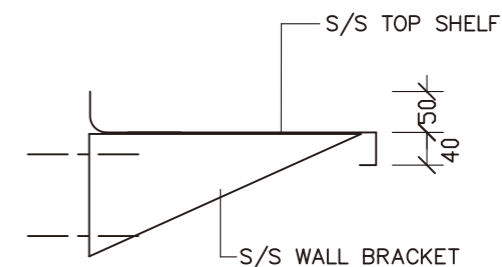

SECTION

No:	Item No(款号):	Qty(数量):	No:	Item No(款号):	Qty(数量):

Remark(备注):



SPOT WELDED A THREADED SHAFT TO THE UNDERSIDE OF WORK TOP / SHELF. THEN USE UNITS TO FIX WITH THE REINFORCEMENT / BRACKETS

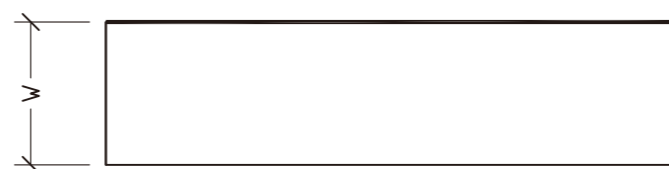

PLAN

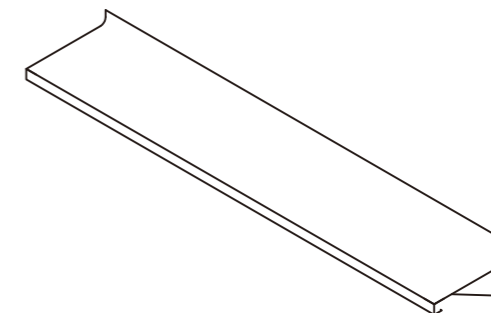

ISOMETRIC VIEW

技术说明:				SKU:			
1.所有产品边缘不能有毛刺, 覆膜面不能刮花;				名称:	建德C40+潜水俱乐部厨房		
2.公差要求标准: 符合GB/T G3280-2015不锈钢冷轧钢板和钢带标准中PT.A的公称宽度要求;				材料:			
3.所有标注尺寸为外尺寸;				编制:		日期:	
4.未注膜面方向朝外。				审核:		日期:	
A						视角:	☉
版本		批准	日期			版本:	A

STAINLESS STEEL SHOP DRAWING (CUSTOM)

不锈钢件生产要求图

Product Description (产品说明):	Work Table W/Under Shelf
	调料平台
Model Type (模具型号):	TBS1 Q09

No:	Parts(零部件):	Material Specification(用料标准):
✓ 01	COUNTER TOP 柜台面	16GA. THK. SUS 304 S/S
✓ 02	LEG 支腿	Ø38mm 16 GA. THK. SUS 304 S/S TUBE
✓ 03	ADJUSTABLE FOOT INSERT 可调节嵌入式底脚	LUI CHUEN KEE (CHN)
✓ 04	REINFORCEMENT 加固件	16 GA. THK. SUS 304 S/S
05	SINK BOWL 洗碗槽	16 GA. THK. SUS 304 S/S
06	SINK WASTE 废料槽	
✓ 07	S.S. CROSS RAIL 横梁	Ø32mm 16 GA. THK. SUS 304 S/S TUBE
08	WALL MOUNTED BRACKET 壁挂托架	16 GA. THK. SUS 304 S/S
09	UNDER SHELF 底架	18 GA. THK. SUS 304 S/S
10	MIXING FAUCET 混合龙头	
11	OVER SHELF 顶架	18 GA. THK. SUS 304 S/S
12	OUTER DOOR PANEL 外板	20 GA. THK. SUS 304 S/S
13	INNER DOOR PANEL 内板	22 GA. THK. SUS 304 S/S
14	CABINET BODY 柜身	20 GA. THK. SUS 304 S/S
15	CORNER BUMPER 拐角防护套	COLSON (CHN)
16	SWIVEL CASTOR 旋转角轮	GLOBE (CHN)
17	SOUND DEADEN MATERIAL 隔音材料	3mm THICKNESS
18	WALL FLASHING 防水面	20 GA. THK. SUS 304 S/S
19	CONDENSING UNIT 制冷机组	DANFOSS (CHN)
20	NOZZLE 排气口	Ø25mm SUS 304 S/S TUBE

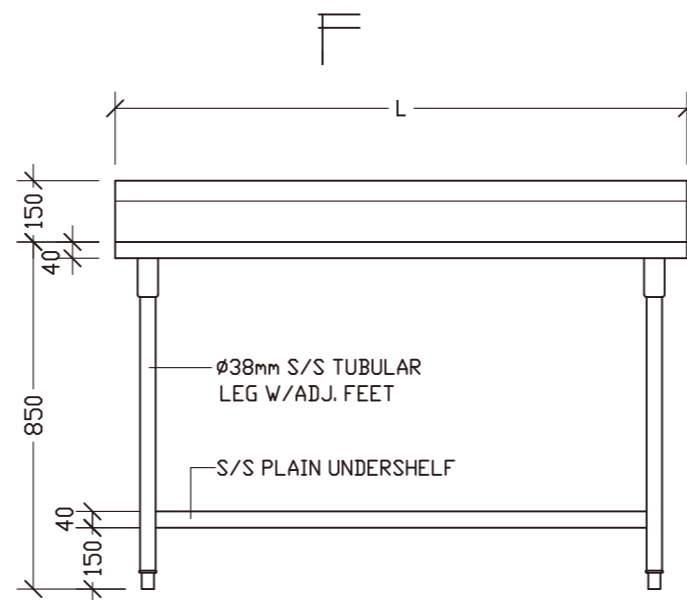

ELEVATION

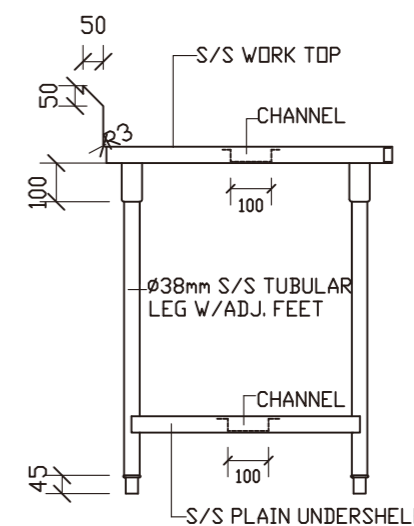

SECTION

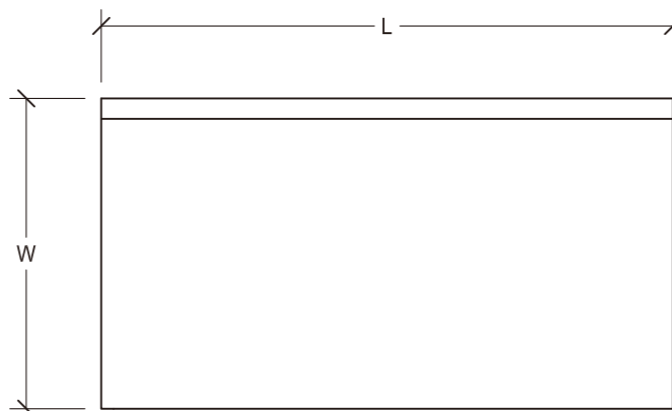

PLAN

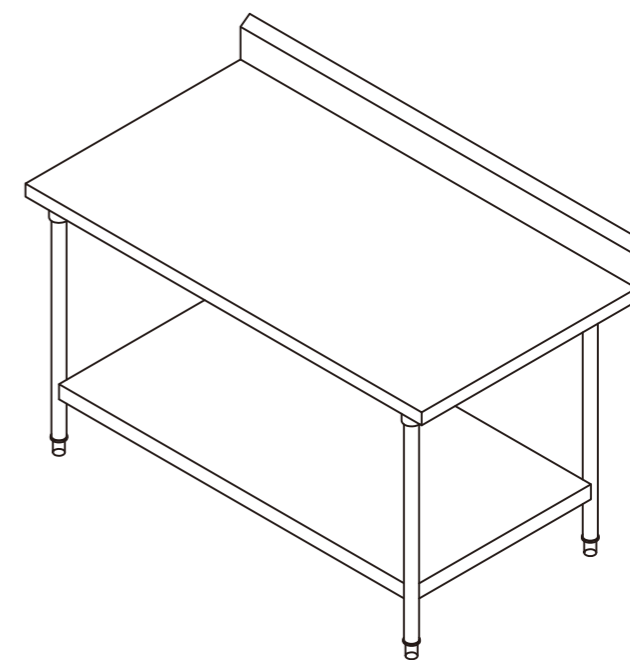

ISOMETRIC VIEW

No:	Item No(款号):	Qty(数量):	No:	Item No(款号):	Qty(数量):

Remark(备注):



SPOT WELDED A THREADED SHAFT TO THE UNDERSIDE OF WORK TOP / SHELF. THEN USE UNITS TO FIX WITH THE REINFORCEMENT / BRACKETS

技术说明:
 1.所有产品边缘不能有毛刺, 覆膜面不能刮花;
 2.公差要求标准: 符合GB/T G3280-2015不锈钢冷轧钢板和钢带标准中PT.A的公称宽度要求;
 3.所有标注尺寸为外尺寸;
 4.未注膜面方向朝外。

SKU:		日期:		视角:	☉ ☒
名称:	建德C40+潜水俱乐部厨房	日期:		版本:	A
材料:					
编制:					
审核:					

STAINLESS STEEL SHOP DRAWING (CUSTOM)

不锈钢件生产要求图

Product Description (产品说明):	4-Tier Square Tube Storage Shelving
	四层通架
Model Type (模具型号):	JFG4 Q11

No:	Parts(零部件):	Material Specification(用料标准):
01	COUNTER TOP 柜台面	16GA. THK. SUS 304 S/S
✓ 02	LEG 支腿	∅38mm 16 GA. THK. SUS 304 S/S TUBE
✓ 03	ADJUSTABLE FOOT INSERT 可调节嵌入式底脚	LUI CHUEN KEE (CHN)
04	REINFORCEMENT 加固件	16 GA. THK. SUS 304 S/S
05	SINK BOWL 洗碗槽	16 GA. THK. SUS 304 S/S
06	SINK WASTE 废料槽	
✓ 07	S.S. CROSS RAIL 横梁	∅32mm 16 GA. THK. SUS 304 S/S TUBE
08	WALL MOUNTED BRACKET 壁装托架	16 GA. THK. SUS 304 S/S
09	UNDER SHELF 底架	18 GA. THK. SUS 304 S/S
10	MIXING FAUCET 混合龙头	
11	OVER SHELF 顶架	18 GA. THK. SUS 304 S/S
12	OUTER DOOR PANEL 外板	20 GA. THK. SUS 304 S/S
13	INNER DOOR PANEL 内板	22 GA. THK. SUS 304 S/S
14	CABINET BODY 柜身	20 GA. THK. SUS 304 S/S
15	CORNER BUMPER 拐角防护套	COLSON (CHN)
16	SWIVEL CASTOR 旋转角轮	GLOBE (CHN)
17	SOUND DEADEN MATERIAL 隔音材料	3mm THICKNESS
18	WALL FLASHING 防水面	20 GA. THK. SUS 304 S/S
19	CONDENSING UNIT 制冷机组	DANFOSS (CHN)
20	NOZZLE 排气口	∅25mm SUS 304 S/S TUBE

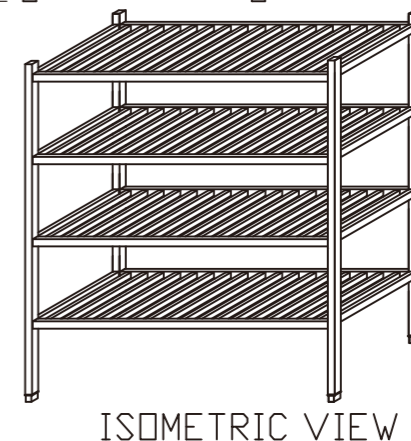
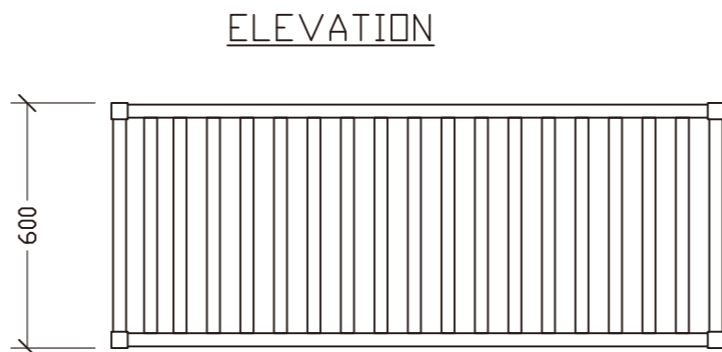
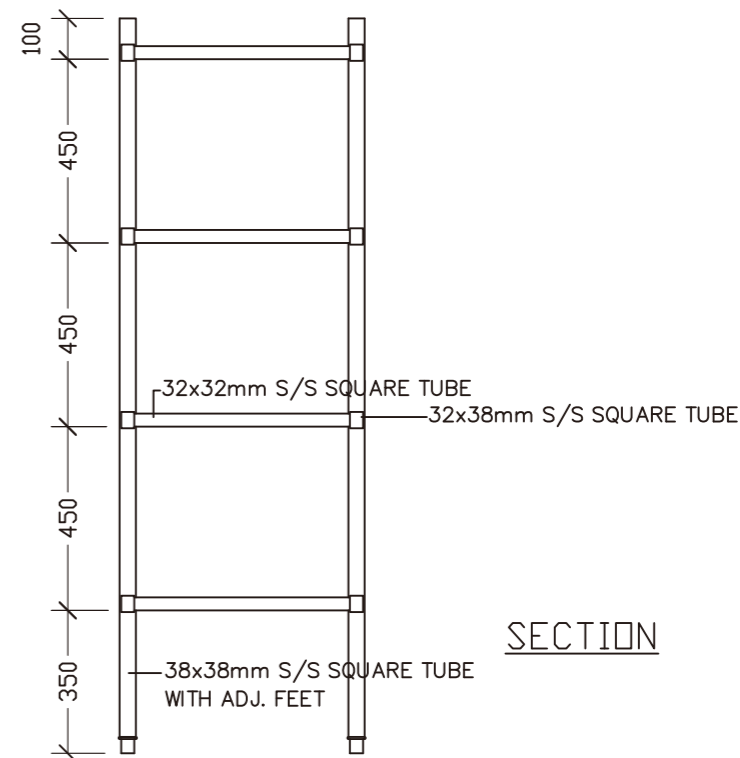
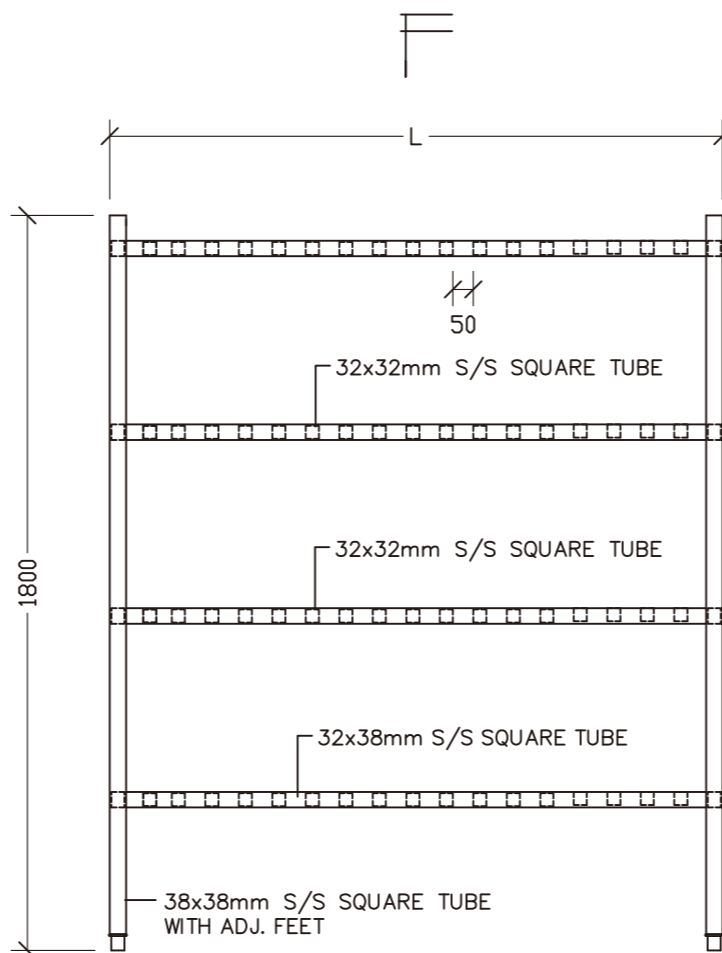

No:	Item No(款号):	Qty(数量):	No:	Item No(款号):	Qty(数量):

Remark(备注):



SPOT WELDED A THREADED SHAFT TO THE UNDERSIDE OF WORK TOP / SHELF. THEN USE UNITS TO FIX WITH THE REINFORCEMENT / BRACKETS

技术说明:
 1.所有产品边缘不能有毛刺, 覆膜面不能刮花;
 2.公差要求标准: 符合GB/T G3280-2015不锈钢冷轧钢板和钢带标准中PT.A的公称宽度要求;
 3.所有标注尺寸为外尺寸;
 4.未注膜面方向朝外。

SKU:
 名称: 建德C40+潜水俱乐部厨房
 材料:
 编制:
 审核:

日期:
 日期:
 视角:
 版本: A

A
 版本
 批准
 日期

STAINLESS STEEL SHOP DRAWING (CUSTOM)

不锈钢件生产要求图

Product Description (产品说明):	Work Counter W/Sink
	工作台连星盆 (中间去水)
Model Type (模具型号):	SBSH1 Q12

No:	Parts(零部件):	Material Specfication(用料标准):
✓ 01	COUNTER TOP 柜台面	16GA. THK. SUS 304 S/S
02	LEG 支腿	Ø38mm 16 GA. THK. SUS 304 S/S TUBE
✓ 03	ADJUSTABLE FOOT INSERT 可调节嵌入式底脚	LUI CHUEN KEE (CHN)
✓ 04	REINFORCEMENT 加固件	16 GA. THK. SUS 304 S/S
✓ 05	SINK BOWL 洗碗槽	16 GA. THK. SUS 304 S/S
06	SINK WASTE 废料槽	
07	S.S. CROSS RAIL 横梁	Ø32mm 16 GA. THK. SUS 304 S/S TUBE
08	WALL MOUNTED BRACKET 壁装托架	16 GA. THK. SUS 304 S/S
09	UNDER SHELF 底架	18 GA. THK. SUS 304 S/S
✓ 10	MIXING FAUCET 混合龙头	
11	OVER SHELF 顶架	18 GA. THK. SUS 304 S/S
✓ 12	OUTER DOOR PANEL 外板	20 GA. THK. SUS 304 S/S
✓ 13	INNER DOOR PANEL 内板	22 GA. THK. SUS 304 S/S
✓ 14	CABINET BODY 柜身	20 GA. THK. SUS 304 S/S
15	CORNER BUMPER 拐角防护套	COLSON (CHN)
16	SWIVEL CASTOR 旋转角轮	GLOBE (CHN)
17	SOUND DEADEN MATERIAL 隔音材料	3mm THICKNESS
18	WALL FLASHING 防水面	20 GA. THK. SUS 304 S/S
19	CONDENSING UNIT 制冷机组	DANFOSS (CHN)
20	NOZZLE 排气口	Ø25mm SUS 304 S/S TUBE

No:	Item No(款号):	Qty(数量):	No:	Item No(款号):	Qty(数量):
	CHO-015	1			

Remark(备注):

 M5

SPOT WELDED A THREADED SHAFT TO THE UNDERSIDE OF WORK TOP / SHELF. THEN USE UNITS TO FIX WITH THE REINFORCEMENT / BRACKETS

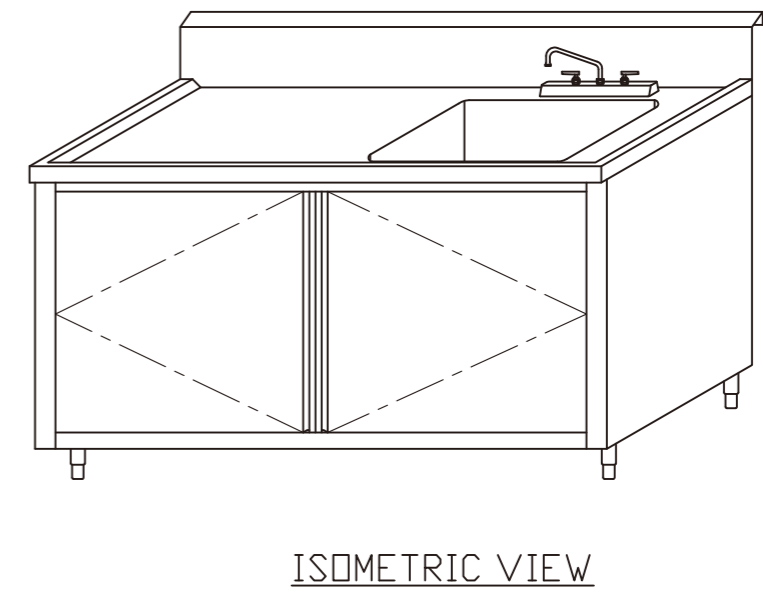
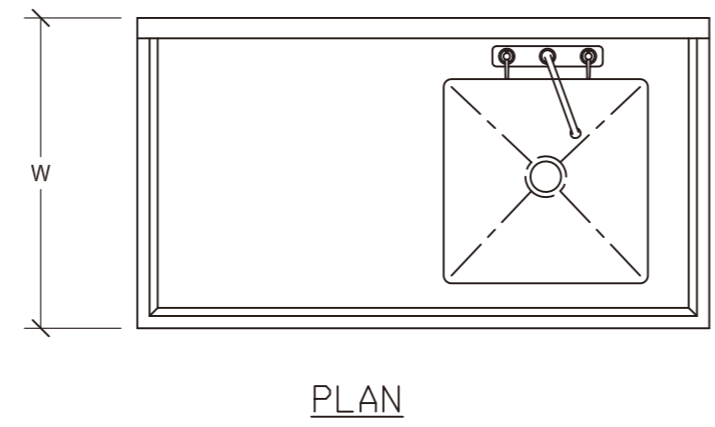
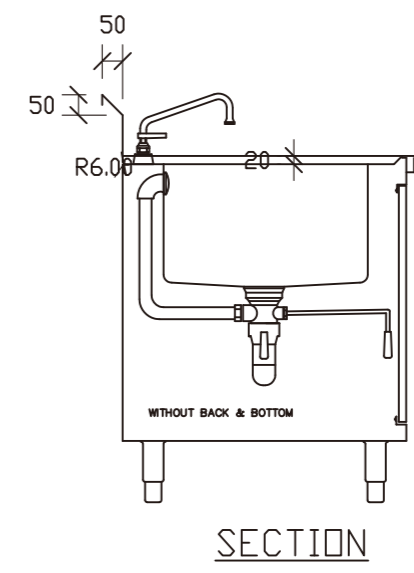
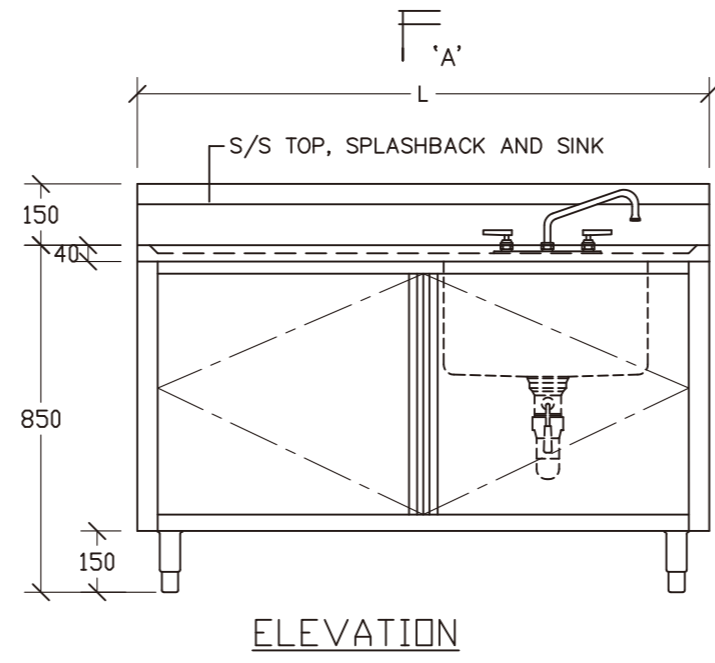

				技术说明:	SKU:				
				1.所有产品边缘不能有毛刺, 覆膜面不能刮花;	名称:	建德C40+潜水俱乐部厨房			
				2.公差要求标准: 符合GB/T G3280-2015不锈钢冷轧钢板和钢带标准中PT.A的公称宽度要求;	材料:				
				3.所有标注尺寸为外尺寸;	编制:				
				4.未注膜面方向朝外。	审核:				
A						日期:		视角:	
版本			批准	日期		日期:		版本:	A

STAINLESS STEEL SHOP DRAWING (CUSTOM)

不锈钢件生产要求图

Product Description (产品说明):	Work Cabinet
	工作掩门柜
Model Type (模具型号):	CBH Q13

No:	Parts(零部件):	Material Specification(用料标准):
✓ 01	COUNTER TOP 柜台面	16GA. THK. SUS 304 S/S
02	LEG 支腿	Ø38mm 16 GA. THK. SUS 304 S/S TUBE
✓ 03	ADJUSTABLE FOOT INSERT 可调节嵌入式底脚	LUI CHUEN KEE (CHN)
✓ 04	REINFORCEMENT 加固件	16 GA. THK. SUS 304 S/S
05	SINK BOWL 洗碗槽	16 GA. THK. SUS 304 S/S
06	SINK WASTE 废料槽	
07	S.S. CROSS RAIL 横梁	Ø32mm 16 GA. THK. SUS 304 S/S TUBE
08	WALL MOUNTED BRACKET 壁装托架	16 GA. THK. SUS 304 S/S
✓ 09	UNDER SHELF 底架	18 GA. THK. SUS 304 S/S
10	MIXING FAUCET 混合龙头	
11	OVER SHELF 顶架	18 GA. THK. SUS 304 S/S
✓ 12	OUTER DOOR PANEL 外板	20 GA. THK. SUS 304 S/S
✓ 13	INNER DOOR PANEL 内板	22 GA. THK. SUS 304 S/S
✓ 14	CABINET BODY 柜身	20 GA. THK. SUS 304 S/S
15	CORNER BUMPER 拐角防护套	COLSON (CHN)
16	SWIVEL CASTOR 旋转角轮	GLOBE (CHN)
17	SOUND DEADEN MATERIAL 隔音材料	3mm THICKNESS
18	WALL FLASHING 防水面	20 GA. THK. SUS 304 S/S
19	CONDENSING UNIT 制冷机组	DANFOSS (CHN)
20	NOZZLE 排气口	Ø25mm SUS 304 S/S TUBE

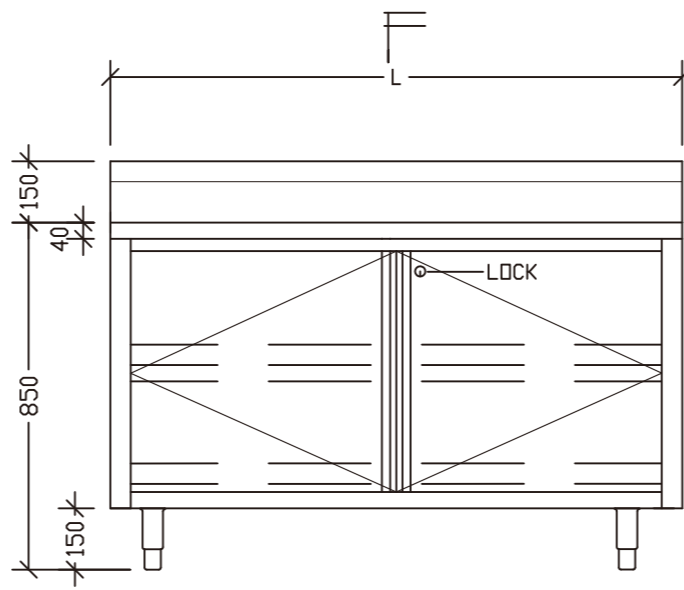

ELEVATION

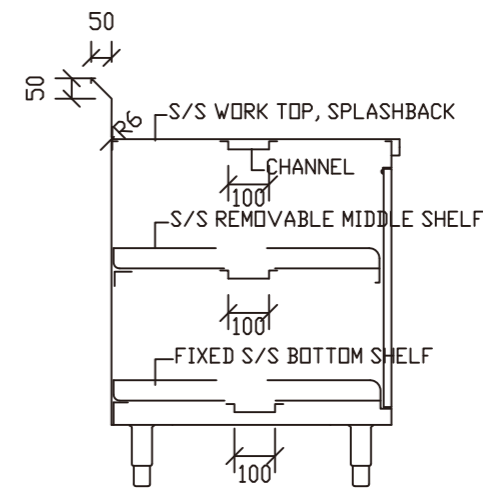

SECTION

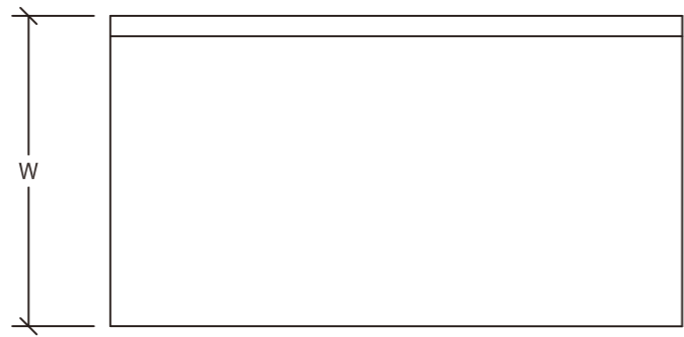

PLAN

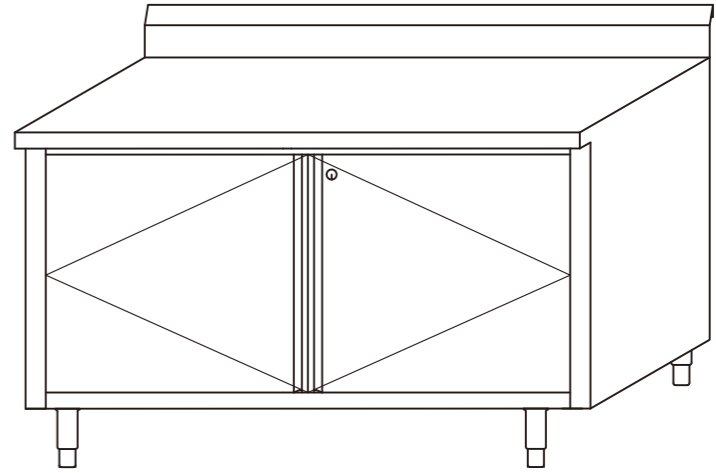

ISOMETRIC VIEW

No:	Item No(款号):	Qty(数量):	No:	Item No(款号):	Qty(数量):

Remark(备注):



SPOT WELDED A THREADED SHAFT TO THE UNDERSIDE OF WORK TOP / SHELF. THEN USE UNITS TO FIX WITH THE REINFORCEMENT / BRACKETS

技术说明:				SKU:			
1.所有产品边缘不能有毛刺, 覆膜面不能刮花;				名称:	建德C40+潜水俱乐部厨房		
2.公差要求标准: 符合GB/T G3280-2015不锈钢冷轧钢板和钢带标准中PT.A的公称宽度要求;				材料:			
3.所有标注尺寸为外尺寸;				编制:		日期:	
4.未注膜面方向朝外。				审核:		日期:	
A						视角:	☉
版本			批准	日期		版本:	A

STAINLESS STEEL SHOP DRAWING (CUSTOM)

不锈钢件生产要求图

Product Description (产品说明):	Work Cabinet
	工作掩门柜
Model Type (模具型号):	CBH Q15

No:	Parts(零部件):	Material Specification(用料标准):
✓ 01	COUNTER TOP	柜台面 16GA. THK. SUS 304 S/S
02	LEG	支腿 Ø38mm 16 GA. THK. SUS 304 S/S TUBE
✓ 03	ADJUSTABLE FOOT INSERT	可调节嵌入式底脚 LUI CHUEN KEE (CHN)
✓ 04	REINFORCEMENT	加固件 16 GA. THK. SUS 304 S/S
05	SINK BOWL	洗碗槽 16 GA. THK. SUS 304 S/S
06	SINK WASTE	废料槽
07	S.S. CROSS RAIL	横梁 Ø32mm 16 GA. THK. SUS 304 S/S TUBE
08	WALL MOUNTED BRACKET	壁装托架 16 GA. THK. SUS 304 S/S
✓ 09	UNDER SHELF	底架 18 GA. THK. SUS 304 S/S
10	MIXING FAUCET	混合龙头
11	OVER SHELF	顶架 18 GA. THK. SUS 304 S/S
✓ 12	OUTER DOOR PANEL	外板 20 GA. THK. SUS 304 S/S
✓ 13	INNER DOOR PANEL	内板 22 GA. THK. SUS 304 S/S
✓ 14	CABINET BODY	柜身 20 GA. THK. SUS 304 S/S
15	CORNER BUMPER	拐角防护套 COLSON (CHN)
16	SWIVEL CASTOR	旋转角轮 GLOBE (CHN)
17	SOUND DEADEN MATERIAL	隔音材料 3mm THICKNESS
18	WALL FLASHING	防水面 20 GA. THK. SUS 304 S/S
19	CONDENSING UNIT	制冷机组 DANFOSS (CHN)
20	NOZZLE	排气口 Ø25mm SUS 304 S/S TUBE

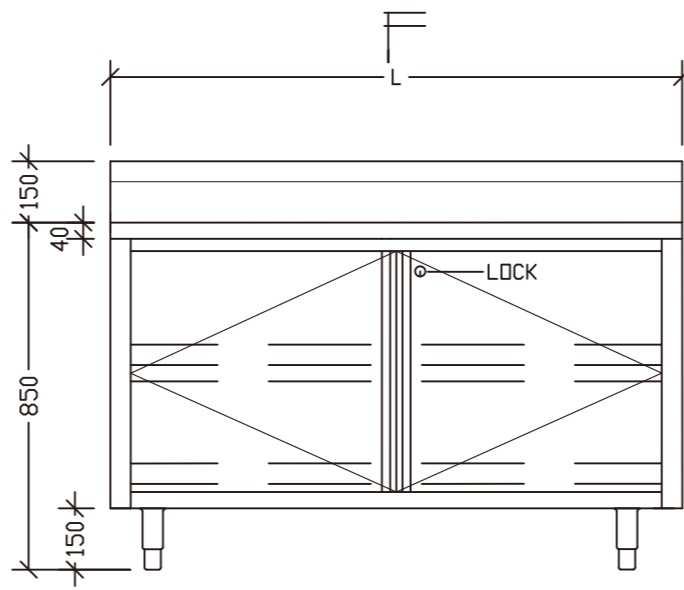

ELEVATION

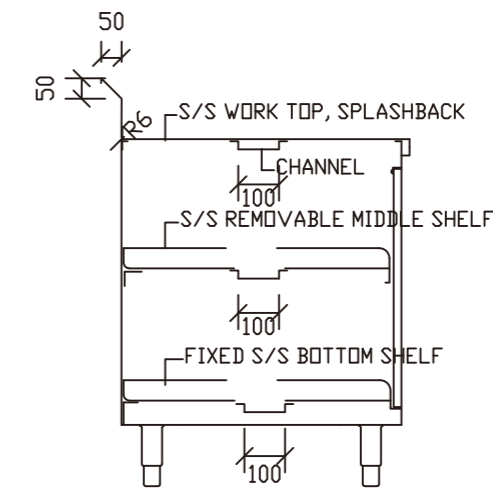

SECTION

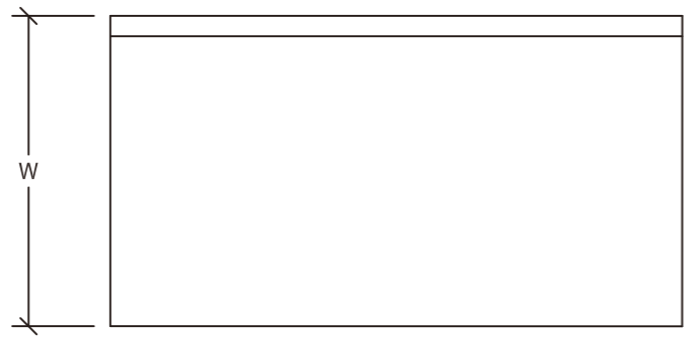

PLAN

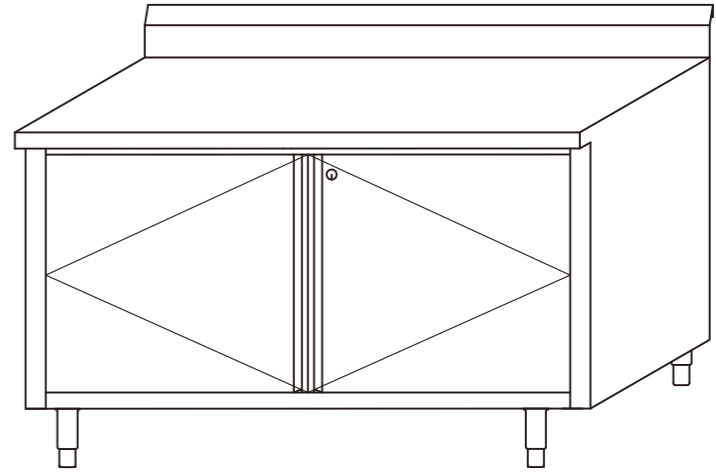

ISOMETRIC VIEW

No:	Item No(款号):	Qty(数量):	No:	Item No(款号):	Qty(数量):

Remark(备注):



SPOT WELDED A THREADED SHAFT TO THE UNDERSIDE OF WORK TOP / SHELF. THEN USE UNITS TO FIX WITH THE REINFORCEMENT / BRACKETS

技术说明:				SKU:			
1.所有产品边缘不能有毛刺, 覆膜面不能刮花;				名称:	建德C40+潜水俱乐部厨房		
2.公差要求标准: 符合GB/T G3280-2015不锈钢冷轧钢板和钢带标准中PT.A的公称宽度要求;				材料:			
3.所有标注尺寸为外尺寸;				编制:		日期:	
4.未注膜面方向朝外。				审核:		日期:	
A						视角:	☉ ☒
版本			批准	日期		版本:	A

STAINLESS STEEL SHOP DRAWING (CUSTOM)

不锈钢件生产要求图

Product Description (产品说明):	Work Table W/Twin Sinks
	工作台连双星盆 (中间去水)
Model Type (模具型号):	STSH1 Q16

No:	Parts(零部件):	Material Specification(用料标准):
✓ 01	COUNTER TOP 柜台面	16GA. THK. SUS 304 S/S
✓ 02	LEG 支腿	∅38mm 16 GA. THK. SUS 304 S/S TUBE
✓ 03	ADJUSTABLE FOOT INSERT 可调节嵌入式底脚	LUI CHUEN KEE (CHN)
✓ 04	REINFORCEMENT 加固件	16 GA. THK. SUS 304 S/S
✓ 05	SINK BOWL 洗碗槽	16 GA. THK. SUS 304 S/S
06	SINK WASTE 废料槽	
✓ 07	S.S. CROSS RAIL 横梁	∅32mm 16 GA. THK. SUS 304 S/S TUBE
08	WALL MOUNTED BRACKET 壁装托架	16 GA. THK. SUS 304 S/S
09	UNDER SHELF 底架	18 GA. THK. SUS 304 S/S
✓ 10	MIXING FAUCET 混合龙头	
11	OVER SHELF 顶架	18 GA. THK. SUS 304 S/S
12	OUTER DOOR PANEL 外板	20 GA. THK. SUS 304 S/S
13	INNER DOOR PANEL 内板	22 GA. THK. SUS 304 S/S
14	CABINET BODY 柜身	20 GA. THK. SUS 304 S/S
15	CORNER BUMPER 拐角防护套	COLSON (CHN)
16	SWIVEL CASTOR 旋转角轮	GLOBE (CHN)
17	SOUND DEADEN MATERIAL 隔音材料	3mm THICKNESS
18	WALL FLASHING 防水面	20 GA. THK. SUS 304 S/S
19	CONDENSING UNIT 制冷机组	DANFOSS (CHN)
20	NOZZLE 排气口	∅25mm SUS 304 S/S TUBE

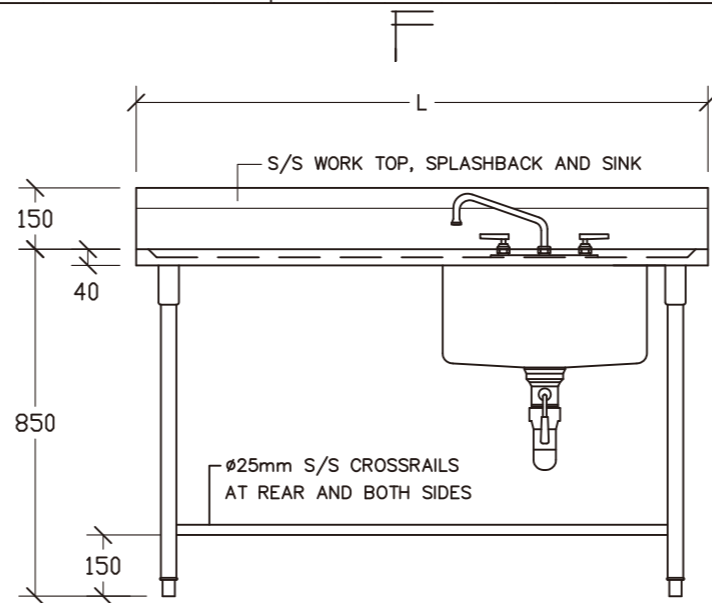

ELEVATION

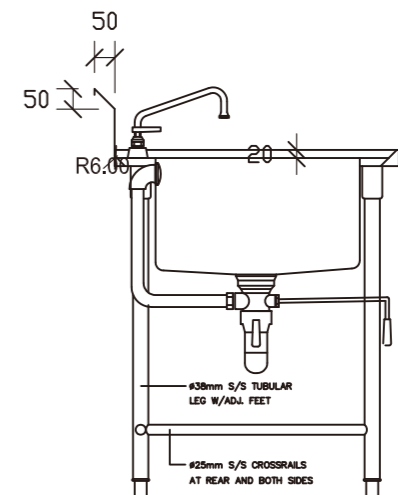

SECTION

No:	Item No(款号):	Qty(数量):	No:	Item No(款号):	Qty(数量):

Remark(备注):

 SPOT WELDED A THREADED SHAFT TO THE UNDERSIDE OF WORK TOP / SHELF. THEN USE UNITS TO FIX WITH THE REINFORCEMENT / BRACKETS

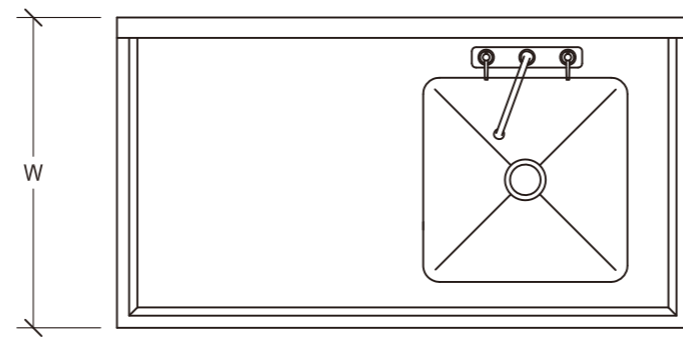

PLAN

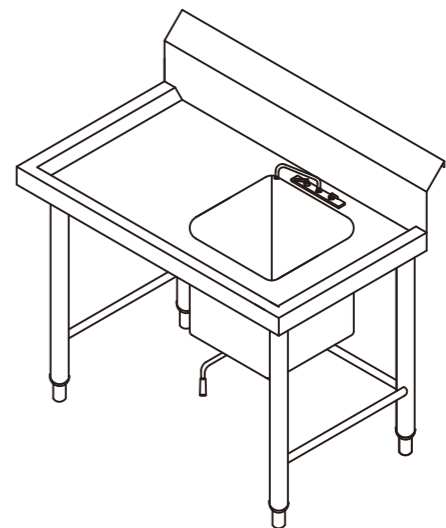

ISOMETRIC VIEW

技术说明:				SKU:			
1.所有产品边缘不能有毛刺, 覆膜面不能刮花;				名称:	建德C40+潜水俱乐部厨房		
2.公差要求标准: 符合GB/T G3280-2015不锈钢冷轧钢板和钢带标准中PT.A的公称宽度要求;				材料:			
3.所有标注尺寸为外尺寸;				编制:		日期:	
4.未注膜面方向朝外。				审核:		日期:	
A						视角:	
版本		批准	日期			版本:	A

STAINLESS STEEL SHOP DRAWING (CUSTOM)

不锈钢件生产要求图

Product Description (产品说明):	Single Wall Mounted Shelving
	单层挂墙层架
Model Type (模具型号):	JBW1 Q17

No:	Parts(零部件):	Material Specification(用料标准):
01	COUNTER TOP 柜台面	16GA. THK. SUS 304 S/S
02	LEG 支腿	∅38mm 16 GA. THK. SUS 304 S/S TUBE
03	ADJUSTABLE FOOT INSERT 可调节嵌入式底脚	LUI CHUEN KEE (CHN)
✓ 04	REINFORCEMENT 加固件	16 GA. THK. SUS 304 S/S
05	SINK BOWL 洗碗槽	16 GA. THK. SUS 304 S/S
06	SINK WASTE 废料槽	
07	S.S. CROSS RAIL 横梁	∅32mm 16 GA. THK. SUS 304 S/S TUBE
✓ 08	WALL MOUNTED BRACKET 壁装托架	16 GA. THK. SUS 304 S/S
09	UNDER SHELF 底架	18 GA. THK. SUS 304 S/S
10	MIXING FAUCET 混合龙头	
✓ 11	OVER SHELF 顶架	18 GA. THK. SUS 304 S/S
12	OUTER DOOR PANEL 外板	20 GA. THK. SUS 304 S/S
13	INNER DOOR PANEL 内板	22 GA. THK. SUS 304 S/S
14	CABINET BODY 柜身	20 GA. THK. SUS 304 S/S
15	CORNER BUMPER 拐角防护套	COLSON (CHN)
16	SWIVEL CASTOR 旋转角轮	GLOBE (CHN)
17	SOUND DEADEN MATERIAL 隔音材料	3mm THICKNESS
18	WALL FLASHING 防水面	20 GA. THK. SUS 304 S/S
19	CONDENSING UNIT 制冷机组	DANFOSS (CHN)
20	NOZZLE 排气口	∅25mm SUS 304 S/S TUBE

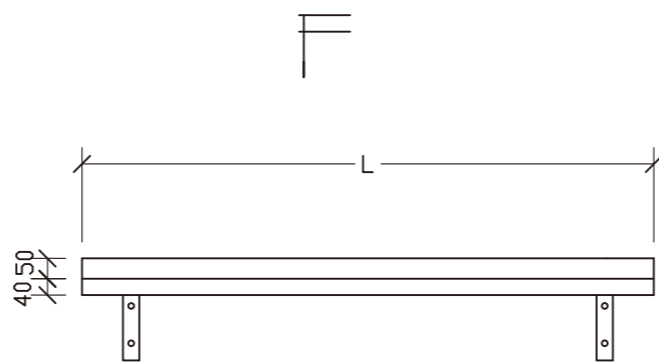

ELEVATION

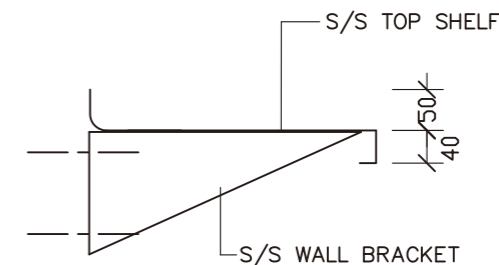

SECTION

No:	Item No(款号):	Qty(数量):	No:	Item No(款号):	Qty(数量):

Remark(备注):



SPOT WELDED A THREADED SHAFT TO THE UNDERSIDE OF WORK TOP / SHELF. THEN USE UNITS TO FIX WITH THE REINFORCEMENT / BRACKETS



PLAN

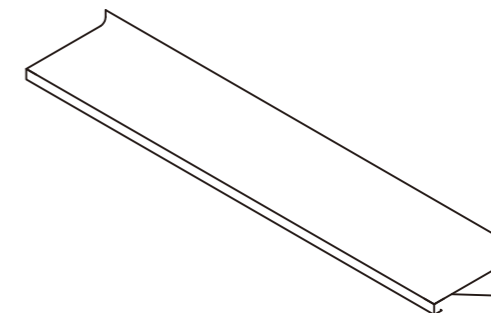

ISOMETRIC VIEW

技术说明:				SKU:			
1.所有产品边缘不能有毛刺, 覆膜面不能刮花;				名称:	建德C40+潜水俱乐部厨房		
2.公差要求标准: 符合GB/T G3280-2015不锈钢冷轧钢板和钢带标准中PT.A的公称宽度要求;				材料:			
3.所有标注尺寸为外尺寸;				编制:		日期:	
4.未注膜面方向朝外。				审核:		日期:	
A						视角:	☉
版本		批准	日期			版本:	A

STAINLESS STEEL SHOP DRAWING (CUSTOM)

不锈钢件生产要求图

Product Description (产品说明):	4-Tier Square Tube Storage Shelving
	四层通架
Model Type (模具型号):	JFG4 R01

No:	Parts(零部件):	Material Specification(用料标准):
01	COUNTER TOP 柜台面	16GA. THK. SUS 304 S/S
✓ 02	LEG 支腿	∅38mm 16 GA. THK. SUS 304 S/S TUBE
✓ 03	ADJUSTABLE FOOT INSERT 可调节嵌入式底脚	LUI CHUEN KEE (CHN)
04	REINFORCEMENT 加固件	16 GA. THK. SUS 304 S/S
05	SINK BOWL 洗碗槽	16 GA. THK. SUS 304 S/S
06	SINK WASTE 废料槽	
✓ 07	S.S. CROSS RAIL 横梁	∅32mm 16 GA. THK. SUS 304 S/S TUBE
08	WALL MOUNTED BRACKET 壁装托架	16 GA. THK. SUS 304 S/S
09	UNDER SHELF 底架	18 GA. THK. SUS 304 S/S
10	MIXING FAUCET 混合龙头	
11	OVER SHELF 顶架	18 GA. THK. SUS 304 S/S
12	OUTER DOOR PANEL 外板	20 GA. THK. SUS 304 S/S
13	INNER DOOR PANEL 内板	22 GA. THK. SUS 304 S/S
14	CABINET BODY 柜身	20 GA. THK. SUS 304 S/S
15	CORNER BUMPER 拐角防护套	COLSON (CHN)
16	SWIVEL CASTOR 旋转角轮	GLOBE (CHN)
17	SOUND DEADEN MATERIAL 隔音材料	3mm THICKNESS
18	WALL FLASHING 防水面	20 GA. THK. SUS 304 S/S
19	CONDENSING UNIT 制冷机组	DANFOSS (CHN)
20	NOZZLE 排气口	∅25mm SUS 304 S/S TUBE

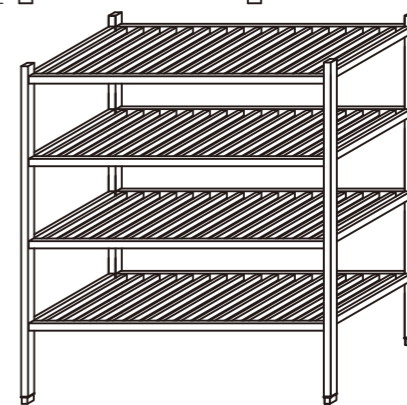
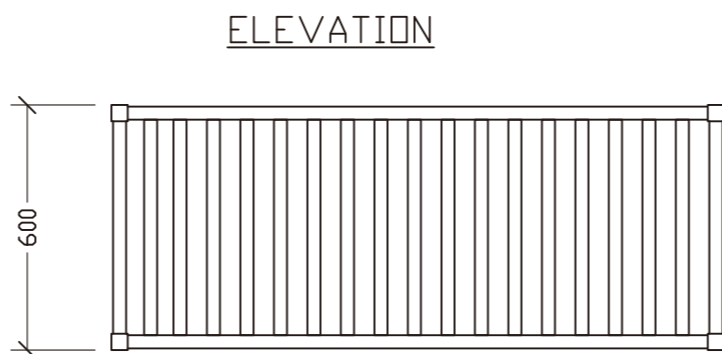
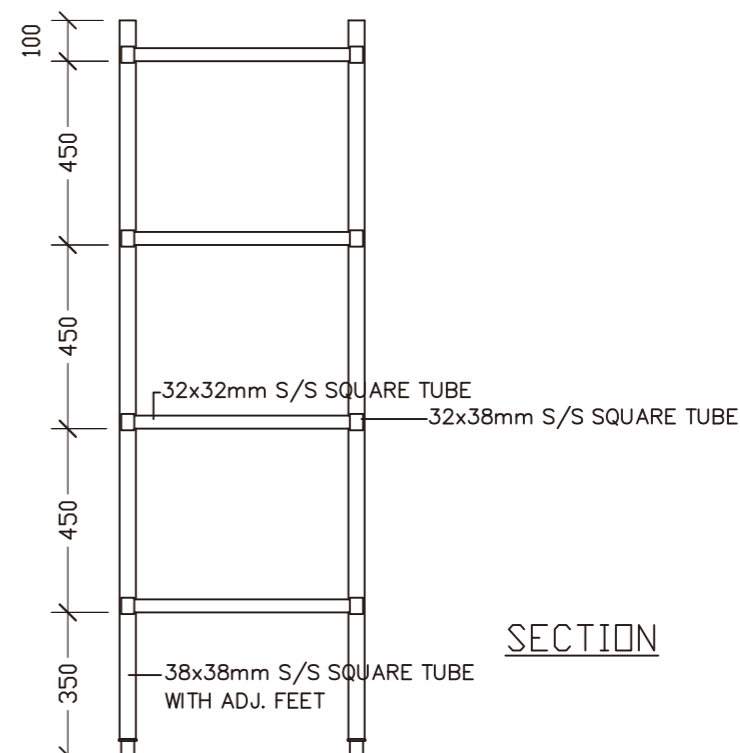
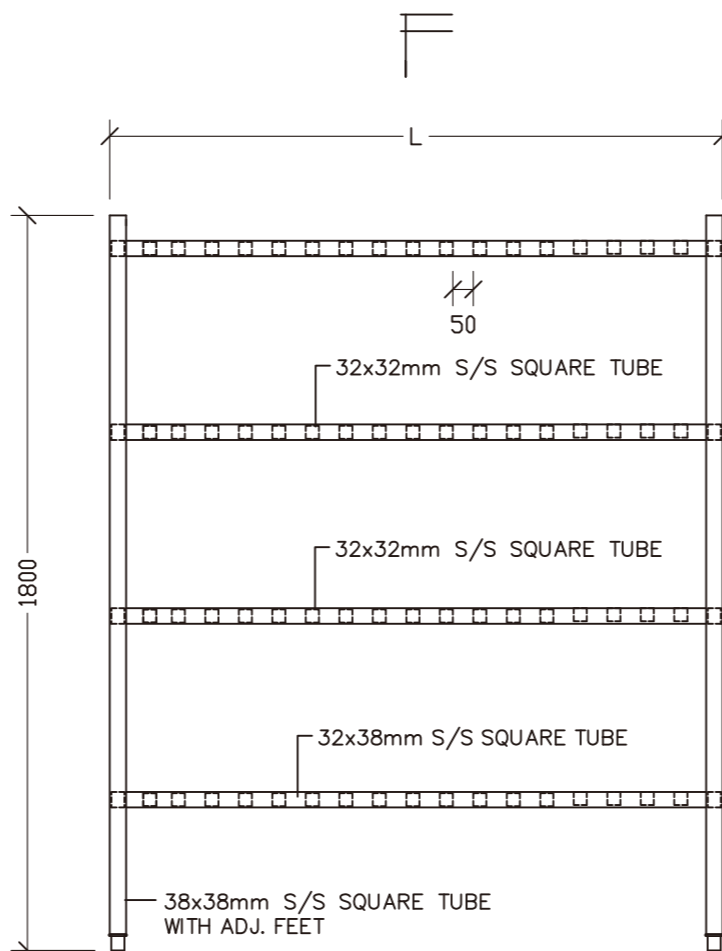

No:	Item No(款号):	Qty(数量):	No:	Item No(款号):	Qty(数量):

Remark(备注):



SPOT WELDED A THREADED SHAFT TO THE UNDERSIDE OF WORK TOP / SHELF. THEN USE UNITS TO FIX WITH THE REINFORCEMENT / BRACKETS

技术说明:
 1.所有产品边缘不能有毛刺, 覆膜面不能刮花;
 2.公差要求标准: 符合GB/T G3280-2015不锈钢冷轧钢板和钢带标准中PT.A的公称宽度要求;
 3.所有标注尺寸为外尺寸;
 4.未注膜面方向朝外。

SKU:
 名称: 建德C40+潜水俱乐部厨房
 材料:
 编制:
 审核:

日期:
 日期:
 视角:
 版本: A

STAINLESS STEEL SHOP DRAWING (CUSTOM)

不锈钢件生产要求图

Product Description (产品说明):	Work Table W/Under Shelf
	工作台下置层板
Model Type (模具型号):	TBS1 R02

No:	Parts(零部件):	Material Specification(用料标准):
✓ 01	COUNTER TOP 柜台面	16GA. THK. SUS 304 S/S
✓ 02	LEG 支腿	Ø38mm 16 GA. THK. SUS 304 S/S TUBE
✓ 03	ADJUSTABLE FOOT INSERT 可调节嵌入式底脚	LUI CHUEN KEE (CHN)
✓ 04	REINFORCEMENT 加固件	16 GA. THK. SUS 304 S/S
05	SINK BOWL 洗碗槽	16 GA. THK. SUS 304 S/S
06	SINK WASTE 废料槽	
✓ 07	S.S. CROSS RAIL 横梁	Ø32mm 16 GA. THK. SUS 304 S/S TUBE
08	WALL MOUNTED BRACKET 壁装托架	16 GA. THK. SUS 304 S/S
09	UNDER SHELF 底架	18 GA. THK. SUS 304 S/S
10	MIXING FAUCET 混合龙头	
11	OVER SHELF 顶架	18 GA. THK. SUS 304 S/S
12	OUTER DOOR PANEL 外板	20 GA. THK. SUS 304 S/S
13	INNER DOOR PANEL 内板	22 GA. THK. SUS 304 S/S
14	CABINET BODY 柜身	20 GA. THK. SUS 304 S/S
15	CORNER BUMPER 拐角防护套	COLSON (CHN)
16	SWIVEL CASTOR 旋转角轮	GLOBE (CHN)
17	SOUND DEADEN MATERIAL 隔音材料	3mm THICKNESS
18	WALL FLASHING 防水面	20 GA. THK. SUS 304 S/S
19	CONDENSING UNIT 制冷机组	DANFOSS (CHN)
20	NOZZLE 排气口	Ø25mm SUS 304 S/S TUBE

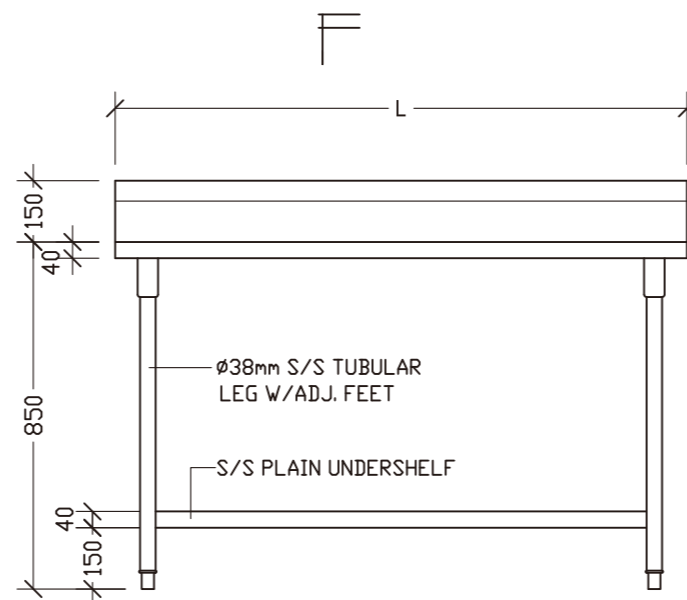

ELEVATION

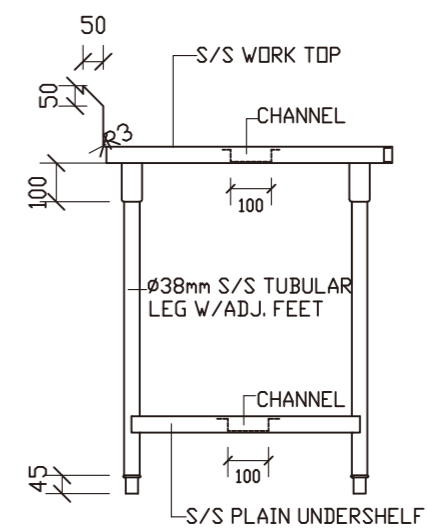

SECTION

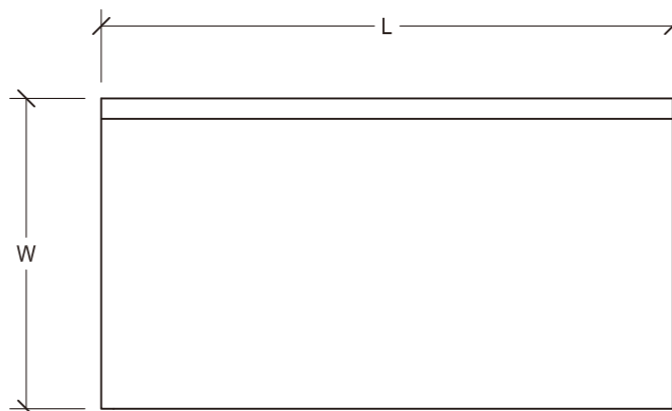

PLAN

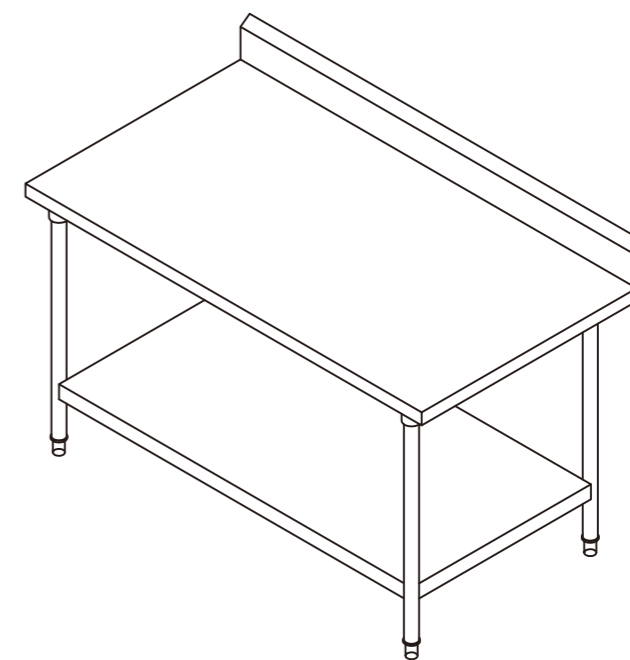

ISOMETRIC VIEW

No:	Item No(款号):	Qty(数量):	No:	Item No(款号):	Qty(数量):

Remark(备注):



SPOT WELDED A THREADED SHAFT TO THE UNDERSIDE OF WORK TOP / SHELF. THEN USE UNITS TO FIX WITH THE REINFORCEMENT / BRACKETS

技术说明:
 1.所有产品边缘不能有毛刺, 覆膜面不能刮花;
 2.公差要求标准: 符合GB/T G3280-2015不锈钢冷轧钢板和钢带标准中PT.A的公称宽度要求;
 3.所有标注尺寸为外尺寸;
 4.未注膜面方向朝外。

SKU:		日期:		视角:	☉ ☒
名称:	建德C40+潜水俱乐部厨房	日期:		版本:	A
材料:					
编制:					
审核:					

A					
版本			批准	日期	

STAINLESS STEEL SHOP DRAWING (CUSTOM)

不锈钢件生产要求图

Product Description (产品说明):	Work Table W/Under Shelf
	工作台下置层板
Model Type (模具型号):	TBS1 R03

No:	Parts(零部件):	Material Specification(用料标准):
✓ 01	COUNTER TOP 柜台面	16GA. THK. SUS 304 S/S
✓ 02	LEG 支腿	Ø38mm 16 GA. THK. SUS 304 S/S TUBE
✓ 03	ADJUSTABLE FOOT INSERT 可调节嵌入式底脚	LUI CHUEN KEE (CHN)
✓ 04	REINFORCEMENT 加固件	16 GA. THK. SUS 304 S/S
05	SINK BOWL 洗碗槽	16 GA. THK. SUS 304 S/S
06	SINK WASTE 废料槽	
✓ 07	S.S. CROSS RAIL 横梁	Ø32mm 16 GA. THK. SUS 304 S/S TUBE
08	WALL MOUNTED BRACKET 壁挂托架	16 GA. THK. SUS 304 S/S
09	UNDER SHELF 底架	18 GA. THK. SUS 304 S/S
10	MIXING FAUCET 混合龙头	
11	OVER SHELF 顶架	18 GA. THK. SUS 304 S/S
12	OUTER DOOR PANEL 外板	20 GA. THK. SUS 304 S/S
13	INNER DOOR PANEL 内板	22 GA. THK. SUS 304 S/S
14	CABINET BODY 柜身	20 GA. THK. SUS 304 S/S
15	CORNER BUMPER 拐角防护套	COLSON (CHN)
16	SWIVEL CASTOR 旋转角轮	GLOBE (CHN)
17	SOUND DEADEN MATERIAL 隔音材料	3mm THICKNESS
18	WALL FLASHING 防水面	20 GA. THK. SUS 304 S/S
19	CONDENSING UNIT 制冷机组	DANFOSS (CHN)
20	NOZZLE 排气口	Ø25mm SUS 304 S/S TUBE

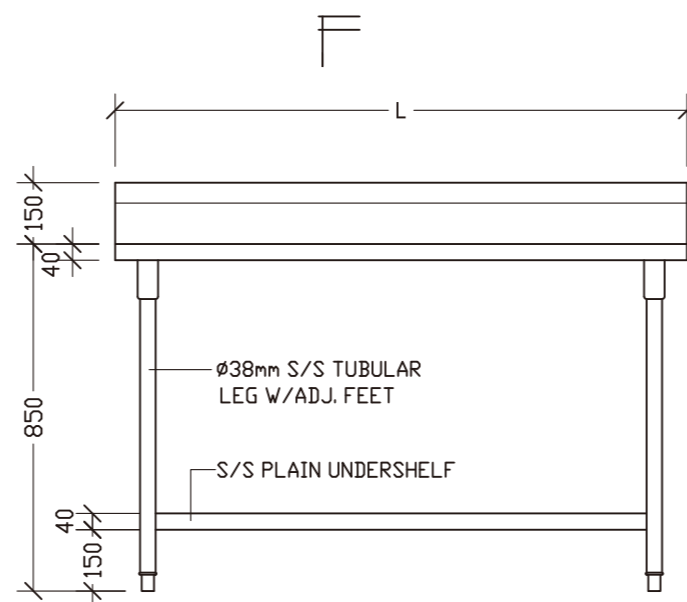

ELEVATION

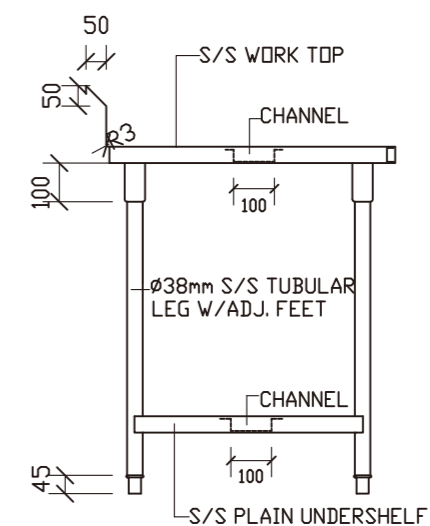

SECTION

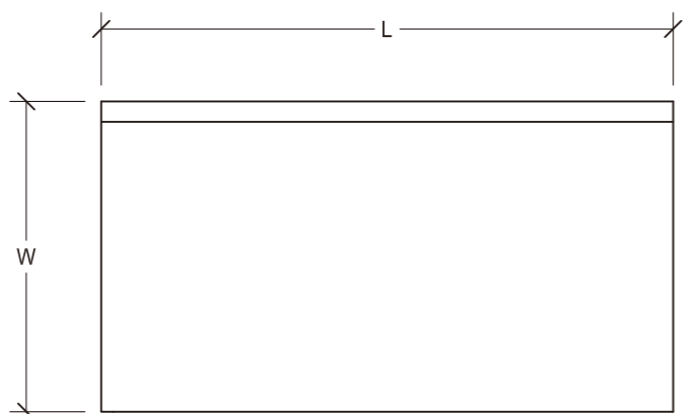

PLAN

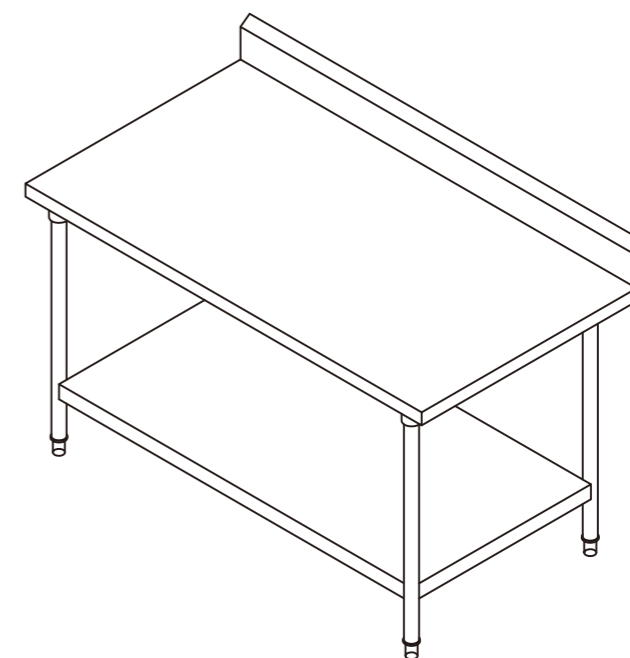

ISOMETRIC VIEW

No:	Item No(款号):	Qty(数量):	No:	Item No(款号):	Qty(数量):

Remark(备注):



SPOT WELDED A THREADED SHAFT TO THE UNDERSIDE OF WORK TOP / SHELF. THEN USE UNITS TO FIX WITH THE REINFORCEMENT / BRACKETS

技术说明:				SKU:			
1.所有产品边缘不能有毛刺, 覆膜面不能刮花;				名称:	建德C40+潜水俱乐部厨房		
2.公差要求标准: 符合GB/T G3280-2015不锈钢冷轧钢板和钢带标准中PT.A的公称宽度要求;				材料:			
3.所有标注尺寸为外尺寸;				编制:		日期:	
4.未注膜面方向朝外。				审核:		日期:	
A						视角:	☉
版本			批准	日期		版本:	A

STAINLESS STEEL SHOP DRAWING (CUSTOM)

不锈钢件生产要求图

Product Description (产品说明):	Double Ceiling Mounted Shelving
	吊天花双层架
Model Type (模具型号):	JBC2 R06

No:	Parts(零部件):	Material Specification(用料标准):
01	COUNTER TOP 柜台面	16GA. THK. SUS 304 S/S
✓ 02	LEG 支腿	∅38mm 16 GA. THK. SUS 304 S/S TUBE
03	ADJUSTABLE FOOT INSERT 可调节嵌入式底脚	LUI CHUEN KEE (CHN)
✓ 04	REINFORCEMENT 加固件	16 GA. THK. SUS 304 S/S
05	SINK BOWL 洗碗槽	16 GA. THK. SUS 304 S/S
06	SINK WASTE 废料槽	
07	S.S. CROSS RAIL 横梁	∅32mm 16 GA. THK. SUS 304 S/S TUBE
08	WALL MOUNTED BRACKET 壁装托架	16 GA. THK. SUS 304 S/S
09	UNDER SHELF 底架	18 GA. THK. SUS 304 S/S
10	MIXING FAUCET 混合龙头	
✓ 11	OVER SHELF 顶架	18 GA. THK. SUS 304 S/S
12	OUTER DOOR PANEL 外板	20 GA. THK. SUS 304 S/S
13	INNER DOOR PANEL 内板	22 GA. THK. SUS 304 S/S
14	CABINET BODY 柜身	20 GA. THK. SUS 304 S/S
15	CORNER BUMPER 拐角防护套	COLSON (CHN)
16	SWIVEL CASTOR 旋转角轮	GLOBE (CHN)
17	SOUND DEADEN MATERIAL 隔音材料	3mm THICKNESS
18	WALL FLASHING 防水面	20 GA. THK. SUS 304 S/S
19	CONDENSING UNIT 制冷机组	DANFOSS (CHN)
20	NOZZLE 排气口	∅25mm SUS 304 S/S TUBE

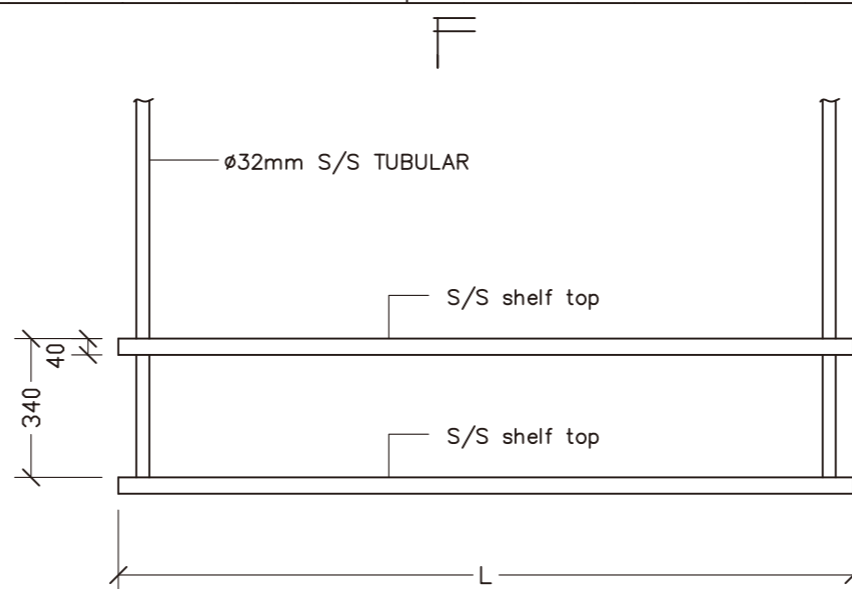

ELEVATION

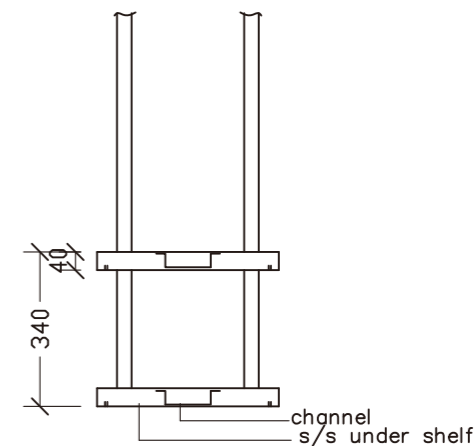

SECTION

No:	Item No(款号):	Qty(数量):	No:	Item No(款号):	Qty(数量):

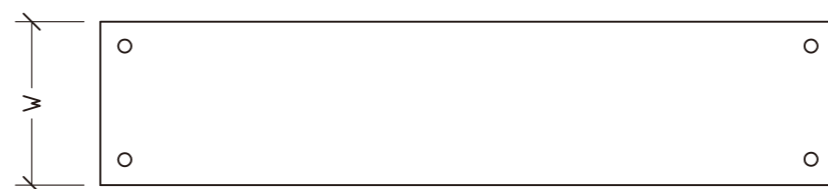

PLAN

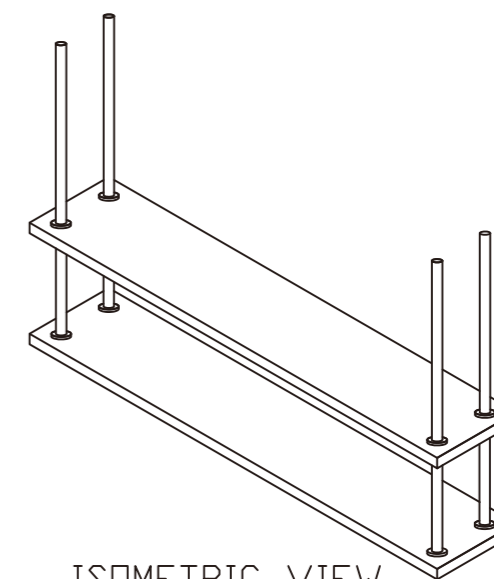

ISOMETRIC VIEW

Remark(备注):



SPOT WELDED A THREADED SHAFT TO THE UNDERSIDE OF WORK TOP / SHELF. THEN USE UNITS TO FIX WITH THE REINFORCEMENT / BRACKETS

技术说明:				SKU:			
1.所有产品边缘不能有毛刺, 覆膜面不能刮花;				名称:	建德C40+潜水俱乐部厨房		
2.公差要求标准: 符合GB/T G3280-2015不锈钢冷轧钢板和钢带标准中PT.A的公称宽度要求;				材料:			
3.所有标注尺寸为外尺寸;				编制:		日期:	
4.未注膜面方向朝外。				审核:		日期:	
A						视角:	☉
版本		批准	日期			版本:	A

STAINLESS STEEL SHOP DRAWING (CUSTOM)

不锈钢件生产要求图

Product Description (产品说明):	Double Ceiling Mounted Shelving
	吊天花双层架
Model Type (模具型号):	JBC2 R07

No:	Parts(零部件):	Material Specification(用料标准):
01	COUNTER TOP 柜台面	16GA. THK. SUS 304 S/S
✓ 02	LEG 支腿	∅38mm 16 GA. THK. SUS 304 S/S TUBE
03	ADJUSTABLE FOOT INSERT 可调节嵌入式底脚	LUI CHUEN KEE (CHN)
✓ 04	REINFORCEMENT 加固件	16 GA. THK. SUS 304 S/S
05	SINK BOWL 洗碗槽	16 GA. THK. SUS 304 S/S
06	SINK WASTE 废料槽	
07	S.S. CROSS RAIL 横梁	∅32mm 16 GA. THK. SUS 304 S/S TUBE
08	WALL MOUNTED BRACKET 壁装托架	16 GA. THK. SUS 304 S/S
09	UNDER SHELF 底架	18 GA. THK. SUS 304 S/S
10	MIXING FAUCET 混合龙头	
✓ 11	OVER SHELF 顶架	18 GA. THK. SUS 304 S/S
12	OUTER DOOR PANEL 外板	20 GA. THK. SUS 304 S/S
13	INNER DOOR PANEL 内板	22 GA. THK. SUS 304 S/S
14	CABINET BODY 柜身	20 GA. THK. SUS 304 S/S
15	CORNER BUMPER 拐角防护套	COLSON (CHN)
16	SWIVEL CASTOR 旋转角轮	GLOBE (CHN)
17	SOUND DEADEN MATERIAL 隔音材料	3mm THICKNESS
18	WALL FLASHING 防水面	20 GA. THK. SUS 304 S/S
19	CONDENSING UNIT 制冷机组	DANFOSS (CHN)
20	NOZZLE 排气口	∅25mm SUS 304 S/S TUBE

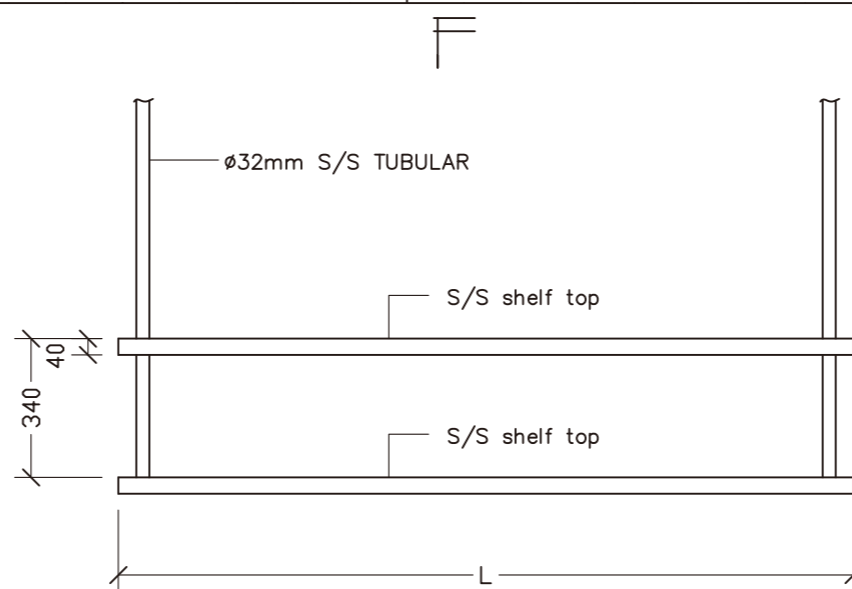

ELEVATION

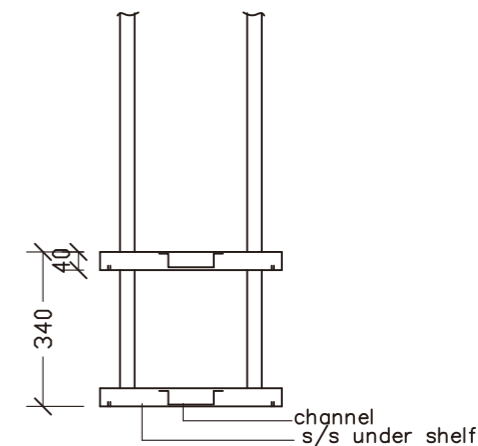

SECTION

No:	Item No(款号):	Qty(数量):	No:	Item No(款号):	Qty(数量):

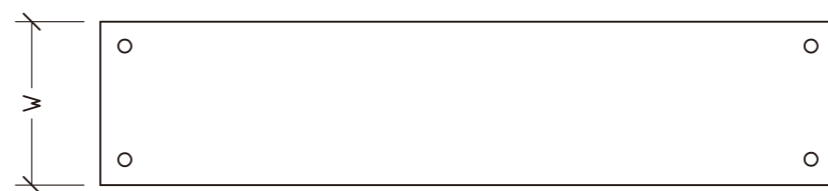

PLAN

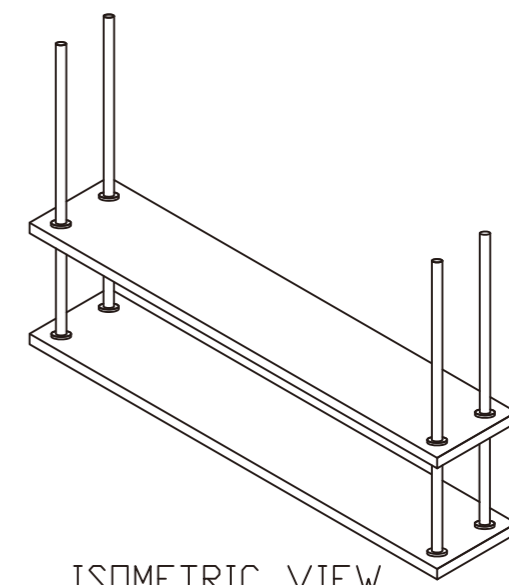

ISOMETRIC VIEW

Remark(备注):	
 M5	SPOT WELDED A THREADED SHAFT TO THE UNDERSIDE OF WORK TOP / SHELF. THEN USE UNITS TO FIX WITH THE REINFORCEMENT / BRACKETS

技术说明:				SKU:			
1.所有产品边缘不能有毛刺, 覆膜面不能刮花;				名称:	建德C40+潜水俱乐部厨房		
2.公差要求标准: 符合GB/T G3280-2015不锈钢冷轧钢板和钢带标准中PT.A的公称宽度要求;				材料:			
3.所有标注尺寸为外尺寸;				编制:		日期:	
4.未注膜面方向朝外。				审核:		日期:	
A						视角:	☉
版本		批准	日期			版本:	A

STAINLESS STEEL SHOP DRAWING (CUSTOM)

不锈钢件生产要求图

Product Description (产品说明):	Work Table W/Twin Sinks
	工作台连双星盆 (中间去水)
Model Type (模具型号):	STSH2 R08

No:	Parts(零部件):	Material Specification(用料标准):
✓ 01	COUNTER TOP 柜台面	16GA. THK. SUS 304 S/S
✓ 02	LEG 支腿	∅38mm 16 GA. THK. SUS 304 S/S TUBE
✓ 03	ADJUSTABLE FOOT INSERT 可调节嵌入式底脚	LUI CHUEN KEE (CHN)
✓ 04	REINFORCEMENT 加固件	16 GA. THK. SUS 304 S/S
✓ 05	SINK BOWL 洗碗槽	16 GA. THK. SUS 304 S/S
06	SINK WASTE 废料槽	
✓ 07	S.S. CROSS RAIL 横梁	∅32mm 16 GA. THK. SUS 304 S/S TUBE
08	WALL MOUNTED BRACKET 壁装托架	16 GA. THK. SUS 304 S/S
09	UNDER SHELF 底架	18 GA. THK. SUS 304 S/S
✓ 10	MIXING FAUCET 混合龙头	
11	OVER SHELF 顶架	18 GA. THK. SUS 304 S/S
12	OUTER DOOR PANEL 外板	20 GA. THK. SUS 304 S/S
13	INNER DOOR PANEL 内板	22 GA. THK. SUS 304 S/S
14	CABINET BODY 柜身	20 GA. THK. SUS 304 S/S
15	CORNER BUMPER 拐角防护套	COLSON (CHN)
16	SWIVEL CASTOR 旋转角轮	GLOBE (CHN)
17	SOUND DEADEN MATERIAL 隔音材料	3mm THICKNESS
18	WALL FLASHING 防水面	20 GA. THK. SUS 304 S/S
19	CONDENSING UNIT 制冷机组	DANFOSS (CHN)
20	NOZZLE 排气口	∅25mm SUS 304 S/S TUBE

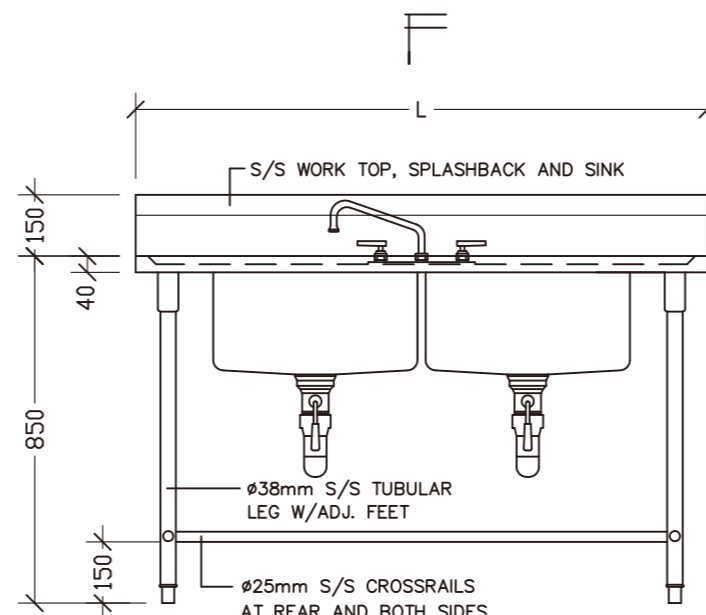

ELEVATION

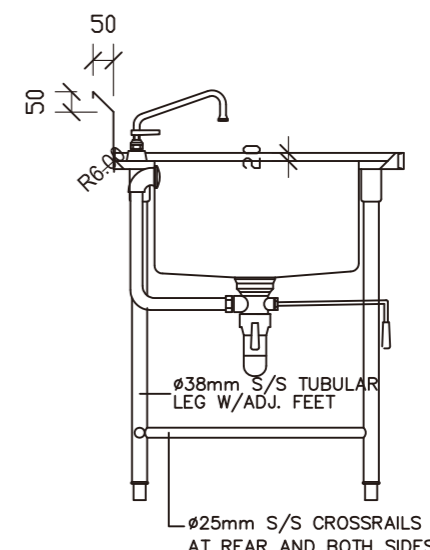

SECTION

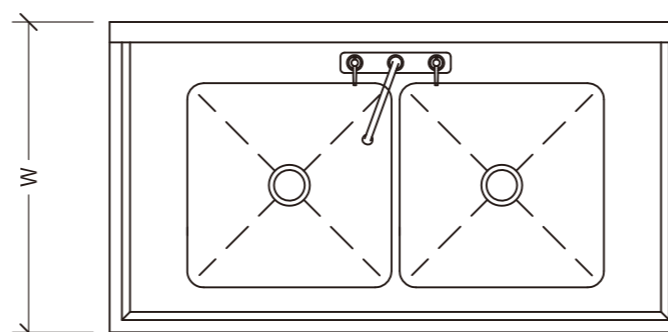

PLAN

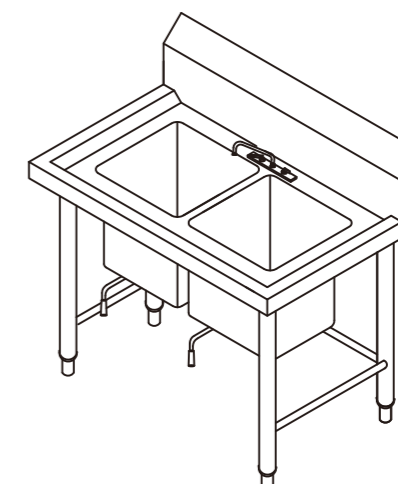

ISOMETRIC VIEW

No:	Item No(款号):	Qty(数量):	No:	Item No(款号):	Qty(数量):

Remark(备注):



SPOT WELDED A THREADED SHAFT TO THE UNDERSIDE OF WORK TOP / SHELF. THEN USE UNITS TO FIX WITH THE REINFORCEMENT / BRACKETS

技术说明:				SKU:			
1.所有产品边缘不能有毛刺, 覆膜面不能刮花;				名称:	建德C40+潜水俱乐部厨房		
2.公差要求标准: 符合GB/T G3280-2015不锈钢冷轧钢板和钢带标准中PT.A的公称宽度要求;				材料:			
3.所有标注尺寸为外尺寸;				编制:		日期:	
4.未注膜面方向朝外。				审核:		日期:	
A						视角:	☉
版本		批准	日期			版本:	A

STAINLESS STEEL SHOP DRAWING (CUSTOM)

不锈钢件生产要求图

Product Description (产品说明):	Work Table W/Under Shelf
	调料平台
Model Type (模具型号):	TBS1 R12

No:	Parts(零部件):	Material Specfication(用料标准):
✓ 01	COUNTER TOP 柜台面	16GA. THK. SUS 304 S/S
✓ 02	LEG 支腿	Ø38mm 16 GA. THK. SUS 304 S/S TUBE
✓ 03	ADJUSTABLE FOOT INSERT 可调节嵌入式底脚	LUI CHUEN KEE (CHN)
✓ 04	REINFORCEMENT 加固件	16 GA. THK. SUS 304 S/S
05	SINK BOWL 洗碗槽	16 GA. THK. SUS 304 S/S
06	SINK WASTE 废料槽	
✓ 07	S.S. CROSS RAIL 横梁	Ø32mm 16 GA. THK. SUS 304 S/S TUBE
08	WALL MOUNTED BRACKET 壁挂托架	16 GA. THK. SUS 304 S/S
09	UNDER SHELF 底架	18 GA. THK. SUS 304 S/S
10	MIXING FAUCET 混合龙头	
11	OVER SHELF 顶架	18 GA. THK. SUS 304 S/S
12	OUTER DOOR PANEL 外板	20 GA. THK. SUS 304 S/S
13	INNER DOOR PANEL 内板	22 GA. THK. SUS 304 S/S
14	CABINET BODY 柜身	20 GA. THK. SUS 304 S/S
15	CORNER BUMPER 拐角防护套	COLSON (CHN)
16	SWIVEL CASTOR 旋转角轮	GLOBE (CHN)
17	SOUND DEADEN MATERIAL 隔音材料	3mm THICKNESS
18	WALL FLASHING 防水面	20 GA. THK. SUS 304 S/S
19	CONDENSING UNIT 制冷机组	DANFOSS (CHN)
20	NOZZLE 排气口	Ø25mm SUS 304 S/S TUBE

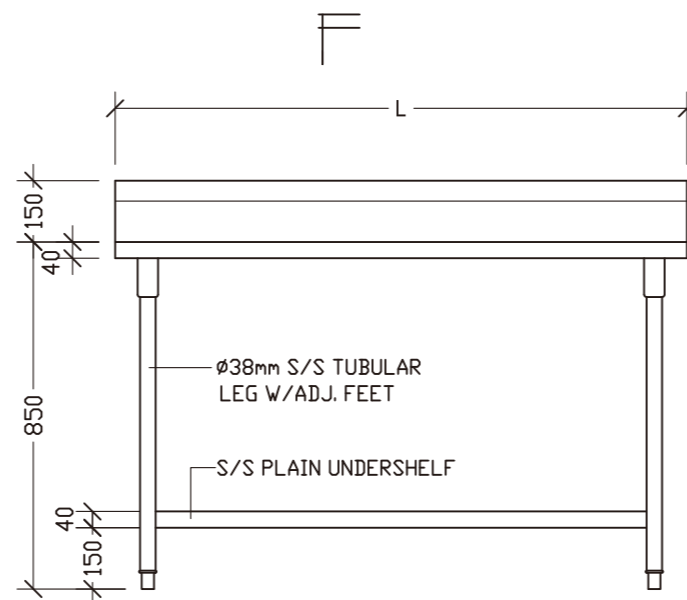

ELEVATION

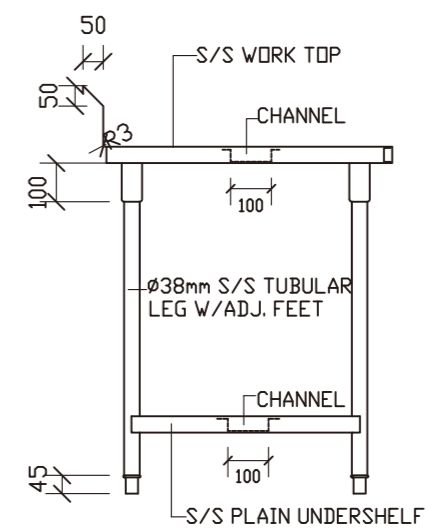

SECTION

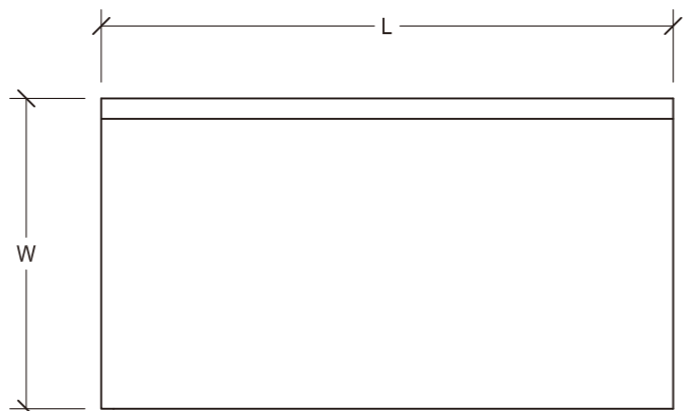

PLAN

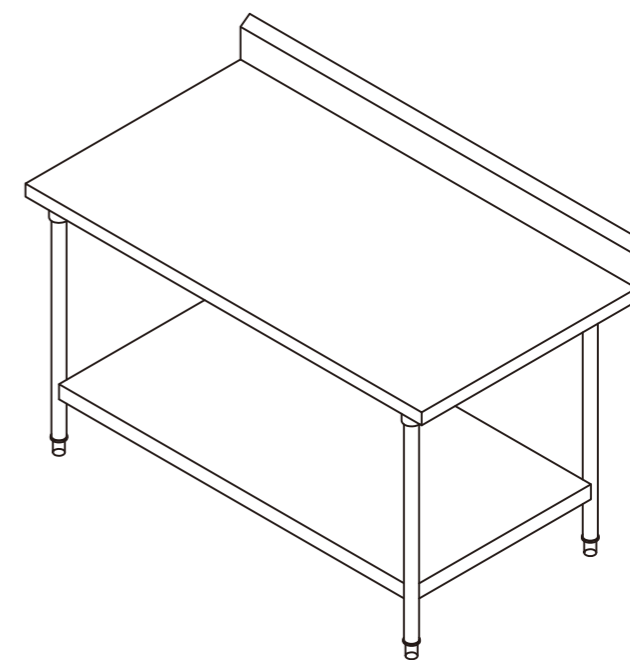

ISOMETRIC VIEW

No:	Item No(款号):	Qty(数量):	No:	Item No(款号):	Qty(数量):

Remark(备注):



SPOT WELDED A THREADED SHAFT TO THE UNDERSIDE OF WORK TOP / SHELF. THEN USE UNITS TO FIX WITH THE REINFORCEMENT / BRACKETS

技术说明:				SKU:			
1.所有产品边缘不能有毛刺, 覆膜面不能刮花;				名称:	建德C40+潜水俱乐部厨房		
2.公差要求标准: 符合GB/T G3280-2015不锈钢冷轧钢板和钢带标准中PT.A的公称宽度要求;				材料:			
3.所有标注尺寸为外尺寸;				编制:		日期:	
4.未注膜面方向朝外。				审核:		日期:	
A						视角:	☉ ☒
版本		批准	日期			版本:	A

STAINLESS STEEL SHOP DRAWING (CUSTOM)

不锈钢件生产要求图

Product Description (产品说明):	Chef Hot Cabinet W/2 Drawers
	打荷台热柜连双抽屉
Model Type (模具型号):	CCHD2 R15

No:	Parts(零部件):	Material Specification(用料标准):
✓ 01	COUNTER TOP 柜台面	16GA. THK. SUS 304 S/S
02	LEG 支腿	∅38mm 16 GA. THK. SUS 304 S/S TUBE
✓ 03	ADJUSTABLE FOOT INSERT 可调节嵌入式底脚	LUI CHUEN KEE (CHN)
✓ 04	REINFORCEMENT 加固件	16 GA. THK. SUS 304 S/S
05	SINK BOWL 洗碗槽	16 GA. THK. SUS 304 S/S
06	SINK WASTE 废料槽	
07	S.S. CROSS RAIL 横梁	∅32mm 16 GA. THK. SUS 304 S/S TUBE
08	WALL MOUNTED BRACKET 壁挂托架	16 GA. THK. SUS 304 S/S
✓ 09	UNDER SHELF 底架	18 GA. THK. SUS 304 S/S
10	MIXING FAUCET 混合龙头	
11	OVER SHELF 顶架	18 GA. THK. SUS 304 S/S
✓ 12	OUTER DOOR PANEL 外板	20 GA. THK. SUS 304 S/S
✓ 13	INNER DOOR PANEL 内板	22 GA. THK. SUS 304 S/S
✓ 14	CABINET BODY 柜身	20 GA. THK. SUS 304 S/S
15	CORNER BUMPER 拐角防护套	COLSON (CHN)
16	SWIVEL CASTOR 旋转角轮	GLOBE (CHN)
17	SOUND DEADEN MATERIAL 隔音材料	3mm THICKNESS
18	WALL FLASHING 防水面	20 GA. THK. SUS 304 S/S
19	CONDENSING UNIT 制冷机组	DANFOSS (CHN)
20	NOZZLE 排气口	∅25mm SUS 304 S/S TUBE

No:	Item No(款号):	Qty(数量):	No:	Item No(款号):	Qty(数量):

Remark(备注):

 M5 SPOT WELDED A THREADED SHAFT TO THE UNDERSIDE OF WORK TOP / SHELF. THEN USE UNITS TO FIX WITH THE REINFORCEMENT / BRACKETS

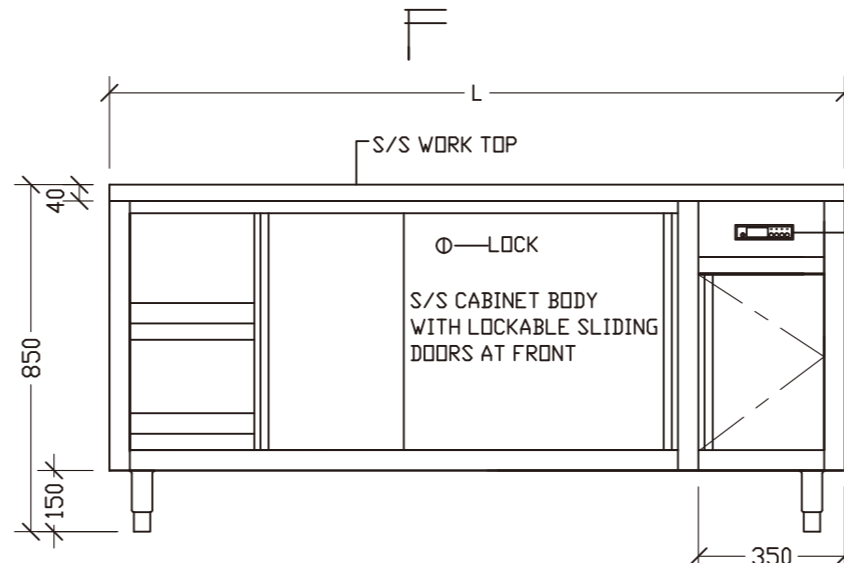

ELEVATION

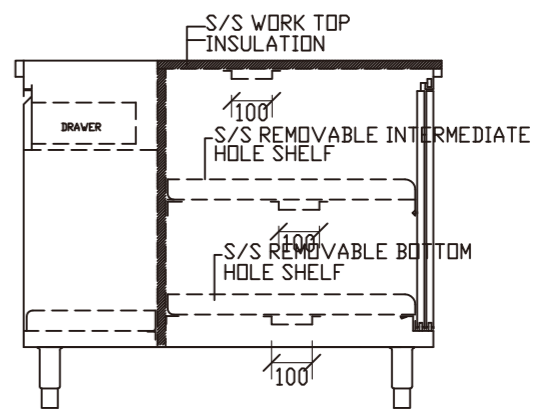

SECTION

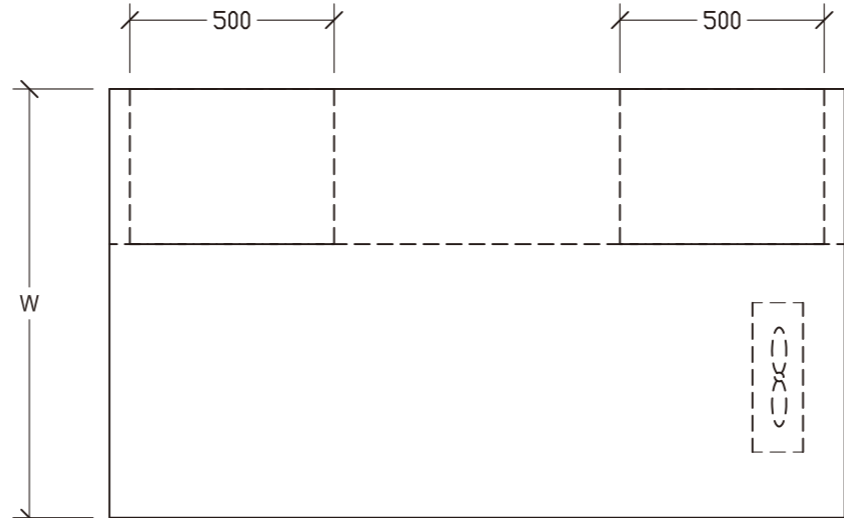

PLAN

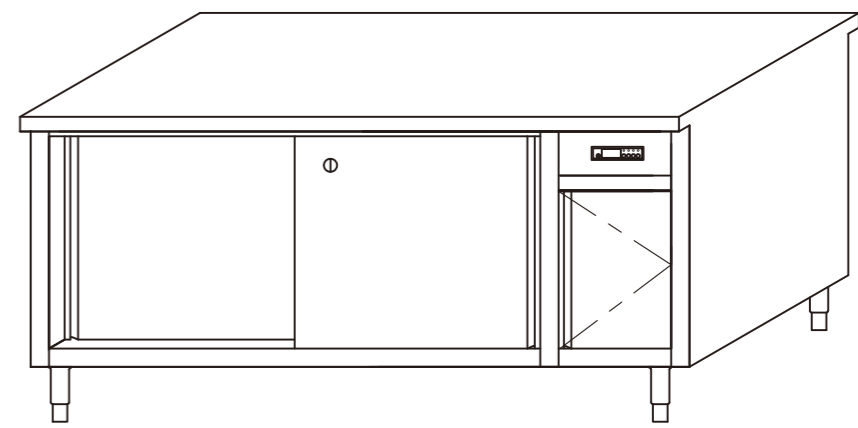

ISOMETRIC VIEW

技术说明:				SKU:			
1.所有产品边缘不能有毛刺, 覆膜面不能刮花;				名称:	建德C40+潜水俱乐部厨房		
2.公差要求标准: 符合GB/T G3280-2015不锈钢冷轧钢板和钢带标准中PT.A的公称宽度要求;				材料:			
3.所有标注尺寸为外尺寸;				编制:		日期:	
4.未注膜面方向朝外。				审核:		日期:	
A						视角:	
版本		批准	日期			版本:	A

STAINLESS STEEL SHOP DRAWING (CUSTOM)

不锈钢件生产要求图

Product Description (产品说明):	Chef Hot Cabinet W/2 Drawers
	打荷台连双抽屉
Model Type (模具型号):	CCHD2 R16

No:	Parts(零部件):	Material Specification(用料标准):
✓ 01	COUNTER TOP 柜台面	16GA. THK. SUS 304 S/S
02	LEG 支腿	∅38mm 16 GA. THK. SUS 304 S/S TUBE
✓ 03	ADJUSTABLE FOOT INSERT 可调节嵌入式底脚	LUI CHUEN KEE (CHN)
✓ 04	REINFORCEMENT 加固件	16 GA. THK. SUS 304 S/S
05	SINK BOWL 洗碗槽	16 GA. THK. SUS 304 S/S
06	SINK WASTE 废料槽	
07	S.S. CROSS RAIL 横梁	∅32mm 16 GA. THK. SUS 304 S/S TUBE
08	WALL MOUNTED BRACKET 壁挂托架	16 GA. THK. SUS 304 S/S
✓ 09	UNDER SHELF 底架	18 GA. THK. SUS 304 S/S
10	MIXING FAUCET 混合龙头	
11	OVER SHELF 顶架	18 GA. THK. SUS 304 S/S
✓ 12	OUTER DOOR PANEL 外板	20 GA. THK. SUS 304 S/S
✓ 13	INNER DOOR PANEL 内板	22 GA. THK. SUS 304 S/S
✓ 14	CABINET BODY 柜身	20 GA. THK. SUS 304 S/S
15	CORNER BUMPER 拐角防护套	COLSON (CHN)
16	SWIVEL CASTOR 旋转角轮	GLOBE (CHN)
17	SOUND DEADEN MATERIAL 隔音材料	3mm THICKNESS
18	WALL FLASHING 防水面	20 GA. THK. SUS 304 S/S
19	CONDENSING UNIT 制冷机组	DANFOSS (CHN)
20	NOZZLE 排气口	∅25mm SUS 304 S/S TUBE

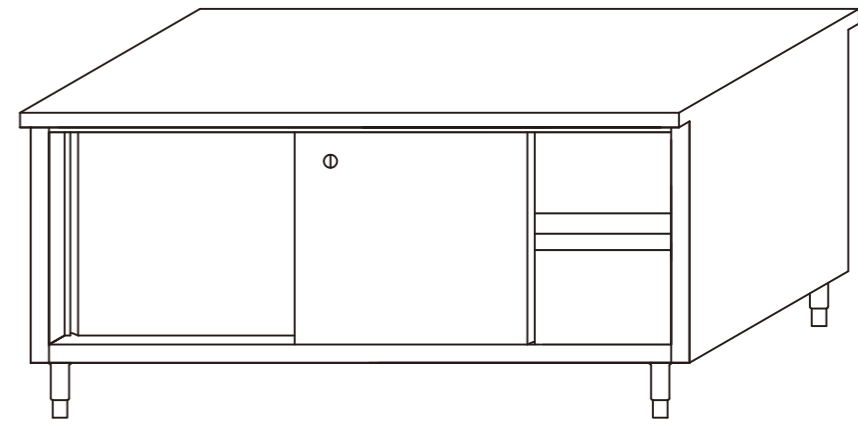
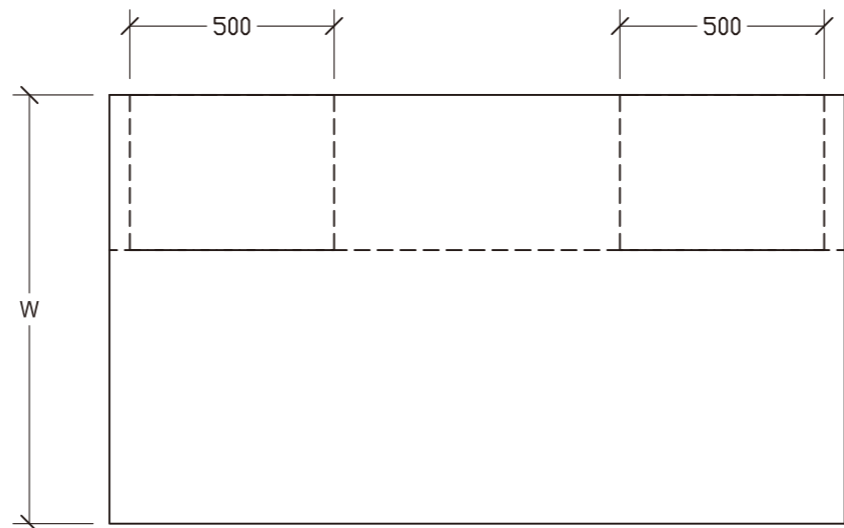
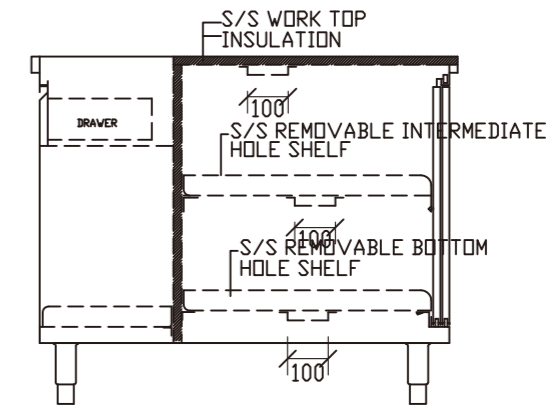
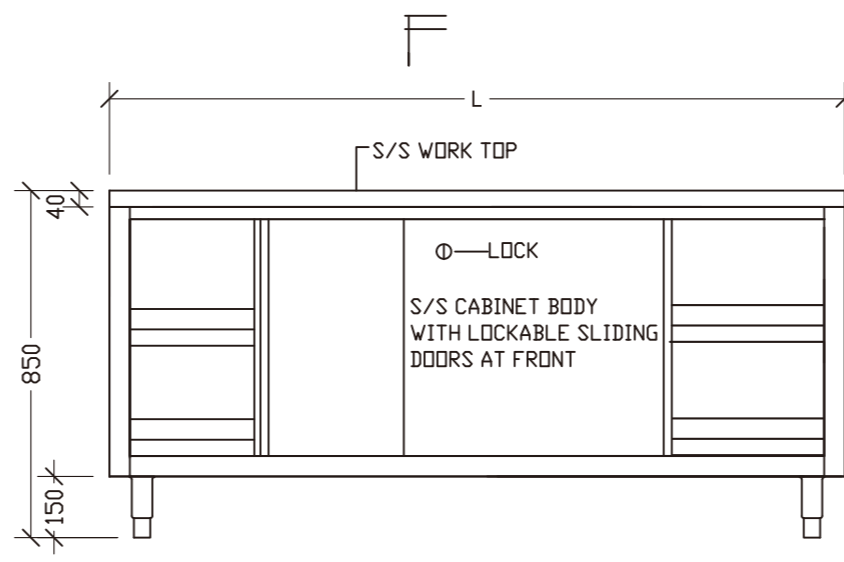

No:	Item No(款号):	Qty(数量):	No:	Item No(款号):	Qty(数量):

Remark(备注):



SPOT WELDED A THREADED SHAFT TO THE UNDERSIDE OF WORK TOP / SHELF. THEN USE UNITS TO FIX WITH THE REINFORCEMENT / BRACKETS

技术说明:
 1.所有产品边缘不能有毛刺, 覆膜面不能刮花;
 2.公差要求标准: 符合GB/T G3280-2015不锈钢冷轧钢板和钢带标准中PT.A的公称宽度要求;
 3.所有标注尺寸为外尺寸;
 4.未注膜面方向朝外。

SKU:		日期:		视角:	☉
名称:	建德C40+潜水俱乐部厨房	日期:		版本:	A
材料:					
编制:					
审核:					

A					
版本			批准	日期	

STAINLESS STEEL SHOP DRAWING (CUSTOM)

不锈钢件生产要求图

Product Description (产品说明):	Work Table W/Twin Sinks
	工作台连双星盆 (中间去水)
Model Type (模具型号):	STSH1 R17

No:	Parts(零部件):	Material Specification(用料标准):
✓ 01	COUNTER TOP 柜台面	16GA. THK. SUS 304 S/S
✓ 02	LEG 支腿	∅38mm 16 GA. THK. SUS 304 S/S TUBE
✓ 03	ADJUSTABLE FOOT INSERT 可调节嵌入式底脚	LUI CHUEN KEE (CHN)
✓ 04	REINFORCEMENT 加固件	16 GA. THK. SUS 304 S/S
✓ 05	SINK BOWL 洗碗槽	16 GA. THK. SUS 304 S/S
06	SINK WASTE 废料槽	
✓ 07	S.S. CROSS RAIL 横梁	∅32mm 16 GA. THK. SUS 304 S/S TUBE
08	WALL MOUNTED BRACKET 壁装托架	16 GA. THK. SUS 304 S/S
09	UNDER SHELF 底架	18 GA. THK. SUS 304 S/S
✓ 10	MIXING FAUCET 混合龙头	
11	OVER SHELF 顶架	18 GA. THK. SUS 304 S/S
12	OUTER DOOR PANEL 外板	20 GA. THK. SUS 304 S/S
13	INNER DOOR PANEL 内板	22 GA. THK. SUS 304 S/S
14	CABINET BODY 柜身	20 GA. THK. SUS 304 S/S
15	CORNER BUMPER 拐角防护套	COLSON (CHN)
16	SWIVEL CASTOR 旋转角轮	GLOBE (CHN)
17	SOUND DEADEN MATERIAL 隔音材料	3mm THICKNESS
18	WALL FLASHING 防水面	20 GA. THK. SUS 304 S/S
19	CONDENSING UNIT 制冷机组	DANFOSS (CHN)
20	NOZZLE 排气口	∅25mm SUS 304 S/S TUBE

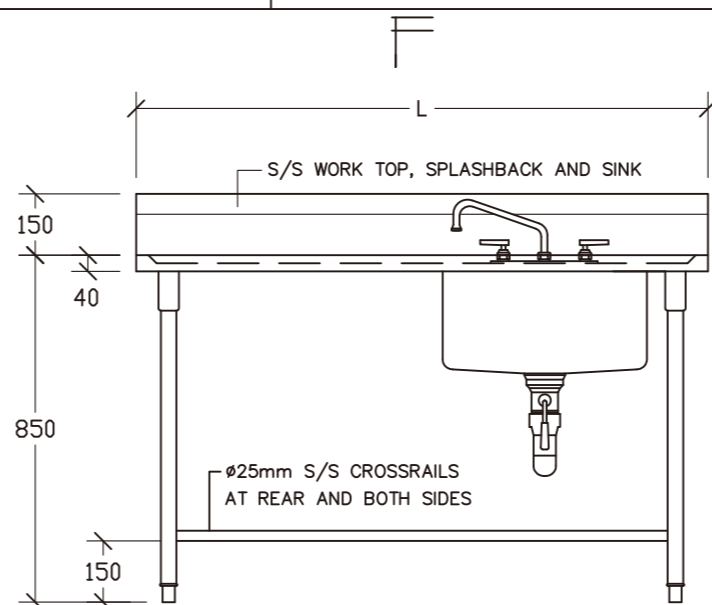

ELEVATION

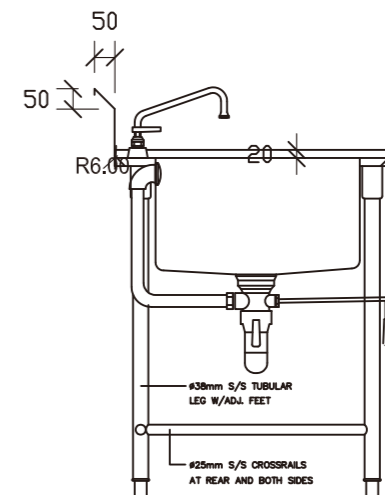

SECTION

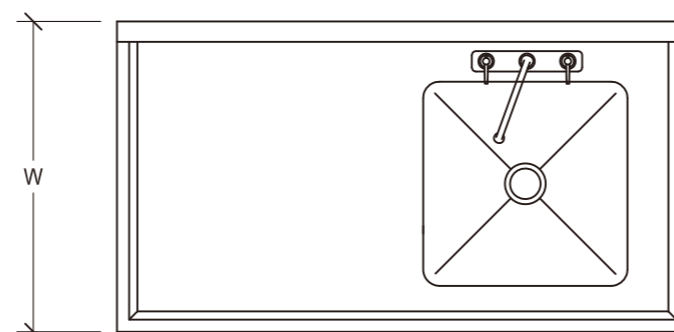

PLAN

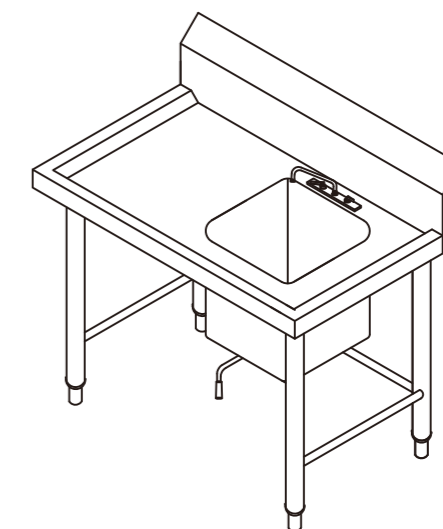

ISOMETRIC VIEW

No:	Item No(款号):	Qty(数量):	No:	Item No(款号):	Qty(数量):

Remark(备注):



SPOT WELDED A THREADED SHAFT TO THE UNDERSIDE OF WORK TOP / SHELF. THEN USE UNITS TO FIX WITH THE REINFORCEMENT / BRACKETS

技术说明:
 1.所有产品边缘不能有毛刺, 覆膜面不能刮花;
 2.公差要求标准: 符合GB/T G3280-2015不锈钢冷轧钢板和钢带标准中PT.A的公称宽度要求;
 3.所有标注尺寸为外尺寸;
 4.未注膜面方向朝外。

SKU:
 名称: 建德C40+潜水俱乐部厨房
 材料:
 编制:
 审核:

日期:
 日期:
 视角:
 版本: A

STAINLESS STEEL SHOP DRAWING (CUSTOM)

不锈钢件生产要求图

Product Description (产品说明):	4-Tier Square Tube Storage Shelving
	四层通架
Model Type (模具型号):	JFG4 R18

No:	Parts(零部件):	Material Specification(用料标准):
01	COUNTER TOP 柜台面	16GA. THK. SUS 304 S/S
✓ 02	LEG 支腿	∅38mm 16 GA. THK. SUS 304 S/S TUBE
✓ 03	ADJUSTABLE FOOT INSERT 可调节嵌入式底脚	LUI CHUEN KEE (CHN)
04	REINFORCEMENT 加固件	16 GA. THK. SUS 304 S/S
05	SINK BOWL 洗碗槽	16 GA. THK. SUS 304 S/S
06	SINK WASTE 废料槽	
✓ 07	S.S. CROSS RAIL 横梁	∅32mm 16 GA. THK. SUS 304 S/S TUBE
08	WALL MOUNTED BRACKET 壁挂托架	16 GA. THK. SUS 304 S/S
09	UNDER SHELF 底架	18 GA. THK. SUS 304 S/S
10	MIXING FAUCET 混合龙头	
11	OVER SHELF 顶架	18 GA. THK. SUS 304 S/S
12	OUTER DOOR PANEL 外板	20 GA. THK. SUS 304 S/S
13	INNER DOOR PANEL 内板	22 GA. THK. SUS 304 S/S
14	CABINET BODY 柜身	20 GA. THK. SUS 304 S/S
15	CORNER BUMPER 拐角防护套	COLSON (CHN)
16	SWIVEL CASTOR 旋转角轮	GLOBE (CHN)
17	SOUND DEADEN MATERIAL 隔音材料	3mm THICKNESS
18	WALL FLASHING 防水面	20 GA. THK. SUS 304 S/S
19	CONDENSING UNIT 制冷机组	DANFOSS (CHN)
20	NOZZLE 排气口	∅25mm SUS 304 S/S TUBE

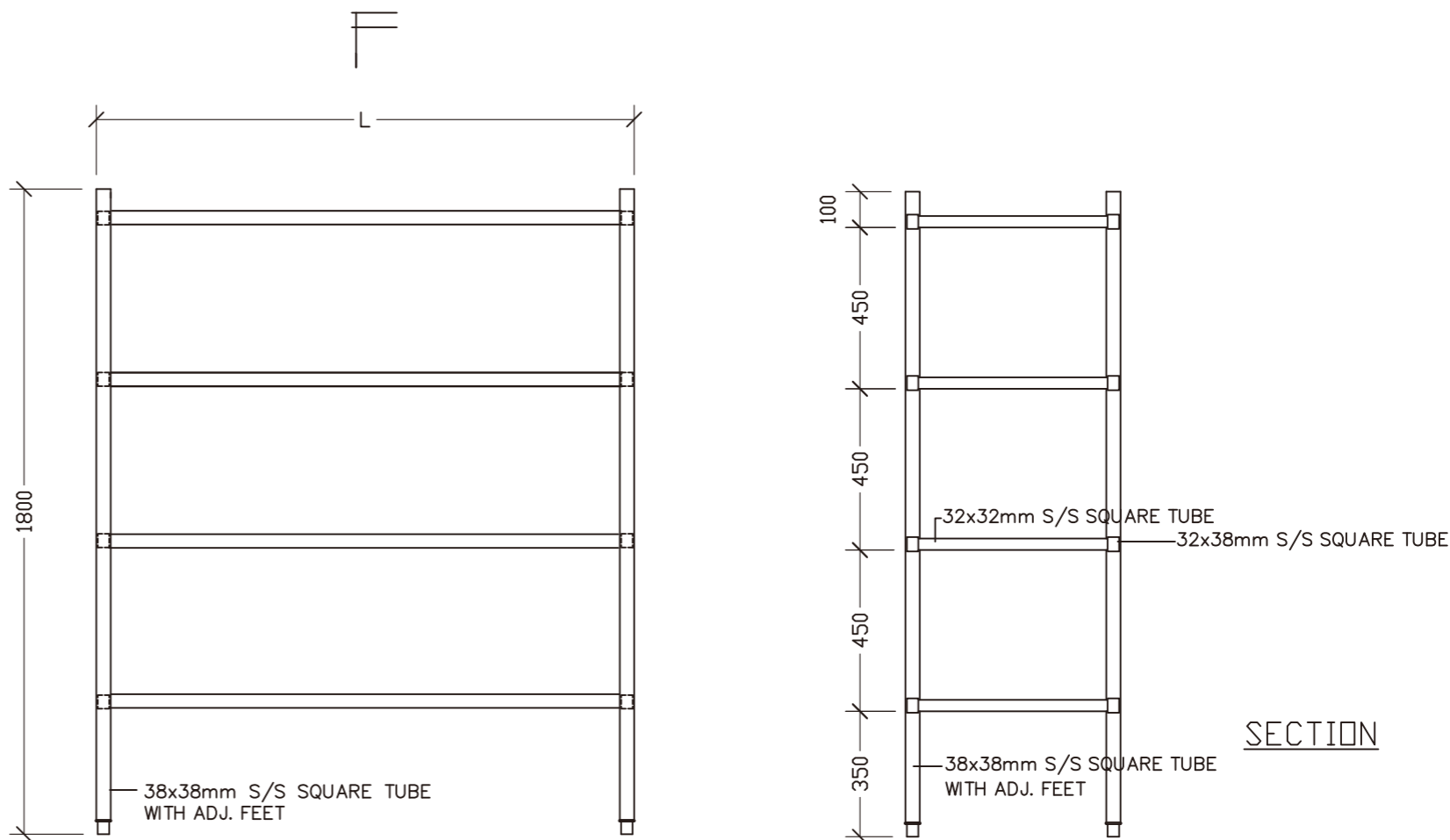

No:	Item No(款号):	Qty(数量):	No:	Item No(款号):	Qty(数量):

Remark(备注):



SPOT WELDED A THREADED SHAFT TO THE UNDERSIDE OF WORK TOP / SHELF. THEN USE UNITS TO FIX WITH THE REINFORCEMENT / BRACKETS

ELEVATION

PLAN

SECTION

技术说明:				SKU:			
1.所有产品边缘不能有毛刺, 覆膜面不能刮花;				名称:	建德C40+潜水俱乐部厨房		
2.公差要求标准: 符合GB/T G3280-2015不锈钢冷轧钢板和钢带标准中PT.A的公称宽度要求;				材料:			
3.所有标注尺寸为外尺寸;				编制:		日期:	
4.未注膜面方向朝外。				审核:		日期:	
A						视角:	☉
版本		批准	日期			版本:	A

STAINLESS STEEL SHOP DRAWING (CUSTOM)

不锈钢件生产要求图

Product Description (产品说明):	4-Tier Square Tube Storage Shelving
	四层通架 S02
Model Type (模具型号):	JFG4

No:	Parts(零部件):	Material Specification(用料标准):
01	COUNTER TOP 柜台面	16GA. THK. SUS 304 S/S
✓ 02	LEG 支腿	∅38mm 16 GA. THK. SUS 304 S/S TUBE
✓ 03	ADJUSTABLE FOOT INSERT 可调节嵌入式底脚	LUI CHUEN KEE (CHN)
04	REINFORCEMENT 加固件	16 GA. THK. SUS 304 S/S
05	SINK BOWL 洗碗槽	16 GA. THK. SUS 304 S/S
06	SINK WASTE 废料槽	
✓ 07	S.S. CROSS RAIL 横梁	∅32mm 16 GA. THK. SUS 304 S/S TUBE
08	WALL MOUNTED BRACKET 壁挂托架	16 GA. THK. SUS 304 S/S
09	UNDER SHELF 底架	18 GA. THK. SUS 304 S/S
10	MIXING FAUCET 混合龙头	
11	OVER SHELF 顶架	18 GA. THK. SUS 304 S/S
12	OUTER DOOR PANEL 外板	20 GA. THK. SUS 304 S/S
13	INNER DOOR PANEL 内板	22 GA. THK. SUS 304 S/S
14	CABINET BODY 柜身	20 GA. THK. SUS 304 S/S
15	CORNER BUMPER 拐角防护套	COLSON (CHN)
16	SWIVEL CASTOR 旋转角轮	GLOBE (CHN)
17	SOUND DEADEN MATERIAL 隔音材料	3mm THICKNESS
18	WALL FLASHING 防水面	20 GA. THK. SUS 304 S/S
19	CONDENSING UNIT 制冷机组	DANFOSS (CHN)
20	NOZZLE 排气口	∅25mm SUS 304 S/S TUBE

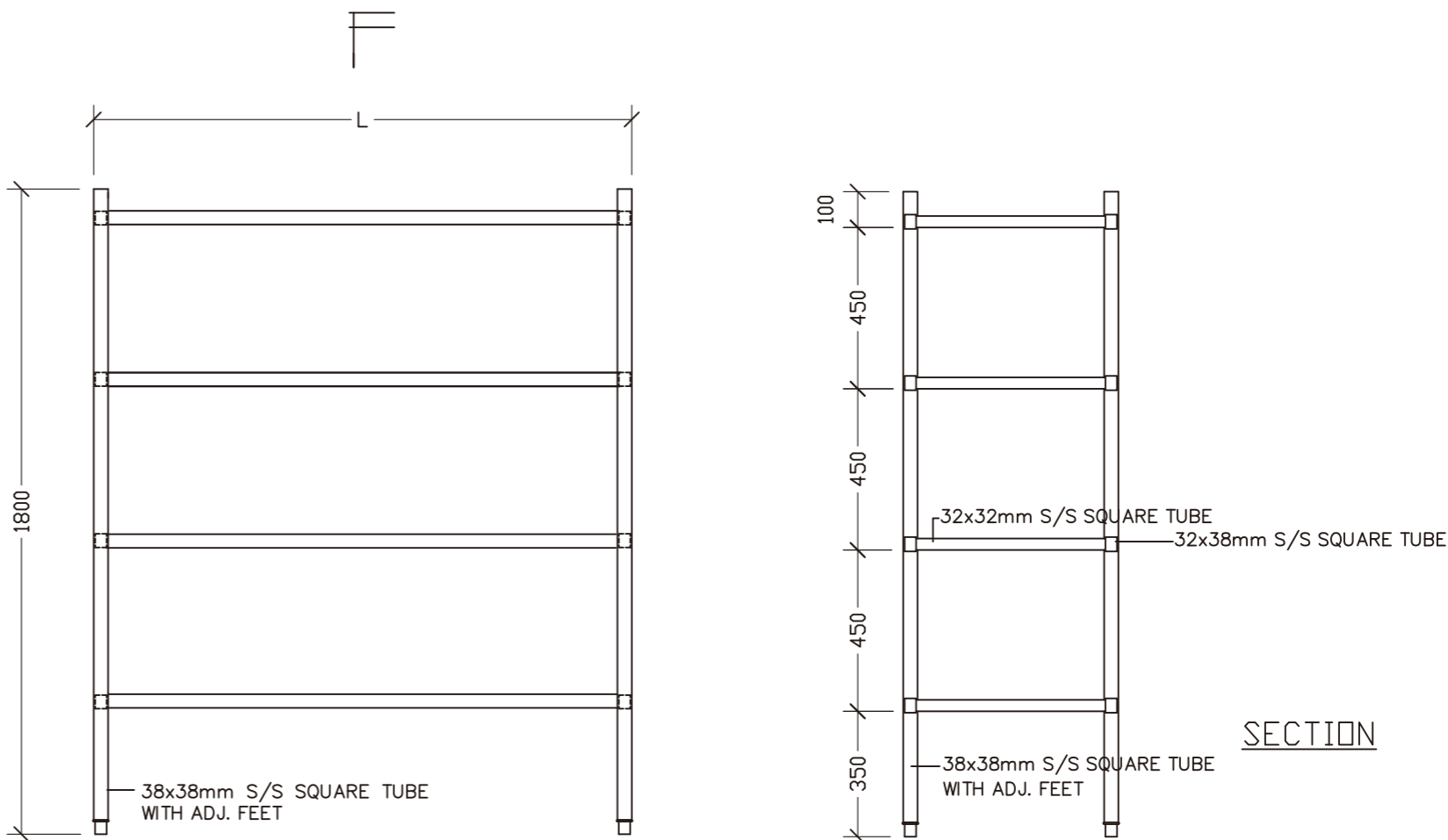

No:	Item No(款号):	Qty(数量):	No:	Item No(款号):	Qty(数量):

Remark(备注):

 M5

SPOT WELDED A THREADED SHAFT TO THE UNDERSIDE OF WORK TOP / SHELF. THEN USE UNITS TO FIX WITH THE REINFORCEMENT / BRACKETS

ELEVATION

PLAN

技术说明:				SKU:			
1.所有产品边缘不能有毛刺, 覆膜面不能刮花;				名称:	建德C40+潜水俱乐部厨房		
2.公差要求标准: 符合GB/T G3280-2015不锈钢冷轧钢板和钢带标准中PT.A的公称宽度要求;				材料:			
3.所有标注尺寸为外尺寸;				编制:		日期:	
4.未注膜面方向朝外。				审核:		日期:	
A						视角:	
版本		批准	日期			版本:	A

STAINLESS STEEL SHOP DRAWING (CUSTOM)

不锈钢件生产要求图

Product Description (产品说明):	Mobile Working Table W/Double Under Shelf
	活动工作台连二下层板
Model Type (模具型号):	TS2-M S04

No:	Parts(零部件):	Material Specification(用料标准):
✓ 01	COUNTER TOP 柜台面	16GA. THK. SUS 304 S/S
✓ 02	LEG 支腿	∅38mm 16 GA. THK. SUS 304 S/S TUBE
03	ADJUSTABLE FOOT INSERT 可调节嵌入式底脚	LUI CHUEN KEE (CHN)
✓ 04	REINFORCEMENT 加固件	16 GA. THK. SUS 304 S/S
05	SINK BOWL 洗碗槽	16 GA. THK. SUS 304 S/S
06	SINK WASTE 废料槽	
07	S.S. CROSS RAIL 横梁	∅32mm 16 GA. THK. SUS 304 S/S TUBE
08	WALL MOUNTED BRACKET 壁挂托架	16 GA. THK. SUS 304 S/S
✓ 09	UNDER SHELF 底架	18 GA. THK. SUS 304 S/S
10	MIXING FAUCET 混合龙头	
11	OVER SHELF 顶架	18 GA. THK. SUS 304 S/S
12	OUTER DOOR PANEL 外板	20 GA. THK. SUS 304 S/S
13	INNER DOOR PANEL 内板	22 GA. THK. SUS 304 S/S
14	CABINET BODY 柜身	20 GA. THK. SUS 304 S/S
15	CORNER BUMPER 拐角防护套	COLSON (CHN)
✓ 16	SWIVEL CASTOR 旋转角轮	GLOBE (CHN)
17	SOUND DEADEN MATERIAL 隔音材料	3mm THICKNESS
18	WALL FLASHING 防水面	20 GA. THK. SUS 304 S/S
19	CONDENSING UNIT 制冷机组	DANFOSS (CHN)
20	NOZZLE 排气口	∅25mm SUS 304 S/S TUBE

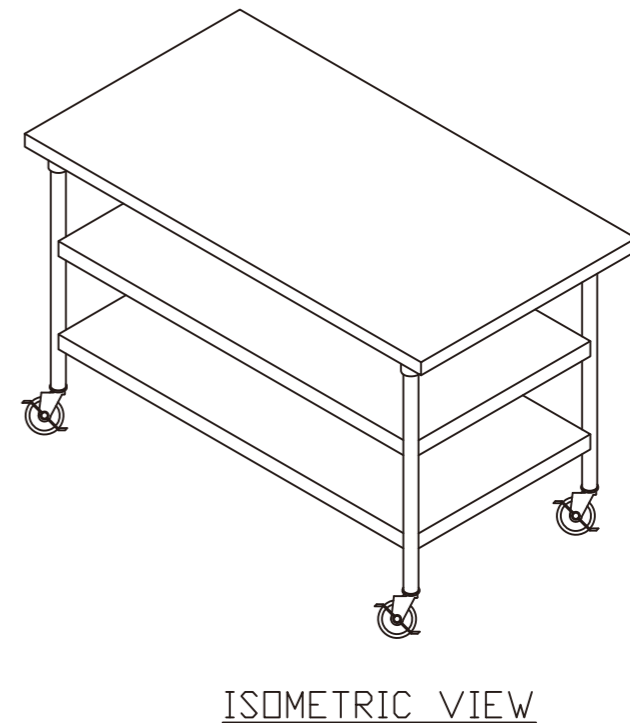
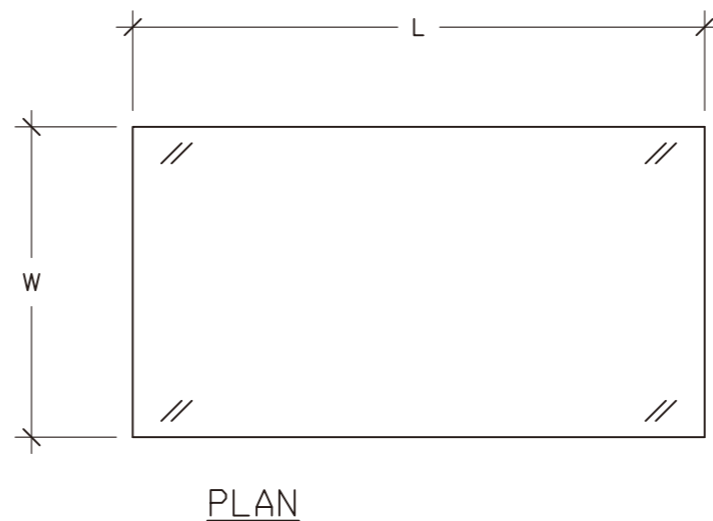
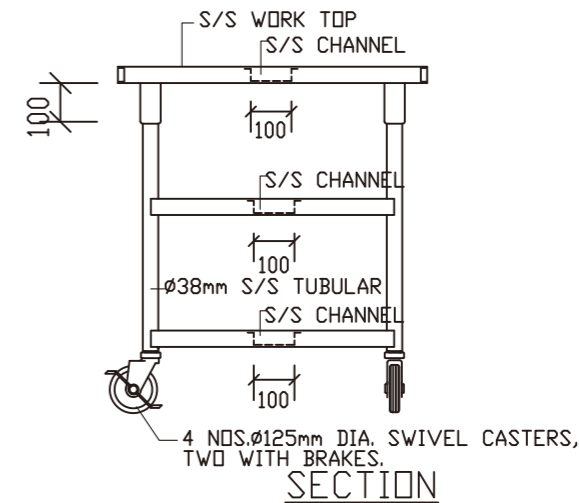
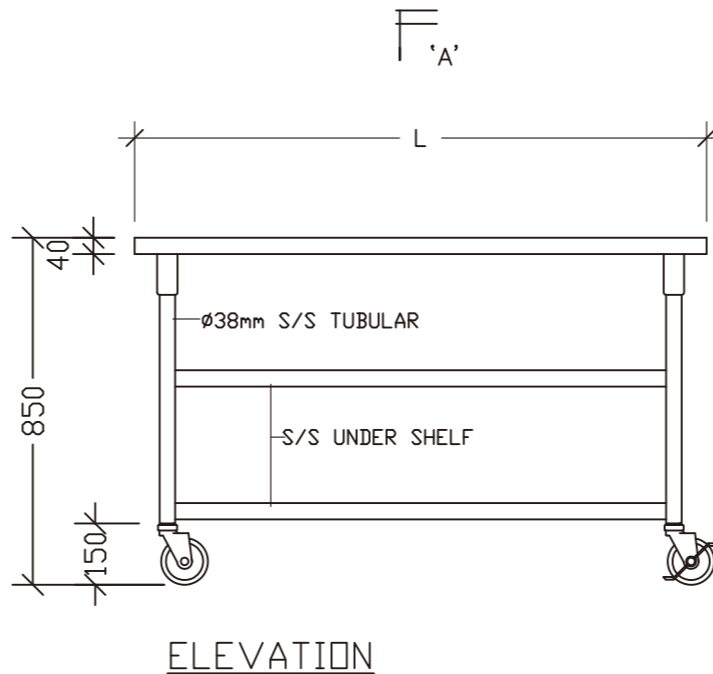

No:	Item No(款号):	Qty(数量):	No:	Item No(款号):	Qty(数量):

Remark(备注):

 SPOT WELDED A THREADED SHAFT TO THE UNDERSIDE OF WORK TOP / SHELF. THEN USE UNITS TO FIX WITH THE REINFORCEMENT / BRACKETS

技术说明:
 1.所有产品边缘不能有毛刺, 覆膜面不能刮花;
 2.公差要求标准: 符合GB/T G3280-2015不锈钢冷轧钢板和钢带标准中PT.A的公称宽度要求;
 3.所有标注尺寸为外尺寸;
 4.未注膜面方向朝外。

SKU:
 名称: 建德C40+潜水俱乐部厨房
 材料:
 编制:
 审核:

日期:
 日期:
 视角: 
 版本: A

A
 版本
 批准
 日期

STAINLESS STEEL SHOP DRAWING (CUSTOM)

不锈钢件生产要求图

Product Description (产品说明):	4-Tier Square Tube Storage Shelving
	四层通架
Model Type (模具型号):	JFG4 S11

No:	Parts(零部件):	Material Specification(用料标准):
01	COUNTER TOP 柜台面	16GA. THK. SUS 304 S/S
✓ 02	LEG 支腿	∅38mm 16 GA. THK. SUS 304 S/S TUBE
✓ 03	ADJUSTABLE FOOT INSERT 可调节嵌入式底脚	LUI CHUEN KEE (CHN)
04	REINFORCEMENT 加固件	16 GA. THK. SUS 304 S/S
05	SINK BOWL 洗碗槽	16 GA. THK. SUS 304 S/S
06	SINK WASTE 废料槽	
✓ 07	S.S. CROSS RAIL 横梁	∅32mm 16 GA. THK. SUS 304 S/S TUBE
08	WALL MOUNTED BRACKET 壁挂托架	16 GA. THK. SUS 304 S/S
09	UNDER SHELF 底架	18 GA. THK. SUS 304 S/S
10	MIXING FAUCET 混合龙头	
11	OVER SHELF 顶架	18 GA. THK. SUS 304 S/S
12	OUTER DOOR PANEL 外板	20 GA. THK. SUS 304 S/S
13	INNER DOOR PANEL 内板	22 GA. THK. SUS 304 S/S
14	CABINET BODY 柜身	20 GA. THK. SUS 304 S/S
15	CORNER BUMPER 拐角防护套	COLSON (CHN)
16	SWIVEL CASTOR 旋转角轮	GLOBE (CHN)
17	SOUND DEADEN MATERIAL 隔音材料	3mm THICKNESS
18	WALL FLASHING 防水面	20 GA. THK. SUS 304 S/S
19	CONDENSING UNIT 制冷机组	DANFOSS (CHN)
20	NOZZLE 排气口	∅25mm SUS 304 S/S TUBE

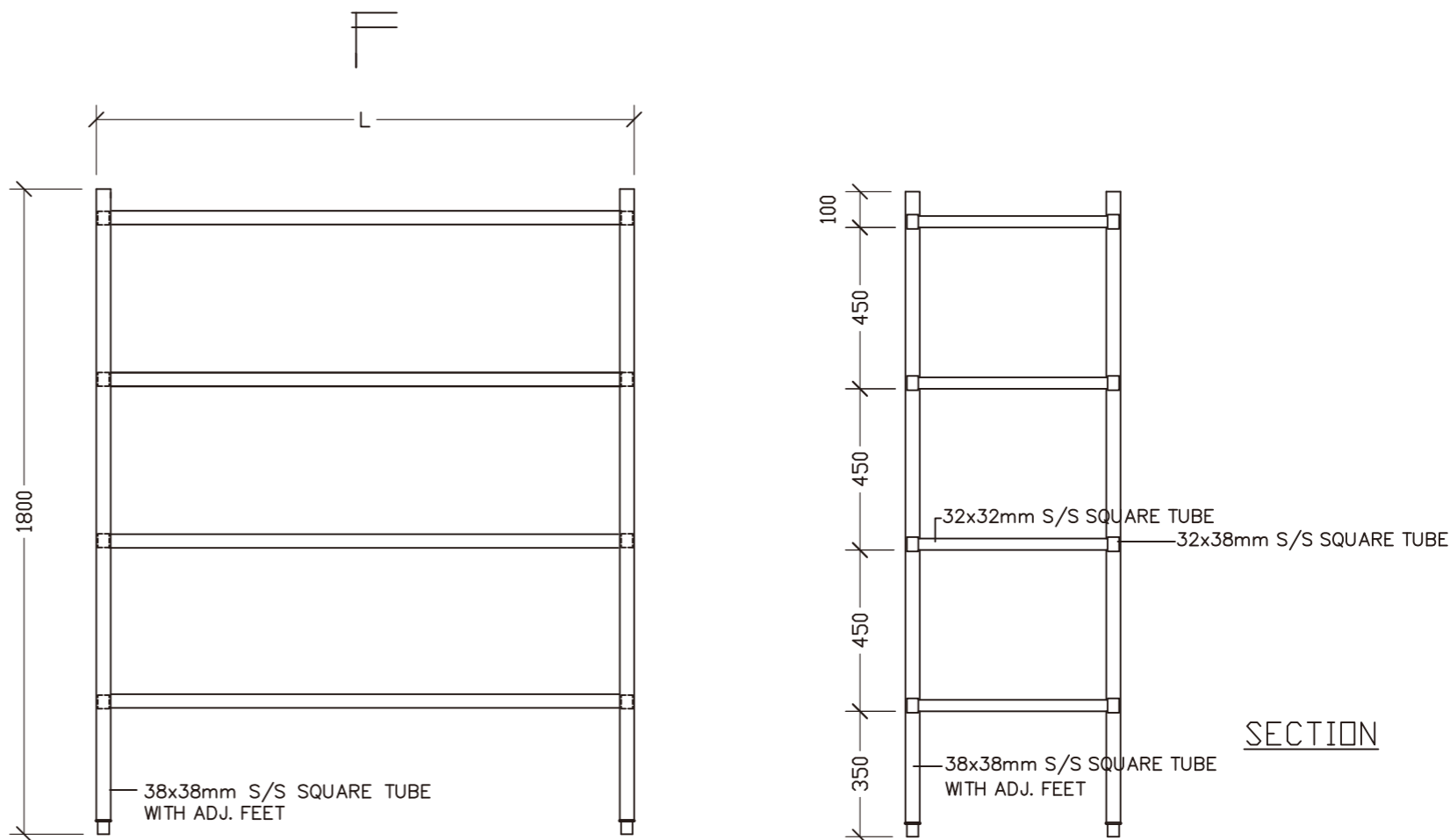

No:	Item No(款号):	Qty(数量):	No:	Item No(款号):	Qty(数量):

Remark(备注):



SPOT WELDED A THREADED SHAFT TO THE UNDERSIDE OF WORK TOP / SHELF. THEN USE UNITS TO FIX WITH THE REINFORCEMENT / BRACKETS

ELEVATION

PLAN

SECTION

技术说明:				SKU:			
1.所有产品边缘不能有毛刺, 覆膜面不能刮花;				名称:	建德C40+潜水俱乐部厨房		
2.公差要求标准: 符合GB/T G3280-2015不锈钢冷轧钢板和钢带标准中PT.A的公称宽度要求;				材料:			
3.所有标注尺寸为外尺寸;				编制:		日期:	
4.未注膜面方向朝外。				审核:		日期:	
A						视角:	☉
版本		批准	日期			版本:	A

STAINLESS STEEL SHOP DRAWING (CUSTOM)

不锈钢件生产要求图

Product Description (产品说明):	Work Table W/Twin Sinks
	工作台连双星盆 (中间去水)
Model Type (模具型号):	STSH1 T01

No:	Parts(零部件):	Material Specification(用料标准):
✓ 01	COUNTER TOP 柜台面	16GA. THK. SUS 304 S/S
✓ 02	LEG 支腿	∅38mm 16 GA. THK. SUS 304 S/S TUBE
✓ 03	ADJUSTABLE FOOT INSERT 可调节嵌入式底脚	LUI CHUEN KEE (CHN)
✓ 04	REINFORCEMENT 加固件	16 GA. THK. SUS 304 S/S
✓ 05	SINK BOWL 洗碗槽	16 GA. THK. SUS 304 S/S
06	SINK WASTE 废料槽	
✓ 07	S.S. CROSS RAIL 横梁	∅32mm 16 GA. THK. SUS 304 S/S TUBE
08	WALL MOUNTED BRACKET 壁装托架	16 GA. THK. SUS 304 S/S
09	UNDER SHELF 底架	18 GA. THK. SUS 304 S/S
✓ 10	MIXING FAUCET 混合龙头	
11	OVER SHELF 顶架	18 GA. THK. SUS 304 S/S
12	OUTER DOOR PANEL 外板	20 GA. THK. SUS 304 S/S
13	INNER DOOR PANEL 内板	22 GA. THK. SUS 304 S/S
14	CABINET BODY 柜身	20 GA. THK. SUS 304 S/S
15	CORNER BUMPER 拐角防护套	COLSON (CHN)
16	SWIVEL CASTOR 旋转角轮	GLOBE (CHN)
17	SOUND DEADEN MATERIAL 隔音材料	3mm THICKNESS
18	WALL FLASHING 防水面	20 GA. THK. SUS 304 S/S
19	CONDENSING UNIT 制冷机组	DANFOSS (CHN)
20	NOZZLE 排气口	∅25mm SUS 304 S/S TUBE

No:	Item No(款号):	Qty(数量):	No:	Item No(款号):	Qty(数量):

Remark(备注):



SPOT WELDED A THREADED SHAFT TO THE UNDERSIDE OF WORK TOP / SHELF. THEN USE UNITS TO FIX WITH THE REINFORCEMENT / BRACKETS

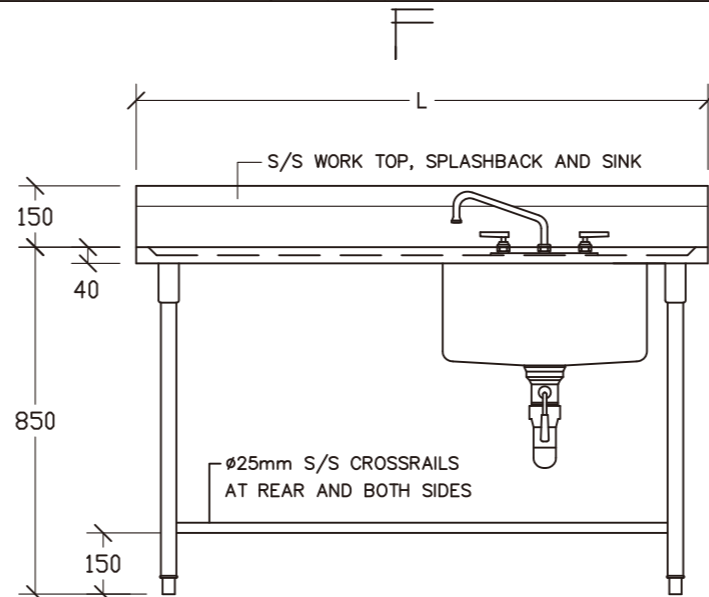

ELEVATION

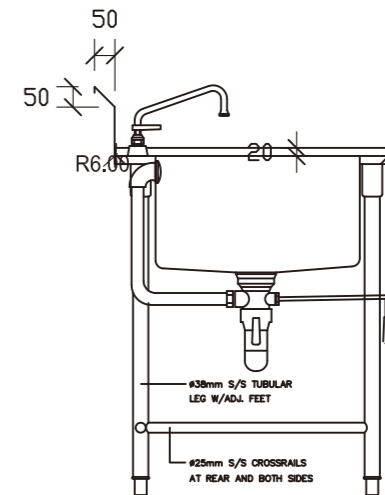

SECTION

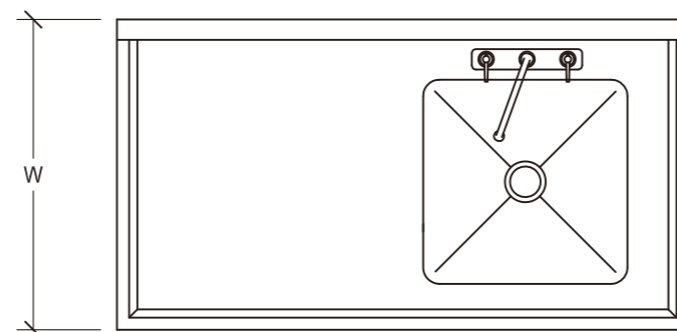

PLAN

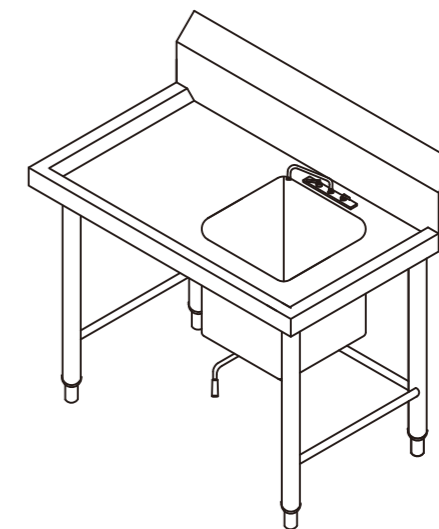

ISOMETRIC VIEW

技术说明:				SKU:			
1.所有产品边缘不能有毛刺, 覆膜面不能刮花;				名称:	建德C40+潜水俱乐部厨房		
2.公差要求标准: 符合GB/T G3280-2015不锈钢冷轧钢板和钢带标准中PT.A的公称宽度要求;				材料:			
3.所有标注尺寸为外尺寸;				编制:		日期:	
4.未注膜面方向朝外。				审核:		日期:	
A						视角:	☉ ☒
版本		批准	日期			版本:	A

STAINLESS STEEL SHOP DRAWING (CUSTOM)

不锈钢件生产要求图

Product Description (产品说明):	Single Wall Mounted Shelving
	单层挂墙层架
Model Type (模具型号):	JBW1 T03

No:	Parts(零部件):	Material Specification(用料标准):
01	COUNTER TOP 柜台面	16GA. THK. SUS 304 S/S
02	LEG 支腿	Ø38mm 16 GA. THK. SUS 304 S/S TUBE
03	ADJUSTABLE FOOT INSERT 可调节嵌入式底脚	LUI CHUEN KEE (CHN)
✓ 04	REINFORCEMENT 加固件	16 GA. THK. SUS 304 S/S
05	SINK BOWL 洗碗槽	16 GA. THK. SUS 304 S/S
06	SINK WASTE 废料槽	
07	S.S. CROSS RAIL 横梁	Ø32mm 16 GA. THK. SUS 304 S/S TUBE
✓ 08	WALL MOUNTED BRACKET 壁挂托架	16 GA. THK. SUS 304 S/S
09	UNDER SHELF 底架	18 GA. THK. SUS 304 S/S
10	MIXING FAUCET 混合龙头	
✓ 11	OVER SHELF 顶架	18 GA. THK. SUS 304 S/S
12	OUTER DOOR PANEL 外板	20 GA. THK. SUS 304 S/S
13	INNER DOOR PANEL 内板	22 GA. THK. SUS 304 S/S
14	CABINET BODY 柜身	20 GA. THK. SUS 304 S/S
15	CORNER BUMPER 拐角防护套	COLSON (CHN)
16	SWIVEL CASTOR 旋转角轮	GLOBE (CHN)
17	SOUND DEADEN MATERIAL 隔音材料	3mm THICKNESS
18	WALL FLASHING 防水面	20 GA. THK. SUS 304 S/S
19	CONDENSING UNIT 制冷机组	DANFOSS (CHN)
20	NOZZLE 排气口	Ø25mm SUS 304 S/S TUBE

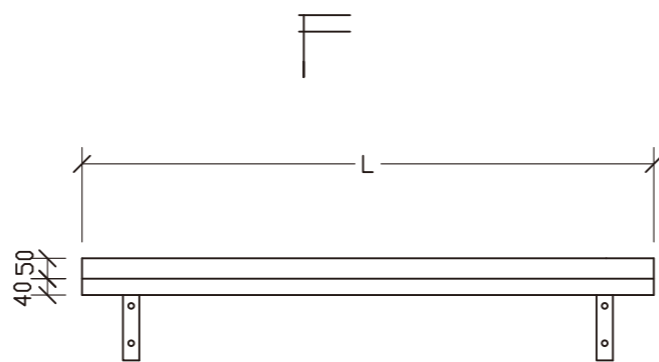

ELEVATION

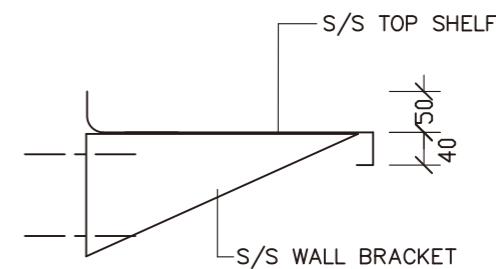

SECTION

No:	Item No(款号):	Qty(数量):	No:	Item No(款号):	Qty(数量):

Remark(备注):



SPOT WELDED A THREADED SHAFT TO THE UNDERSIDE OF WORK TOP / SHELF. THEN USE UNITS TO FIX WITH THE REINFORCEMENT / BRACKETS

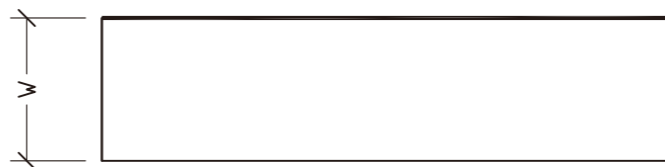

PLAN

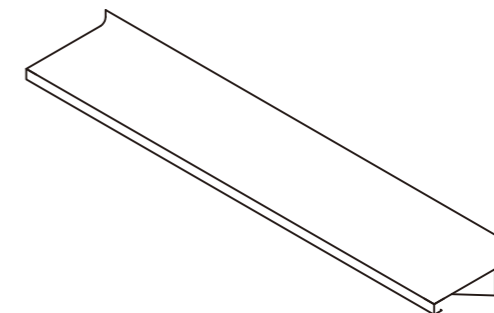

ISOMETRIC VIEW

技术说明:				SKU:			
1.所有产品边缘不能有毛刺, 覆膜面不能刮花;				名称:	建德C40+潜水俱乐部厨房		
2.公差要求标准: 符合GB/T G3280-2015不锈钢冷轧钢板和钢带标准中PT.A的公称宽度要求;				材料:			
3.所有标注尺寸为外尺寸;				编制:		日期:	
4.未注膜面方向朝外。				审核:		日期:	
A						视角:	☉
版本		批准	日期			版本:	A

STAINLESS STEEL SHOP DRAWING (CUSTOM)

不锈钢件生产要求图

Product Description (产品说明):	Uright Storage Cabinet
	高身储物柜
Model Type (模具型号):	CUS T04

No:	Parts(零部件):	Material Specification(用料标准):
✓ 01	COUNTER TOP 柜台面	16GA. THK. SUS 304 S/S
02	LEG 支腿	∅38mm 16 GA. THK. SUS 304 S/S TUBE
✓ 03	ADJUSTABLE FOOT INSERT 可调节嵌入式底脚	LUI CHUEN KEE (CHN)
✓ 04	REINFORCEMENT 加固件	16 GA. THK. SUS 304 S/S
05	SINK BOWL 洗碗槽	16 GA. THK. SUS 304 S/S
06	SINK WASTE 废料槽	
07	S.S. CROSS RAIL 横梁	∅32mm 16 GA. THK. SUS 304 S/S TUBE
08	WALL MOUNTED BRACKET 壁装托架	16 GA. THK. SUS 304 S/S
✓ 09	UNDER SHELF 底架	18 GA. THK. SUS 304 S/S
10	MIXING FAUCET 混合龙头	
11	OVER SHELF 顶架	18 GA. THK. SUS 304 S/S
✓ 12	OUTER DOOR PANEL 外板	20 GA. THK. SUS 304 S/S
✓ 13	INNER DOOR PANEL 内板	22 GA. THK. SUS 304 S/S
✓ 14	CABINET BODY 柜身	20 GA. THK. SUS 304 S/S
15	CORNER BUMPER 拐角防护套	COLSON (CHN)
16	SWIVEL CASTOR 旋转角轮	GLOBE (CHN)
17	SOUND DEADEN MATERIAL 隔音材料	3mm THICKNESS
18	WALL FLASHING 防水面	20 GA. THK. SUS 304 S/S
19	CONDENSING UNIT 制冷机组	DANFOSS (CHN)
20	NOZZLE 排气口	∅25mm SUS 304 S/S TUBE

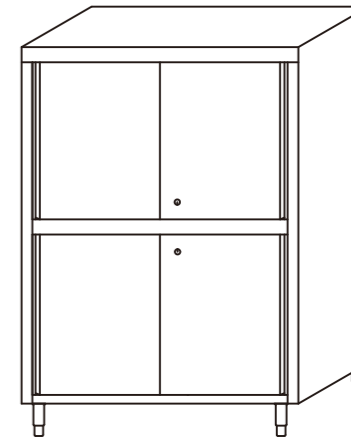
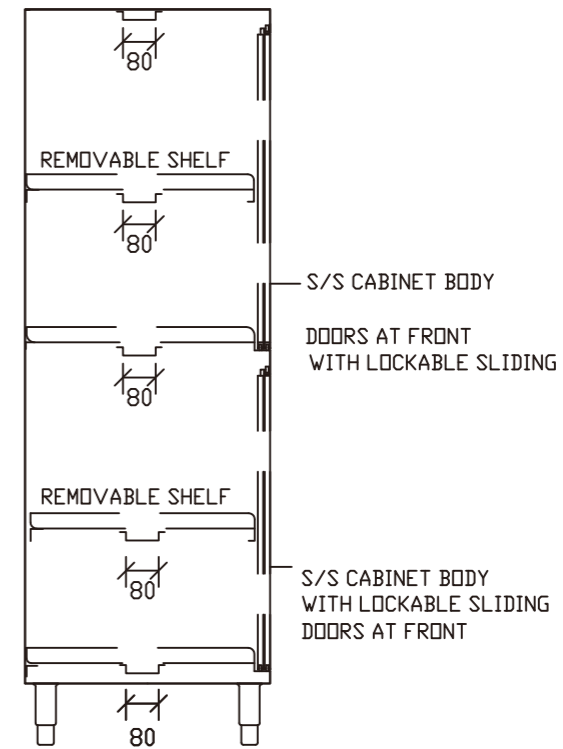
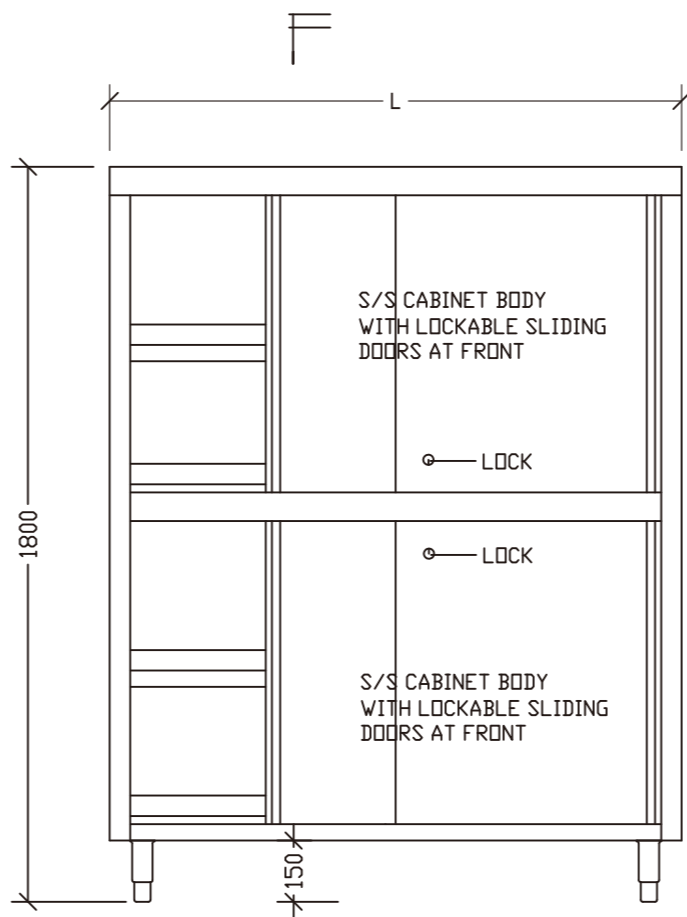

No:	Item No(款号):	Qty(数量):	No:	Item No(款号):	Qty(数量):

Remark(备注):

M5 SPOT WELDED A THREADED SHAFT TO THE UNDERSIDE OF WORK TOP / SHELF. THEN USE UNITS TO FIX WITH THE REINFORCEMENT / BRACKETS

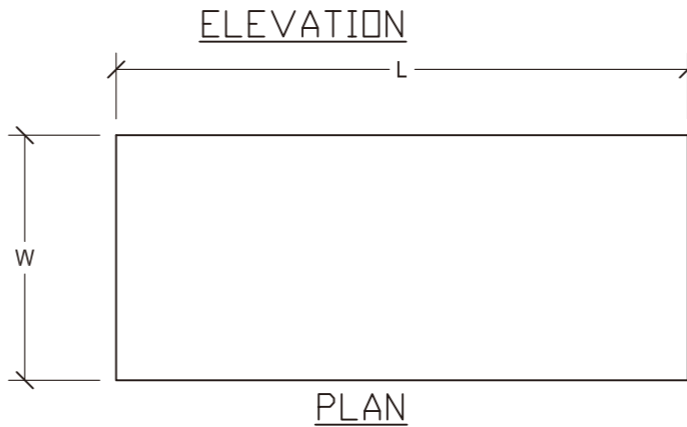

SECTION

ISOMETRIC VIEW

技术说明:				SKU:			
1.所有产品边缘不能有毛刺, 覆膜面不能刮花;				名称:	建德C40+潜水俱乐部厨房		
2.公差要求标准: 符合GB/T G3280-2015不锈钢冷轧钢板和钢带标准中PT.A的公称宽度要求;				材料:			
3.所有标注尺寸为外尺寸;				编制:		日期:	
4.未注膜面方向朝外。				审核:		日期:	
A						视角:	
版本		批准	日期			版本:	A

STAINLESS STEEL SHOP DRAWING (CUSTOM)

不锈钢件生产要求图

Product Description (产品说明):	Bain Marie Cabinet
	热汤池柜
Model Type (模具型号):	CBM T06

No:	Parts(零部件):	Material Specfication(用料标准):
✓ 01	COUNTER TOP 柜台面	16GA. THK. SUS 304 S/S
02	LEG 支腿	∅38mm 16 GA. THK. SUS 304 S/S TUBE
✓ 03	ADJUSTABLE FOOT INSERT 可调节嵌入式底脚	LUI CHUEN KEE (CHN)
✓ 04	REINFORCEMENT 加固件	16 GA. THK. SUS 304 S/S
✓ 05	SINK BOWL 洗碗槽	16 GA. THK. SUS 304 S/S
06	SINK WASTE 废料槽	
07	S.S. CROSS RAIL 横梁	∅32mm 16 GA. THK. SUS 304 S/S TUBE
08	WALL MOUNTED BRACKET 壁装托架	16 GA. THK. SUS 304 S/S
✓ 09	UNDER SHELF 底架	18 GA. THK. SUS 304 S/S
10	MIXING FAUCET 混合龙头	
11	OVER SHELF 顶架	18 GA. THK. SUS 304 S/S
✓ 12	OUTER DOOR PANEL 外板	20 GA. THK. SUS 304 S/S
✓ 13	INNER DOOR PANEL 内板	22 GA. THK. SUS 304 S/S
✓ 14	CABINET BODY 柜身	20 GA. THK. SUS 304 S/S
15	CORNER BUMPER 拐角防护套	COLSON (CHN)
16	SWIVEL CASTOR 旋转角轮	GLOBE (CHN)
17	SOUND DEADEN MATERIAL 隔音材料	3mm THICKNESS
18	WALL FLASHING 防水面	20 GA. THK. SUS 304 S/S
19	CONDENSING UNIT 制冷机组	DANFOSS (CHN)
20	NOZZLE 排气口	∅25mm SUS 304 S/S TUBE

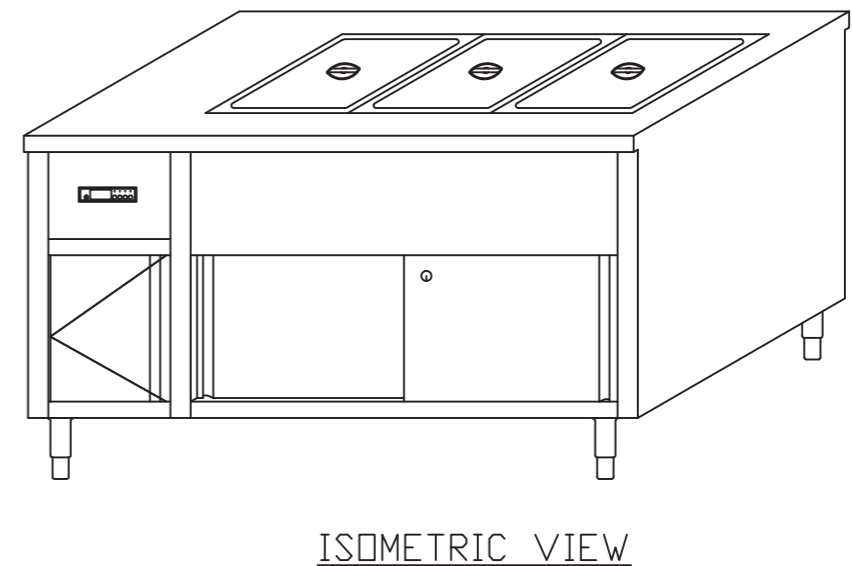
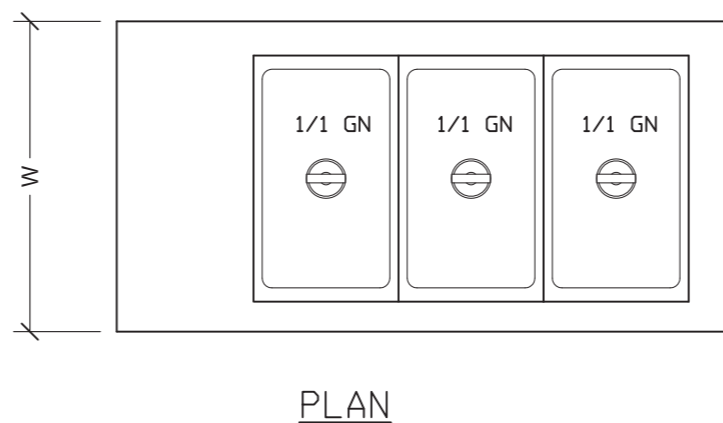
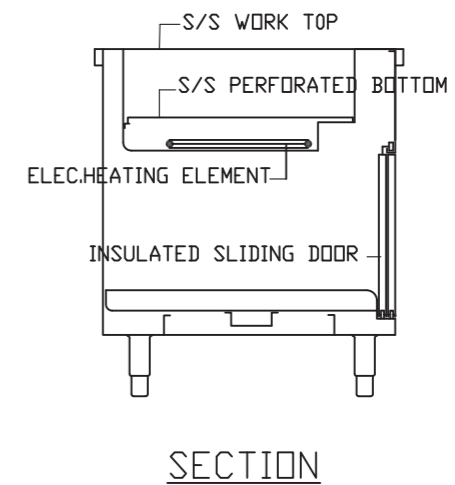
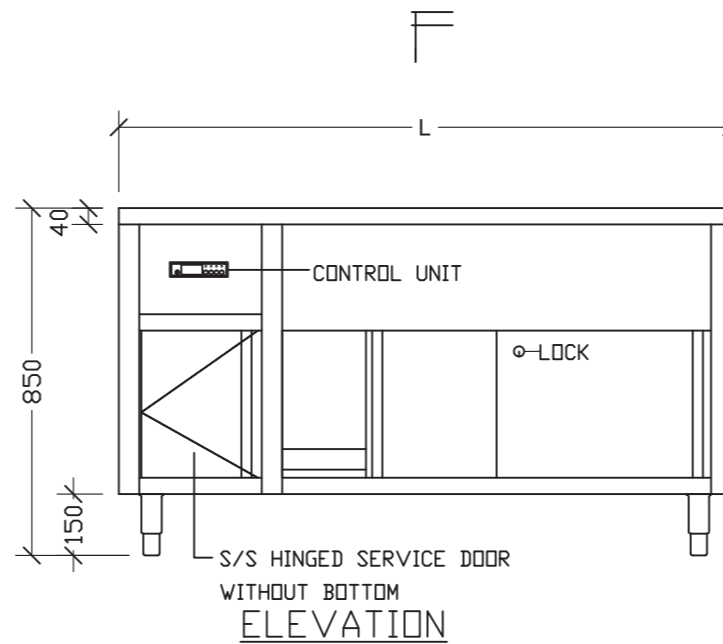

No:	Item No(款号):	Qty(数量):	No:	Item No(款号):	Qty(数量):

Remark(备注):



SPOT WELDED A THREADED SHAFT TO THE UNDERSIDE OF WORK TOP / SHELF. THEN USE UNITS TO FIX WITH THE REINFORCEMENT / BRACKETS

				技术说明:	SKU:					
				1.所有产品边缘不能有毛刺, 覆膜面不能刮花;	名称:	建德C40+潜水俱乐部厨房				
				2.公差要求标准: 符合GB/T G3280-2015不锈钢冷轧钢板和钢带标准中PT.A的公称宽度要求;	材料:					
				3.所有标注尺寸为外尺寸;	编制:					
				4.未注膜面方向朝外。	审核:					
A						日期:		视角:	☉	
版本			批准	日期		日期:		版本:	A	

STAINLESS STEEL SHOP DRAWING (CUSTOM)

不锈钢件生产要求图

Product Description (产品说明):	Work Cabinet
	工作掩门柜
Model Type (模具型号):	CBH T08

No:	Parts(零部件):	Material Specification(用料标准):
✓ 01	COUNTER TOP 柜台面	16GA. THK. SUS 304 S/S
02	LEG 支腿	Ø38mm 16 GA. THK. SUS 304 S/S TUBE
✓ 03	ADJUSTABLE FOOT INSERT 可调节嵌入式底脚	LUI CHUEN KEE (CHN)
✓ 04	REINFORCEMENT 加固件	16 GA. THK. SUS 304 S/S
05	SINK BOWL 洗碗槽	16 GA. THK. SUS 304 S/S
06	SINK WASTE 废料槽	
07	S.S. CROSS RAIL 横梁	Ø32mm 16 GA. THK. SUS 304 S/S TUBE
08	WALL MOUNTED BRACKET 壁装托架	16 GA. THK. SUS 304 S/S
✓ 09	UNDER SHELF 底架	18 GA. THK. SUS 304 S/S
10	MIXING FAUCET 混合龙头	
11	OVER SHELF 顶架	18 GA. THK. SUS 304 S/S
✓ 12	OUTER DOOR PANEL 外板	20 GA. THK. SUS 304 S/S
✓ 13	INNER DOOR PANEL 内板	22 GA. THK. SUS 304 S/S
✓ 14	CABINET BODY 柜身	20 GA. THK. SUS 304 S/S
15	CORNER BUMPER 拐角防护套	COLSON (CHN)
16	SWIVEL CASTOR 旋转角轮	GLOBE (CHN)
17	SOUND DEADEN MATERIAL 隔音材料	3mm THICKNESS
18	WALL FLASHING 防水面	20 GA. THK. SUS 304 S/S
19	CONDENSING UNIT 制冷机组	DANFOSS (CHN)
20	NOZZLE 排气口	Ø25mm SUS 304 S/S TUBE

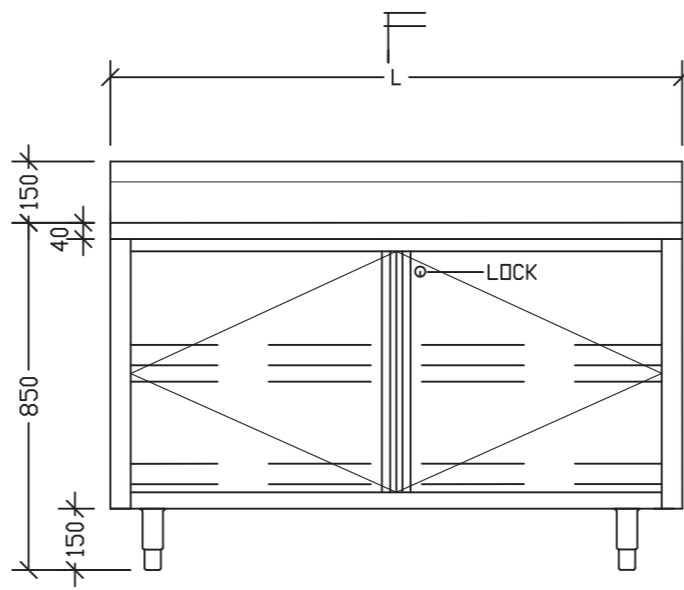

ELEVATION

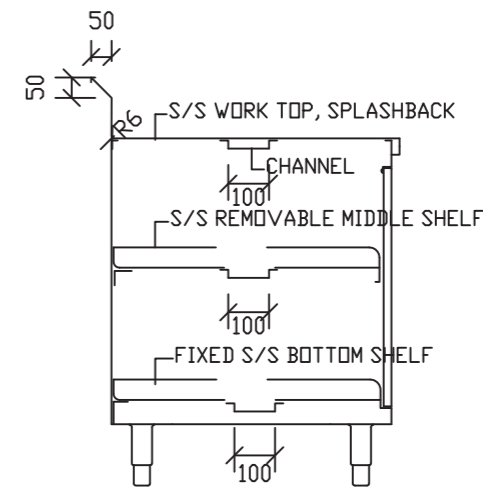

SECTION

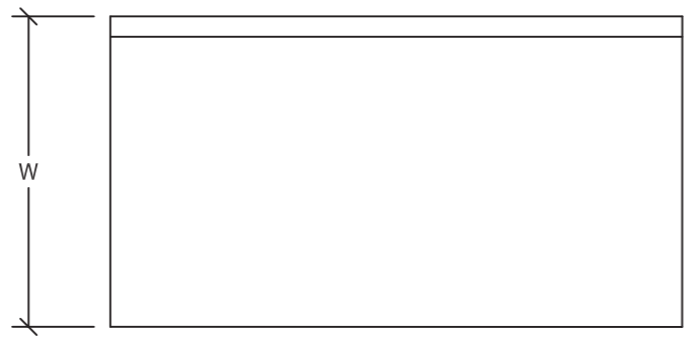

PLAN

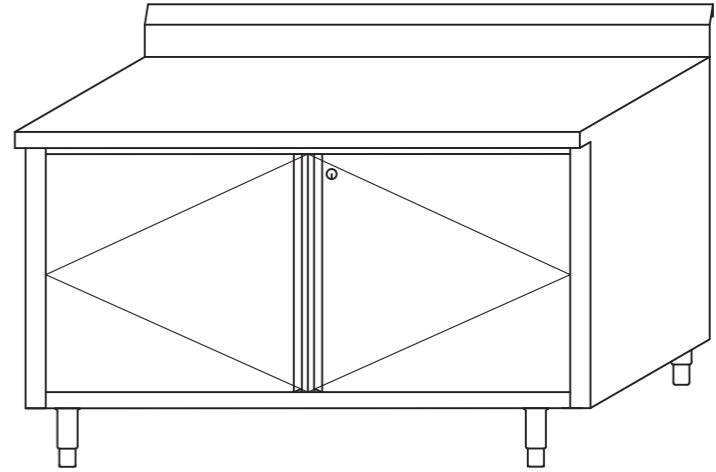

ISOMETRIC VIEW

No:	Item No(款号):	Qty(数量):	No:	Item No(款号):	Qty(数量):

Remark(备注):

M5	SPOT WELDED A THREADED SHAFT TO THE UNDERSIDE OF WORK TOP / SHELF. THEN USE UNITS TO FIX WITH THE REINFORCEMENT / BRACKETS
----	--

技术说明:				SKU:			
1.所有产品边缘不能有毛刺, 覆膜面不能刮花;				名称:	建德C40+潜水俱乐部厨房		
2.公差要求标准: 符合GB/T G3280-2015不锈钢冷轧钢板和钢带标准中PT.A的公称宽度要求;				材料:			
3.所有标注尺寸为外尺寸;				编制:		日期:	
4.未注膜面方向朝外。				审核:		日期:	
A						视角:	
版本		批准	日期			版本:	A

STAINLESS STEEL SHOP DRAWING (CUSTOM)

不锈钢件生产要求图

Product Description (产品说明):	Hand Wash Sink
	挂墙洗手星盆
Model Type (模具型号):	SHSC1-W U01

No:	Parts(零部件):	Material Specfication(用料标准):
✓ 01	COUNTER TOP 柜台面	16GA. THK. SUS 304 S/S
02	LEG 支腿	∅38mm 16 GA. THK. SUS 304 S/S TUBE
03	ADJUSTABLE FOOT INSERT 可调节嵌入式底脚	LUI CHUEN KEE (CHN)
✓ 04	REINFORCEMENT 加固件	16 GA. THK. SUS 304 S/S
✓ 05	SINK BOWL 洗碗槽	16 GA. THK. SUS 304 S/S
06	SINK WASTE 废料槽	
07	S.S. CROSS RAIL 横梁	∅32mm 16 GA. THK. SUS 304 S/S TUBE
✓ 08	WALL MOUNTED BRACKET 壁装托架	16 GA. THK. SUS 304 S/S
09	UNDER SHELF 底架	18 GA. THK. SUS 304 S/S
✓ 10	MIXING FAUCET 混合龙头	
11	OVER SHELF 顶架	18 GA. THK. SUS 304 S/S
12	OUTER DOOR PANEL 外板	20 GA. THK. SUS 304 S/S
13	INNER DOOR PANEL 内板	22 GA. THK. SUS 304 S/S
14	CABINET BODY 柜身	20 GA. THK. SUS 304 S/S
15	CORNER BUMPER 拐角防护套	COLSON (CHN)
16	SWIVEL CASTOR 旋转角轮	GLOBE (CHN)
17	SOUND DEADEN MATERIAL 隔音材料	3mm THICKNESS
18	WALL FLASHING 防水面	20 GA. THK. SUS 304 S/S
19	CONDENSING UNIT 制冷机组	DANFOSS (CHN)
20	NOZZLE 排气口	∅25mm SUS 304 S/S TUBE

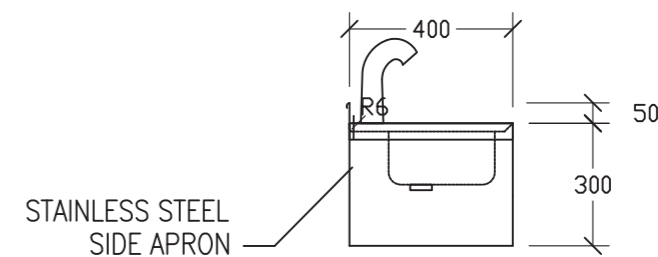
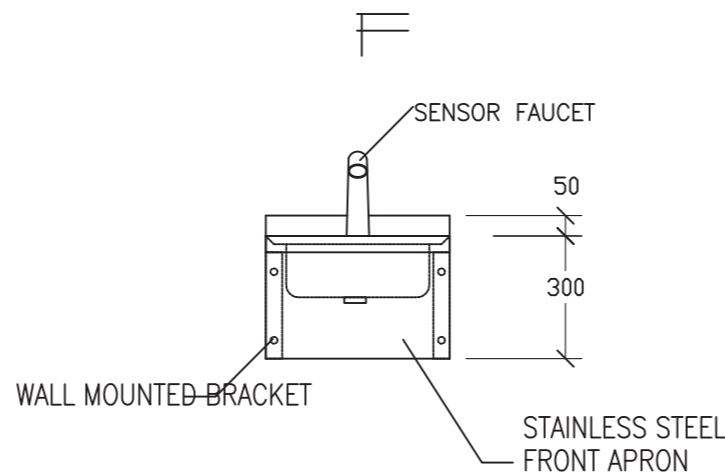

ELEVATION

SECTION

No:	Item No(款号):	Qty(数量):	No:	Item No(款号):	Qty(数量):

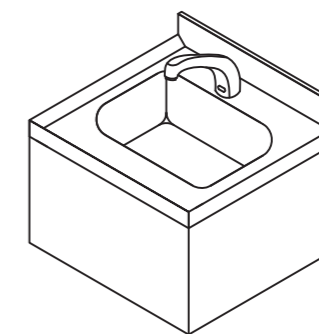
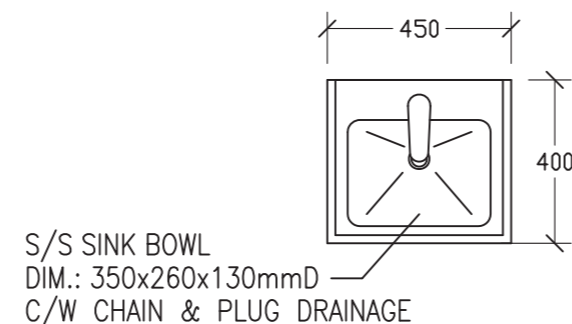

Remark(备注):



SPOT WELDED A THREADED SHAFT TO THE UNDERSIDE OF WORK TOP / SHELF. THEN USE UNITS TO FIX WITH THE REINFORCEMENT / BRACKETS

技术说明:				SKU:			
1.所有产品边缘不能有毛刺, 覆膜面不能刮花;				名称:	建德C40+潜水俱乐部厨房		
2.公差要求标准: 符合GB/T G3280-2015不锈钢冷轧钢板和钢带标准中PT.A的公称宽度要求;				材料:			
3.所有标注尺寸为外尺寸;				编制:		日期:	
4.未注膜面方向朝外。				审核:		日期:	
A						视角:	☉
版本		批准	日期			版本:	A

STAINLESS STEEL SHOP DRAWING (CUSTOM)

不锈钢件生产要求图

Product Description (产品说明):	4-Tier Square Tube Storage Shelving
	四层通架
Model Type (模具型号):	JFG4 U03

No:	Parts(零部件):	Material Specification(用料标准):
01	COUNTER TOP 柜台面	16GA. THK. SUS 304 S/S
✓ 02	LEG 支腿	∅38mm 16 GA. THK. SUS 304 S/S TUBE
✓ 03	ADJUSTABLE FOOT INSERT 可调节嵌入式底脚	LUI CHUEN KEE (CHN)
04	REINFORCEMENT 加固件	16 GA. THK. SUS 304 S/S
05	SINK BOWL 洗碗槽	16 GA. THK. SUS 304 S/S
06	SINK WASTE 废料槽	
✓ 07	S.S. CROSS RAIL 横梁	∅32mm 16 GA. THK. SUS 304 S/S TUBE
08	WALL MOUNTED BRACKET 壁装托架	16 GA. THK. SUS 304 S/S
09	UNDER SHELF 底架	18 GA. THK. SUS 304 S/S
10	MIXING FAUCET 混合龙头	
11	OVER SHELF 顶架	18 GA. THK. SUS 304 S/S
12	OUTER DOOR PANEL 外板	20 GA. THK. SUS 304 S/S
13	INNER DOOR PANEL 内板	22 GA. THK. SUS 304 S/S
14	CABINET BODY 柜身	20 GA. THK. SUS 304 S/S
15	CORNER BUMPER 拐角防护套	COLSON (CHN)
16	SWIVEL CASTOR 旋转角轮	GLOBE (CHN)
17	SOUND DEADEN MATERIAL 隔音材料	3mm THICKNESS
18	WALL FLASHING 防水面	20 GA. THK. SUS 304 S/S
19	CONDENSING UNIT 制冷机组	DANFOSS (CHN)
20	NOZZLE 排气口	∅25mm SUS 304 S/S TUBE

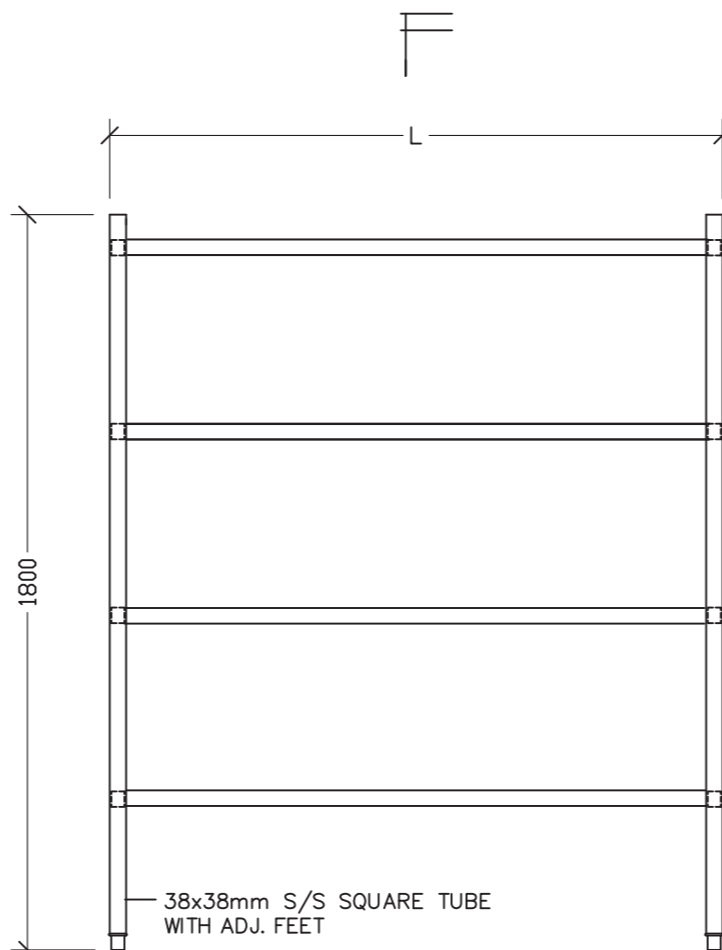

ELEVATION

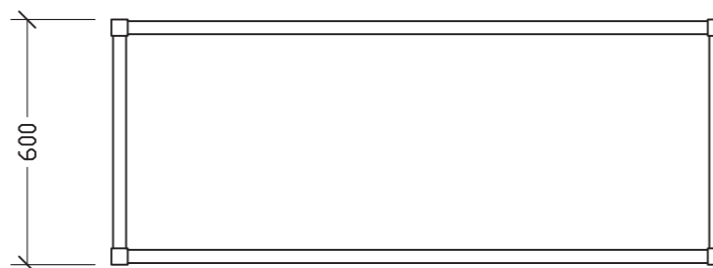

PLAN

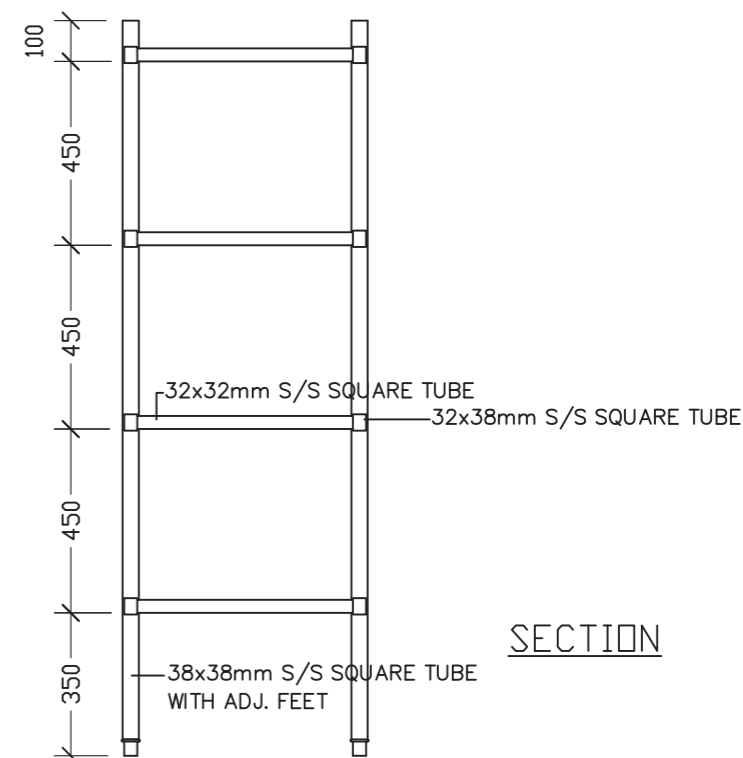

SECTION

No:	Item No(款号):	Qty(数量):	No:	Item No(款号):	Qty(数量):

Remark(备注):



M5

SPOT WELDED A THREADED SHAFT TO THE UNDERSIDE OF WORK TOP / SHELF. THEN USE UNITS TO FIX WITH THE REINFORCEMENT / BRACKETS

技术说明:				SKU:			
1.所有产品边缘不能有毛刺, 覆膜面不能刮花;				名称:	建德C40+潜水俱乐部厨房		
2.公差要求标准: 符合GB/T G3280-2015不锈钢冷轧钢板和钢带标准中PT.A的公称宽度要求;				材料:			
3.所有标注尺寸为外尺寸;				编制:		日期:	
4.未注膜面方向朝外。				审核:		日期:	
A						视角:	☉
版本		批准	日期			版本:	A

STAINLESS STEEL SHOP DRAWING (CUSTOM)

不锈钢件生产要求图

Product Description (产品说明):	Work Cabinet
	工作掩门柜
Model Type (模具型号):	CBH U04

No:	Parts(零部件):	Material Specification(用料标准):
✓ 01	COUNTER TOP 柜台面	16GA. THK. SUS 304 S/S
02	LEG 支腿	Ø38mm 16 GA. THK. SUS 304 S/S TUBE
✓ 03	ADJUSTABLE FOOT INSERT 可调节嵌入式底脚	LUI CHUEN KEE (CHN)
✓ 04	REINFORCEMENT 加固件	16 GA. THK. SUS 304 S/S
05	SINK BOWL 洗碗槽	16 GA. THK. SUS 304 S/S
06	SINK WASTE 废料槽	
07	S.S. CROSS RAIL 横梁	Ø32mm 16 GA. THK. SUS 304 S/S TUBE
08	WALL MOUNTED BRACKET 壁装托架	16 GA. THK. SUS 304 S/S
✓ 09	UNDER SHELF 底架	18 GA. THK. SUS 304 S/S
10	MIXING FAUCET 混合龙头	
11	OVER SHELF 顶架	18 GA. THK. SUS 304 S/S
✓ 12	OUTER DOOR PANEL 外板	20 GA. THK. SUS 304 S/S
✓ 13	INNER DOOR PANEL 内板	22 GA. THK. SUS 304 S/S
✓ 14	CABINET BODY 柜身	20 GA. THK. SUS 304 S/S
15	CORNER BUMPER 拐角防护套	COLSON (CHN)
16	SWIVEL CASTOR 旋转角轮	GLOBE (CHN)
17	SOUND DEADEN MATERIAL 隔音材料	3mm THICKNESS
18	WALL FLASHING 防水面	20 GA. THK. SUS 304 S/S
19	CONDENSING UNIT 制冷机组	DANFOSS (CHN)
20	NOZZLE 排气口	Ø25mm SUS 304 S/S TUBE

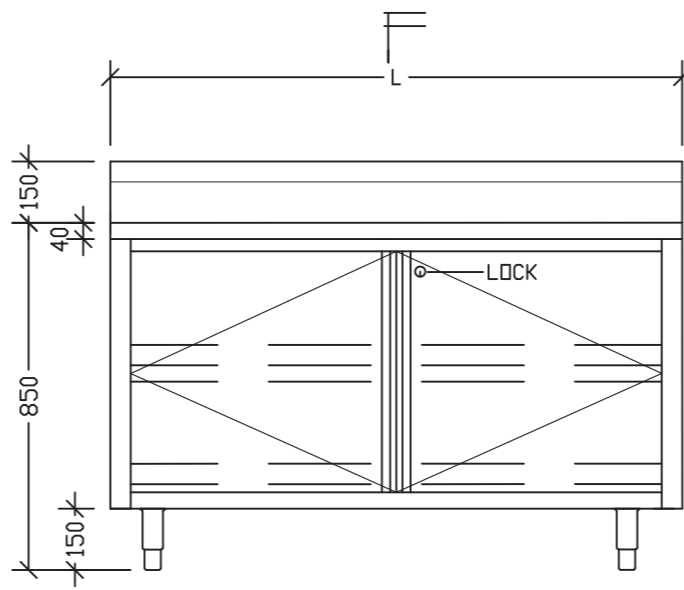

ELEVATION

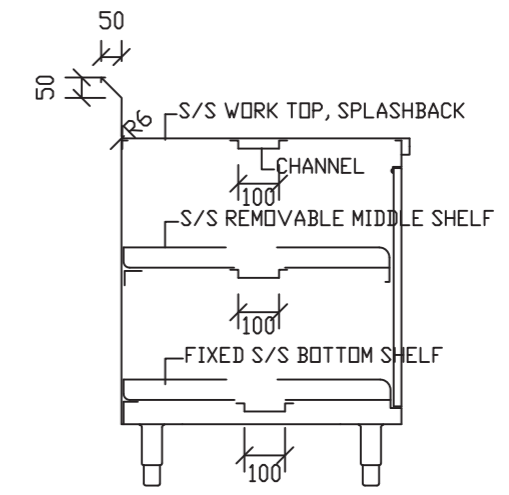

SECTION

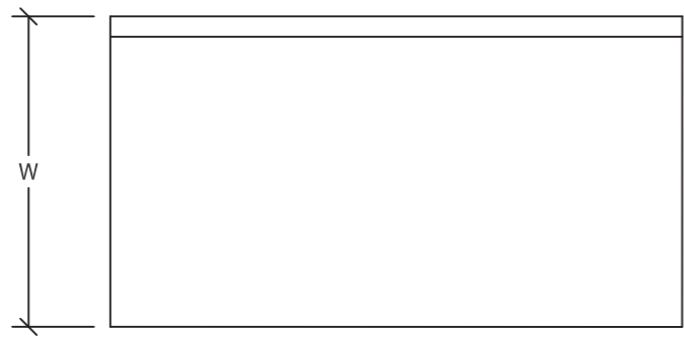

PLAN

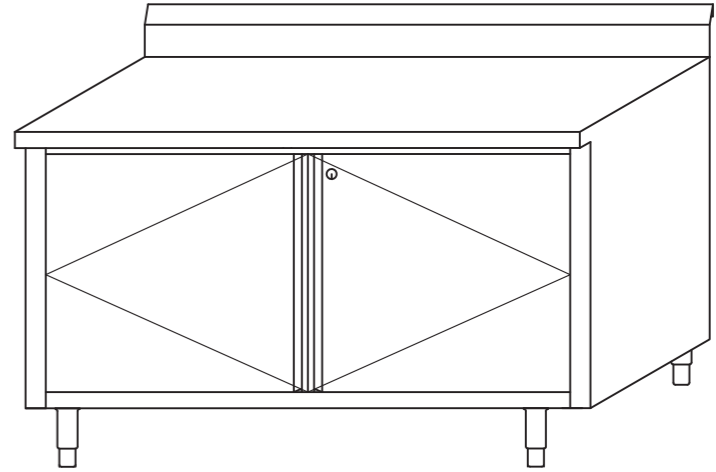

ISOMETRIC VIEW

No:	Item No(款号):	Qty(数量):	No:	Item No(款号):	Qty(数量):

Remark(备注):



SPOT WELDED A THREADED SHAFT TO THE UNDERSIDE OF WORK TOP / SHELF. THEN USE UNITS TO FIX WITH THE REINFORCEMENT / BRACKETS

技术说明:				SKU:			
1.所有产品边缘不能有毛刺, 覆膜面不能刮花;				名称:	建德C40+潜水俱乐部厨房		
2.公差要求标准: 符合GB/T G3280-2015不锈钢冷轧钢板和钢带标准中PT.A的公称宽度要求;				材料:			
3.所有标注尺寸为外尺寸;				编制:		日期:	
4.未注膜面方向朝外。				审核:		日期:	
A						视角:	☉
版本			批准	日期		版本:	A

STAINLESS STEEL SHOP DRAWING (CUSTOM)

不锈钢件生产要求图

Product Description (产品说明):	Wash Sink
	三星
Model Type (模具型号):	SPSC3P U05

No:	Parts(零部件):	Material Specification(用料标准):
✓ 01	COUNTER TOP 柜台面	16GA. THK. SUS 304 S/S
✓ 02	LEG 支腿	∅38mm 16 GA. THK. SUS 304 S/S TUBE
✓ 03	ADJUSTABLE FOOT INSERT 可调节嵌入式底脚	LUI CHUEN KEE (CHN)
✓ 04	REINFORCEMENT 加固件	16 GA. THK. SUS 304 S/S
✓ 05	SINK BOWL 洗碗槽	16 GA. THK. SUS 304 S/S
06	SINK WASTE 废料槽	
✓ 07	S.S. CROSS RAIL 横梁	∅32mm 16 GA. THK. SUS 304 S/S TUBE
08	WALL MOUNTED BRACKET 壁挂托架	16 GA. THK. SUS 304 S/S
09	UNDER SHELF 底架	18 GA. THK. SUS 304 S/S
✓ 10	MIXING FAUCET 混合龙头	
✓ 11	OVER SHELF 顶架	18 GA. THK. SUS 304 S/S
12	OUTER DOOR PANEL 外板	20 GA. THK. SUS 304 S/S
13	INNER DOOR PANEL 内板	22 GA. THK. SUS 304 S/S
14	CABINET BODY 柜身	20 GA. THK. SUS 304 S/S
15	CORNER BUMPER 拐角防护套	COLSON (CHN)
16	SWIVEL CASTOR 旋转角轮	GLOBE (CHN)
17	SOUND DEADEN MATERIAL 隔音材料	3mm THICKNESS
18	WALL FLASHING 防水面	20 GA. THK. SUS 304 S/S
19	CONDENSING UNIT 制冷机组	DANFOSS (CHN)
20	NOZZLE 排气口	∅25mm SUS 304 S/S TUBE

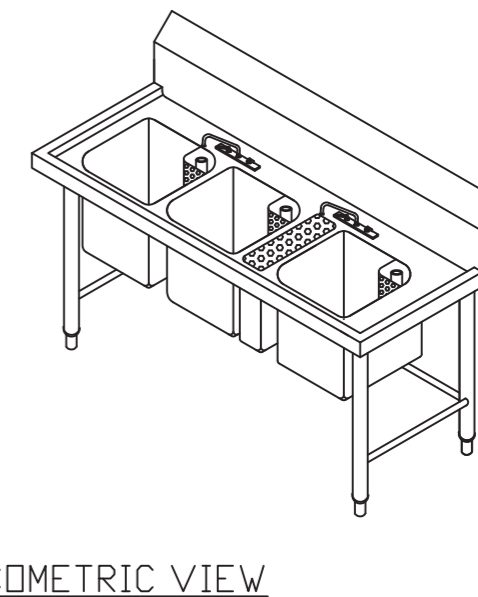
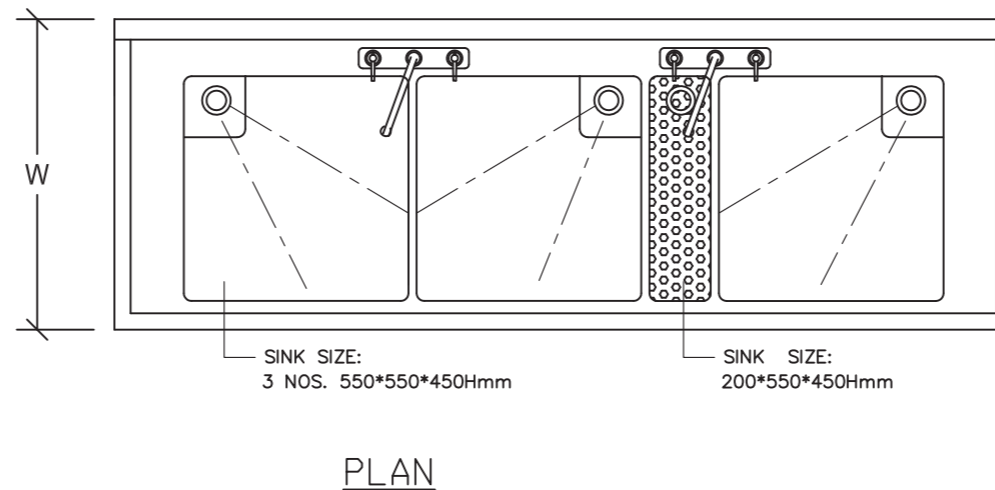
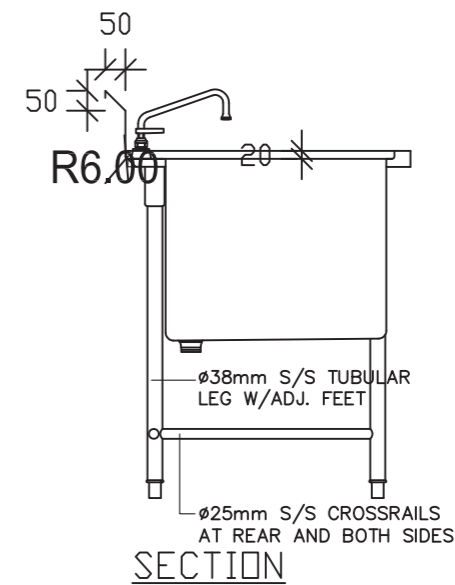
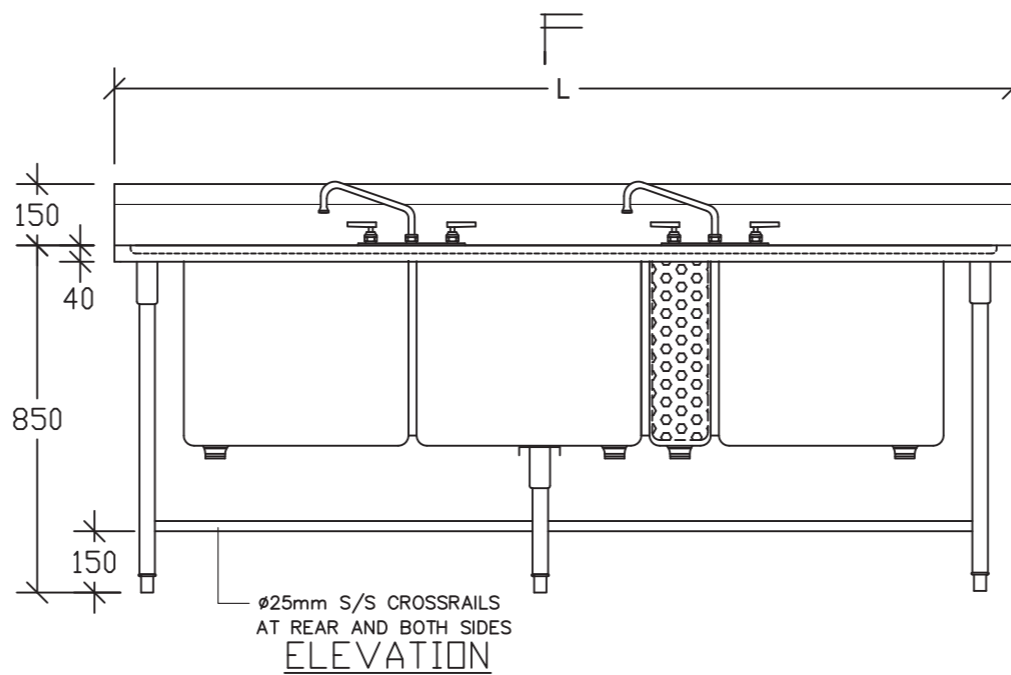

No:	Item No(款号):	Qty(数量):	No:	Item No(款号):	Qty(数量):

Remark(备注):



SPOT WELDED A THREADED SHAFT TO THE UNDERSIDE OF WORK TOP / SHELF. THEN USE UNITS TO FIX WITH THE REINFORCEMENT / BRACKETS

技术说明:				SKU:			
1.所有产品边缘不能有毛刺, 覆膜面不能刮花;				名称:	建德C40+潜水俱乐部厨房		
2.公差要求标准: 符合GB/T G3280-2015不锈钢冷轧钢板和钢带标准中PT.A的公称宽度要求;				材料:			
3.所有标注尺寸为外尺寸;				编制:		日期:	
4.未注膜面方向朝外。				审核:		日期:	
A						视角:	☉
版本		批准	日期			版本:	A

STAINLESS STEEL SHOP DRAWING (CUSTOM)

不锈钢件生产要求图

Product Description (产品说明):	Single Wall Mounted Shelving
	单层挂墙层架
Model Type (模具型号):	JBW1 U06

No:	Parts(零部件):	Material Specification(用料标准):
01	COUNTER TOP 柜台面	16GA. THK. SUS 304 S/S
02	LEG 支腿	∅38mm 16 GA. THK. SUS 304 S/S TUBE
03	ADJUSTABLE FOOT INSERT 可调节嵌入式底脚	LUI CHUEN KEE (CHN)
✓ 04	REINFORCEMENT 加固件	16 GA. THK. SUS 304 S/S
05	SINK BOWL 洗碗槽	16 GA. THK. SUS 304 S/S
06	SINK WASTE 废料槽	
07	S.S. CROSS RAIL 横梁	∅32mm 16 GA. THK. SUS 304 S/S TUBE
✓ 08	WALL MOUNTED BRACKET 壁装托架	16 GA. THK. SUS 304 S/S
09	UNDER SHELF 底架	18 GA. THK. SUS 304 S/S
10	MIXING FAUCET 混合龙头	
✓ 11	OVER SHELF 顶架	18 GA. THK. SUS 304 S/S
12	OUTER DOOR PANEL 外板	20 GA. THK. SUS 304 S/S
13	INNER DOOR PANEL 内板	22 GA. THK. SUS 304 S/S
14	CABINET BODY 柜身	20 GA. THK. SUS 304 S/S
15	CORNER BUMPER 拐角防护套	COLSON (CHN)
16	SWIVEL CASTOR 旋转角轮	GLOBE (CHN)
17	SOUND DEADEN MATERIAL 隔音材料	3mm THICKNESS
18	WALL FLASHING 防水面	20 GA. THK. SUS 304 S/S
19	CONDENSING UNIT 制冷机组	DANFOSS (CHN)
20	NOZZLE 排气口	∅25mm SUS 304 S/S TUBE

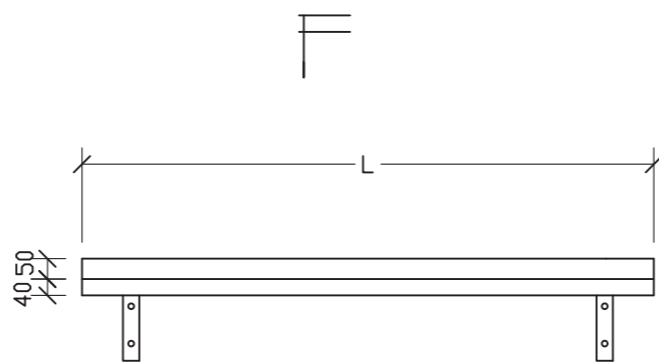

ELEVATION

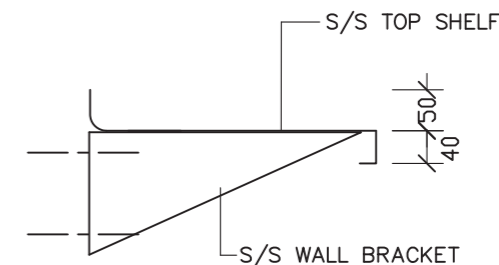

SECTION

No:	Item No(款号):	Qty(数量):	No:	Item No(款号):	Qty(数量):

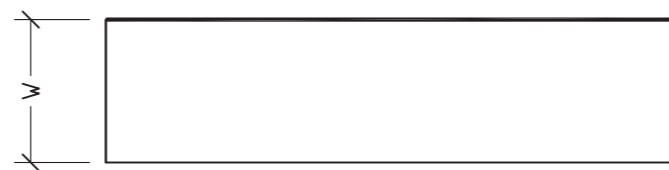

PLAN

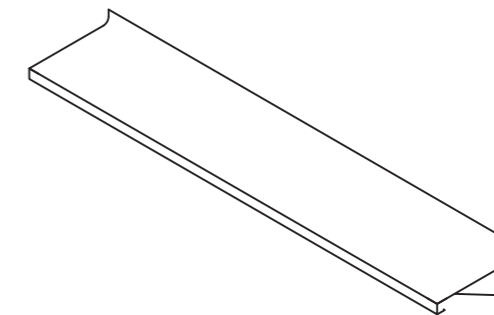

ISOMETRIC VIEW

Remark(备注):



SPOT WELDED A THREADED SHAFT TO THE UNDERSIDE OF WORK TOP / SHELF. THEN USE UNITS TO FIX WITH THE REINFORCEMENT / BRACKETS

技术说明:				SKU:			
1.所有产品边缘不能有毛刺, 覆膜面不能刮花;				名称:	建德C40+潜水俱乐部厨房		
2.公差要求标准: 符合GB/T G3280-2015不锈钢冷轧钢板和钢带标准中PT.A的公称宽度要求;				材料:			
3.所有标注尺寸为外尺寸;				编制:		日期:	
4.未注膜面方向朝外。				审核:		日期:	
A						视角:	☉
版本		批准	日期			版本:	A

STAINLESS STEEL SHOP DRAWING (CUSTOM)

不锈钢件生产要求图

Product Description (产品说明):	Work Cabinet
	工作掩门柜
Model Type (模具型号):	CBH U09

No:	Parts(零部件):	Material Specification(用料标准):
✓ 01	COUNTER TOP 柜台面	16GA. THK. SUS 304 S/S
02	LEG 支腿	Ø38mm 16 GA. THK. SUS 304 S/S TUBE
✓ 03	ADJUSTABLE FOOT INSERT 可调节嵌入式底脚	LUI CHUEN KEE (CHN)
✓ 04	REINFORCEMENT 加固件	16 GA. THK. SUS 304 S/S
05	SINK BOWL 洗碗槽	16 GA. THK. SUS 304 S/S
06	SINK WASTE 废料槽	
07	S.S. CROSS RAIL 横梁	Ø32mm 16 GA. THK. SUS 304 S/S TUBE
08	WALL MOUNTED BRACKET 壁装托架	16 GA. THK. SUS 304 S/S
✓ 09	UNDER SHELF 底架	18 GA. THK. SUS 304 S/S
10	MIXING FAUCET 混合龙头	
11	OVER SHELF 顶架	18 GA. THK. SUS 304 S/S
✓ 12	OUTER DOOR PANEL 外板	20 GA. THK. SUS 304 S/S
✓ 13	INNER DOOR PANEL 内板	22 GA. THK. SUS 304 S/S
✓ 14	CABINET BODY 柜身	20 GA. THK. SUS 304 S/S
15	CORNER BUMPER 拐角防护套	COLSON (CHN)
16	SWIVEL CASTOR 旋转角轮	GLOBE (CHN)
17	SOUND DEADEN MATERIAL 隔音材料	3mm THICKNESS
18	WALL FLASHING 防水面	20 GA. THK. SUS 304 S/S
19	CONDENSING UNIT 制冷机组	DANFOSS (CHN)
20	NOZZLE 排气口	Ø25mm SUS 304 S/S TUBE

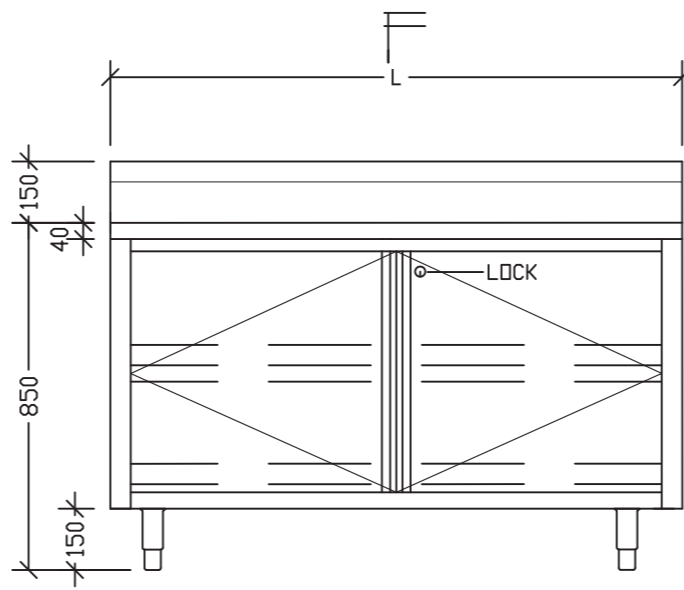

ELEVATION

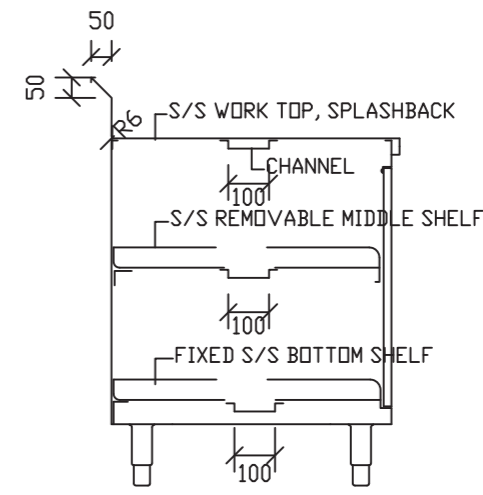

SECTION

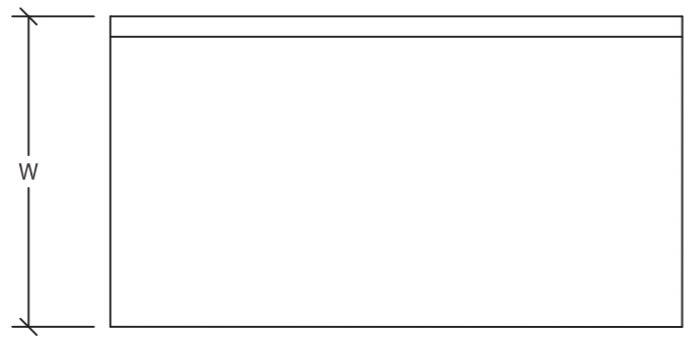

PLAN

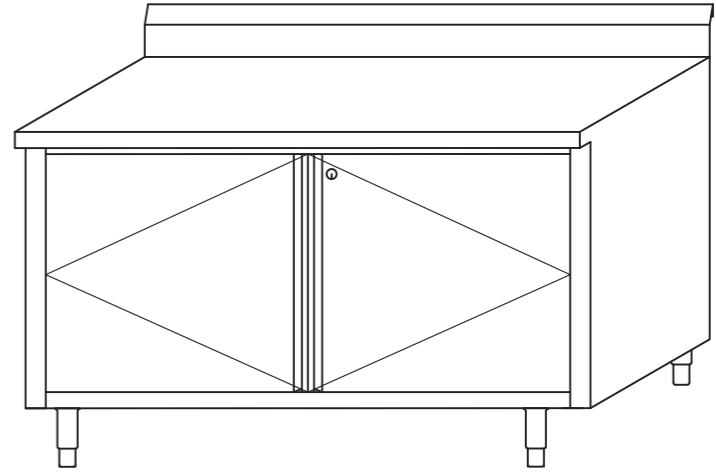

ISOMETRIC VIEW

No:	Item No(款号):	Qty(数量):	No:	Item No(款号):	Qty(数量):

Remark(备注):



SPOT WELDED A THREADED SHAFT TO THE UNDERSIDE OF WORK TOP / SHELF. THEN USE UNITS TO FIX WITH THE REINFORCEMENT / BRACKETS

技术说明:				SKU:			
1.所有产品边缘不能有毛刺, 覆膜面不能刮花;				名称:	建德C40+潜水俱乐部厨房		
2.公差要求标准: 符合GB/T G3280-2015不锈钢冷轧钢板和钢带标准中PT.A的公称宽度要求;				材料:			
3.所有标注尺寸为外尺寸;				编制:		日期:	
4.未注膜面方向朝外。				审核:		日期:	
A						视角:	☉
版本			批准	日期		版本:	A

STAINLESS STEEL SHOP DRAWING (CUSTOM)

不锈钢件生产要求图

Product Description (产品说明):	Single Wall Mounted Shelving
	单层挂墙层架
Model Type (模具型号):	JBW1 U10

No:	Parts(零部件):	Material Specification(用料标准):
01	COUNTER TOP 柜台面	16GA. THK. SUS 304 S/S
02	LEG 支腿	∅38mm 16 GA. THK. SUS 304 S/S TUBE
03	ADJUSTABLE FOOT INSERT 可调节嵌入式底脚	LUI CHUEN KEE (CHN)
✓ 04	REINFORCEMENT 加固件	16 GA. THK. SUS 304 S/S
05	SINK BOWL 洗碗槽	16 GA. THK. SUS 304 S/S
06	SINK WASTE 废料槽	
07	S.S. CROSS RAIL 横梁	∅32mm 16 GA. THK. SUS 304 S/S TUBE
✓ 08	WALL MOUNTED BRACKET 壁装托架	16 GA. THK. SUS 304 S/S
09	UNDER SHELF 底架	18 GA. THK. SUS 304 S/S
10	MIXING FAUCET 混合龙头	
✓ 11	OVER SHELF 顶架	18 GA. THK. SUS 304 S/S
12	OUTER DOOR PANEL 外板	20 GA. THK. SUS 304 S/S
13	INNER DOOR PANEL 内板	22 GA. THK. SUS 304 S/S
14	CABINET BODY 柜身	20 GA. THK. SUS 304 S/S
15	CORNER BUMPER 拐角防护套	COLSON (CHN)
16	SWIVEL CASTOR 旋转角轮	GLOBE (CHN)
17	SOUND DEADEN MATERIAL 隔音材料	3mm THICKNESS
18	WALL FLASHING 防水面	20 GA. THK. SUS 304 S/S
19	CONDENSING UNIT 制冷机组	DANFOSS (CHN)
20	NOZZLE 排气口	∅25mm SUS 304 S/S TUBE

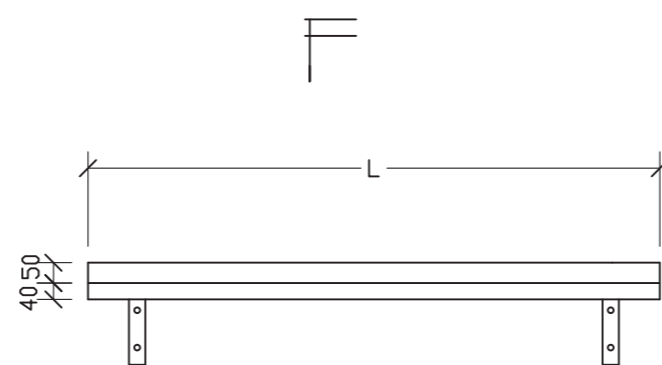

ELEVATION

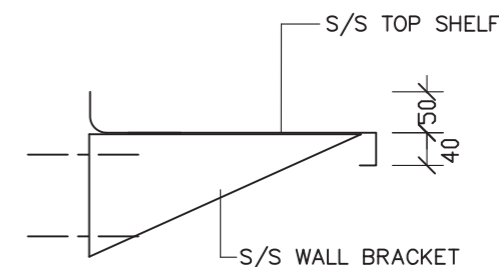

SECTION

No:	Item No(款号):	Qty(数量):	No:	Item No(款号):	Qty(数量):

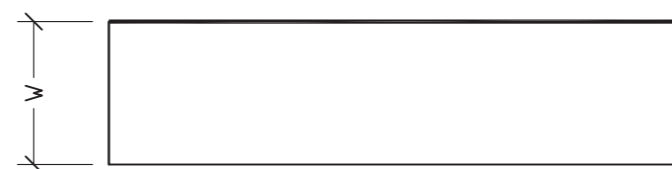

PLAN

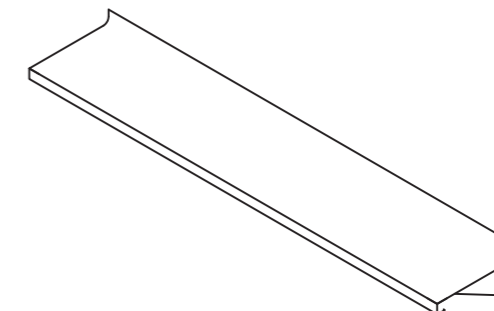

ISOMETRIC VIEW

Remark(备注):



SPOT WELDED A THREADED SHAFT TO THE UNDERSIDE OF WORK TOP / SHELF. THEN USE UNITS TO FIX WITH THE REINFORCEMENT / BRACKETS

技术说明:				SKU:			
1.所有产品边缘不能有毛刺, 覆膜面不能刮花;				名称:	建德C40+潜水俱乐部厨房		
2.公差要求标准: 符合GB/T G3280-2015不锈钢冷轧钢板和钢带标准中PT.A的公称宽度要求;				材料:			
3.所有标注尺寸为外尺寸;				编制:		日期:	
4.未注膜面方向朝外。				审核:		日期:	
A						视角:	☉
版本		批准	日期			版本:	A

STAINLESS STEEL SHOP DRAWING (CUSTOM)

不锈钢件生产要求图

Product Description (产品说明):	Work Cabinet
	工作掩门柜
Model Type (模具型号):	CBH U13

No:	Parts(零部件):	Material Specification(用料标准):
✓ 01	COUNTER TOP 柜台面	16GA. THK. SUS 304 S/S
02	LEG 支腿	Ø38mm 16 GA. THK. SUS 304 S/S TUBE
✓ 03	ADJUSTABLE FOOT INSERT 可调节嵌入式底脚	LUI CHUEN KEE (CHN)
✓ 04	REINFORCEMENT 加固件	16 GA. THK. SUS 304 S/S
05	SINK BOWL 洗碗槽	16 GA. THK. SUS 304 S/S
06	SINK WASTE 废料槽	
07	S.S. CROSS RAIL 横梁	Ø32mm 16 GA. THK. SUS 304 S/S TUBE
08	WALL MOUNTED BRACKET 壁装托架	16 GA. THK. SUS 304 S/S
✓ 09	UNDER SHELF 底架	18 GA. THK. SUS 304 S/S
10	MIXING FAUCET 混合龙头	
11	OVER SHELF 顶架	18 GA. THK. SUS 304 S/S
✓ 12	OUTER DOOR PANEL 外板	20 GA. THK. SUS 304 S/S
✓ 13	INNER DOOR PANEL 内板	22 GA. THK. SUS 304 S/S
✓ 14	CABINET BODY 柜身	20 GA. THK. SUS 304 S/S
15	CORNER BUMPER 拐角防护套	COLSON (CHN)
16	SWIVEL CASTOR 旋转角轮	GLOBE (CHN)
17	SOUND DEADEN MATERIAL 隔音材料	3mm THICKNESS
18	WALL FLASHING 防水面	20 GA. THK. SUS 304 S/S
19	CONDENSING UNIT 制冷机组	DANFOSS (CHN)
20	NOZZLE 排气口	Ø25mm SUS 304 S/S TUBE

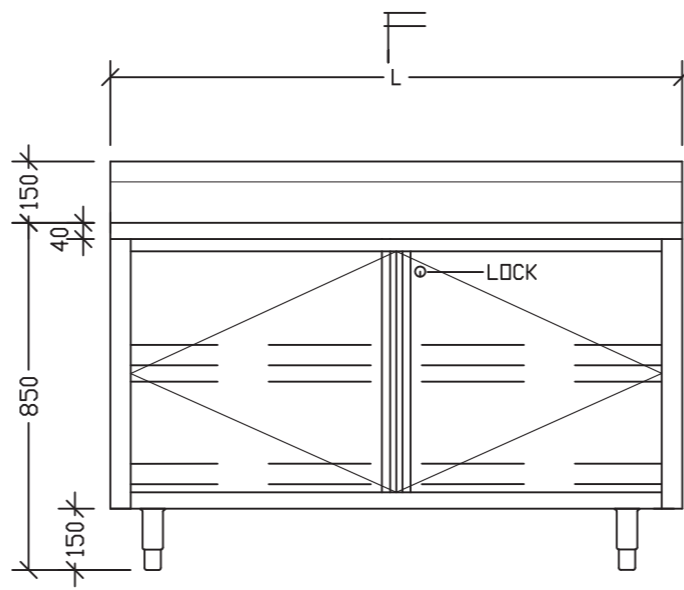

ELEVATION

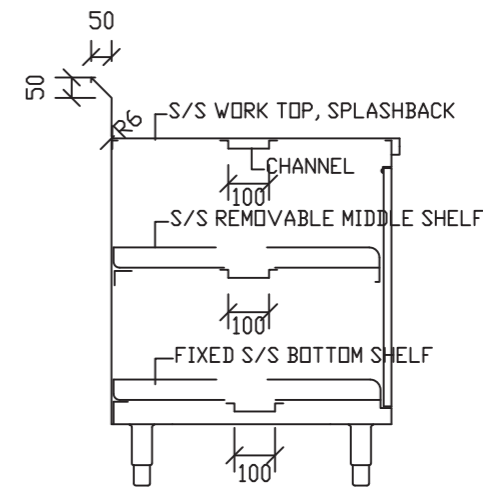

SECTION

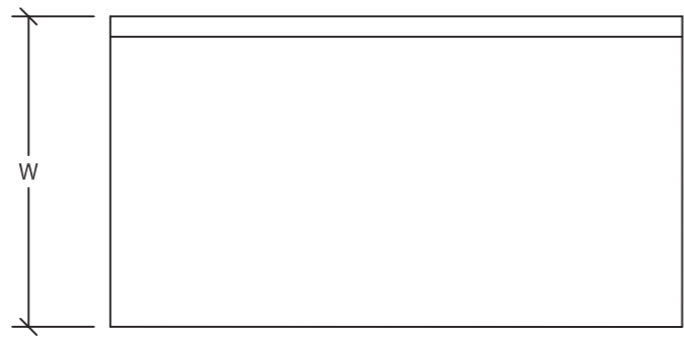

PLAN

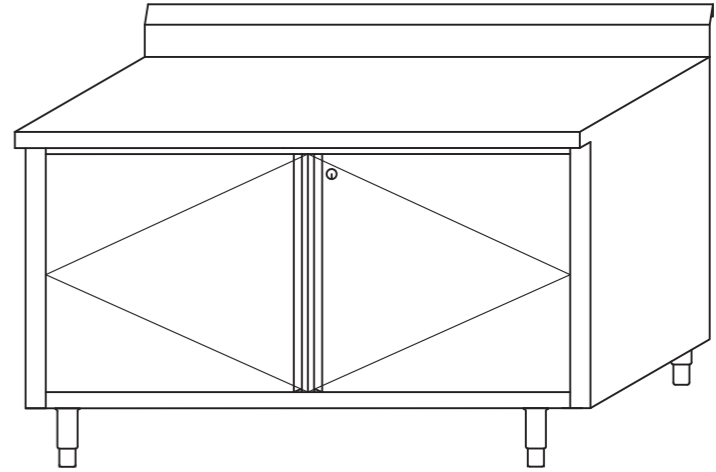

ISOMETRIC VIEW

No:	Item No(款号):	Qty(数量):	No:	Item No(款号):	Qty(数量):

Remark(备注):



SPOT WELDED A THREADED SHAFT TO THE UNDERSIDE OF WORK TOP / SHELF. THEN USE UNITS TO FIX WITH THE REINFORCEMENT / BRACKETS

技术说明:				SKU:			
1.所有产品边缘不能有毛刺, 覆膜面不能刮花;				名称:	建德C40+潜水俱乐部厨房		
2.公差要求标准: 符合GB/T G3280-2015不锈钢冷轧钢板和钢带标准中PT.A的公称宽度要求;				材料:			
3.所有标注尺寸为外尺寸;				编制:		日期:	
4.未注膜面方向朝外。				审核:		日期:	
A						视角:	☉
版本			批准	日期		版本:	A

STAINLESS STEEL SHOP DRAWING (CUSTOM)

不锈钢件生产要求图

Product Description (产品说明):	Single Wall Mounted Shelving
	单层挂墙层架
Model Type (模具型号):	JBW1 U14

No:	Parts(零部件):	Material Specification(用料标准):
01	COUNTER TOP 柜台面	16GA. THK. SUS 304 S/S
02	LEG 支腿	∅38mm 16 GA. THK. SUS 304 S/S TUBE
03	ADJUSTABLE FOOT INSERT 可调节嵌入式底脚	LUI CHUEN KEE (CHN)
✓ 04	REINFORCEMENT 加固件	16 GA. THK. SUS 304 S/S
05	SINK BOWL 洗碗槽	16 GA. THK. SUS 304 S/S
06	SINK WASTE 废料槽	
07	S.S. CROSS RAIL 横梁	∅32mm 16 GA. THK. SUS 304 S/S TUBE
✓ 08	WALL MOUNTED BRACKET 壁装托架	16 GA. THK. SUS 304 S/S
09	UNDER SHELF 底架	18 GA. THK. SUS 304 S/S
10	MIXING FAUCET 混合龙头	
✓ 11	OVER SHELF 顶架	18 GA. THK. SUS 304 S/S
12	OUTER DOOR PANEL 外板	20 GA. THK. SUS 304 S/S
13	INNER DOOR PANEL 内板	22 GA. THK. SUS 304 S/S
14	CABINET BODY 柜身	20 GA. THK. SUS 304 S/S
15	CORNER BUMPER 拐角防护套	COLSON (CHN)
16	SWIVEL CASTOR 旋转角轮	GLOBE (CHN)
17	SOUND DEADEN MATERIAL 隔音材料	3mm THICKNESS
18	WALL FLASHING 防水面	20 GA. THK. SUS 304 S/S
19	CONDENSING UNIT 制冷机组	DANFOSS (CHN)
20	NOZZLE 排气口	∅25mm SUS 304 S/S TUBE

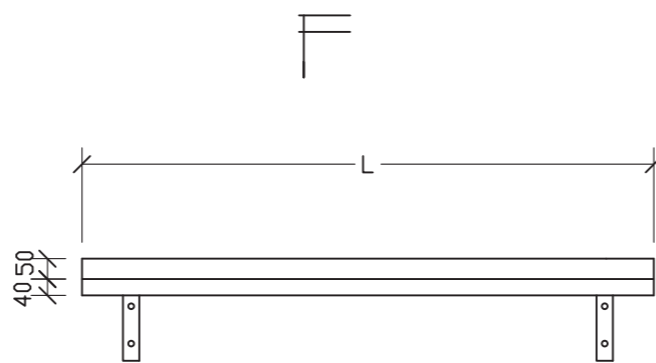

ELEVATION

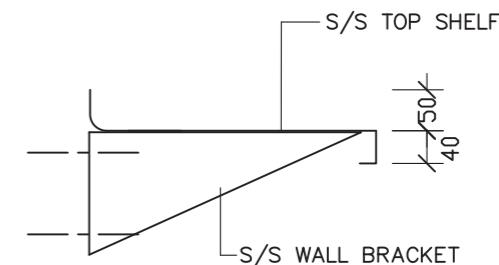

SECTION

No:	Item No(款号):	Qty(数量):	No:	Item No(款号):	Qty(数量):

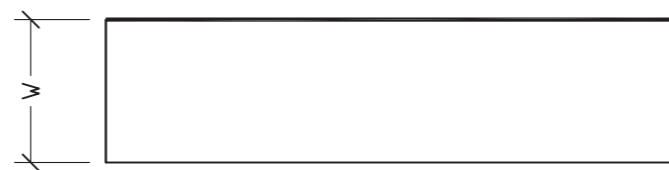

PLAN

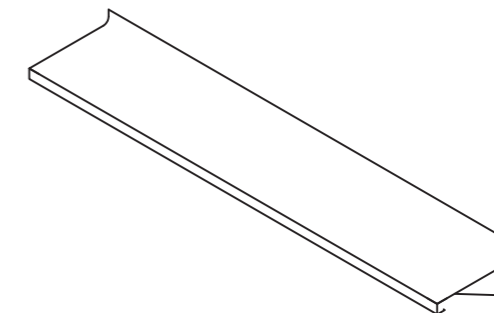

ISOMETRIC VIEW

Remark(备注):



SPOT WELDED A THREADED SHAFT TO THE UNDERSIDE OF WORK TOP / SHELF. THEN USE UNITS TO FIX WITH THE REINFORCEMENT / BRACKETS

技术说明:				SKU:			
1.所有产品边缘不能有毛刺, 覆膜面不能刮花;				名称:	建德C40+潜水俱乐部厨房		
2.公差要求标准: 符合GB/T G3280-2015不锈钢冷轧钢板和钢带标准中PT.A的公称宽度要求;				材料:			
3.所有标注尺寸为外尺寸;				编制:		日期:	
4.未注膜面方向朝外。				审核:		日期:	
A						视角:	☉ ☒
版本		批准	日期			版本:	A

STAINLESS STEEL SHOP DRAWING (CUSTOM)

不锈钢件生产要求图

Product Description (产品说明):	Work Cabinet
	工作掩门柜
Model Type (模具型号):	CBH U15

No:	Parts(零部件):	Material Specification(用料标准):
✓ 01	COUNTER TOP 柜台面	16GA. THK. SUS 304 S/S
02	LEG 支腿	Ø38mm 16 GA. THK. SUS 304 S/S TUBE
✓ 03	ADJUSTABLE FOOT INSERT 可调节嵌入式底脚	LUI CHUEN KEE (CHN)
✓ 04	REINFORCEMENT 加固件	16 GA. THK. SUS 304 S/S
05	SINK BOWL 洗碗槽	16 GA. THK. SUS 304 S/S
06	SINK WASTE 废料槽	
07	S.S. CROSS RAIL 横梁	Ø32mm 16 GA. THK. SUS 304 S/S TUBE
08	WALL MOUNTED BRACKET 壁装托架	16 GA. THK. SUS 304 S/S
✓ 09	UNDER SHELF 底架	18 GA. THK. SUS 304 S/S
10	MIXING FAUCET 混合龙头	
11	OVER SHELF 顶架	18 GA. THK. SUS 304 S/S
✓ 12	OUTER DOOR PANEL 外板	20 GA. THK. SUS 304 S/S
✓ 13	INNER DOOR PANEL 内板	22 GA. THK. SUS 304 S/S
✓ 14	CABINET BODY 柜身	20 GA. THK. SUS 304 S/S
15	CORNER BUMPER 拐角防护套	COLSON (CHN)
16	SWIVEL CASTOR 旋转角轮	GLOBE (CHN)
17	SOUND DEADEN MATERIAL 隔音材料	3mm THICKNESS
18	WALL FLASHING 防水面	20 GA. THK. SUS 304 S/S
19	CONDENSING UNIT 制冷机组	DANFOSS (CHN)
20	NOZZLE 排气口	Ø25mm SUS 304 S/S TUBE

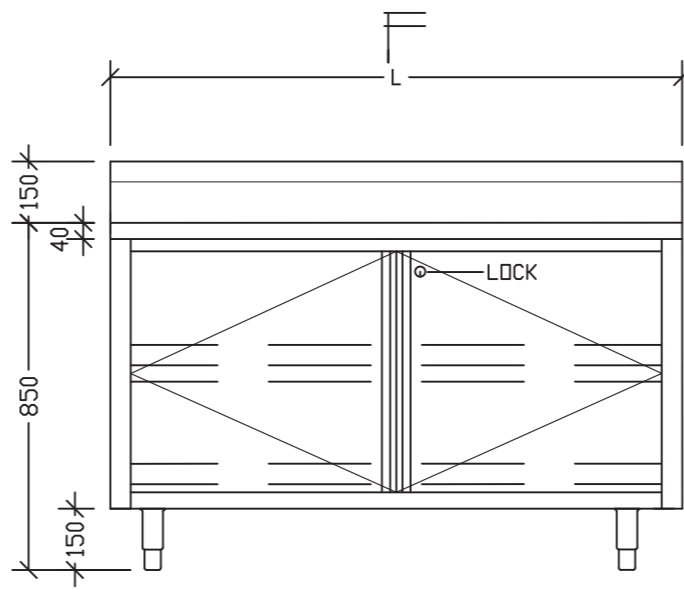

ELEVATION

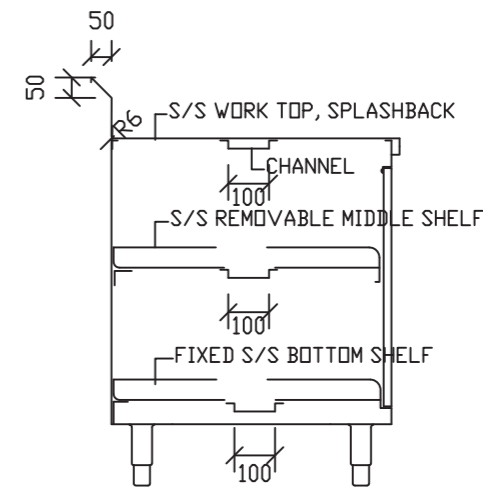

SECTION

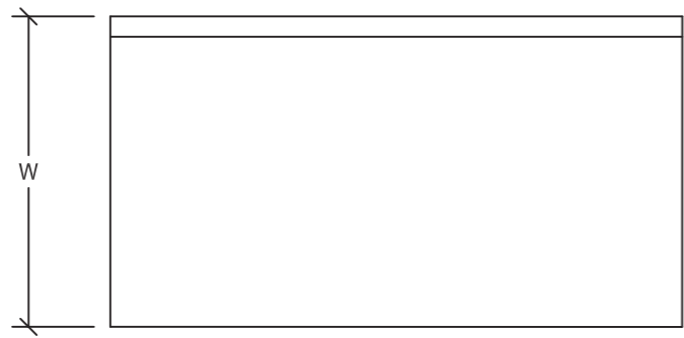

PLAN

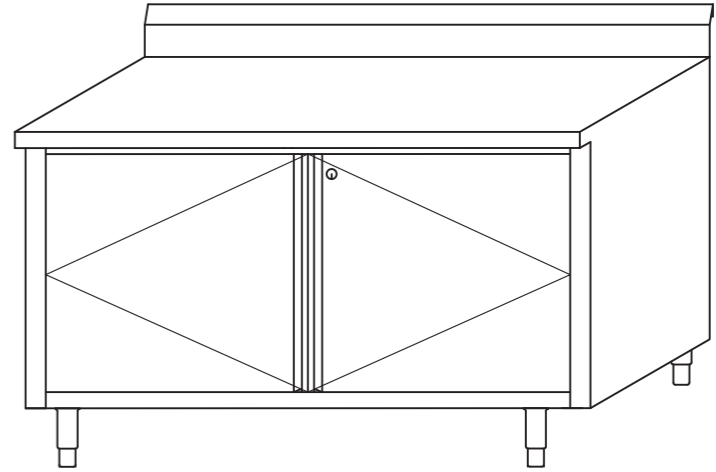

ISOMETRIC VIEW

No:	Item No(款号):	Qty(数量):	No:	Item No(款号):	Qty(数量):

Remark(备注):



SPOT WELDED A THREADED SHAFT TO THE UNDERSIDE OF WORK TOP / SHELF. THEN USE UNITS TO FIX WITH THE REINFORCEMENT / BRACKETS

技术说明:				SKU:			
1.所有产品边缘不能有毛刺, 覆膜面不能刮花;				名称:	建德C40+潜水俱乐部厨房		
2.公差要求标准: 符合GB/T G3280-2015不锈钢冷轧钢板和钢带标准中PT.A的公称宽度要求;				材料:			
3.所有标注尺寸为外尺寸;				编制:		日期:	
4.未注膜面方向朝外。				审核:		日期:	
A						视角:	☉
版本			批准	日期		版本:	A

STAINLESS STEEL SHOP DRAWING (CUSTOM)

不锈钢件生产要求图

Product Description (产品说明):	Pass- Thru Cabinet
	传菜窗柜
Model Type (模具型号):	ZWD

No:	Parts(零部件):	Material Specfication(用料标准):
01	COUNTER TOP 柜台面	16GA. THK. SUS 304 S/S
02	LEG 支腿	Ø38mm 16 GA. THK. SUS 304 S/S TUBE
✓ 03	ADJUSTABLE FOOT INSERT 可调节嵌入式底脚	LUI CHUEN KEE (CHN)
✓ 04	REINFORCEMENT 加固件	16 GA. THK. SUS 304 S/S
05	SINK BOWL 洗碗槽	16 GA. THK. SUS 304 S/S
06	SINK WASTE 废料槽	
07	S.S. CROSS RAIL 横梁	Ø32mm 16 GA. THK. SUS 304 S/S TUBE
08	WALL MOUNTED BRACKET 壁装托架	16 GA. THK. SUS 304 S/S
✓ 09	UNDER SHELF 底架	18 GA. THK. SUS 304 S/S
✓ 10	MIXING FAUCET 混合龙头	
✓ 11	OVER SHELF 顶架	18 GA. THK. SUS 304 S/S
✓ 12	OUTER DOOR PANEL 外板	20 GA. THK. SUS 304 S/S
✓ 13	INNER DOOR PANEL 内板	22 GA. THK. SUS 304 S/S
✓ 14	CABINET BODY 柜身	20 GA. THK. SUS 304 S/S
15	CORNER BUMPER 拐角防护套	COLSON (CHN)
16	SWIVEL CASTOR 旋转角轮	GLOBE (CHN)
17	SOUND DEADEN MATERIAL 隔音材料	3mm THICKNESS
18	WALL FLASHING 防水面	20 GA. THK. SUS 304 S/S
19	CONDENSING UNIT 制冷机组	DANFOSS (CHN)
20	NOZZLE 排气口	Ø25mm SUS 304 S/S TUBE

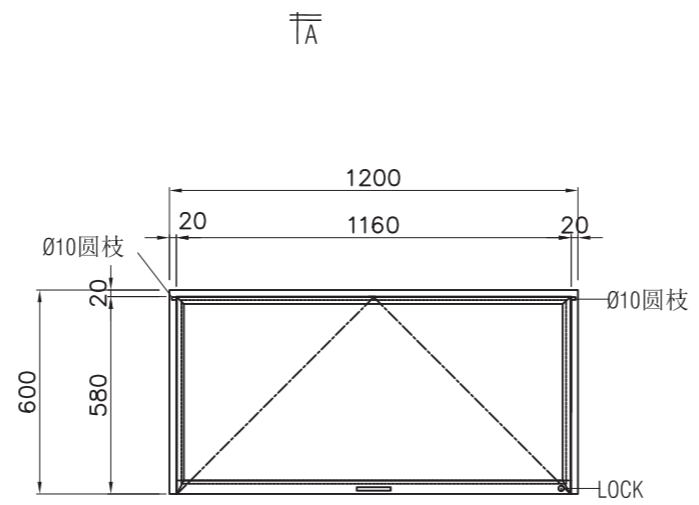

ELEVATION 01

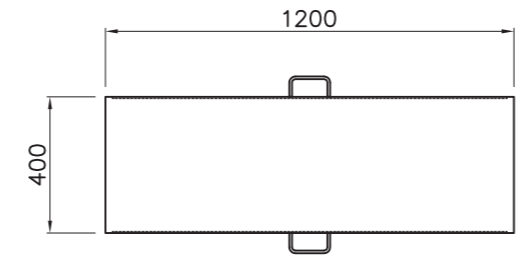

PLAN

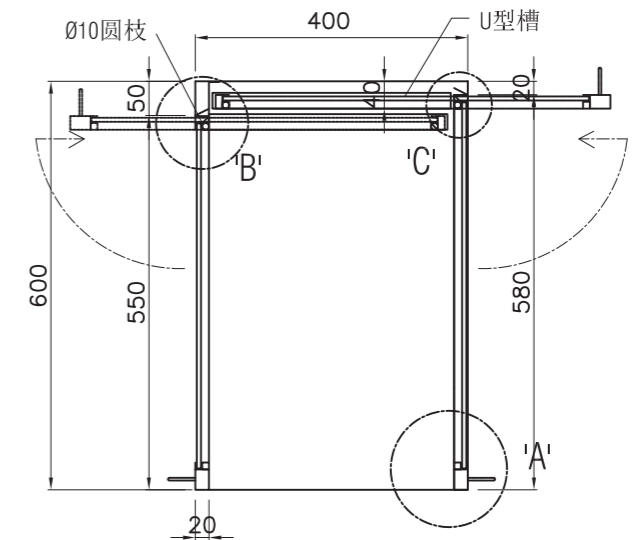

SECTION A

SCALE 1:10

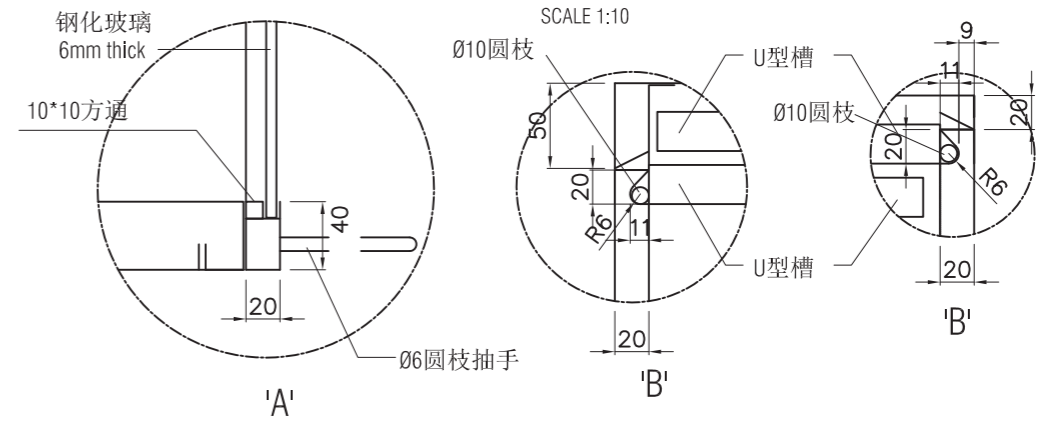

No:	Item No(款号):	Qty(数量):	No:	Item No(款号):	Qty(数量):

Remark(备注):

 M5

SPOT WELDED A THREADED SHAFT TO THE UNDERSIDE OF WORK TOP / SHELF. THEN USE UNITS TO FIX WITH THE REINFORCEMENT / BRACKETS

技术说明:				SKU:			
1.所有产品边缘不能有毛刺, 覆膜面不能刮花;				名称:	建德C40+潜水俱乐部厨房		
2.公差要求标准: 符合GB/T G3280-2015不锈钢冷轧钢板和钢带标准中PT.A的公称宽度要求;				材料:			
3.所有标注尺寸为外尺寸;				编制:		日期:	
4.未注膜面方向朝外。				审核:		日期:	
A						视角:	
版本		批准	日期			版本:	A

STAINLESS STEEL SHOP DRAWING (CUSTOM)

不锈钢件生产要求图

Product Description (产品说明):	Work Table
	残菜回收台
Model Type (模具型号):	TB V02

No:	Parts(零部件):	Material Specification(用料标准):
✓ 01	COUNTER TOP 柜台面	16GA. THK. SUS 304 S/S
✓ 02	LEG 支腿	∅38mm 16 GA. THK. SUS 304 S/S TUBE
✓ 03	ADJUSTABLE FOOT INSERT 可调节嵌入式底脚	LUI CHUEN KEE (CHN)
✓ 04	REINFORCEMENT 加固件	16 GA. THK. SUS 304 S/S
05	SINK BOWL 洗碗槽	16 GA. THK. SUS 304 S/S
06	SINK WASTE 废料槽	
✓ 07	S.S. CROSS RAIL 横梁	∅32mm 16 GA. THK. SUS 304 S/S TUBE
08	WALL MOUNTED BRACKET 壁装托架	16 GA. THK. SUS 304 S/S
09	UNDER SHELF 底架	18 GA. THK. SUS 304 S/S
10	MIXING FAUCET 混合龙头	
11	OVER SHELF 顶架	18 GA. THK. SUS 304 S/S
12	OUTER DOOR PANEL 外板	20 GA. THK. SUS 304 S/S
13	INNER DOOR PANEL 内板	22 GA. THK. SUS 304 S/S
14	CABINET BODY 柜身	20 GA. THK. SUS 304 S/S
15	CORNER BUMPER 拐角防护套	COLSON (CHN)
16	SWIVEL CASTOR 旋转角轮	GLOBE (CHN)
17	SOUND DEADEN MATERIAL 隔音材料	3mm THICKNESS
18	WALL FLASHING 防水面	20 GA. THK. SUS 304 S/S
19	CONDENSING UNIT 制冷机组	DANFOSS (CHN)
20	NOZZLE 排气口	∅25mm SUS 304 S/S TUBE

No:	Item No(款号):	Qty(数量):	No:	Item No(款号):	Qty(数量):

Remark(备注):

 M5

SPOT WELDED A THREADED SHAFT TO THE UNDERSIDE OF WORK TOP / SHELF. THEN USE UNITS TO FIX WITH THE REINFORCEMENT / BRACKETS

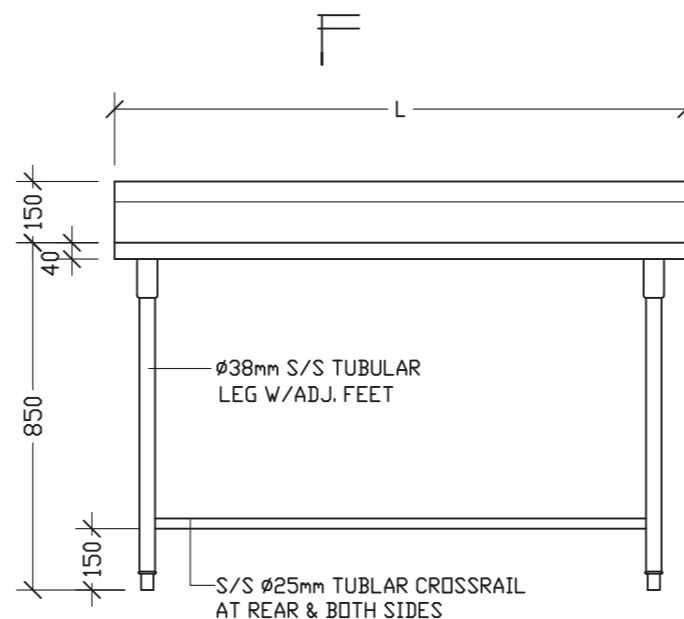

ELEVATION

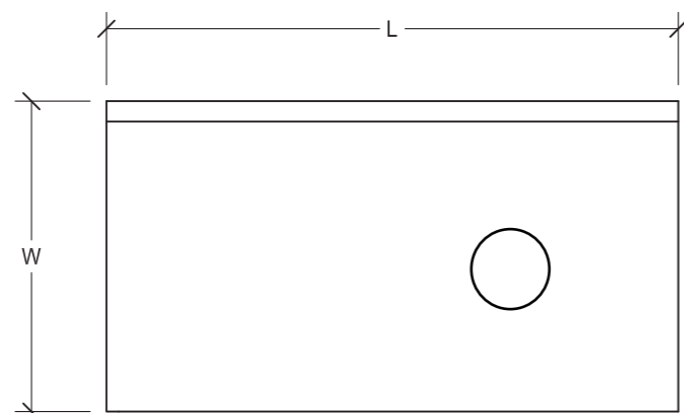

PLAN

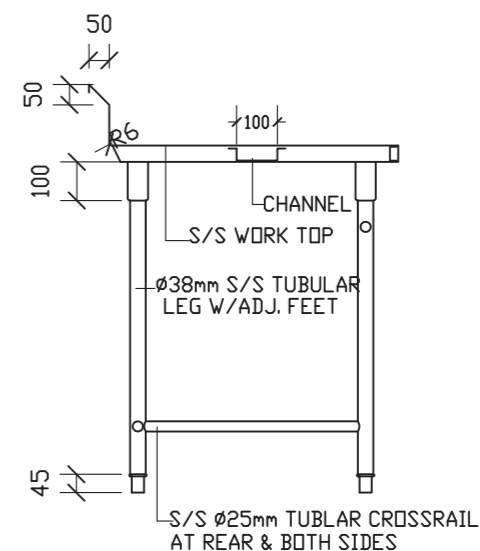

SECTION

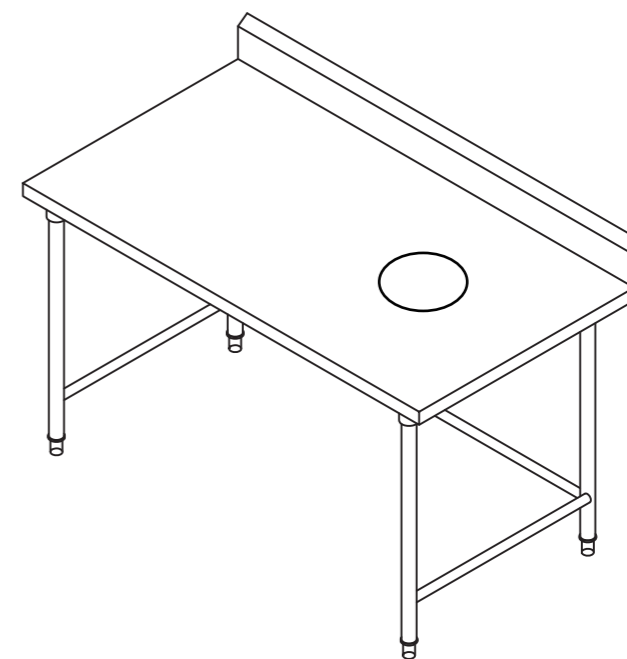

ISOMETRIC VIEW

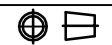
技术说明:				SKU:			
1.所有产品边缘不能有毛刺, 覆膜面不能刮花;				名称:	建德C40+潜水俱乐部厨房		
2.公差要求标准: 符合GB/T G3280-2015不锈钢冷轧钢板和钢带标准中PT.A的公称宽度要求;				材料:			
3.所有标注尺寸为外尺寸;				编制:		日期:	
4.未注膜面方向朝外。				审核:		日期:	
A						视角:	
版本		批准	日期			版本:	A

STAINLESS STEEL SHOP DRAWING (CUSTOM)

不锈钢件生产要求图

Product Description (产品说明):	Work Table W/Single Big Sinks
	工作台连大单星盆
Model Type (模具型号):	STBSH1 V03

No:	Parts(零部件):	Material Specification(用料标准):
✓ 01	COUNTER TOP 柜台面	16GA. THK. SUS 304 S/S
✓ 02	LEG 支腿	∅38mm 16 GA. THK. SUS 304 S/S TUBE
✓ 03	ADJUSTABLE FOOT INSERT 可调节嵌入式底脚	LUI CHUEN KEE (CHN)
✓ 04	REINFORCEMENT 加固件	16 GA. THK. SUS 304 S/S
✓ 05	SINK BOWL 洗碗槽	16 GA. THK. SUS 304 S/S
06	SINK WASTE 废料槽	
✓ 07	S.S. CROSS RAIL 横梁	∅32mm 16 GA. THK. SUS 304 S/S TUBE
08	WALL MOUNTED BRACKET 壁装托架	16 GA. THK. SUS 304 S/S
09	UNDER SHELF 底架	18 GA. THK. SUS 304 S/S
✓ 10	MIXING FAUCET 混合龙头	
11	OVER SHELF 顶架	18 GA. THK. SUS 304 S/S
12	OUTER DOOR PANEL 外板	20 GA. THK. SUS 304 S/S
13	INNER DOOR PANEL 内板	22 GA. THK. SUS 304 S/S
14	CABINET BODY 柜身	20 GA. THK. SUS 304 S/S
15	CORNER BUMPER 拐角防护套	COLSON (CHN)
16	SWIVEL CASTOR 旋转角轮	GLOBE (CHN)
17	SOUND DEADEN MATERIAL 隔音材料	3mm THICKNESS
18	WALL FLASHING 防水面	20 GA. THK. SUS 304 S/S
19	CONDENSING UNIT 制冷机组	DANFOSS (CHN)
20	NOZZLE 排气口	∅25mm SUS 304 S/S TUBE

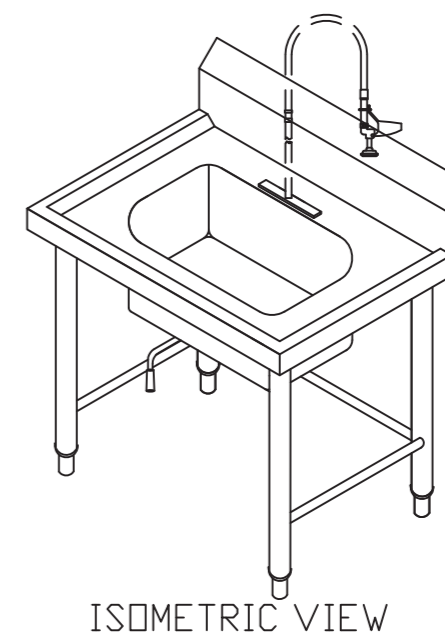
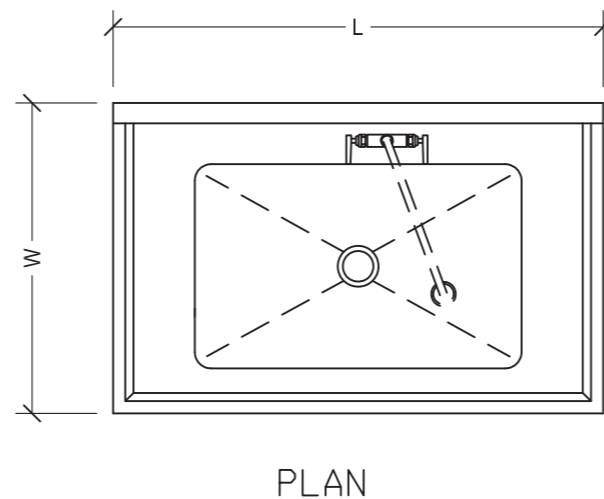
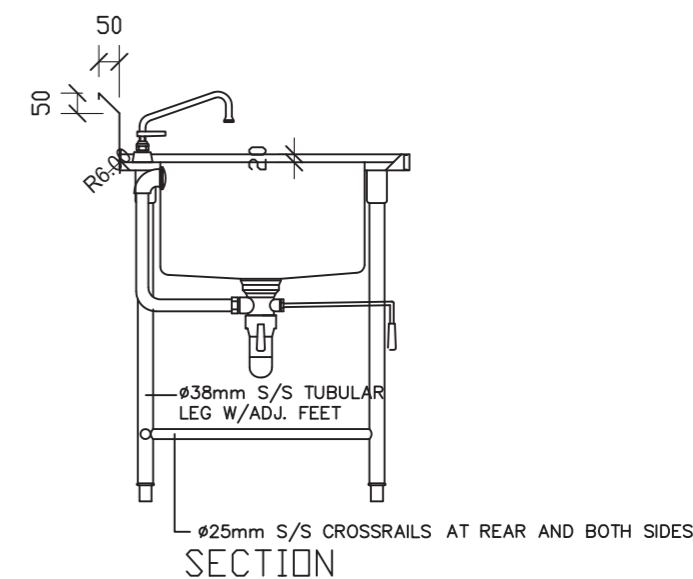
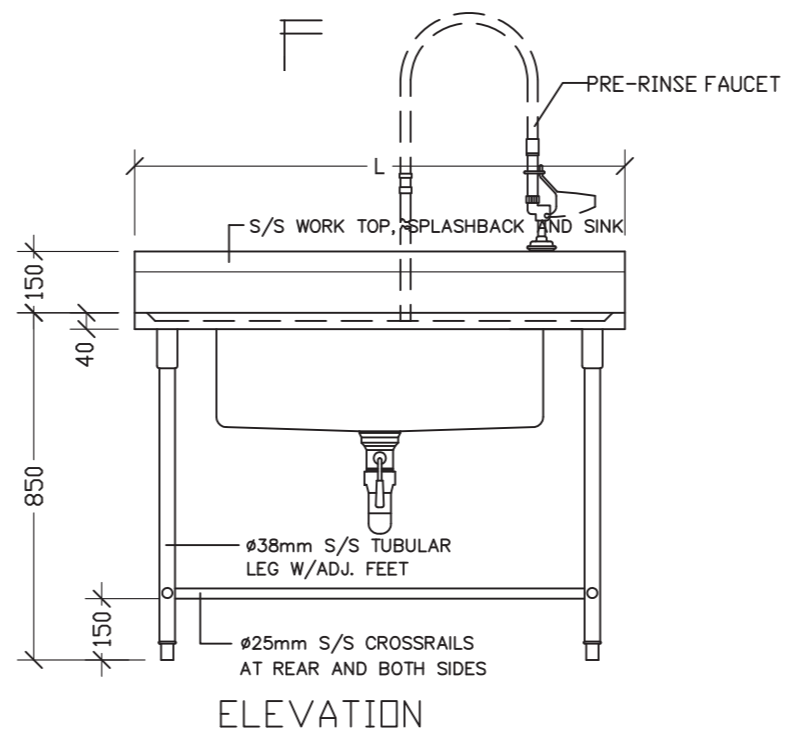

No:	Item No(款号):	Qty(数量):	No:	Item No(款号):	Qty(数量):

Remark(备注):



SPOT WELDED A THREADED SHAFT TO THE UNDERSIDE OF WORK TOP / SHELF. THEN USE UNITS TO FIX WITH THE REINFORCEMENT / BRACKETS

技术说明:				SKU:			
1.所有产品边缘不能有毛刺, 覆膜面不能刮花;				名称:	建德C40+潜水俱乐部厨房		
2.公差要求标准: 符合GB/T G3280-2015不锈钢冷轧钢板和钢带标准中PT.A的公称宽度要求;				材料:			
3.所有标注尺寸为外尺寸;				编制:		日期:	
4.未注膜面方向朝外。				审核:		日期:	
A						视角:	☉
版本			批准	日期		版本:	A

STAINLESS STEEL SHOP DRAWING (CUSTOM)

不锈钢件生产要求图

Product Description (产品说明):	Single Wall Mounted Shelving
	单层挂墙层架
Model Type (模具型号):	JBW1 V04

No:	Parts(零部件):	Material Specification(用料标准):
01	COUNTER TOP 柜台面	16GA. THK. SUS 304 S/S
02	LEG 支腿	∅38mm 16 GA. THK. SUS 304 S/S TUBE
03	ADJUSTABLE FOOT INSERT 可调节嵌入式底脚	LUI CHUEN KEE (CHN)
✓ 04	REINFORCEMENT 加固件	16 GA. THK. SUS 304 S/S
05	SINK BOWL 洗碗槽	16 GA. THK. SUS 304 S/S
06	SINK WASTE 废料槽	
07	S.S. CROSS RAIL 横梁	∅32mm 16 GA. THK. SUS 304 S/S TUBE
✓ 08	WALL MOUNTED BRACKET 壁装托架	16 GA. THK. SUS 304 S/S
09	UNDER SHELF 底架	18 GA. THK. SUS 304 S/S
10	MIXING FAUCET 混合龙头	
✓ 11	OVER SHELF 顶架	18 GA. THK. SUS 304 S/S
12	OUTER DOOR PANEL 外板	20 GA. THK. SUS 304 S/S
13	INNER DOOR PANEL 内板	22 GA. THK. SUS 304 S/S
14	CABINET BODY 柜身	20 GA. THK. SUS 304 S/S
15	CORNER BUMPER 拐角防护套	COLSON (CHN)
16	SWIVEL CASTOR 旋转角轮	GLOBE (CHN)
17	SOUND DEADEN MATERIAL 隔音材料	3mm THICKNESS
18	WALL FLASHING 防水面	20 GA. THK. SUS 304 S/S
19	CONDENSING UNIT 制冷机组	DANFOSS (CHN)
20	NOZZLE 排气口	∅25mm SUS 304 S/S TUBE

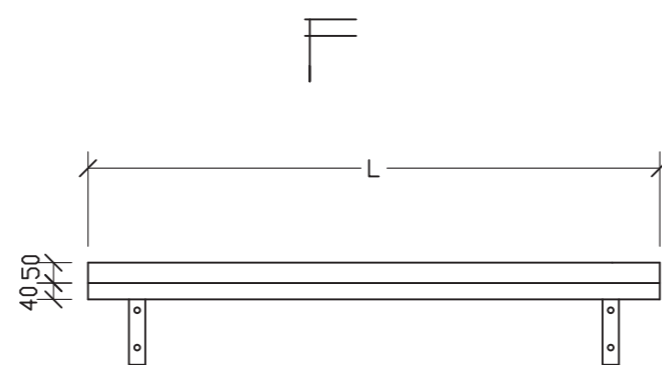

ELEVATION

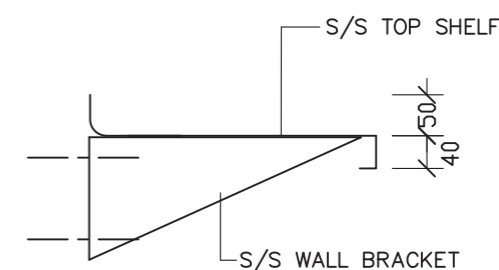

SECTION

No:	Item No(款号):	Qty(数量):	No:	Item No(款号):	Qty(数量):

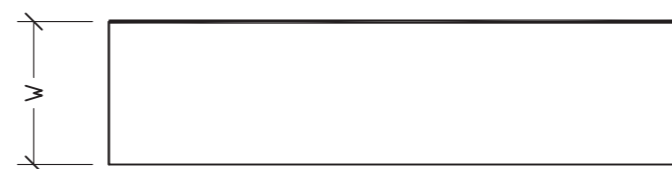

PLAN

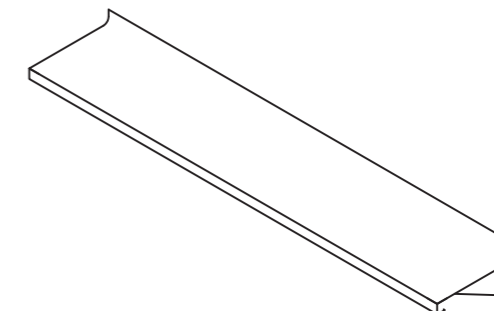

ISOMETRIC VIEW

Remark(备注):



SPOT WELDED A THREADED SHAFT TO THE UNDERSIDE OF WORK TOP / SHELF. THEN USE UNITS TO FIX WITH THE REINFORCEMENT / BRACKETS

技术说明:				SKU:			
1.所有产品边缘不能有毛刺, 覆膜面不能刮花;				名称:	建德C40+潜水俱乐部厨房		
2.公差要求标准: 符合GB/T G3280-2015不锈钢冷轧钢板和钢带标准中PT.A的公称宽度要求;				材料:			
3.所有标注尺寸为外尺寸;				编制:		日期:	
4.未注膜面方向朝外。				审核:		日期:	
A						视角:	☉
版本		批准	日期			版本:	A

STAINLESS STEEL SHOP DRAWING (CUSTOM)

不锈钢件生产要求图

Product Description (产品说明):	Exhaust Canopy
	集气罩
Model Type (模具型号):	EHSA V05

No:	Parts(零部件):	Material Specification(用料标准):
01	COUNTER TOP 柜台面	16GA. THK. SUS 304 S/S
02	LEG 支腿	∅38mm 16 GA. THK. SUS 304 S/S TUBE
03	ADJUSTABLE FOOT INSERT 可调节嵌入式底脚	LUI CHUEN KEE (CHN)
✓ 04	REINFORCEMENT 加固件	16 GA. THK. SUS 304 S/S
05	SINK BOWL 洗碗槽	16 GA. THK. SUS 304 S/S
06	SINK WASTE 废料槽	
07	S.S. CROSS RAIL 横梁	∅32mm 16 GA. THK. SUS 304 S/S TUBE
08	WALL MOUNTED BRACKET 壁装托架	16 GA. THK. SUS 304 S/S
09	UNDER SHELF 底架	18 GA. THK. SUS 304 S/S
10	MIXING FAUCET 混合龙头	
11	OVER SHELF 顶架	18 GA. THK. SUS 304 S/S
12	OUTER DOOR PANEL 外板	20 GA. THK. SUS 304 S/S
✓ 13	INNER DOOR PANEL 内板	22 GA. THK. SUS 304 S/S
✓ 14	CABINET BODY 柜身	20 GA. THK. SUS 304 S/S
15	CORNER BUMPER 拐角防护套	COLSON (CHN)
16	SWIVEL CASTOR 旋转角轮	GLOBE (CHN)
17	SOUND DEADEN MATERIAL 隔音材料	3mm THICKNESS
18	WALL FLASHING 防水面	20 GA. THK. SUS 304 S/S
19	CONDENSING UNIT 制冷机组	DANFOSS (CHN)
20	NOZZLE 排气口	∅25mm SUS 304 S/S TUBE

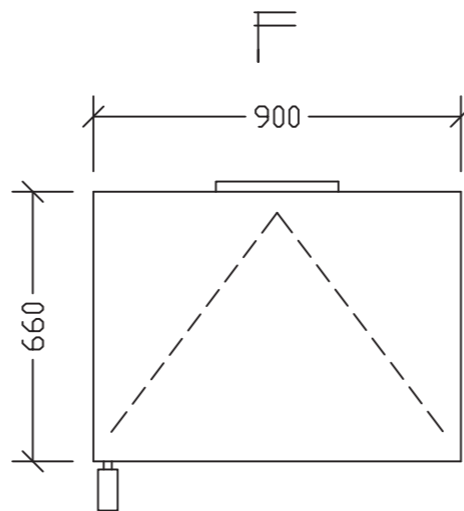

ELEVATION
(主视图)

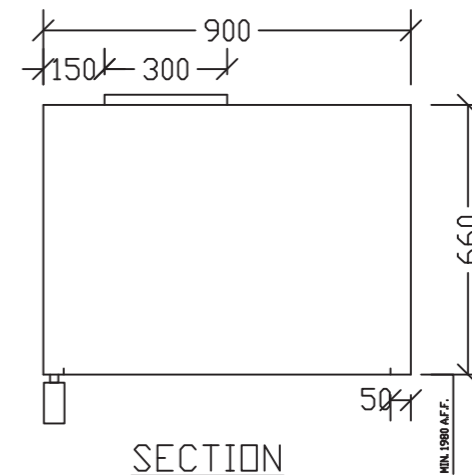

SECTION
(侧视图)

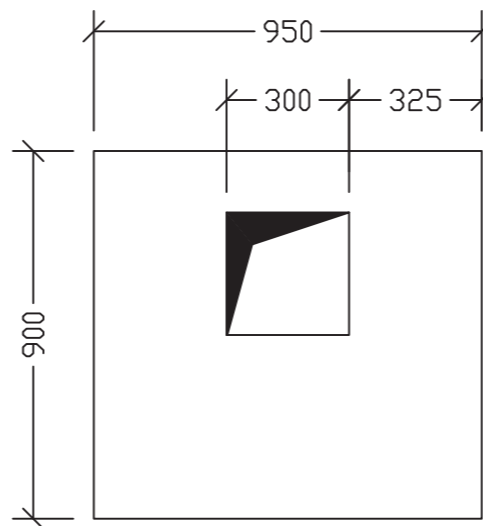

PLAN
(俯视图)

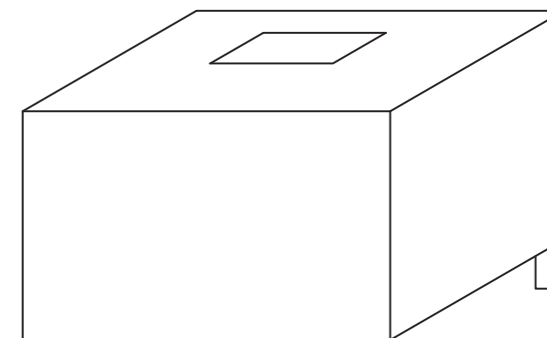

ISOMETRIC VIEW
(轴侧图)

No:	Item No(款号):	Qty(数量):	No:	Item No(款号):	Qty(数量):

Remark(备注):



SPOT WELDED A THREADED SHAFT TO THE UNDERSIDE OF WORK TOP / SHELF. THEN USE UNITS TO FIX WITH THE REINFORCEMENT / BRACKETS

技术说明:
 1.所有产品边缘不能有毛刺, 覆膜面不能刮花;
 2.公差要求标准: 符合GB/T G3280-2015不锈钢冷轧钢板和钢带标准中PT.A的公称宽度要求;
 3.所有标注尺寸为外尺寸;
 4.未注膜面方向朝外。

SKU:
 名称: 建德C40+潜水俱乐部厨房
 材料:
 编制:
 审核:

日期:
 日期:
 视角:
 版本: A

STAINLESS STEEL SHOP DRAWING (CUSTOM)

不锈钢件生产要求图

Product Description (产品说明):	Mobile Working Table W/Double Under Shelf
	活动工作台连二下层板
Model Type (模具型号):	TS2-M V07

No:	Parts(零部件):	Material Specfication(用料标准):
✓ 01	COUNTER TOP 柜台面	16GA. THK. SUS 304 S/S
✓ 02	LEG 支腿	∅38mm 16 GA. THK. SUS 304 S/S TUBE
03	ADJUSTABLE FOOT INSERT 可调节嵌入式底脚	LUI CHUEN KEE (CHN)
✓ 04	REINFORCEMENT 加固件	16 GA. THK. SUS 304 S/S
05	SINK BOWL 洗碗槽	16 GA. THK. SUS 304 S/S
06	SINK WASTE 废料槽	
07	S.S. CROSS RAIL 横梁	∅32mm 16 GA. THK. SUS 304 S/S TUBE
08	WALL MOUNTED BRACKET 壁装托架	16 GA. THK. SUS 304 S/S
✓ 09	UNDER SHELF 底架	18 GA. THK. SUS 304 S/S
10	MIXING FAUCET 混合龙头	
11	OVER SHELF 顶架	18 GA. THK. SUS 304 S/S
12	OUTER DOOR PANEL 外板	20 GA. THK. SUS 304 S/S
13	INNER DOOR PANEL 内板	22 GA. THK. SUS 304 S/S
14	CABINET BODY 柜身	20 GA. THK. SUS 304 S/S
15	CORNER BUMPER 拐角防护套	COLSON (CHN)
✓ 16	SWIVEL CASTOR 旋转角轮	GLOBE (CHN)
17	SOUND DEADEN MATERIAL 隔音材料	3mm THICKNESS
18	WALL FLASHING 防水面	20 GA. THK. SUS 304 S/S
19	CONDENSING UNIT 制冷机组	DANFOSS (CHN)
20	NOZZLE 排气口	∅25mm SUS 304 S/S TUBE

No:	Item No(款号):	Qty(数量):	No:	Item No(款号):	Qty(数量):

Remark(备注):

 M5

SPOT WELDED A THREADED SHAFT TO THE UNDERSIDE OF WORK TOP / SHELF. THEN USE UNITS TO FIX WITH THE REINFORCEMENT / BRACKETS

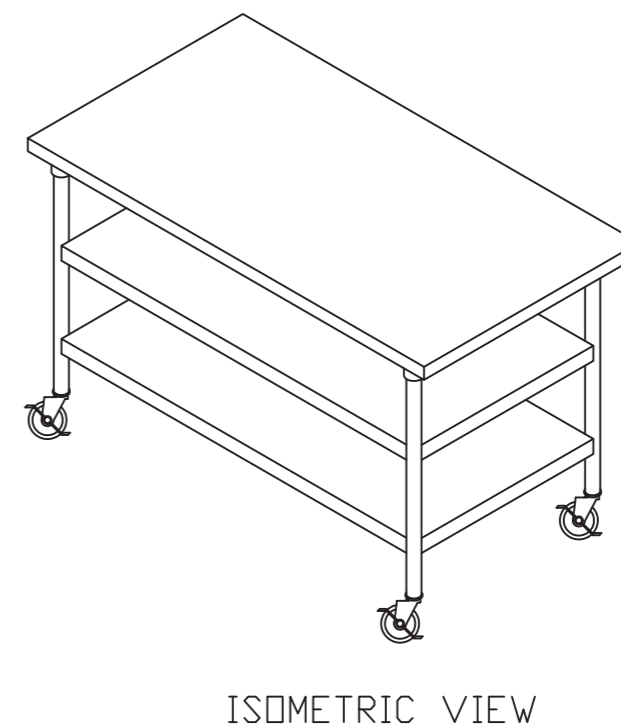
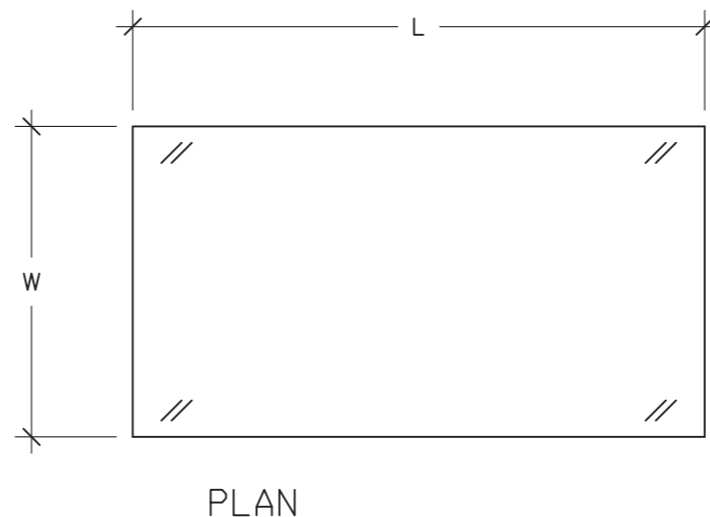
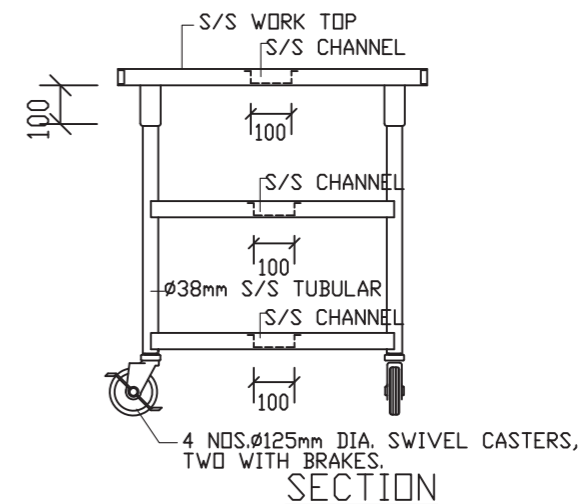
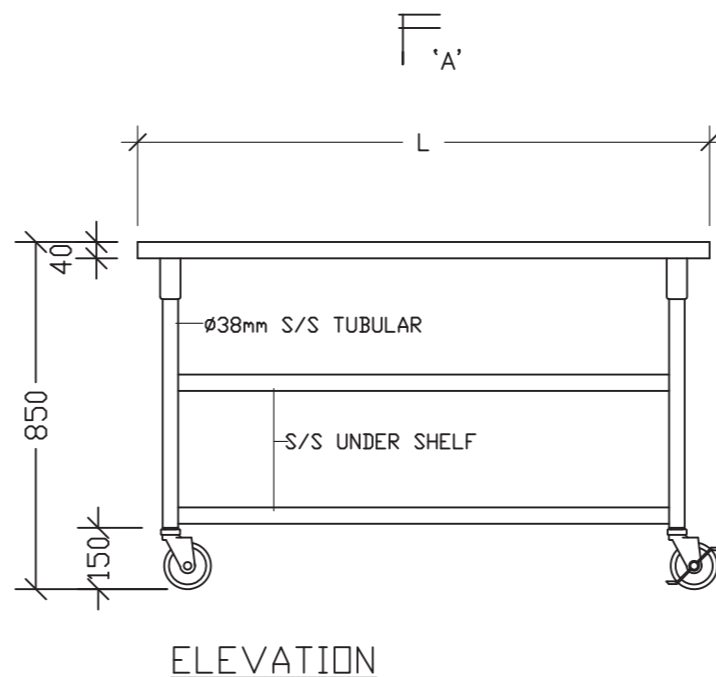

技术说明:				SKU:			
1.所有产品边缘不能有毛刺, 覆膜面不能刮花;				名称:	建德C40+潜水俱乐部厨房		
2.公差要求标准: 符合GB/T G3280-2015不锈钢冷轧钢板和钢带标准中PT.A的公称宽度要求;				材料:			
3.所有标注尺寸为外尺寸;				编制:		日期:	
4.未注膜面方向朝外。				审核:		日期:	
A						视角:	
版本		批准	日期			版本:	A

STAINLESS STEEL SHOP DRAWING (CUSTOM)

不锈钢件生产要求图

Product Description (产品说明):	Work Table W/Twin Sinks
	工作台连双星盆 (中间去水)
Model Type (模具型号):	STSH2 V08

No:	Parts(零部件):	Material Specification(用料标准):
✓ 01	COUNTER TOP 柜台面	16GA. THK. SUS 304 S/S
✓ 02	LEG 支腿	∅38mm 16 GA. THK. SUS 304 S/S TUBE
✓ 03	ADJUSTABLE FOOT INSERT 可调节嵌入式底脚	LUI CHUEN KEE (CHN)
✓ 04	REINFORCEMENT 加固件	16 GA. THK. SUS 304 S/S
✓ 05	SINK BOWL 洗碗槽	16 GA. THK. SUS 304 S/S
06	SINK WASTE 废料槽	
✓ 07	S.S. CROSS RAIL 横梁	∅32mm 16 GA. THK. SUS 304 S/S TUBE
08	WALL MOUNTED BRACKET 壁装托架	16 GA. THK. SUS 304 S/S
09	UNDER SHELF 底架	18 GA. THK. SUS 304 S/S
✓ 10	MIXING FAUCET 混合龙头	
11	OVER SHELF 顶架	18 GA. THK. SUS 304 S/S
12	OUTER DOOR PANEL 外板	20 GA. THK. SUS 304 S/S
13	INNER DOOR PANEL 内板	22 GA. THK. SUS 304 S/S
14	CABINET BODY 柜身	20 GA. THK. SUS 304 S/S
15	CORNER BUMPER 拐角防护套	COLSON (CHN)
16	SWIVEL CASTOR 旋转角轮	GLOBE (CHN)
17	SOUND DEADEN MATERIAL 隔音材料	3mm THICKNESS
18	WALL FLASHING 防水面	20 GA. THK. SUS 304 S/S
19	CONDENSING UNIT 制冷机组	DANFOSS (CHN)
20	NOZZLE 排气口	∅25mm SUS 304 S/S TUBE

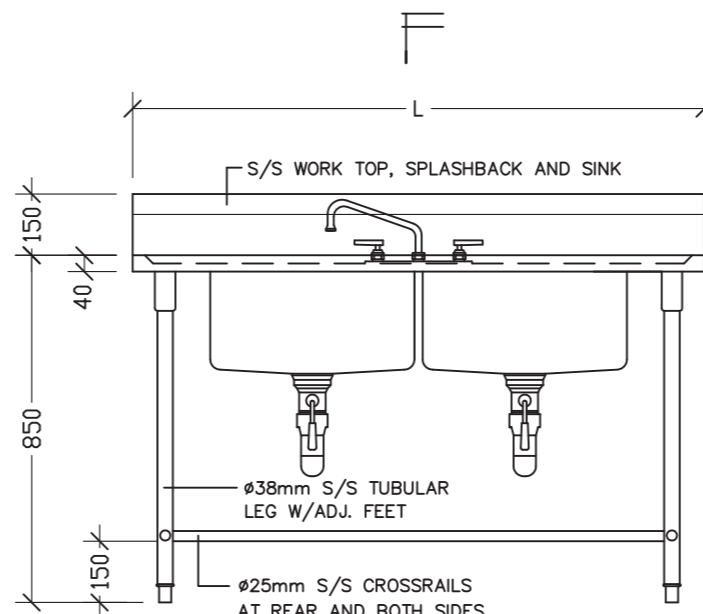

ELEVATION

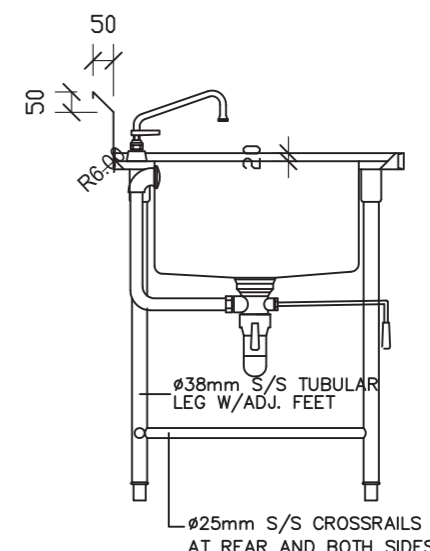

SECTION

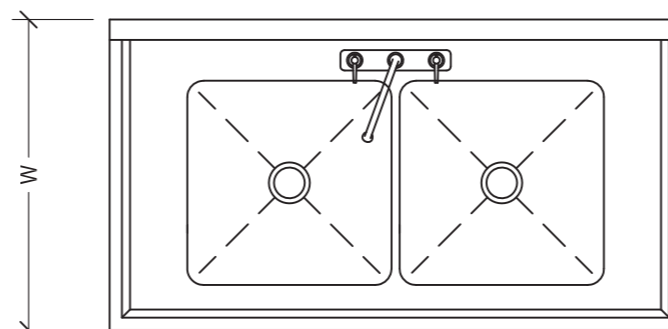

PLAN

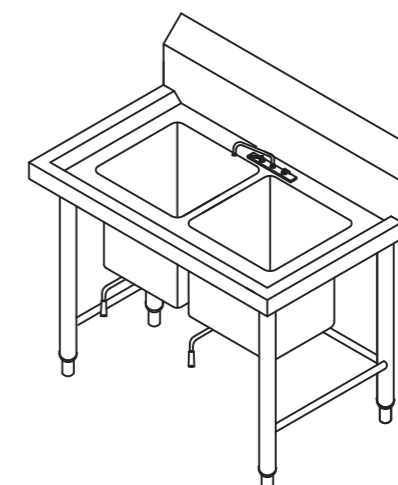

ISOMETRIC VIEW

No:	Item No(款号):	Qty(数量):	No:	Item No(款号):	Qty(数量):

Remark(备注):



SPOT WELDED A THREADED SHAFT TO THE UNDERSIDE OF WORK TOP / SHELF. THEN USE UNITS TO FIX WITH THE REINFORCEMENT / BRACKETS

技术说明:				SKU:			
1.所有产品边缘不能有毛刺, 覆膜面不能刮花;				名称:	建德C40+潜水俱乐部厨房		
2.公差要求标准: 符合GB/T G3280-2015不锈钢冷轧钢板和钢带标准中PT.A的公称宽度要求;				材料:			
3.所有标注尺寸为外尺寸;				编制:		日期:	
4.未注膜面方向朝外。				审核:		日期:	
A						视角:	☉
版本		批准	日期			版本:	A

STAINLESS STEEL SHOP DRAWING (CUSTOM)

不锈钢件生产要求图

Product Description (产品说明):	Single Wall Mounted Shelving
	单层挂墙层架
Model Type (模具型号):	JBW1 V09

No:	Parts(零部件):	Material Specification(用料标准):
01	COUNTER TOP 柜台面	16GA. THK. SUS 304 S/S
02	LEG 支腿	∅38mm 16 GA. THK. SUS 304 S/S TUBE
03	ADJUSTABLE FOOT INSERT 可调节嵌入式底脚	LUI CHUEN KEE (CHN)
✓ 04	REINFORCEMENT 加固件	16 GA. THK. SUS 304 S/S
05	SINK BOWL 洗碗槽	16 GA. THK. SUS 304 S/S
06	SINK WASTE 废料槽	
07	S.S. CROSS RAIL 横梁	∅32mm 16 GA. THK. SUS 304 S/S TUBE
✓ 08	WALL MOUNTED BRACKET 壁装托架	16 GA. THK. SUS 304 S/S
09	UNDER SHELF 底架	18 GA. THK. SUS 304 S/S
10	MIXING FAUCET 混合龙头	
✓ 11	OVER SHELF 顶架	18 GA. THK. SUS 304 S/S
12	OUTER DOOR PANEL 外板	20 GA. THK. SUS 304 S/S
13	INNER DOOR PANEL 内板	22 GA. THK. SUS 304 S/S
14	CABINET BODY 柜身	20 GA. THK. SUS 304 S/S
15	CORNER BUMPER 拐角防护套	COLSON (CHN)
16	SWIVEL CASTOR 旋转角轮	GLOBE (CHN)
17	SOUND DEADEN MATERIAL 隔音材料	3mm THICKNESS
18	WALL FLASHING 防水面	20 GA. THK. SUS 304 S/S
19	CONDENSING UNIT 制冷机组	DANFOSS (CHN)
20	NOZZLE 排气口	∅25mm SUS 304 S/S TUBE

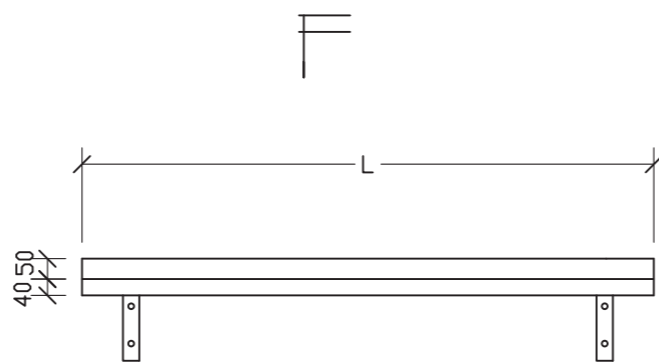

ELEVATION

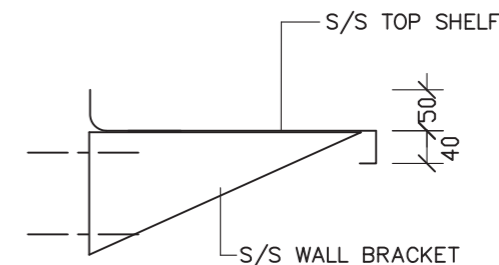

SECTION

No:	Item No(款号):	Qty(数量):	No:	Item No(款号):	Qty(数量):

Remark(备注):



SPOT WELDED A THREADED SHAFT TO THE UNDERSIDE OF WORK TOP / SHELF. THEN USE UNITS TO FIX WITH THE REINFORCEMENT / BRACKETS

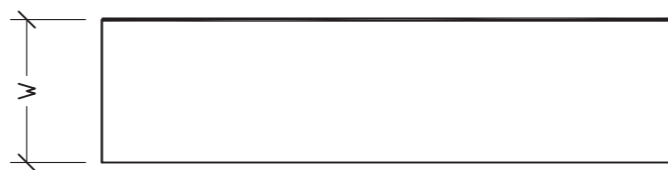

PLAN

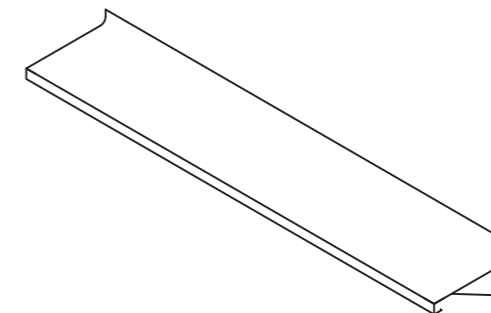

ISOMETRIC VIEW

技术说明:				SKU:			
1.所有产品边缘不能有毛刺, 覆膜面不能刮花;				名称:	建德C40+潜水俱乐部厨房		
2.公差要求标准: 符合GB/T G3280-2015不锈钢冷轧钢板和钢带标准中PT.A的公称宽度要求;				材料:			
3.所有标注尺寸为外尺寸;				编制:		日期:	
4.未注膜面方向朝外。				审核:		日期:	
A						视角:	☉
版本		批准	日期			版本:	A

STAINLESS STEEL SHOP DRAWING (CUSTOM)

不锈钢件生产要求图

Product Description (产品说明):	Uright Storage Cabinet
	高身储物柜
Model Type (模具型号):	CUS V10

No:	Parts(零部件):	Material Specfication(用料标准):
✓ 01	COUNTER TOP 柜台面	16GA. THK. SUS 304 S/S
02	LEG 支腿	∅38mm 16 GA. THK. SUS 304 S/S TUBE
✓ 03	ADJUSTABLE FOOT INSERT 可调节嵌入式底脚	LUI CHUEN KEE (CHN)
✓ 04	REINFORCEMENT 加固件	16 GA. THK. SUS 304 S/S
05	SINK BOWL 洗碗槽	16 GA. THK. SUS 304 S/S
06	SINK WASTE 废料槽	
07	S.S. CROSS RAIL 横梁	∅32mm 16 GA. THK. SUS 304 S/S TUBE
08	WALL MOUNTED BRACKET 壁装托架	16 GA. THK. SUS 304 S/S
✓ 09	UNDER SHELF 底架	18 GA. THK. SUS 304 S/S
10	MIXING FAUCET 混合龙头	
11	OVER SHELF 顶架	18 GA. THK. SUS 304 S/S
✓ 12	OUTER DOOR PANEL 外板	20 GA. THK. SUS 304 S/S
✓ 13	INNER DOOR PANEL 内板	22 GA. THK. SUS 304 S/S
✓ 14	CABINET BODY 柜身	20 GA. THK. SUS 304 S/S
15	CORNER BUMPER 拐角防护套	COLSON (CHN)
16	SWIVEL CASTOR 旋转角轮	GLOBE (CHN)
17	SOUND DEADEN MATERIAL 隔音材料	3mm THICKNESS
18	WALL FLASHING 防水面	20 GA. THK. SUS 304 S/S
19	CONDENSING UNIT 制冷机组	DANFOSS (CHN)
20	NOZZLE 排气口	∅25mm SUS 304 S/S TUBE

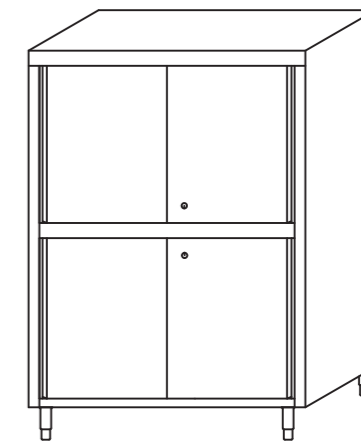
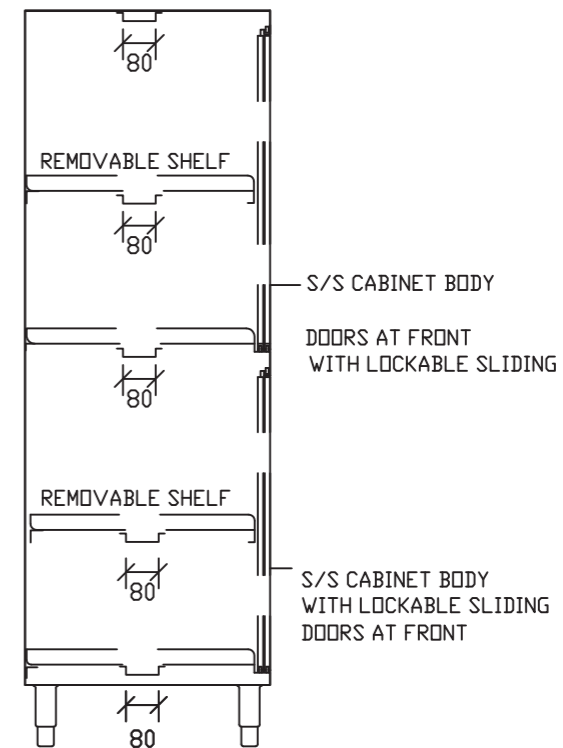
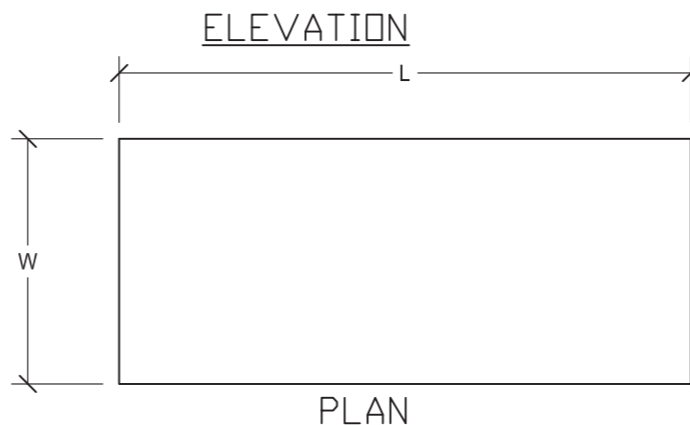
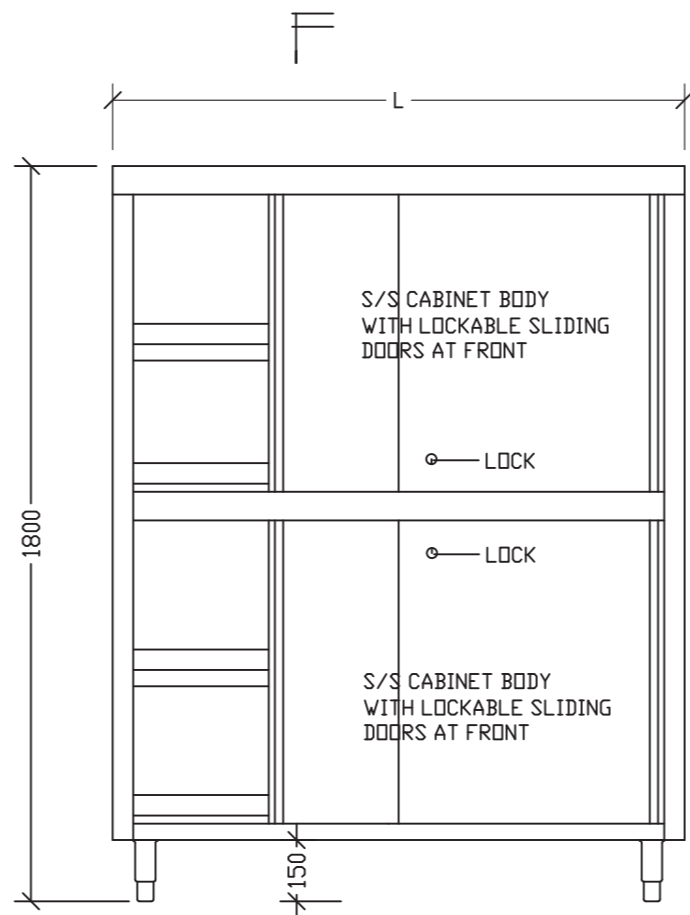

No:	Item No(款号):	Qty(数量):	No:	Item No(款号):	Qty(数量):

Remark(备注):



SPOT WELDED A THREADED SHAFT TO THE UNDERSIDE OF WORK TOP / SHELF. THEN USE UNITS TO FIX WITH THE REINFORCEMENT / BRACKETS

技术说明:
 1.所有产品边缘不能有毛刺, 覆膜面不能刮花;
 2.公差要求标准: 符合GB/T G3280-2015不锈钢冷轧钢板和钢带标准中PT.A的公称宽度要求;
 3.所有标注尺寸为外尺寸;
 4.未注膜面方向朝外。

SKU:
 名称: 建德C40+潜水俱乐部厨房
 材料:
 编制:
 审核:

日期:
 日期:
 视角:
 版本: A

A	版本	批准	日期
---	----	----	----

STAINLESS STEEL SHOP DRAWING (CUSTOM)

不锈钢件生产要求图

Product Description (产品说明):	Work Cabinet
	工作掩门柜
Model Type (模具型号):	CBH X01

No:	Parts(零部件):	Material Specification(用料标准):
✓ 01	COUNTER TOP 柜台面	16GA. THK. SUS 304 S/S
02	LEG 支腿	Ø38mm 16 GA. THK. SUS 304 S/S TUBE
✓ 03	ADJUSTABLE FOOT INSERT 可调节嵌入式底脚	LUI CHUEN KEE (CHN)
✓ 04	REINFORCEMENT 加固件	16 GA. THK. SUS 304 S/S
05	SINK BOWL 洗碗槽	16 GA. THK. SUS 304 S/S
06	SINK WASTE 废料槽	
07	S.S. CROSS RAIL 横梁	Ø32mm 16 GA. THK. SUS 304 S/S TUBE
08	WALL MOUNTED BRACKET 壁装托架	16 GA. THK. SUS 304 S/S
✓ 09	UNDER SHELF 底架	18 GA. THK. SUS 304 S/S
10	MIXING FAUCET 混合龙头	
11	OVER SHELF 顶架	18 GA. THK. SUS 304 S/S
✓ 12	OUTER DOOR PANEL 外板	20 GA. THK. SUS 304 S/S
✓ 13	INNER DOOR PANEL 内板	22 GA. THK. SUS 304 S/S
✓ 14	CABINET BODY 柜身	20 GA. THK. SUS 304 S/S
15	CORNER BUMPER 拐角防护套	COLSON (CHN)
16	SWIVEL CASTOR 旋转角轮	GLOBE (CHN)
17	SOUND DEADEN MATERIAL 隔音材料	3mm THICKNESS
18	WALL FLASHING 防水面	20 GA. THK. SUS 304 S/S
19	CONDENSING UNIT 制冷机组	DANFOSS (CHN)
20	NOZZLE 排气口	Ø25mm SUS 304 S/S TUBE

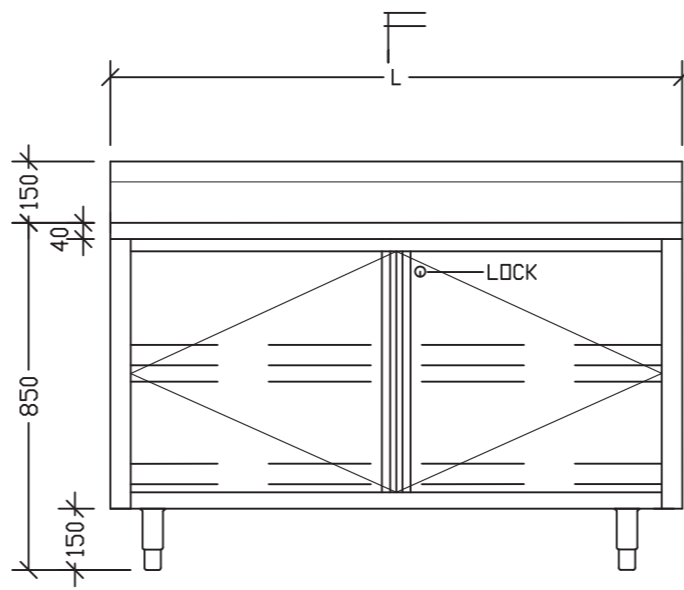

ELEVATION

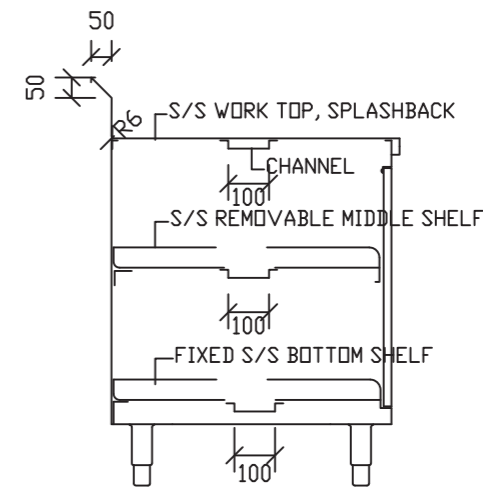

SECTION

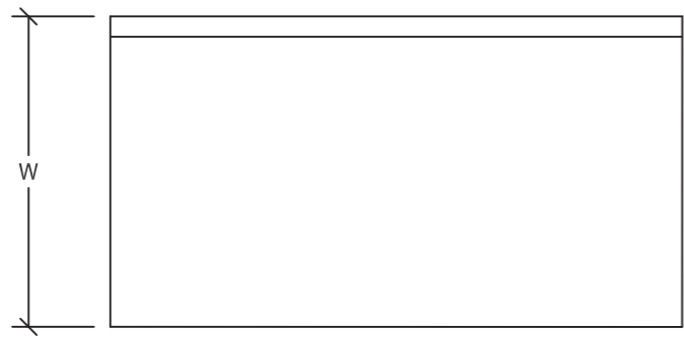

PLAN

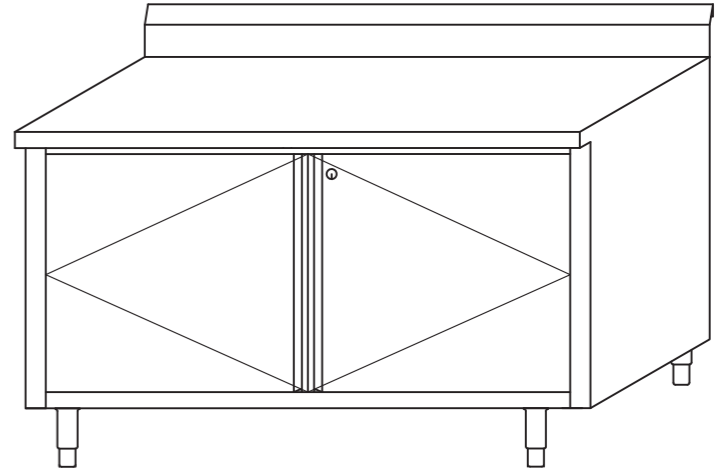

ISOMETRIC VIEW

No:	Item No(款号):	Qty(数量):	No:	Item No(款号):	Qty(数量):

Remark(备注):

M5	SPOT WELDED A THREADED SHAFT TO THE UNDERSIDE OF WORK TOP / SHELF. THEN USE UNITS TO FIX WITH THE REINFORCEMENT / BRACKETS
----	--

技术说明:				SKU:			
1.所有产品边缘不能有毛刺, 覆膜面不能刮花;				名称:	建德C40+潜水俱乐部厨房		
2.公差要求标准: 符合GB/T G3280-2015不锈钢冷轧钢板和钢带标准中PT.A的公称宽度要求;				材料:			
3.所有标注尺寸为外尺寸;				编制:		日期:	
4.未注膜面方向朝外。				审核:		日期:	
A						视角:	
版本			批准	日期		版本:	A

STAINLESS STEEL SHOP DRAWING (CUSTOM)

不锈钢件生产要求图

Product Description (产品说明):	Work Table W/Under Shelf
	工作台下置层板
Model Type (模具型号):	TBS1 X04

No:	Parts(零部件):	Material Specification(用料标准):
✓ 01	COUNTER TOP 柜台面	16GA. THK. SUS 304 S/S
✓ 02	LEG 支腿	∅38mm 16 GA. THK. SUS 304 S/S TUBE
✓ 03	ADJUSTABLE FOOT INSERT 可调节嵌入式底脚	LUI CHUEN KEE (CHN)
✓ 04	REINFORCEMENT 加固件	16 GA. THK. SUS 304 S/S
05	SINK BOWL 洗碗槽	16 GA. THK. SUS 304 S/S
06	SINK WASTE 废料槽	
✓ 07	S.S. CROSS RAIL 横梁	∅32mm 16 GA. THK. SUS 304 S/S TUBE
08	WALL MOUNTED BRACKET 壁装托架	16 GA. THK. SUS 304 S/S
09	UNDER SHELF 底架	18 GA. THK. SUS 304 S/S
10	MIXING FAUCET 混合龙头	
11	OVER SHELF 顶架	18 GA. THK. SUS 304 S/S
12	OUTER DOOR PANEL 外板	20 GA. THK. SUS 304 S/S
13	INNER DOOR PANEL 内板	22 GA. THK. SUS 304 S/S
14	CABINET BODY 柜身	20 GA. THK. SUS 304 S/S
15	CORNER BUMPER 拐角防护套	COLSON (CHN)
16	SWIVEL CASTOR 旋转角轮	GLOBE (CHN)
17	SOUND DEADEN MATERIAL 隔音材料	3mm THICKNESS
18	WALL FLASHING 防水面	20 GA. THK. SUS 304 S/S
19	CONDENSING UNIT 制冷机组	DANFOSS (CHN)
20	NOZZLE 排气口	∅25mm SUS 304 S/S TUBE

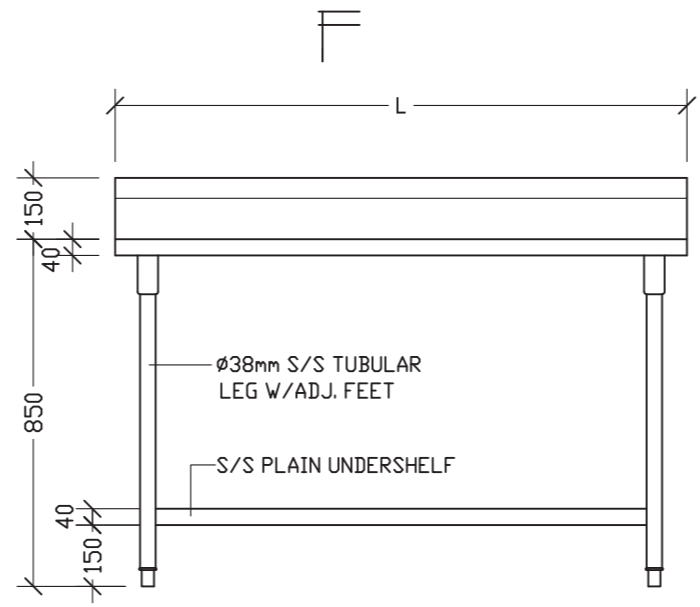

ELEVATION

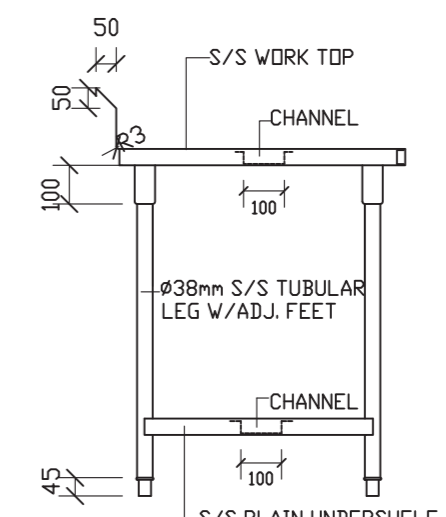

SECTION

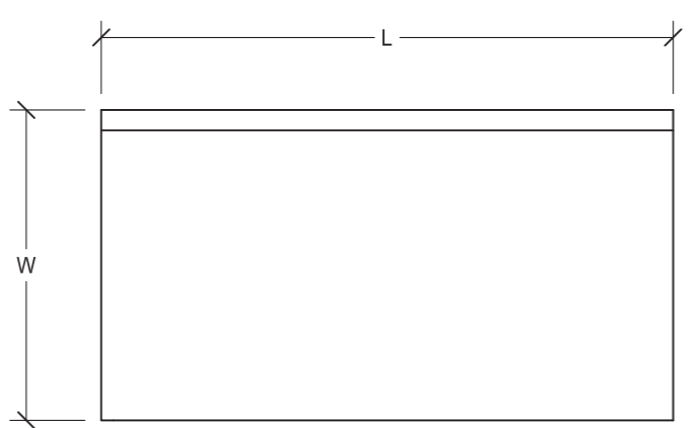

PLAN

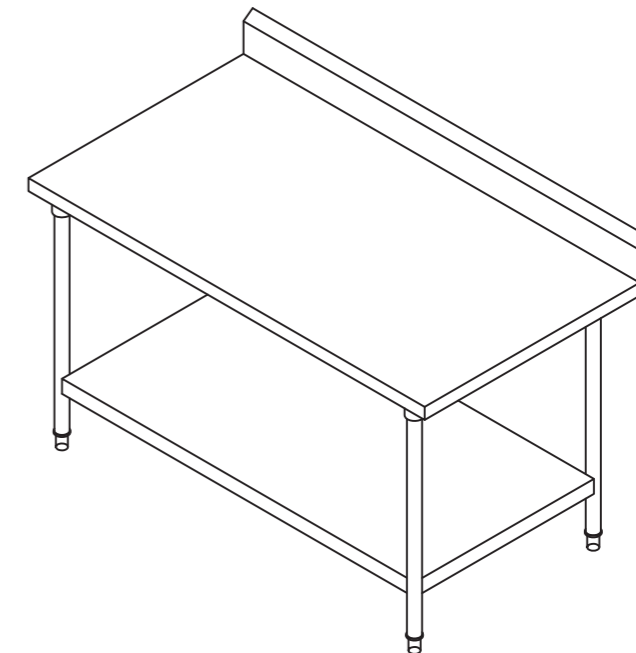

ISOMETRIC VIEW

No:	Item No(款号):	Qty(数量):	No:	Item No(款号):	Qty(数量):

Remark(备注):

 M5

SPOT WELDED A THREADED SHAFT TO THE UNDERSIDE OF WORK TOP / SHELF. THEN USE UNITS TO FIX WITH THE REINFORCEMENT / BRACKETS

技术说明:				SKU:			
1.所有产品边缘不能有毛刺, 覆膜面不能刮花;				名称:	建德C40+潜水俱乐部厨房		
2.公差要求标准: 符合GB/T G3280-2015不锈钢冷轧钢板和钢带标准中PT.A的公称宽度要求;				材料:			
3.所有标注尺寸为外尺寸;				编制:		日期:	
4.未注膜面方向朝外。				审核:		日期:	
A						视角:	
版本			批准	日期		版本:	A

STAINLESS STEEL SHOP DRAWING (CUSTOM)

不锈钢件生产要求图

Product Description (产品说明):	Cocktail Station W/Sink
	鸡尾酒台连星盆
Model Type (模具型号):	TCOC-S X05

No:	Parts(零部件):	Material Specfication(用料标准):
✓ 01	COUNTER TOP 柜台面	16GA. THK. SUS 304 S/S
✓ 02	LEG 支腿	∅38mm 16 GA. THK. SUS 304 S/S TUBE
✓ 03	ADJUSTABLE FOOT INSERT 可调节嵌入式底脚	LUI CHUEN KEE (CHN)
✓ 04	REINFORCEMENT 加固件	16 GA. THK. SUS 304 S/S
✓ 05	SINK BOWL 洗碗槽	16 GA. THK. SUS 304 S/S
06	SINK WASTE 废料槽	
✓ 07	S.S. CROSS RAIL 横梁	∅32mm 16 GA. THK. SUS 304 S/S TUBE
08	WALL MOUNTED BRACKET 壁装托架	16 GA. THK. SUS 304 S/S
09	UNDER SHELF 底架	18 GA. THK. SUS 304 S/S
✓ 10	MIXING FAUCET 混合龙头	
11	OVER SHELF 顶架	18 GA. THK. SUS 304 S/S
12	OUTER DOOR PANEL 外板	20 GA. THK. SUS 304 S/S
13	INNER DOOR PANEL 内板	22 GA. THK. SUS 304 S/S
✓ 14	CABINET BODY 柜身	20 GA. THK. SUS 304 S/S
15	CORNER BUMPER 拐角防护套	COLSON (CHN)
16	SWIVEL CASTOR 旋转角轮	GLOBE (CHN)
17	SOUND DEADEN MATERIAL 隔音材料	3mm THICKNESS
18	WALL FLASHING 防水面	20 GA. THK. SUS 304 S/S
19	CONDENSING UNIT 制冷机组	DANFOSS (CHN)
✓ 20	NOZZLE 排气口	∅25mm SUS 304 S/S TUBE

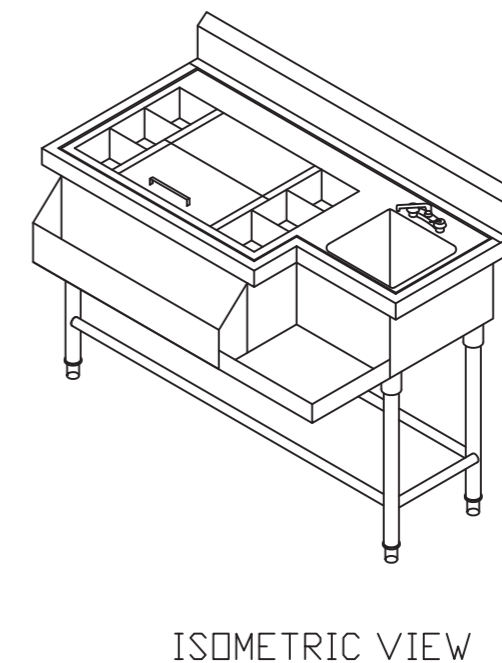
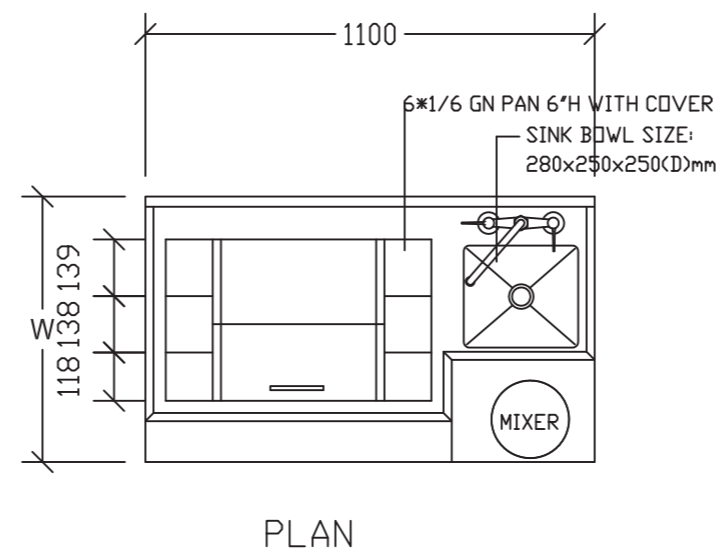
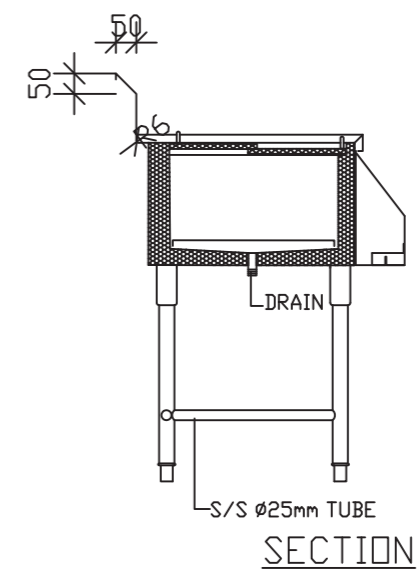
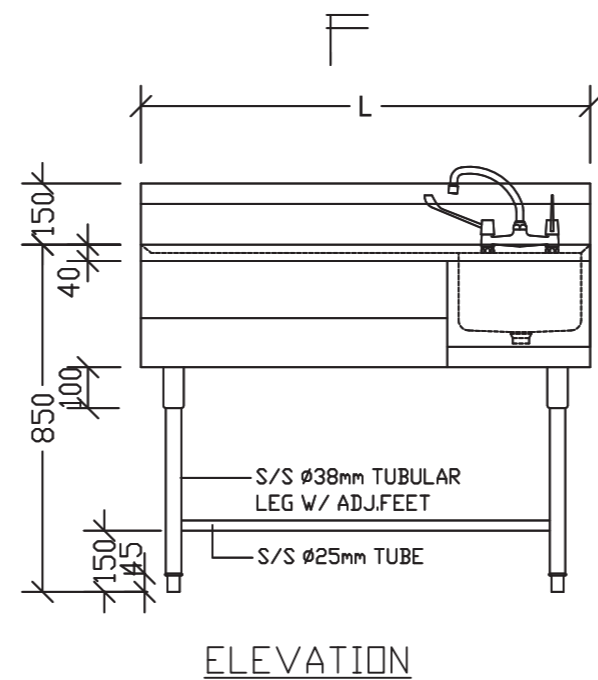

No:	Item No(款号):	Qty(数量):	No:	Item No(款号):	Qty(数量):

Remark(备注):

M5 SPOT WELDED A THREADED SHAFT TO THE UNDERSIDE OF WORK TOP / SHELF. THEN USE UNITS TO FIX WITH THE REINFORCEMENT / BRACKETS

技术说明:				SKU:			
1.所有产品边缘不能有毛刺, 覆膜面不能刮花;				名称:	建德C40+潜水俱乐部厨房		
2.公差要求标准: 符合GB/T G3280-2015不锈钢冷轧钢板和钢带标准中PT.A的公称宽度要求;				材料:			
3.所有标注尺寸为外尺寸;				编制:		日期:	
4.未注膜面方向朝外。				审核:		日期:	
A						视角:	
版本		批准	日期			版本:	A

STAINLESS STEEL SHOP DRAWING (CUSTOM)

不锈钢件生产要求图

Product Description (产品说明):	Work Cabinet
	工作掩门柜
Model Type (模具型号):	CBH X11

No:	Parts(零部件):	Material Specification(用料标准):
✓ 01	COUNTER TOP 柜台面	16GA. THK. SUS 304 S/S
02	LEG 支腿	Ø38mm 16 GA. THK. SUS 304 S/S TUBE
✓ 03	ADJUSTABLE FOOT INSERT 可调节嵌入式底脚	LUI CHUEN KEE (CHN)
✓ 04	REINFORCEMENT 加固件	16 GA. THK. SUS 304 S/S
05	SINK BOWL 洗碗槽	16 GA. THK. SUS 304 S/S
06	SINK WASTE 废料槽	
07	S.S. CROSS RAIL 横梁	Ø32mm 16 GA. THK. SUS 304 S/S TUBE
08	WALL MOUNTED BRACKET 壁装托架	16 GA. THK. SUS 304 S/S
✓ 09	UNDER SHELF 底架	18 GA. THK. SUS 304 S/S
10	MIXING FAUCET 混合龙头	
11	OVER SHELF 顶架	18 GA. THK. SUS 304 S/S
✓ 12	OUTER DOOR PANEL 外板	20 GA. THK. SUS 304 S/S
✓ 13	INNER DOOR PANEL 内板	22 GA. THK. SUS 304 S/S
✓ 14	CABINET BODY 柜身	20 GA. THK. SUS 304 S/S
15	CORNER BUMPER 拐角防护套	COLSON (CHN)
16	SWIVEL CASTOR 旋转角轮	GLOBE (CHN)
17	SOUND DEADEN MATERIAL 隔音材料	3mm THICKNESS
18	WALL FLASHING 防水面	20 GA. THK. SUS 304 S/S
19	CONDENSING UNIT 制冷机组	DANFOSS (CHN)
20	NOZZLE 排气口	Ø25mm SUS 304 S/S TUBE

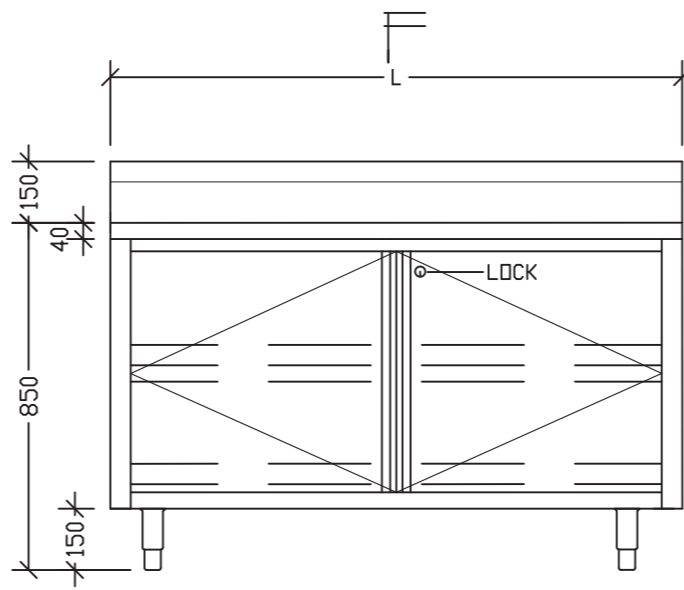

ELEVATION

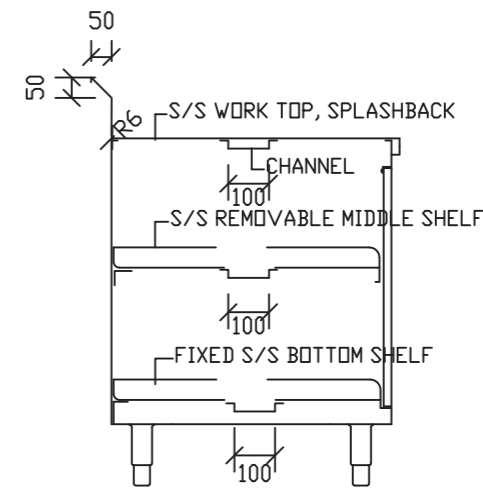

SECTION

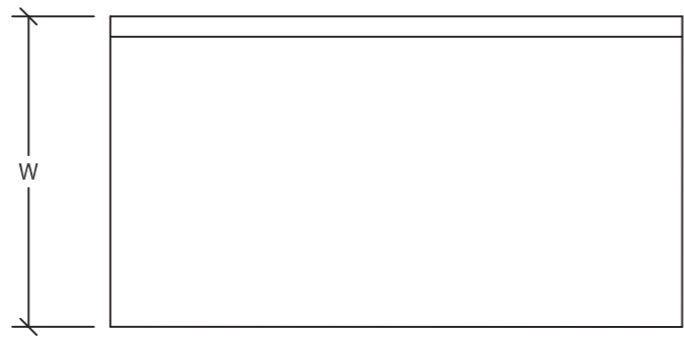

PLAN

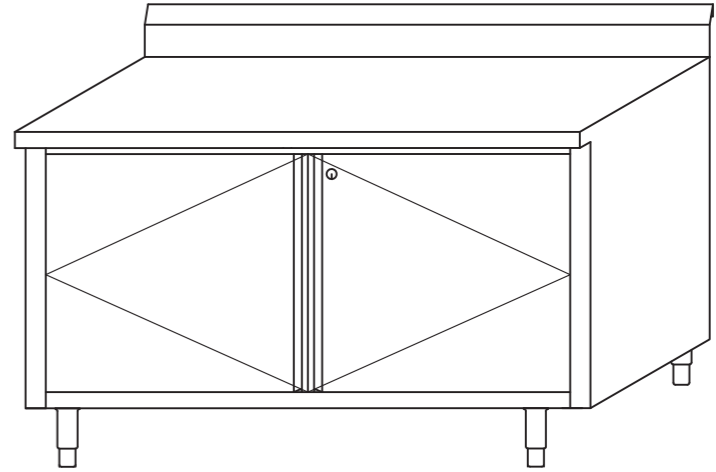

ISOMETRIC VIEW

No:	Item No(款号):	Qty(数量):	No:	Item No(款号):	Qty(数量):

Remark(备注):



SPOT WELDED A THREADED SHAFT TO THE UNDERSIDE OF WORK TOP / SHELF. THEN USE UNITS TO FIX WITH THE REINFORCEMENT / BRACKETS

技术说明:				SKU:			
1.所有产品边缘不能有毛刺, 覆膜面不能刮花;				名称:	建德C40+潜水俱乐部厨房		
2.公差要求标准: 符合GB/T G3280-2015不锈钢冷轧钢板和钢带标准中PT.A的公称宽度要求;				材料:			
3.所有标注尺寸为外尺寸;				编制:		日期:	
4.未注膜面方向朝外。				审核:		日期:	
A						视角:	☉
版本			批准	日期		版本:	A

STAINLESS STEEL SHOP DRAWING (CUSTOM)

不锈钢件生产要求图

Product Description (产品说明):	Dish Landing Table W/Double Sinks
	双星污碟台
Model Type (模具型号):	TDLSH2 AA03

No:	Parts(零部件):	Material Specfication(用料标准):
✓ 01	COUNTER TOP 柜台面	16GA. THK. SUS 304 S/S
✓ 02	LEG 支腿	∅38mm 16 GA. THK. SUS 304 S/S TUBE
✓ 03	ADJUSTABLE FOOT INSERT 可调节嵌入式底脚	LUI CHUEN KEE (CHN)
✓ 04	REINFORCEMENT 加固件	16 GA. THK. SUS 304 S/S
✓ 05	SINK BOWL 洗碗槽	16 GA. THK. SUS 304 S/S
06	SINK WASTE 废料槽	
✓ 07	S.S. CROSS RAIL 横梁	∅32mm 16 GA. THK. SUS 304 S/S TUBE
08	WALL MOUNTED BRACKET 壁装托架	16 GA. THK. SUS 304 S/S
09	UNDER SHELF 底架	18 GA. THK. SUS 304 S/S
✓ 10	MIXING FAUCET 混合龙头	
11	OVER SHELF 顶架	18 GA. THK. SUS 304 S/S
12	OUTER DOOR PANEL 外板	20 GA. THK. SUS 304 S/S
13	INNER DOOR PANEL 内板	22 GA. THK. SUS 304 S/S
14	CABINET BODY 柜身	20 GA. THK. SUS 304 S/S
15	CORNER BUMPER 拐角防护套	COLSON (CHN)
16	SWIVEL CASTOR 旋转角轮	GLOBE (CHN)
17	SOUND DEADEN MATERIAL 隔音材料	3mm THICKNESS
18	WALL FLASHING 防水面	20 GA. THK. SUS 304 S/S
19	CONDENSING UNIT 制冷机组	DANFOSS (CHN)
20	NOZZLE 排气口	∅25mm SUS 304 S/S TUBE

No:	Item No(款号):	Qty(数量):	No:	Item No(款号):	Qty(数量):

Remark(备注):

 M5

SPOT WELDED A THREADED SHAFT TO THE UNDERSIDE OF WORK TOP / SHELF. THEN USE UNITS TO FIX WITH THE REINFORCEMENT / BRACKETS

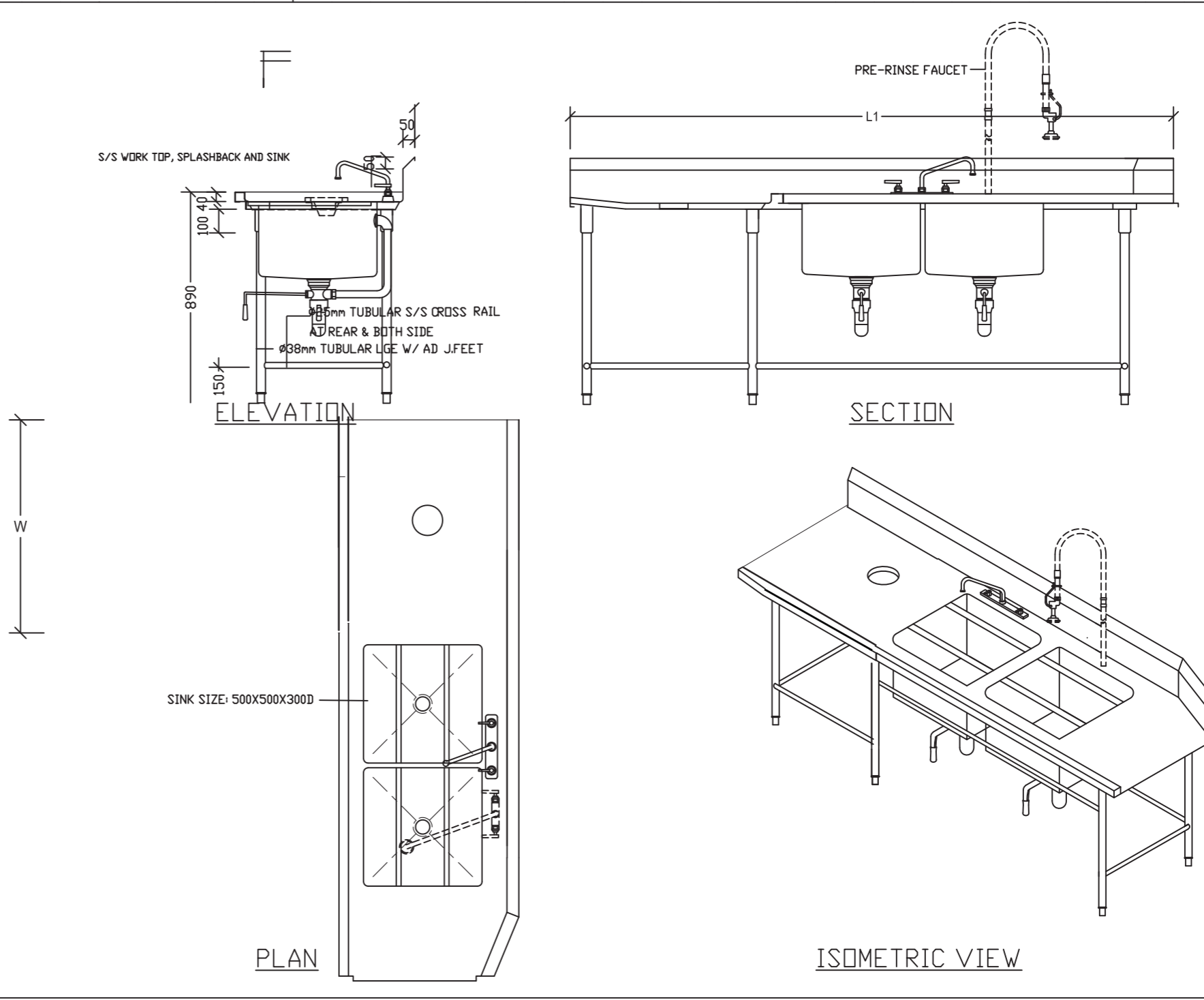

技术说明:				SKU:			
1.所有产品边缘不能有毛刺, 覆膜面不能刮花;				名称:	建德C40+潜水俱乐部厨房		
2.公差要求标准: 符合GB/T G3280-2015不锈钢冷轧钢板和钢带标准中PT.A的公称宽度要求;				材料:			
3.所有标注尺寸为外尺寸;				编制:		日期:	
4.未注膜面方向朝外。				审核:		日期:	
A						视角:	
版本		批准	日期			版本:	A

STAINLESS STEEL SHOP DRAWING (CUSTOM)

不锈钢件生产要求图

Product Description (产品说明):	Clean Dish Landing Table
	洁碟台
Model Type (模具型号):	TCL AA06

No:	Parts(零部件):	Material Specification(用料标准):
✓ 01	COUNTER TOP 柜台面	16GA. THK. SUS 304 S/S
✓ 02	LEG 支腿	Ø38mm 16 GA. THK. SUS 304 S/S TUBE
✓ 03	ADJUSTABLE FOOT INSERT 可调节嵌入式底脚	LUI CHUEN KEE (CHN)
✓ 04	REINFORCEMENT 加固件	16 GA. THK. SUS 304 S/S
05	SINK BOWL 洗碗槽	16 GA. THK. SUS 304 S/S
06	SINK WASTE 废料槽	
✓ 07	S.S. CROSS RAIL 横梁	Ø32mm 16 GA. THK. SUS 304 S/S TUBE
✓ 08	WALL MOUNTED BRACKET 壁装托架	16 GA. THK. SUS 304 S/S
09	UNDER SHELF 底架	18 GA. THK. SUS 304 S/S
10	MIXING FAUCET 混合龙头	
11	OVER SHELF 顶架	18 GA. THK. SUS 304 S/S
12	OUTER DOOR PANEL 外板	20 GA. THK. SUS 304 S/S
13	INNER DOOR PANEL 内板	22 GA. THK. SUS 304 S/S
14	CABINET BODY 柜身	20 GA. THK. SUS 304 S/S
15	CORNER BUMPER 拐角防护套	COLSON (CHN)
16	SWIVEL CASTOR 旋转角轮	GLOBE (CHN)
17	SOUND DEADEN MATERIAL 隔音材料	3mm THICKNESS
18	WALL FLASHING 防水面	20 GA. THK. SUS 304 S/S
19	CONDENSING UNIT 制冷机组	DANFOSS (CHN)
20	NOZZLE 排气口	Ø25mm SUS 304 S/S TUBE

No:	Item No(款号):	Qty(数量):	No:	Item No(款号):	Qty(数量):

Remark(备注):

 M5

SPOT WELDED A THREADED SHAFT TO THE UNDERSIDE OF WORK TOP / SHELF. THEN USE UNITS TO FIX WITH THE REINFORCEMENT / BRACKETS

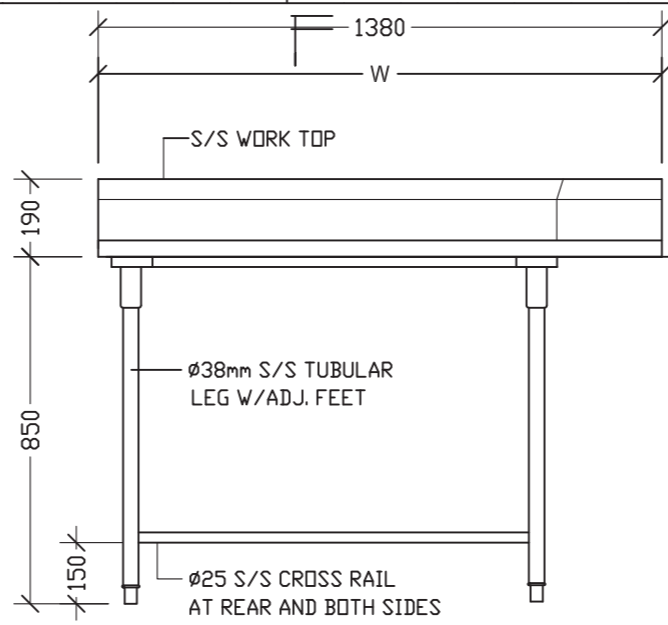

ELEVATION

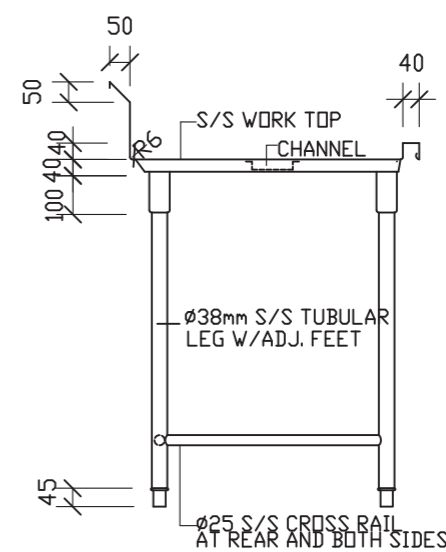

SECTION

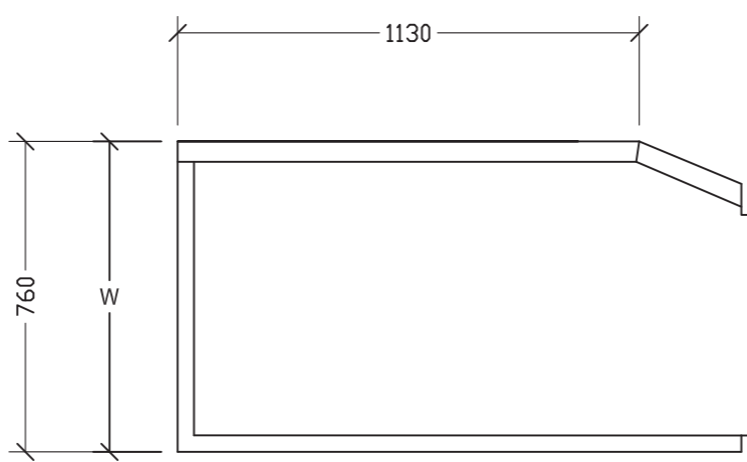

PLAN

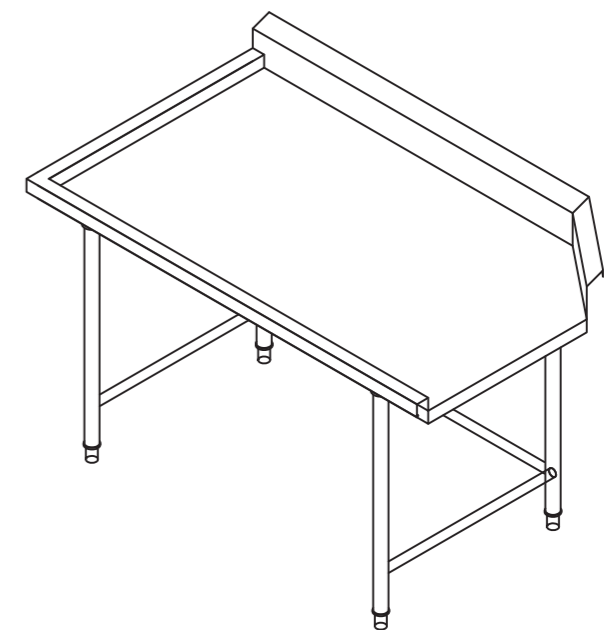

ISOMETRIC VIEW

技术说明:				SKU:			
1.所有产品边缘不能有毛刺, 覆膜面不能刮花;				名称:	建德C40+潜水俱乐部厨房		
2.公差要求标准: 符合GB/T G3280-2015不锈钢冷轧钢板和钢带标准中PT.A的公称宽度要求;				材料:			
3.所有标注尺寸为外尺寸;				编制:		日期:	
4.未注膜面方向朝外。				审核:		日期:	
A						视角:	
版本		批准	日期			版本:	A

STAINLESS STEEL SHOP DRAWING (CUSTOM)

不锈钢件生产要求图

Product Description (产品说明):	Work Table
	单层工作台
Model Type (模具型号):	TB AA07

No:	Parts(零部件):	Material Specfication(用料标准):
✓ 01	COUNTER TOP 柜台面	16GA. THK. SUS 304 S/S
✓ 02	LEG 支腿	∅38mm 16 GA. THK. SUS 304 S/S TUBE
✓ 03	ADJUSTABLE FOOT INSERT 可调节嵌入式底脚	LUI CHUEN KEE (CHN)
✓ 04	REINFORCEMENT 加固件	16 GA. THK. SUS 304 S/S
05	SINK BOWL 洗碗槽	16 GA. THK. SUS 304 S/S
06	SINK WASTE 废料槽	
✓ 07	S.S. CROSS RAIL 横梁	∅32mm 16 GA. THK. SUS 304 S/S TUBE
08	WALL MOUNTED BRACKET 壁装托架	16 GA. THK. SUS 304 S/S
09	UNDER SHELF 底架	18 GA. THK. SUS 304 S/S
10	MIXING FAUCET 混合龙头	
11	OVER SHELF 顶架	18 GA. THK. SUS 304 S/S
12	OUTER DOOR PANEL 外板	20 GA. THK. SUS 304 S/S
13	INNER DOOR PANEL 内板	22 GA. THK. SUS 304 S/S
14	CABINET BODY 柜身	20 GA. THK. SUS 304 S/S
15	CORNER BUMPER 拐角防护套	COLSON (CHN)
16	SWIVEL CASTOR 旋转角轮	GLOBE (CHN)
17	SOUND DEADEN MATERIAL 隔音材料	3mm THICKNESS
18	WALL FLASHING 防水面	20 GA. THK. SUS 304 S/S
19	CONDENSING UNIT 制冷机组	DANFOSS (CHN)
20	NOZZLE 排气口	∅25mm SUS 304 S/S TUBE

No:	Item No(款号):	Qty(数量):	No:	Item No(款号):	Qty(数量):

Remark(备注):

 M5

SPOT WELDED A THREADED SHAFT TO THE UNDERSIDE OF WORK TOP / SHELF. THEN USE UNITS TO FIX WITH THE REINFORCEMENT / BRACKETS

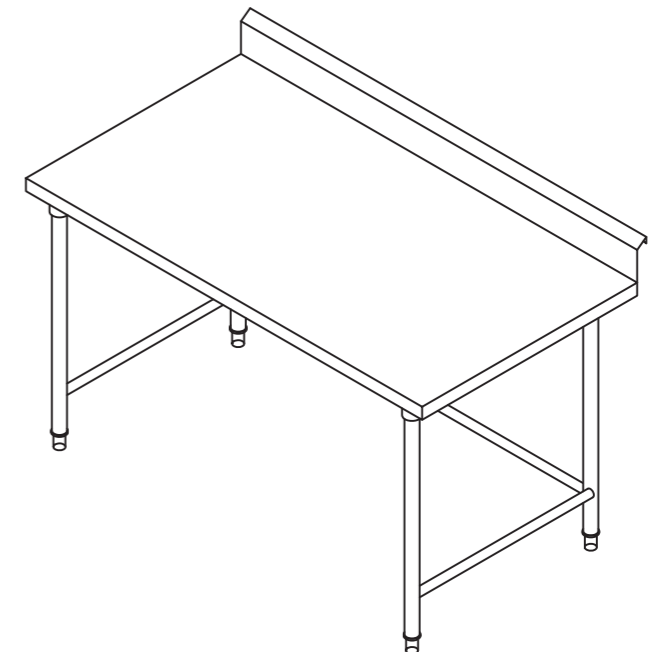
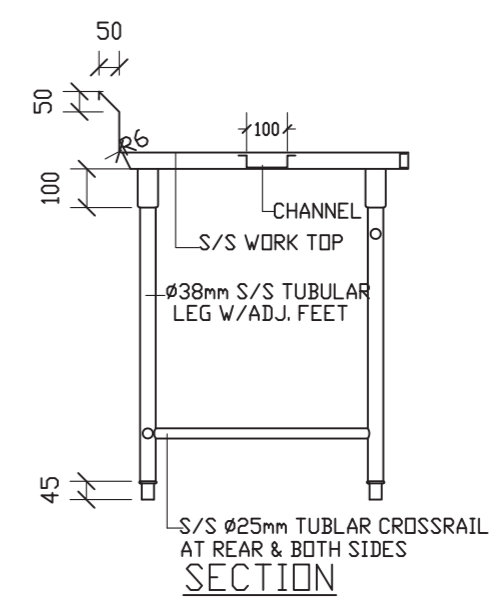
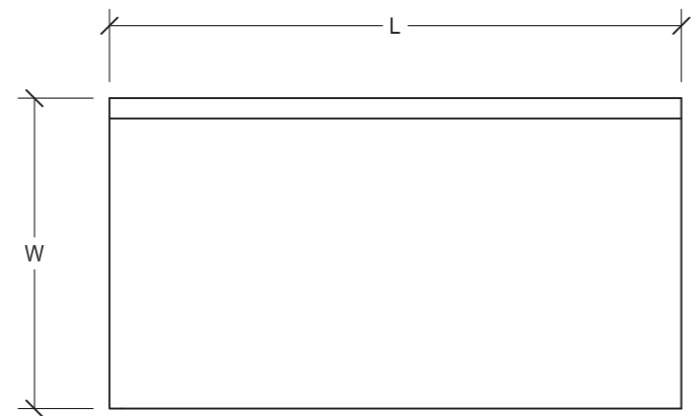
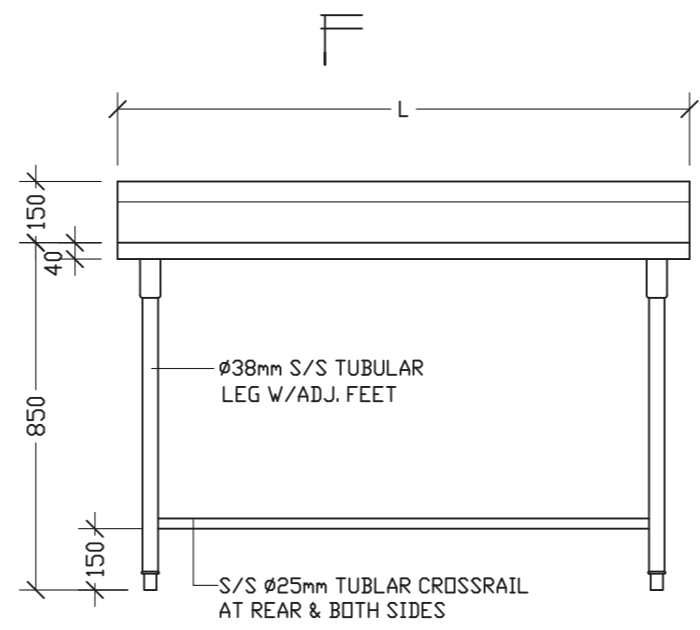

ISOMETRIC VIEW

技术说明:				SKU:			
1.所有产品边缘不能有毛刺, 覆膜面不能刮花;				名称:	建德C40+潜水俱乐部厨房		
2.公差要求标准: 符合GB/T G3280-2015不锈钢冷轧钢板和钢带标准中PT.A的公称宽度要求;				材料:			
3.所有标注尺寸为外尺寸;				编制:		日期:	
4.未注膜面方向朝外。				审核:		日期:	
A						视角:	
版本		批准	日期			版本:	A

STAINLESS STEEL SHOP DRAWING (CUSTOM)

不锈钢件生产要求图

Product Description (产品说明):	Wash Sink
	三星
Model Type (模具型号):	SPSC3P AA08

No:	Parts(零部件):	Material Specification(用料标准):
✓ 01	COUNTER TOP 柜台面	16GA. THK. SUS 304 S/S
✓ 02	LEG 支腿	∅38mm 16 GA. THK. SUS 304 S/S TUBE
✓ 03	ADJUSTABLE FOOT INSERT 可调节嵌入式底脚	LUI CHUEN KEE (CHN)
✓ 04	REINFORCEMENT 加固件	16 GA. THK. SUS 304 S/S
✓ 05	SINK BOWL 洗碗槽	16 GA. THK. SUS 304 S/S
06	SINK WASTE 废料槽	
✓ 07	S.S. CROSS RAIL 横梁	∅32mm 16 GA. THK. SUS 304 S/S TUBE
08	WALL MOUNTED BRACKET 壁挂托架	16 GA. THK. SUS 304 S/S
09	UNDER SHELF 底架	18 GA. THK. SUS 304 S/S
✓ 10	MIXING FAUCET 混合龙头	
✓ 11	OVER SHELF 顶架	18 GA. THK. SUS 304 S/S
12	OUTER DOOR PANEL 外板	20 GA. THK. SUS 304 S/S
13	INNER DOOR PANEL 内板	22 GA. THK. SUS 304 S/S
14	CABINET BODY 柜身	20 GA. THK. SUS 304 S/S
15	CORNER BUMPER 拐角防护套	COLSON (CHN)
16	SWIVEL CASTOR 旋转角轮	GLOBE (CHN)
17	SOUND DEADEN MATERIAL 隔音材料	3mm THICKNESS
18	WALL FLASHING 防水面	20 GA. THK. SUS 304 S/S
19	CONDENSING UNIT 制冷机组	DANFOSS (CHN)
20	NOZZLE 排气口	∅25mm SUS 304 S/S TUBE

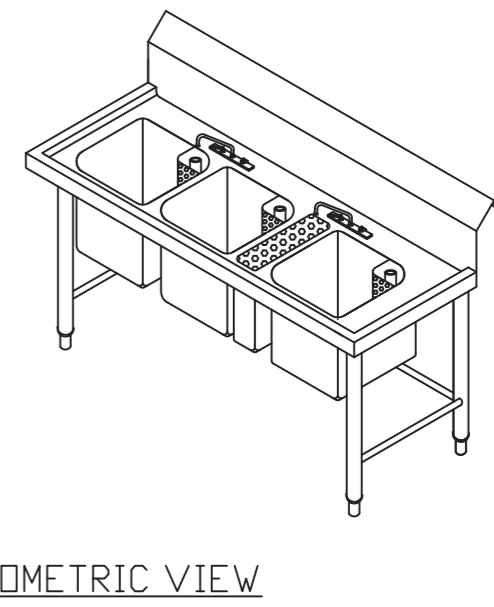
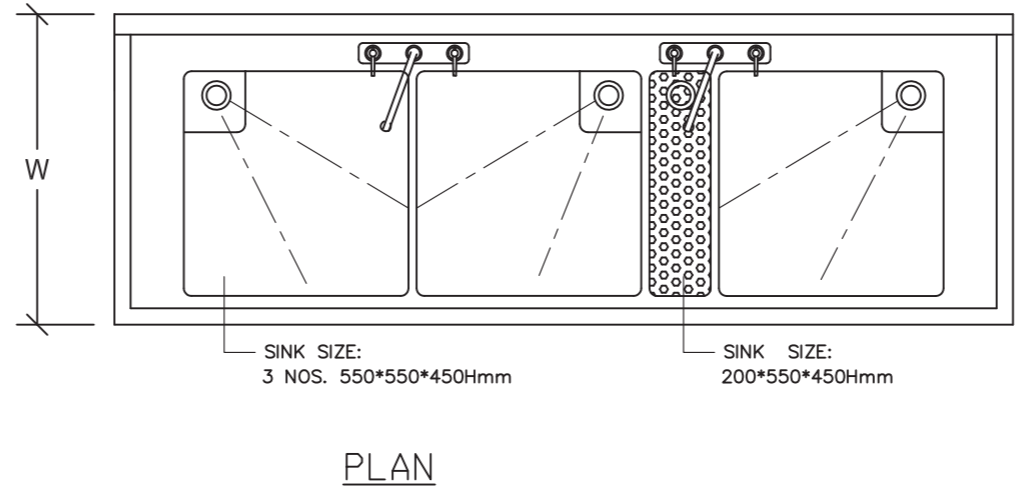
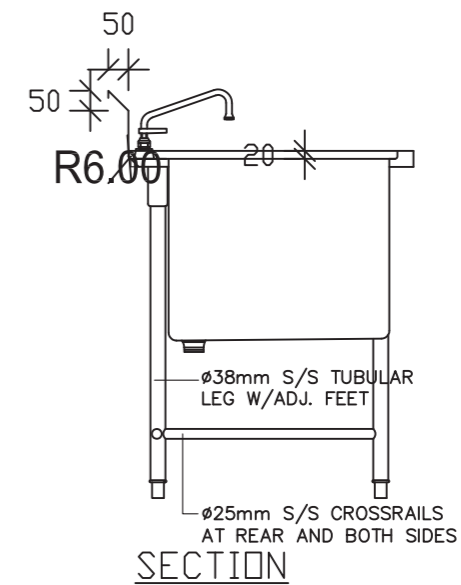
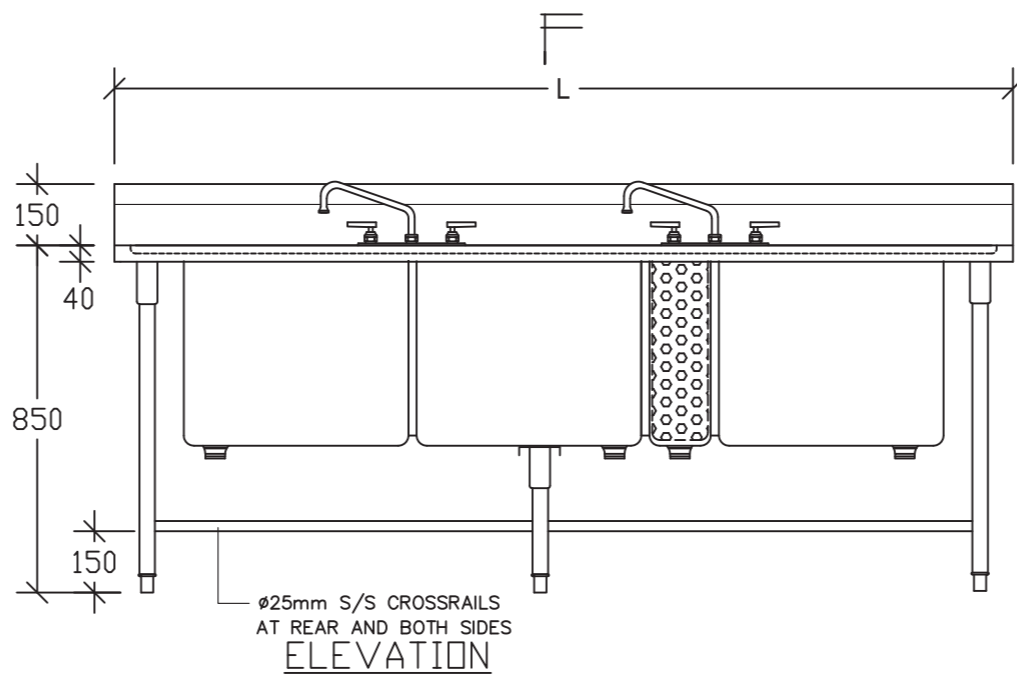

No:	Item No(款号):	Qty(数量):	No:	Item No(款号):	Qty(数量):

Remark(备注):

M5

SPOT WELDED A THREADED SHAFT TO THE UNDERSIDE OF WORK TOP / SHELF. THEN USE UNITS TO FIX WITH THE REINFORCEMENT / BRACKETS

技术说明:				SKU:			
1.所有产品边缘不能有毛刺, 覆膜面不能刮花;				名称:	建德C40+潜水俱乐部厨房		
2.公差要求标准: 符合GB/T G3280-2015不锈钢冷轧钢板和钢带标准中PT.A的公称宽度要求;				材料:			
3.所有标注尺寸为外尺寸;				编制:		日期:	
4.未注膜面方向朝外。				审核:		日期:	
A						视角:	☉
版本		批准	日期			版本:	A

STAINLESS STEEL SHOP DRAWING (CUSTOM)

不锈钢件生产要求图

Product Description (产品说明):	Single Wall Mounted Shelving
	单层挂墙层架
Model Type (模具型号):	JBW1 AA09

No:	Parts(零部件):	Material Specification(用料标准):
01	COUNTER TOP 柜台面	16GA. THK. SUS 304 S/S
02	LEG 支腿	∅38mm 16 GA. THK. SUS 304 S/S TUBE
03	ADJUSTABLE FOOT INSERT 可调节嵌入式底脚	LUI CHUEN KEE (CHN)
✓ 04	REINFORCEMENT 加固件	16 GA. THK. SUS 304 S/S
05	SINK BOWL 洗碗槽	16 GA. THK. SUS 304 S/S
06	SINK WASTE 废料槽	
07	S.S. CROSS RAIL 横梁	∅32mm 16 GA. THK. SUS 304 S/S TUBE
✓ 08	WALL MOUNTED BRACKET 壁装托架	16 GA. THK. SUS 304 S/S
09	UNDER SHELF 底架	18 GA. THK. SUS 304 S/S
10	MIXING FAUCET 混合龙头	
✓ 11	OVER SHELF 顶架	18 GA. THK. SUS 304 S/S
12	OUTER DOOR PANEL 外板	20 GA. THK. SUS 304 S/S
13	INNER DOOR PANEL 内板	22 GA. THK. SUS 304 S/S
14	CABINET BODY 柜身	20 GA. THK. SUS 304 S/S
15	CORNER BUMPER 拐角防护套	COLSON (CHN)
16	SWIVEL CASTOR 旋转角轮	GLOBE (CHN)
17	SOUND DEADEN MATERIAL 隔音材料	3mm THICKNESS
18	WALL FLASHING 防水面	20 GA. THK. SUS 304 S/S
19	CONDENSING UNIT 制冷机组	DANFOSS (CHN)
20	NOZZLE 排气口	∅25mm SUS 304 S/S TUBE

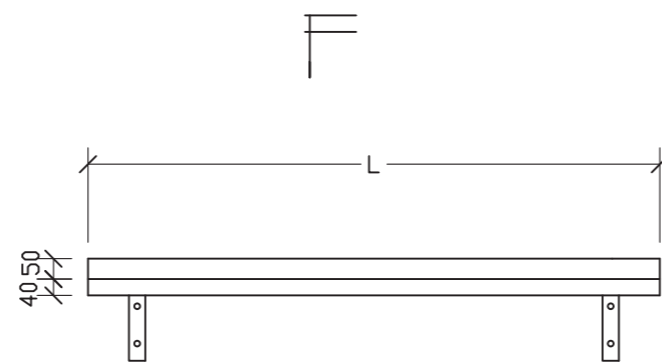

ELEVATION

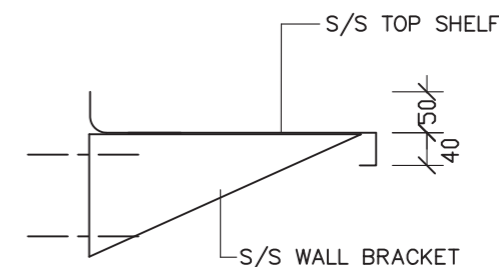

SECTION

No:	Item No(款号):	Qty(数量):	No:	Item No(款号):	Qty(数量):

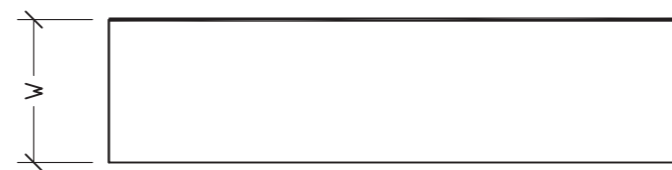

PLAN

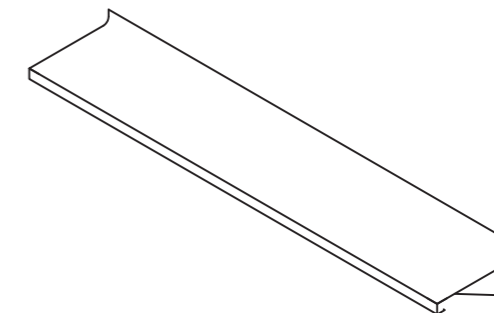

ISOMETRIC VIEW

Remark(备注):



SPOT WELDED A THREADED SHAFT TO THE UNDERSIDE OF WORK TOP / SHELF. THEN USE UNITS TO FIX WITH THE REINFORCEMENT / BRACKETS

技术说明:				SKU:			
1.所有产品边缘不能有毛刺, 覆膜面不能刮花;				名称:	建德C40+潜水俱乐部厨房		
2.公差要求标准: 符合GB/T G3280-2015不锈钢冷轧钢板和钢带标准中PT.A的公称宽度要求;				材料:			
3.所有标注尺寸为外尺寸;				编制:		日期:	
4.未注膜面方向朝外。				审核:		日期:	
A						视角:	☉
版本		批准	日期			版本:	A

STAINLESS STEEL SHOP DRAWING (CUSTOM)

不锈钢件生产要求图

Product Description (产品说明):	4-Tier Square Tube Storage Shelving
	四层通架
Model Type (模具型号):	JFG4 AA10

No:	Parts(零部件):	Material Specification(用料标准):
01	COUNTER TOP 柜台面	16GA. THK. SUS 304 S/S
✓ 02	LEG 支腿	∅38mm 16 GA. THK. SUS 304 S/S TUBE
✓ 03	ADJUSTABLE FOOT INSERT 可调节嵌入式底脚	LUI CHUEN KEE (CHN)
04	REINFORCEMENT 加固件	16 GA. THK. SUS 304 S/S
05	SINK BOWL 洗碗槽	16 GA. THK. SUS 304 S/S
06	SINK WASTE 废料槽	
✓ 07	S.S. CROSS RAIL 横梁	∅32mm 16 GA. THK. SUS 304 S/S TUBE
08	WALL MOUNTED BRACKET 壁装托架	16 GA. THK. SUS 304 S/S
09	UNDER SHELF 底架	18 GA. THK. SUS 304 S/S
10	MIXING FAUCET 混合龙头	
11	OVER SHELF 顶架	18 GA. THK. SUS 304 S/S
12	OUTER DOOR PANEL 外板	20 GA. THK. SUS 304 S/S
13	INNER DOOR PANEL 内板	22 GA. THK. SUS 304 S/S
14	CABINET BODY 柜身	20 GA. THK. SUS 304 S/S
15	CORNER BUMPER 拐角防护套	COLSON (CHN)
16	SWIVEL CASTOR 旋转角轮	GLOBE (CHN)
17	SOUND DEADEN MATERIAL 隔音材料	3mm THICKNESS
18	WALL FLASHING 防水面	20 GA. THK. SUS 304 S/S
19	CONDENSING UNIT 制冷机组	DANFOSS (CHN)
20	NOZZLE 排气口	∅25mm SUS 304 S/S TUBE

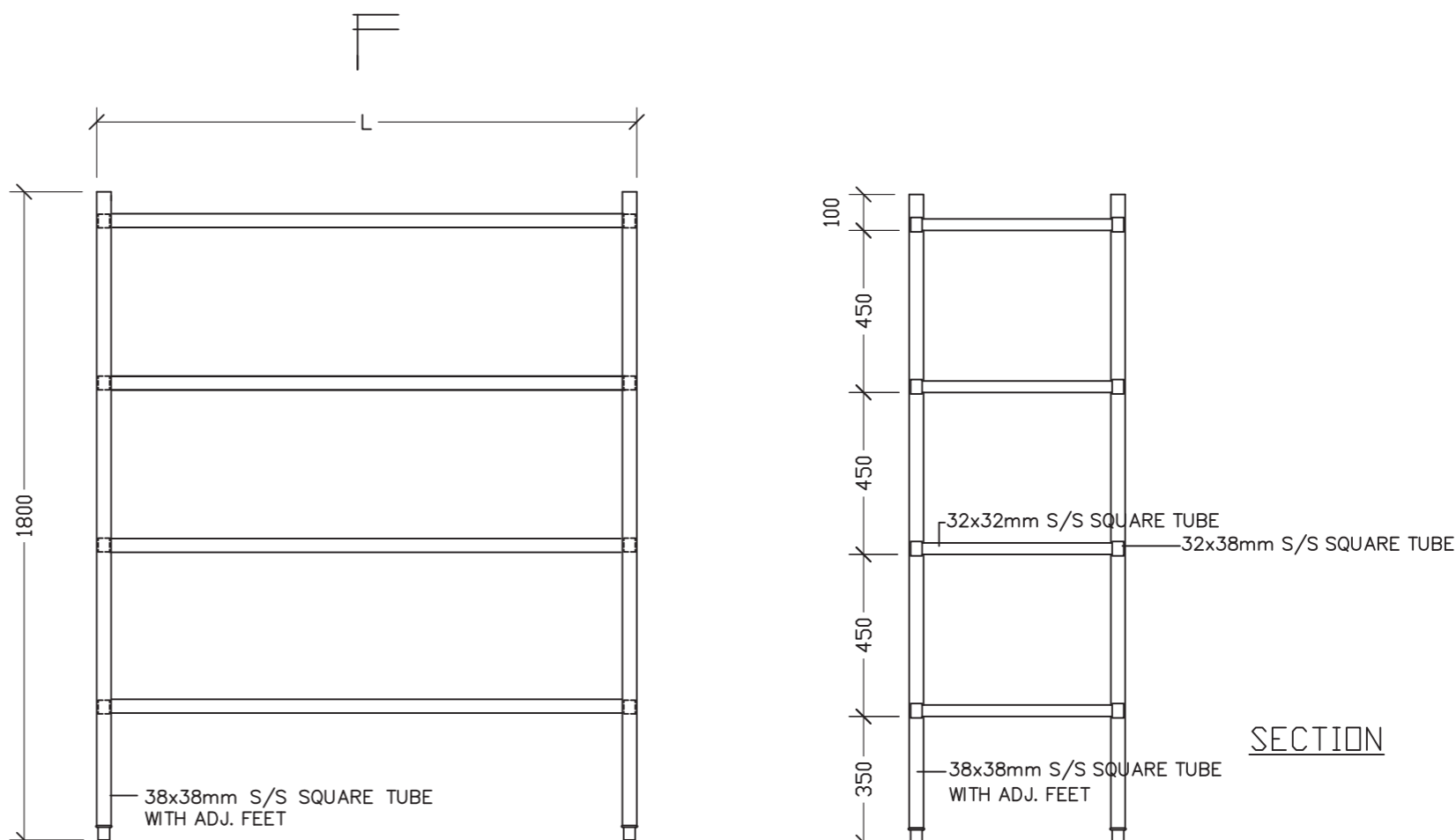

No:	Item No(款号):	Qty(数量):	No:	Item No(款号):	Qty(数量):

Remark(备注):



M5

SPOT WELDED A THREADED SHAFT TO THE UNDERSIDE OF WORK TOP / SHELF. THEN USE UNITS TO FIX WITH THE REINFORCEMENT / BRACKETS

ELEVATION

PLAN

SECTION

技术说明:				SKU:			
1.所有产品边缘不能有毛刺, 覆膜面不能刮花;				名称:	建德C40+潜水俱乐部厨房		
2.公差要求标准: 符合GB/T G3280-2015不锈钢冷轧钢板和钢带标准中PT.A的公称宽度要求;				材料:			
3.所有标注尺寸为外尺寸;				编制:		日期:	
4.未注膜面方向朝外。				审核:		日期:	
A						视角:	☉
版本		批准	日期			版本:	A

STAINLESS STEEL SHOP DRAWING (CUSTOM)

不锈钢件生产要求图

Product Description (产品说明):	Uright Storage Cabinet
	高身储物柜
Model Type (模具型号):	CUS AA11

No:	Parts(零部件):	Material Specfication(用料标准):
✓ 01	COUNTER TOP 柜台面	16GA. THK. SUS 304 S/S
02	LEG 支腿	∅38mm 16 GA. THK. SUS 304 S/S TUBE
✓ 03	ADJUSTABLE FOOT INSERT 可调节嵌入式底脚	LUI CHUEN KEE (CHN)
✓ 04	REINFORCEMENT 加固件	16 GA. THK. SUS 304 S/S
05	SINK BOWL 洗碗槽	16 GA. THK. SUS 304 S/S
06	SINK WASTE 废料槽	
07	S.S. CROSS RAIL 横梁	∅32mm 16 GA. THK. SUS 304 S/S TUBE
08	WALL MOUNTED BRACKET 壁装托架	16 GA. THK. SUS 304 S/S
✓ 09	UNDER SHELF 底架	18 GA. THK. SUS 304 S/S
10	MIXING FAUCET 混合龙头	
11	OVER SHELF 顶架	18 GA. THK. SUS 304 S/S
✓ 12	OUTER DOOR PANEL 外板	20 GA. THK. SUS 304 S/S
✓ 13	INNER DOOR PANEL 内板	22 GA. THK. SUS 304 S/S
✓ 14	CABINET BODY 柜身	20 GA. THK. SUS 304 S/S
15	CORNER BUMPER 拐角防护套	COLSON (CHN)
16	SWIVEL CASTOR 旋转角轮	GLOBE (CHN)
17	SOUND DEADEN MATERIAL 隔音材料	3mm THICKNESS
18	WALL FLASHING 防水面	20 GA. THK. SUS 304 S/S
19	CONDENSING UNIT 制冷机组	DANFOSS (CHN)
20	NOZZLE 排气口	∅25mm SUS 304 S/S TUBE

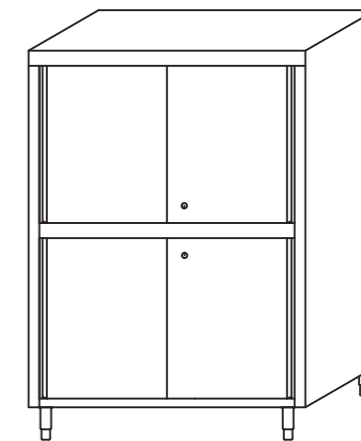
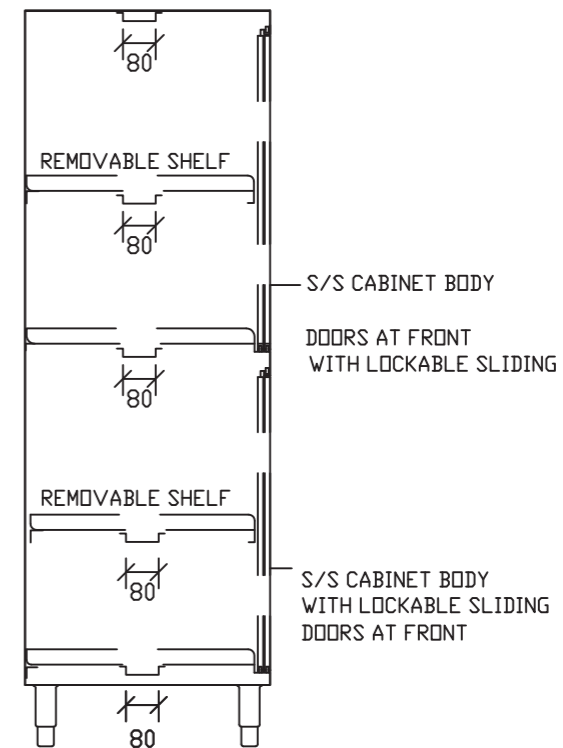
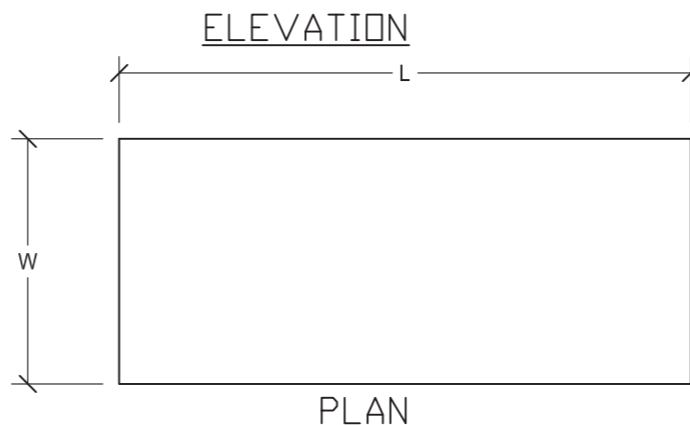
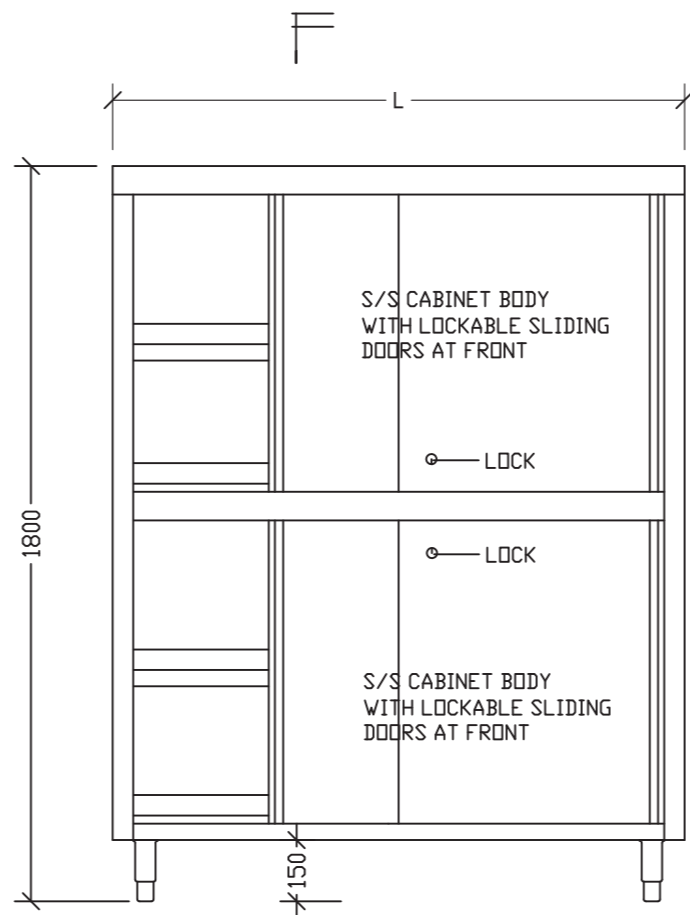

No:	Item No(款号):	Qty(数量):	No:	Item No(款号):	Qty(数量):

Remark(备注):



SPOT WELDED A THREADED SHAFT TO THE UNDERSIDE OF WORK TOP / SHELF. THEN USE UNITS TO FIX WITH THE REINFORCEMENT / BRACKETS

技术说明:				SKU:			
1.所有产品边缘不能有毛刺, 覆膜面不能刮花;				名称:	建德C40+潜水俱乐部厨房		
2.公差要求标准: 符合GB/T G3280-2015不锈钢冷轧钢板和钢带标准中PT.A的公称宽度要求;				材料:			
3.所有标注尺寸为外尺寸;				编制:		日期:	
4.未注膜面方向朝外。				审核:		日期:	
A						视角:	☉
版本		批准	日期			版本:	A

STAINLESS STEEL SHOP DRAWING (CUSTOM)

不锈钢件生产要求图

Product Description (产品说明):	Work Table W/Twin Sinks
	工作台连单星盆 (中间去水)
Model Type (模具型号):	STSH1 BB02

No:	Parts(零部件):	Material Specfication(用料标准):
✓ 01	COUNTER TOP 柜台面	16GA. THK. SUS 304 S/S
✓ 02	LEG 支腿	∅38mm 16 GA. THK. SUS 304 S/S TUBE
✓ 03	ADJUSTABLE FOOT INSERT 可调节嵌入式底脚	LUI CHUEN KEE (CHN)
✓ 04	REINFORCEMENT 加固件	16 GA. THK. SUS 304 S/S
✓ 05	SINK BOWL 洗碗槽	16 GA. THK. SUS 304 S/S
06	SINK WASTE 废料槽	
✓ 07	S.S. CROSS RAIL 横梁	∅32mm 16 GA. THK. SUS 304 S/S TUBE
08	WALL MOUNTED BRACKET 壁装托架	16 GA. THK. SUS 304 S/S
09	UNDER SHELF 底架	18 GA. THK. SUS 304 S/S
✓ 10	MIXING FAUCET 混合龙头	
11	OVER SHELF 顶架	18 GA. THK. SUS 304 S/S
12	OUTER DOOR PANEL 外板	20 GA. THK. SUS 304 S/S
13	INNER DOOR PANEL 内板	22 GA. THK. SUS 304 S/S
14	CABINET BODY 柜身	20 GA. THK. SUS 304 S/S
15	CORNER BUMPER 拐角防护套	COLSON (CHN)
16	SWIVEL CASTOR 旋转角轮	GLOBE (CHN)
17	SOUND DEADEN MATERIAL 隔音材料	3mm THICKNESS
18	WALL FLASHING 防水面	20 GA. THK. SUS 304 S/S
19	CONDENSING UNIT 制冷机组	DANFOSS (CHN)
20	NOZZLE 排气口	∅25mm SUS 304 S/S TUBE

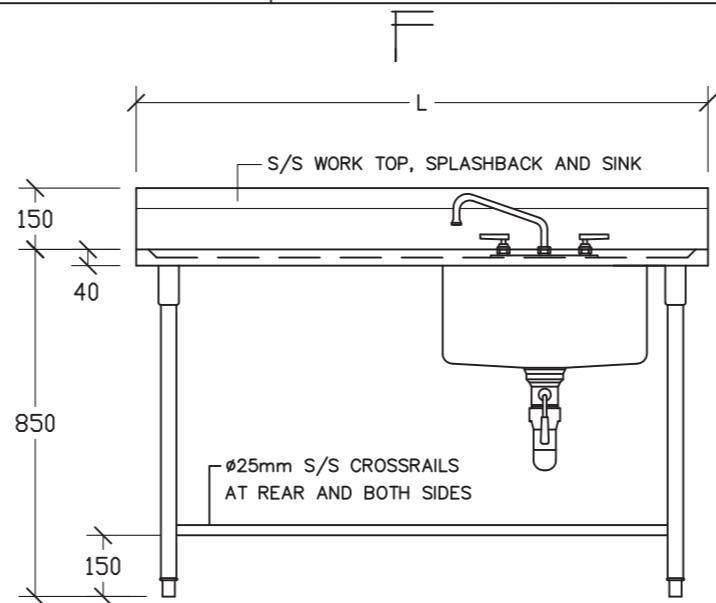

ELEVATION

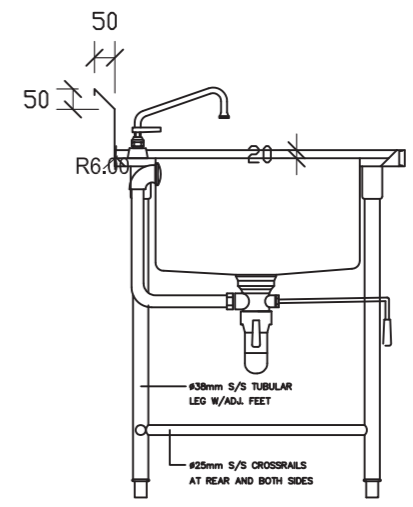

SECTION

No:	Item No(款号):	Qty(数量):	No:	Item No(款号):	Qty(数量):

Remark(备注):

 M5

SPOT WELDED A THREADED SHAFT TO THE UNDERSIDE OF WORK TOP / SHELF. THEN USE UNITS TO FIX WITH THE REINFORCEMENT / BRACKETS

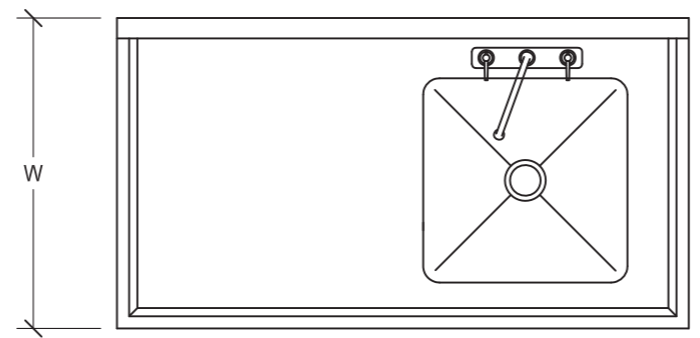

PLAN

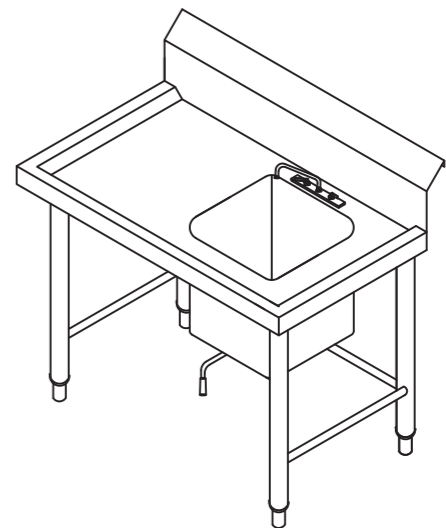

ISOMETRIC VIEW

技术说明:				SKU:			
1.所有产品边缘不能有毛刺, 覆膜面不能刮花;				名称:	建德C40+潜水俱乐部厨房		
2.公差要求标准: 符合GB/T G3280-2015不锈钢冷轧钢板和钢带标准中PT.A的公称宽度要求;				材料:			
3.所有标注尺寸为外尺寸;				编制:		日期:	
4.未注膜面方向朝外。				审核:		日期:	
A						视角:	
版本		批准	日期			版本:	A

STAINLESS STEEL SHOP DRAWING (CUSTOM)

不锈钢件生产要求图

Product Description (产品说明):	Work Cabinet
	工作掩门柜
Model Type (模具型号):	CBH BB05

No:	Parts(零部件):	Material Specification(用料标准):
✓ 01	COUNTER TOP 柜台面	16GA. THK. SUS 304 S/S
02	LEG 支腿	Ø38mm 16 GA. THK. SUS 304 S/S TUBE
✓ 03	ADJUSTABLE FOOT INSERT 可调节嵌入式底脚	LUI CHUEN KEE (CHN)
✓ 04	REINFORCEMENT 加固件	16 GA. THK. SUS 304 S/S
05	SINK BOWL 洗碗槽	16 GA. THK. SUS 304 S/S
06	SINK WASTE 废料槽	
07	S.S. CROSS RAIL 横梁	Ø32mm 16 GA. THK. SUS 304 S/S TUBE
08	WALL MOUNTED BRACKET 壁装托架	16 GA. THK. SUS 304 S/S
✓ 09	UNDER SHELF 底架	18 GA. THK. SUS 304 S/S
10	MIXING FAUCET 混合龙头	
11	OVER SHELF 顶架	18 GA. THK. SUS 304 S/S
✓ 12	OUTER DOOR PANEL 外板	20 GA. THK. SUS 304 S/S
✓ 13	INNER DOOR PANEL 内板	22 GA. THK. SUS 304 S/S
✓ 14	CABINET BODY 柜身	20 GA. THK. SUS 304 S/S
15	CORNER BUMPER 拐角防护套	COLSON (CHN)
16	SWIVEL CASTOR 旋转角轮	GLOBE (CHN)
17	SOUND DEADEN MATERIAL 隔音材料	3mm THICKNESS
18	WALL FLASHING 防水面	20 GA. THK. SUS 304 S/S
19	CONDENSING UNIT 制冷机组	DANFOSS (CHN)
20	NOZZLE 排气口	Ø25mm SUS 304 S/S TUBE

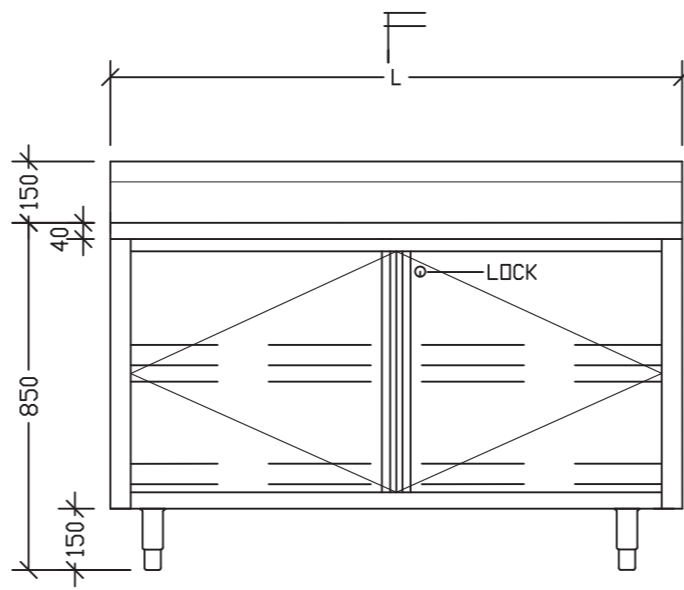

ELEVATION

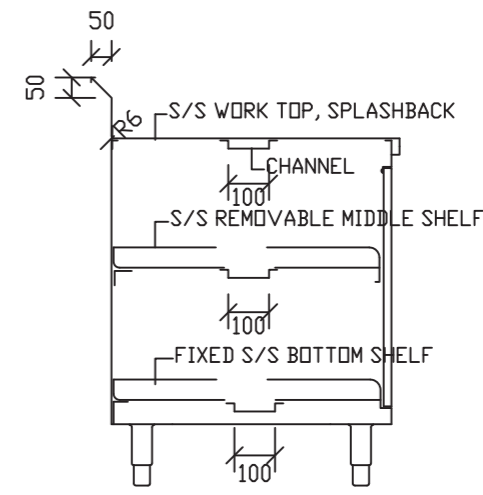

SECTION

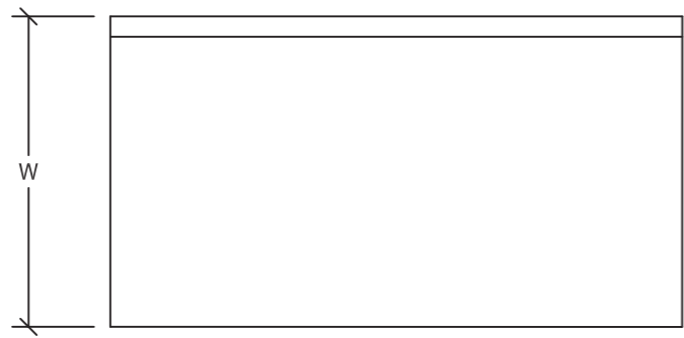

PLAN

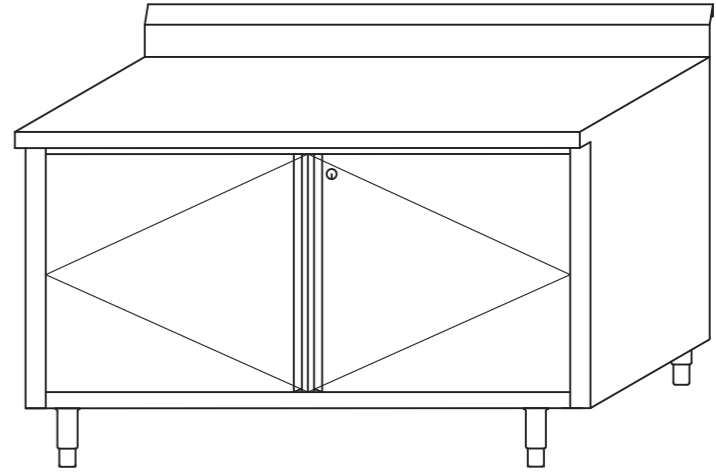

ISOMETRIC VIEW

No:	Item No(款号):	Qty(数量):	No:	Item No(款号):	Qty(数量):

Remark(备注):



SPOT WELDED A THREADED SHAFT TO THE UNDERSIDE OF WORK TOP / SHELF. THEN USE UNITS TO FIX WITH THE REINFORCEMENT / BRACKETS

技术说明:				SKU:			
1.所有产品边缘不能有毛刺, 覆膜面不能刮花;				名称:	建德C40+潜水俱乐部厨房		
2.公差要求标准: 符合GB/T G3280-2015不锈钢冷轧钢板和钢带标准中PT.A的公称宽度要求;				材料:			
3.所有标注尺寸为外尺寸;				编制:		日期:	
4.未注膜面方向朝外。				审核:		日期:	
A						视角:	☉
版本		批准	日期			版本:	A

STAINLESS STEEL SHOP DRAWING (CUSTOM)

不锈钢件生产要求图

Product Description (产品说明):	Work Cabinet
	工作掩门柜
Model Type (模具型号):	CBH BB07

No:	Parts(零部件):	Material Specification(用料标准):
✓ 01	COUNTER TOP 柜台面	16GA. THK. SUS 304 S/S
02	LEG 支腿	Ø38mm 16 GA. THK. SUS 304 S/S TUBE
✓ 03	ADJUSTABLE FOOT INSERT 可调节嵌入式底脚	LUI CHUEN KEE (CHN)
✓ 04	REINFORCEMENT 加固件	16 GA. THK. SUS 304 S/S
05	SINK BOWL 洗碗槽	16 GA. THK. SUS 304 S/S
06	SINK WASTE 废料槽	
07	S.S. CROSS RAIL 横梁	Ø32mm 16 GA. THK. SUS 304 S/S TUBE
08	WALL MOUNTED BRACKET 壁装托架	16 GA. THK. SUS 304 S/S
✓ 09	UNDER SHELF 底架	18 GA. THK. SUS 304 S/S
10	MIXING FAUCET 混合龙头	
11	OVER SHELF 顶架	18 GA. THK. SUS 304 S/S
✓ 12	OUTER DOOR PANEL 外板	20 GA. THK. SUS 304 S/S
✓ 13	INNER DOOR PANEL 内板	22 GA. THK. SUS 304 S/S
✓ 14	CABINET BODY 柜身	20 GA. THK. SUS 304 S/S
15	CORNER BUMPER 拐角防护套	COLSON (CHN)
16	SWIVEL CASTOR 旋转角轮	GLOBE (CHN)
17	SOUND DEADEN MATERIAL 隔音材料	3mm THICKNESS
18	WALL FLASHING 防水面	20 GA. THK. SUS 304 S/S
19	CONDENSING UNIT 制冷机组	DANFOSS (CHN)
20	NOZZLE 排气口	Ø25mm SUS 304 S/S TUBE

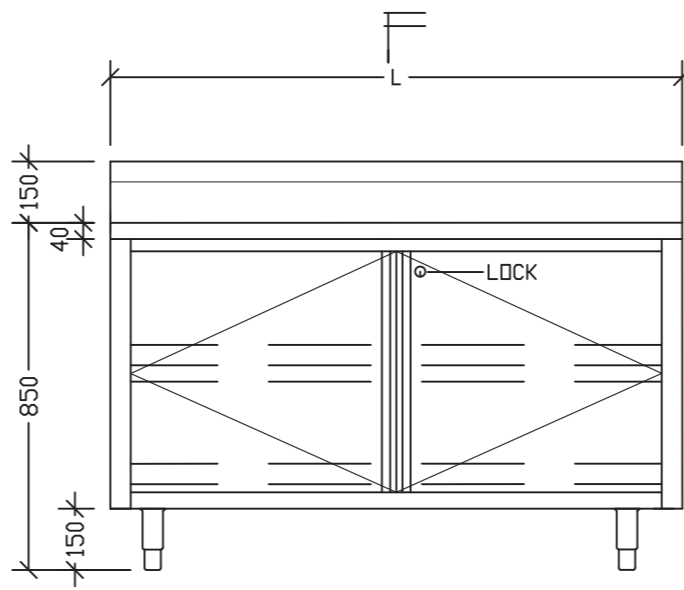

ELEVATION

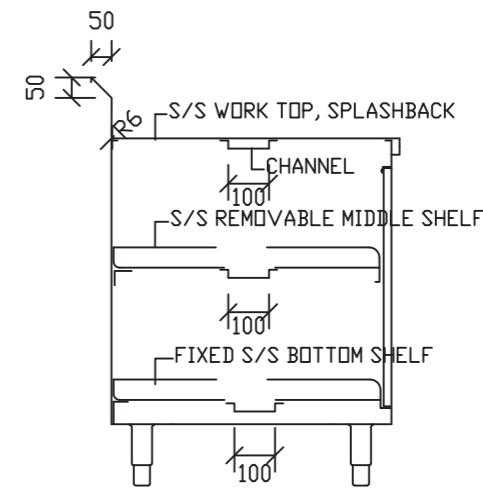

SECTION

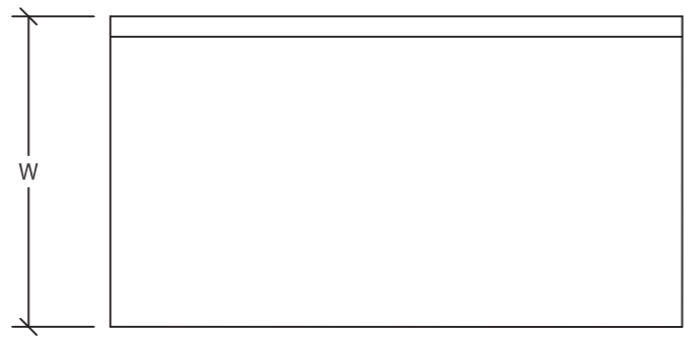

PLAN

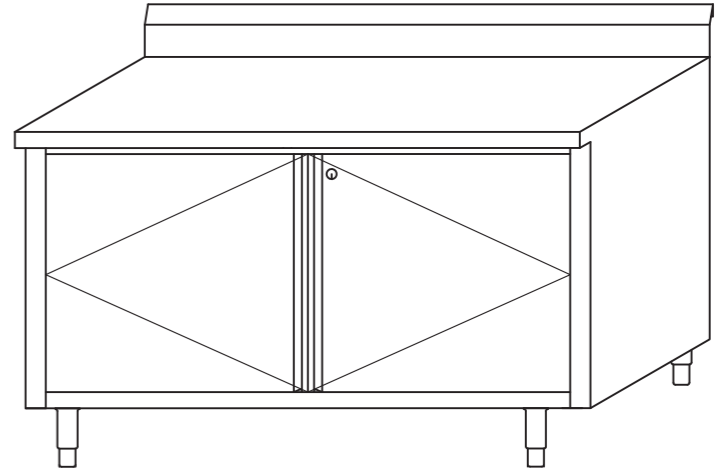

ISOMETRIC VIEW

No:	Item No(款号):	Qty(数量):	No:	Item No(款号):	Qty(数量):

Remark(备注):



SPOT WELDED A THREADED SHAFT TO THE UNDERSIDE OF WORK TOP / SHELF. THEN USE UNITS TO FIX WITH THE REINFORCEMENT / BRACKETS

技术说明:				SKU:			
1.所有产品边缘不能有毛刺, 覆膜面不能刮花;				名称:	建德C40+潜水俱乐部厨房		
2.公差要求标准: 符合GB/T G3280-2015不锈钢冷轧钢板和钢带标准中PT.A的公称宽度要求;				材料:			
3.所有标注尺寸为外尺寸;				编制:		日期:	
4.未注膜面方向朝外。				审核:		日期:	
A						视角:	☉
版本			批准	日期		版本:	A

STAINLESS STEEL SHOP DRAWING (CUSTOM)

不锈钢件生产要求图

Product Description (产品说明):	Work Table W/Under Shelf
	调料平台
Model Type (模具型号):	TBS1 BB10

No:	Parts(零部件):	Material Specification(用料标准):
✓ 01	COUNTER TOP 柜台面	16GA. THK. SUS 304 S/S
✓ 02	LEG 支腿	Ø38mm 16 GA. THK. SUS 304 S/S TUBE
✓ 03	ADJUSTABLE FOOT INSERT 可调节嵌入式底脚	LUI CHUEN KEE (CHN)
✓ 04	REINFORCEMENT 加固件	16 GA. THK. SUS 304 S/S
05	SINK BOWL 洗碗槽	16 GA. THK. SUS 304 S/S
06	SINK WASTE 废料槽	
✓ 07	S.S. CROSS RAIL 横梁	Ø32mm 16 GA. THK. SUS 304 S/S TUBE
08	WALL MOUNTED BRACKET 壁装托架	16 GA. THK. SUS 304 S/S
09	UNDER SHELF 底架	18 GA. THK. SUS 304 S/S
10	MIXING FAUCET 混合龙头	
11	OVER SHELF 顶架	18 GA. THK. SUS 304 S/S
12	OUTER DOOR PANEL 外板	20 GA. THK. SUS 304 S/S
13	INNER DOOR PANEL 内板	22 GA. THK. SUS 304 S/S
14	CABINET BODY 柜身	20 GA. THK. SUS 304 S/S
15	CORNER BUMPER 拐角防护套	COLSON (CHN)
16	SWIVEL CASTOR 旋转角轮	GLOBE (CHN)
17	SOUND DEADEN MATERIAL 隔音材料	3mm THICKNESS
18	WALL FLASHING 防水面	20 GA. THK. SUS 304 S/S
19	CONDENSING UNIT 制冷机组	DANFOSS (CHN)
20	NOZZLE 排气口	Ø25mm SUS 304 S/S TUBE

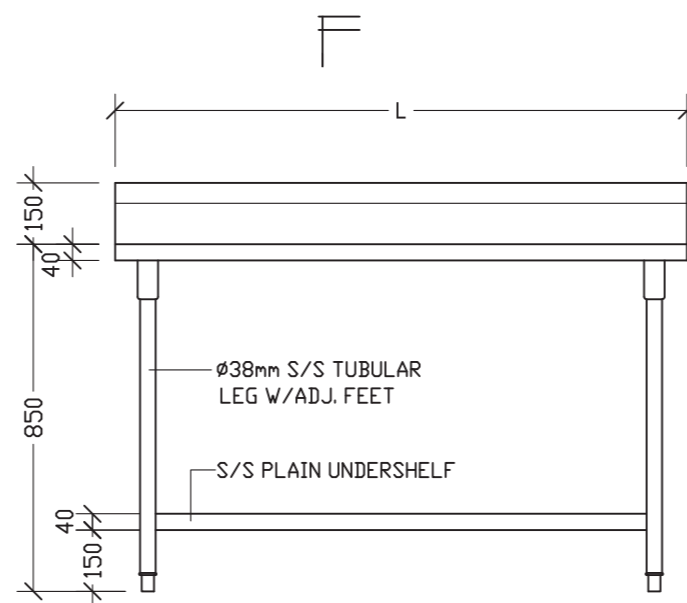

ELEVATION

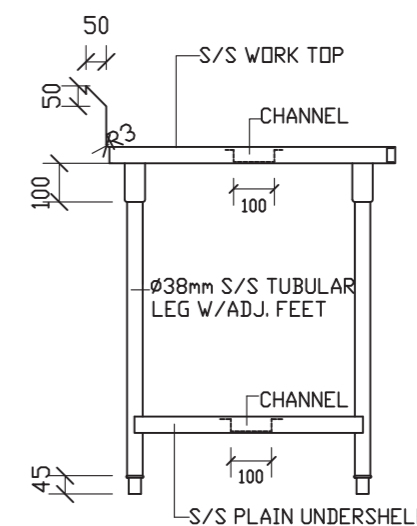

SECTION

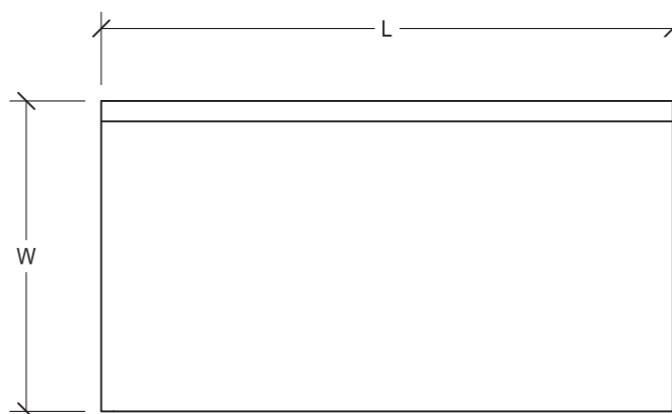

PLAN

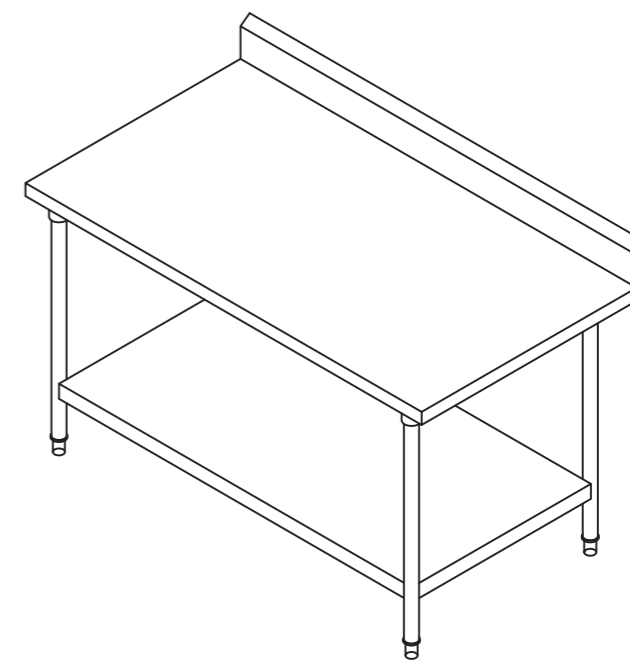

ISOMETRIC VIEW

No:	Item No(款号):	Qty(数量):	No:	Item No(款号):	Qty(数量):

Remark(备注):



SPOT WELDED A THREADED SHAFT TO THE UNDERSIDE OF WORK TOP / SHELF. THEN USE UNITS TO FIX WITH THE REINFORCEMENT / BRACKETS

技术说明:				SKU:			
1.所有产品边缘不能有毛刺, 覆膜面不能刮花;				名称:	建德C40+潜水俱乐部厨房		
2.公差要求标准: 符合GB/T G3280-2015不锈钢冷轧钢板和钢带标准中PT.A的公称宽度要求;				材料:			
3.所有标注尺寸为外尺寸;				编制:		日期:	
4.未注膜面方向朝外。				审核:		日期:	
A						视角:	☉
版本			批准	日期		版本:	A

STAINLESS STEEL SHOP DRAWING (CUSTOM)

不锈钢件生产要求图

Product Description (产品说明):	Work Table W/Under Shelf
	调料平台
Model Type (模具型号):	TBS1 BB16

No:	Parts(零部件):	Material Specification(用料标准):
✓ 01	COUNTER TOP 柜台面	16GA. THK. SUS 304 S/S
✓ 02	LEG 支腿	∅38mm 16 GA. THK. SUS 304 S/S TUBE
✓ 03	ADJUSTABLE FOOT INSERT 可调节嵌入式底脚	LUI CHUEN KEE (CHN)
✓ 04	REINFORCEMENT 加固件	16 GA. THK. SUS 304 S/S
05	SINK BOWL 洗碗槽	16 GA. THK. SUS 304 S/S
06	SINK WASTE 废料槽	
✓ 07	S.S. CROSS RAIL 横梁	∅32mm 16 GA. THK. SUS 304 S/S TUBE
08	WALL MOUNTED BRACKET 壁挂托架	16 GA. THK. SUS 304 S/S
09	UNDER SHELF 底架	18 GA. THK. SUS 304 S/S
10	MIXING FAUCET 混合龙头	
11	OVER SHELF 顶架	18 GA. THK. SUS 304 S/S
12	OUTER DOOR PANEL 外板	20 GA. THK. SUS 304 S/S
13	INNER DOOR PANEL 内板	22 GA. THK. SUS 304 S/S
14	CABINET BODY 柜身	20 GA. THK. SUS 304 S/S
15	CORNER BUMPER 拐角防护套	COLSON (CHN)
16	SWIVEL CASTOR 旋转角轮	GLOBE (CHN)
17	SOUND DEADEN MATERIAL 隔音材料	3mm THICKNESS
18	WALL FLASHING 防水面	20 GA. THK. SUS 304 S/S
19	CONDENSING UNIT 制冷机组	DANFOSS (CHN)
20	NOZZLE 排气口	∅25mm SUS 304 S/S TUBE

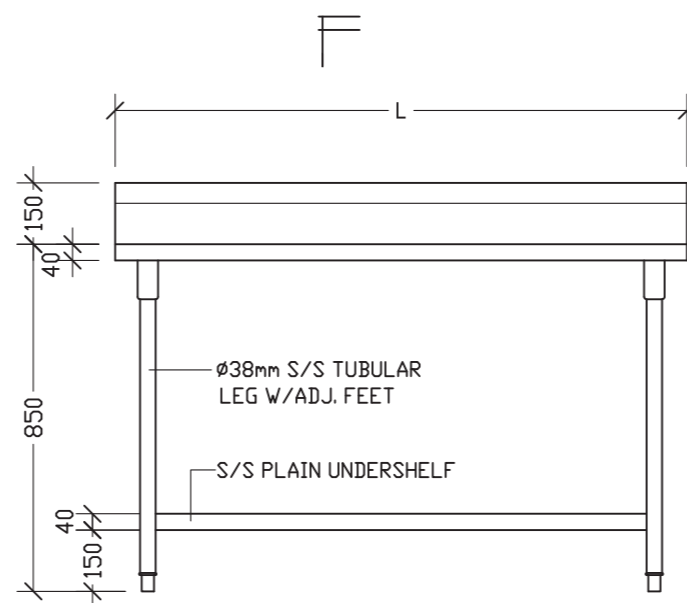

ELEVATION

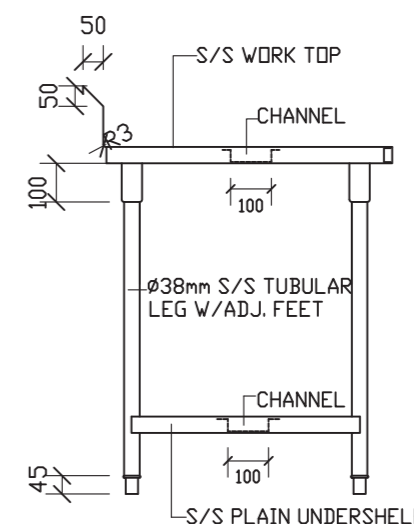

SECTION

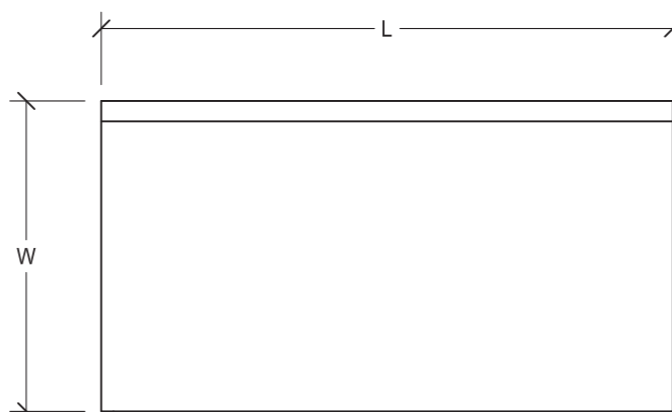

PLAN

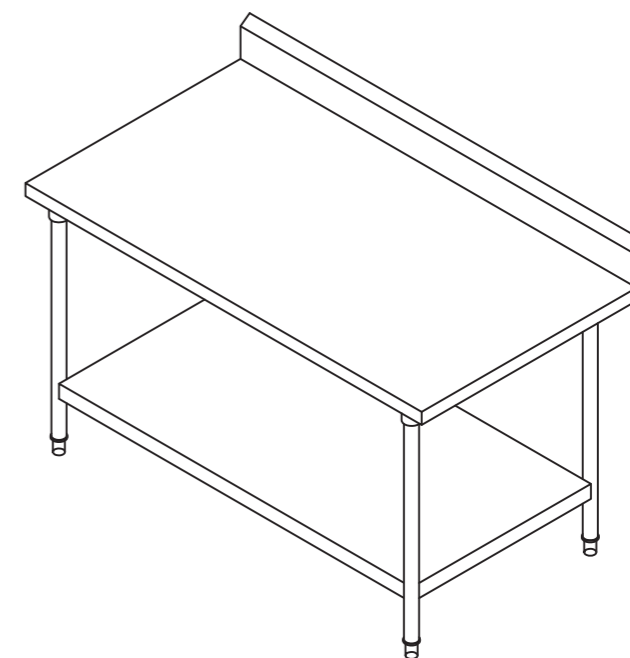

ISOMETRIC VIEW

No:	Item No(款号):	Qty(数量):	No:	Item No(款号):	Qty(数量):

Remark(备注):



SPOT WELDED A THREADED SHAFT TO THE UNDERSIDE OF WORK TOP / SHELF. THEN USE UNITS TO FIX WITH THE REINFORCEMENT / BRACKETS

技术说明:				SKU:			
1.所有产品边缘不能有毛刺, 覆膜面不能刮花;				名称:	建德C40+潜水俱乐部厨房		
2.公差要求标准: 符合GB/T G3280-2015不锈钢冷轧钢板和钢带标准中PT.A的公称宽度要求;				材料:			
3.所有标注尺寸为外尺寸;				编制:		日期:	
4.未注膜面方向朝外。				审核:		日期:	
A						视角:	☉
版本			批准	日期		版本:	A

STAINLESS STEEL SHOP DRAWING (CUSTOM)

不锈钢件生产要求图

Product Description (产品说明):	Work Cabinet
	工作掩门柜
Model Type (模具型号):	CBH CC05

No:	Parts(零部件):	Material Specification(用料标准):
✓ 01	COUNTER TOP 柜台面	16GA. THK. SUS 304 S/S
02	LEG 支腿	Ø38mm 16 GA. THK. SUS 304 S/S TUBE
✓ 03	ADJUSTABLE FOOT INSERT 可调节嵌入式底脚	LUI CHUEN KEE (CHN)
✓ 04	REINFORCEMENT 加固件	16 GA. THK. SUS 304 S/S
05	SINK BOWL 洗碗槽	16 GA. THK. SUS 304 S/S
06	SINK WASTE 废料槽	
07	S.S. CROSS RAIL 横梁	Ø32mm 16 GA. THK. SUS 304 S/S TUBE
08	WALL MOUNTED BRACKET 壁装托架	16 GA. THK. SUS 304 S/S
✓ 09	UNDER SHELF 底架	18 GA. THK. SUS 304 S/S
10	MIXING FAUCET 混合龙头	
11	OVER SHELF 顶架	18 GA. THK. SUS 304 S/S
✓ 12	OUTER DOOR PANEL 外板	20 GA. THK. SUS 304 S/S
✓ 13	INNER DOOR PANEL 内板	22 GA. THK. SUS 304 S/S
✓ 14	CABINET BODY 柜身	20 GA. THK. SUS 304 S/S
15	CORNER BUMPER 拐角防护套	COLSON (CHN)
16	SWIVEL CASTOR 旋转角轮	GLOBE (CHN)
17	SOUND DEADEN MATERIAL 隔音材料	3mm THICKNESS
18	WALL FLASHING 防水面	20 GA. THK. SUS 304 S/S
19	CONDENSING UNIT 制冷机组	DANFOSS (CHN)
20	NOZZLE 排气口	Ø25mm SUS 304 S/S TUBE

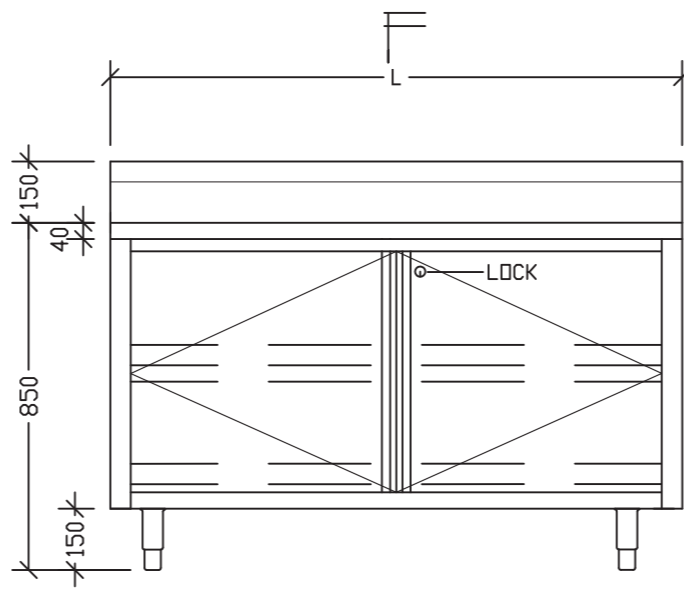

ELEVATION

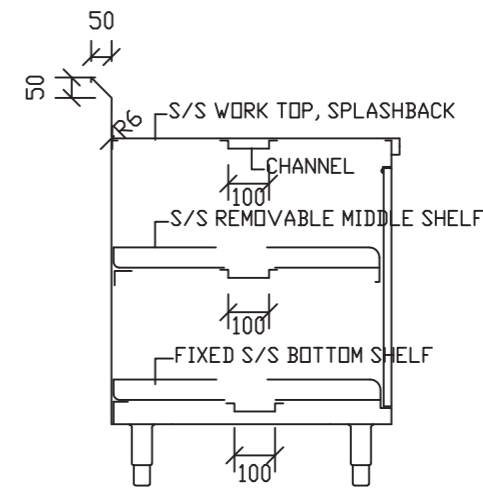

SECTION

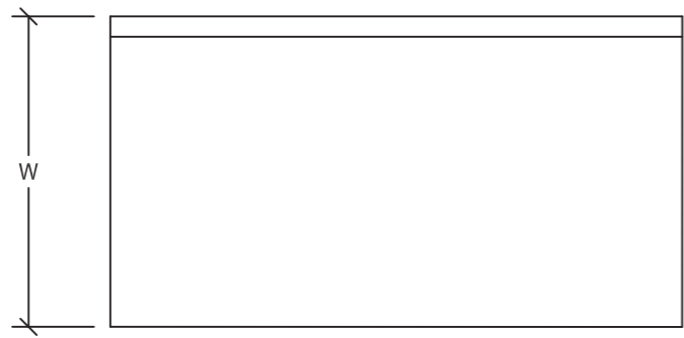

PLAN

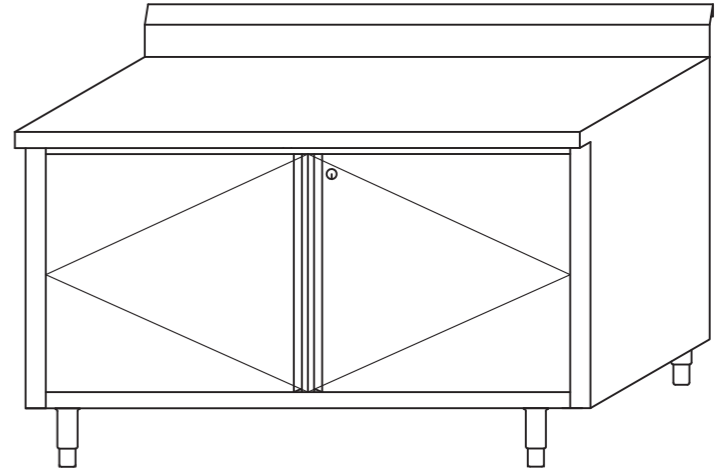

ISOMETRIC VIEW

No:	Item No(款号):	Qty(数量):	No:	Item No(款号):	Qty(数量):

Remark(备注):



SPOT WELDED A THREADED SHAFT TO THE UNDERSIDE OF WORK TOP / SHELF. THEN USE UNITS TO FIX WITH THE REINFORCEMENT / BRACKETS

技术说明:				SKU:			
1.所有产品边缘不能有毛刺, 覆膜面不能刮花;				名称:	建德C40+潜水俱乐部厨房		
2.公差要求标准: 符合GB/T G3280-2015不锈钢冷轧钢板和钢带标准中PT.A的公称宽度要求;				材料:			
3.所有标注尺寸为外尺寸;				编制:		日期:	
4.未注膜面方向朝外。				审核:		日期:	
A						视角:	☉
版本			批准	日期		版本:	A

STAINLESS STEEL SHOP DRAWING (CUSTOM)

不锈钢件生产要求图

Product Description (产品说明):	Work Cabinet
	工作掩门柜
Model Type (模具型号):	CBH DD02

No:	Parts(零部件):	Material Specification(用料标准):
✓ 01	COUNTER TOP 柜台面	16GA. THK. SUS 304 S/S
02	LEG 支腿	Ø38mm 16 GA. THK. SUS 304 S/S TUBE
✓ 03	ADJUSTABLE FOOT INSERT 可调节嵌入式底脚	LUI CHUEN KEE (CHN)
✓ 04	REINFORCEMENT 加固件	16 GA. THK. SUS 304 S/S
05	SINK BOWL 洗碗槽	16 GA. THK. SUS 304 S/S
06	SINK WASTE 废料槽	
07	S.S. CROSS RAIL 横梁	Ø32mm 16 GA. THK. SUS 304 S/S TUBE
08	WALL MOUNTED BRACKET 壁挂托架	16 GA. THK. SUS 304 S/S
✓ 09	UNDER SHELF 底架	18 GA. THK. SUS 304 S/S
10	MIXING FAUCET 混合龙头	
11	OVER SHELF 顶架	18 GA. THK. SUS 304 S/S
✓ 12	OUTER DOOR PANEL 外板	20 GA. THK. SUS 304 S/S
✓ 13	INNER DOOR PANEL 内板	22 GA. THK. SUS 304 S/S
✓ 14	CABINET BODY 柜身	20 GA. THK. SUS 304 S/S
15	CORNER BUMPER 拐角防护套	COLSON (CHN)
16	SWIVEL CASTOR 旋转角轮	GLOBE (CHN)
17	SOUND DEADEN MATERIAL 隔音材料	3mm THICKNESS
18	WALL FLASHING 防水面	20 GA. THK. SUS 304 S/S
19	CONDENSING UNIT 制冷机组	DANFOSS (CHN)
20	NOZZLE 排气口	Ø25mm SUS 304 S/S TUBE

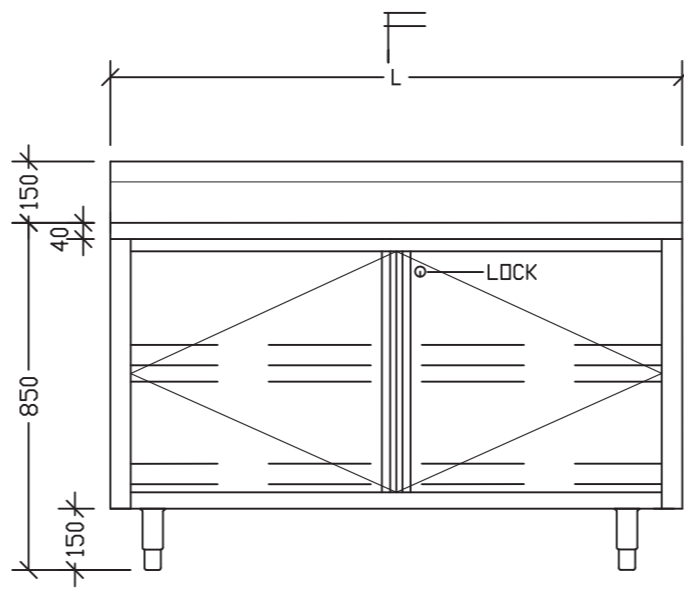

ELEVATION

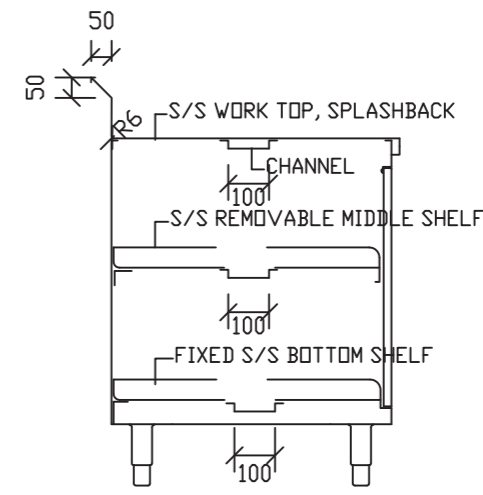

SECTION

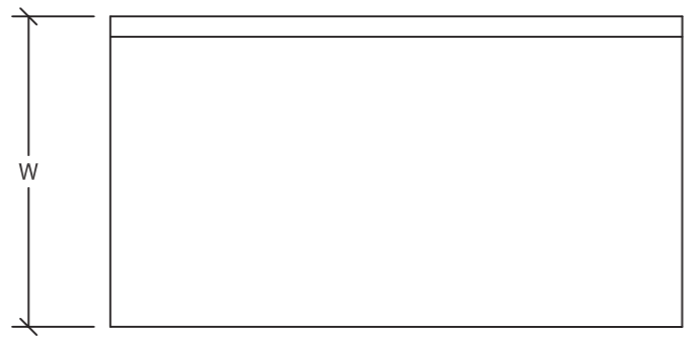

PLAN

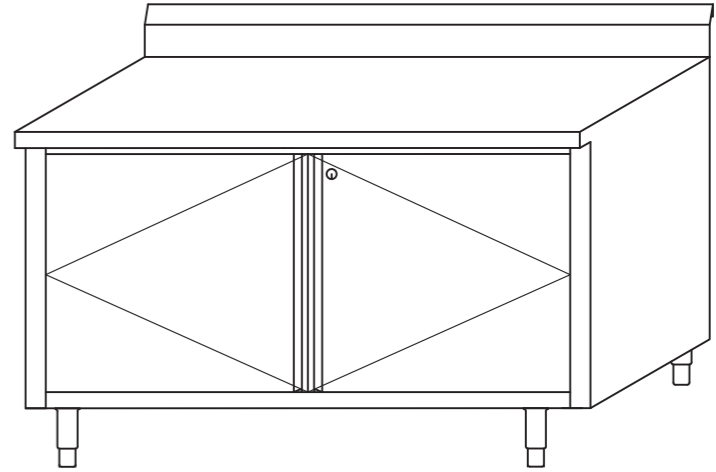

ISOMETRIC VIEW

No:	Item No(款号):	Qty(数量):	No:	Item No(款号):	Qty(数量):

Remark(备注):



SPOT WELDED A THREADED SHAFT TO THE UNDERSIDE OF WORK TOP / SHELF. THEN USE UNITS TO FIX WITH THE REINFORCEMENT / BRACKETS

技术说明:				SKU:			
1.所有产品边缘不能有毛刺, 覆膜面不能刮花;				名称:	建德C40+潜水俱乐部厨房		
2.公差要求标准: 符合GB/T G3280-2015不锈钢冷轧钢板和钢带标准中PT.A的公称宽度要求;				材料:			
3.所有标注尺寸为外尺寸;				编制:		日期:	
4.未注膜面方向朝外。				审核:		日期:	
A						视角:	☉
版本			批准	日期		版本:	A

STAINLESS STEEL SHOP DRAWING (CUSTOM)

不锈钢件生产要求图

Product Description (产品说明):	Work Cabinet
	工作掩门柜
Model Type (模具型号):	CBH DD03

No:	Parts(零部件):	Material Specification(用料标准):
✓ 01	COUNTER TOP 柜台面	16GA. THK. SUS 304 S/S
02	LEG 支腿	Ø38mm 16 GA. THK. SUS 304 S/S TUBE
✓ 03	ADJUSTABLE FOOT INSERT 可调节嵌入式底脚	LUI CHUEN KEE (CHN)
✓ 04	REINFORCEMENT 加固件	16 GA. THK. SUS 304 S/S
05	SINK BOWL 洗碗槽	16 GA. THK. SUS 304 S/S
06	SINK WASTE 废料槽	
07	S.S. CROSS RAIL 横梁	Ø32mm 16 GA. THK. SUS 304 S/S TUBE
08	WALL MOUNTED BRACKET 壁装托架	16 GA. THK. SUS 304 S/S
✓ 09	UNDER SHELF 底架	18 GA. THK. SUS 304 S/S
10	MIXING FAUCET 混合龙头	
11	OVER SHELF 顶架	18 GA. THK. SUS 304 S/S
✓ 12	OUTER DOOR PANEL 外板	20 GA. THK. SUS 304 S/S
✓ 13	INNER DOOR PANEL 内板	22 GA. THK. SUS 304 S/S
✓ 14	CABINET BODY 柜身	20 GA. THK. SUS 304 S/S
15	CORNER BUMPER 拐角防护套	COLSON (CHN)
16	SWIVEL CASTOR 旋转角轮	GLOBE (CHN)
17	SOUND DEADEN MATERIAL 隔音材料	3mm THICKNESS
18	WALL FLASHING 防水面	20 GA. THK. SUS 304 S/S
19	CONDENSING UNIT 制冷机组	DANFOSS (CHN)
20	NOZZLE 排气口	Ø25mm SUS 304 S/S TUBE

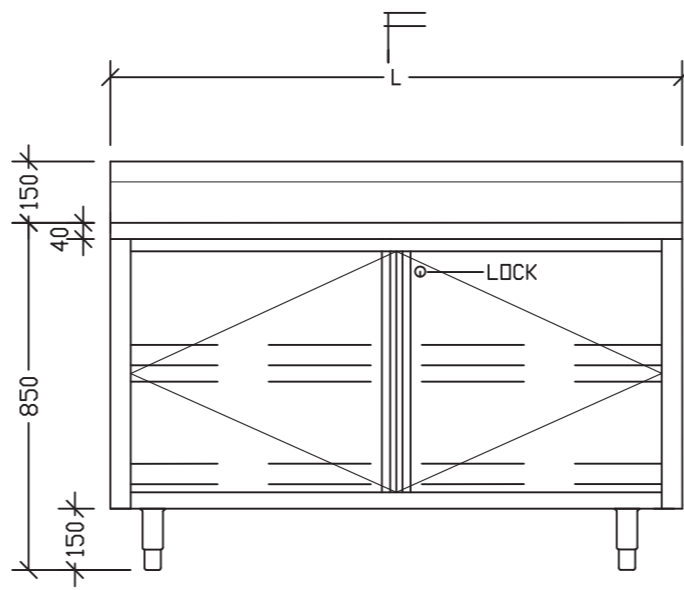

ELEVATION

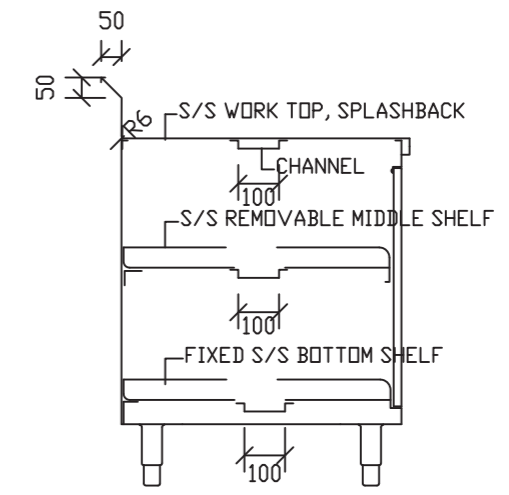

SECTION

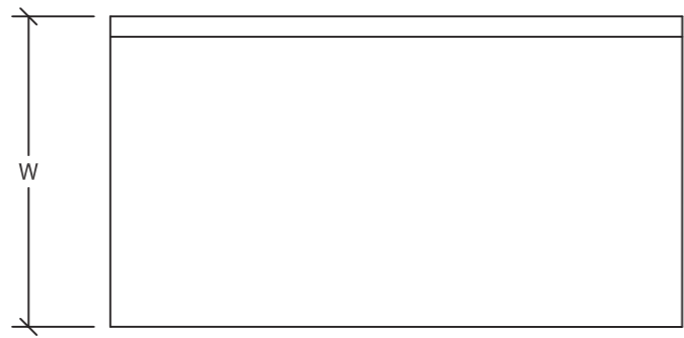

PLAN

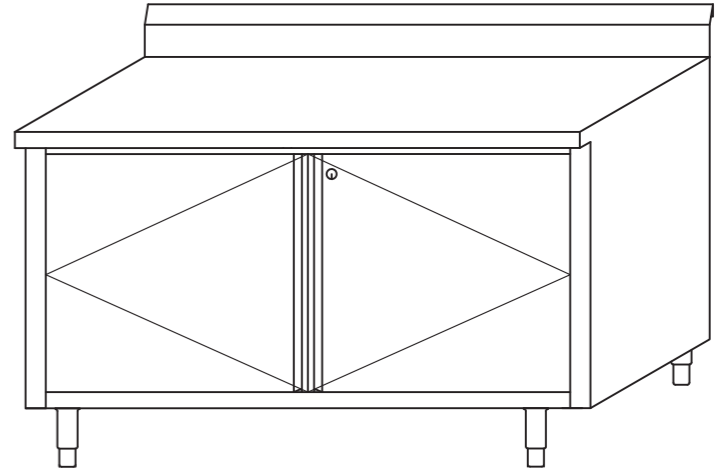

ISOMETRIC VIEW

No:	Item No(款号):	Qty(数量):	No:	Item No(款号):	Qty(数量):

Remark(备注):



SPOT WELDED A THREADED SHAFT TO THE UNDERSIDE OF WORK TOP / SHELF. THEN USE UNITS TO FIX WITH THE REINFORCEMENT / BRACKETS

技术说明:				SKU:			
1.所有产品边缘不能有毛刺, 覆膜面不能刮花;				名称:	建德C40+潜水俱乐部厨房		
2.公差要求标准: 符合GB/T G3280-2015不锈钢冷轧钢板和钢带标准中PT.A的公称宽度要求;				材料:			
3.所有标注尺寸为外尺寸;				编制:		日期:	
4.未注膜面方向朝外。				审核:		日期:	
A						视角:	☉
版本			批准	日期		版本:	A

STAINLESS STEEL SHOP DRAWING (CUSTOM)

不锈钢件生产要求图

Product Description (产品说明):	Work Table W/Twin Sinks
	工作台连双星盆 (中间去水)
Model Type (模具型号):	STSH2 DD04

No:	Parts(零部件):	Material Specification(用料标准):
✓ 01	COUNTER TOP 柜台面	16GA. THK. SUS 304 S/S
✓ 02	LEG 支腿	∅38mm 16 GA. THK. SUS 304 S/S TUBE
✓ 03	ADJUSTABLE FOOT INSERT 可调节嵌入式底脚	LUI CHUEN KEE (CHN)
✓ 04	REINFORCEMENT 加固件	16 GA. THK. SUS 304 S/S
✓ 05	SINK BOWL 洗碗槽	16 GA. THK. SUS 304 S/S
06	SINK WASTE 废料槽	
✓ 07	S.S. CROSS RAIL 横梁	∅32mm 16 GA. THK. SUS 304 S/S TUBE
08	WALL MOUNTED BRACKET 壁装托架	16 GA. THK. SUS 304 S/S
09	UNDER SHELF 底架	18 GA. THK. SUS 304 S/S
✓ 10	MIXING FAUCET 混合龙头	
11	OVER SHELF 顶架	18 GA. THK. SUS 304 S/S
12	OUTER DOOR PANEL 外板	20 GA. THK. SUS 304 S/S
13	INNER DOOR PANEL 内板	22 GA. THK. SUS 304 S/S
14	CABINET BODY 柜身	20 GA. THK. SUS 304 S/S
15	CORNER BUMPER 拐角防护套	COLSON (CHN)
16	SWIVEL CASTOR 旋转角轮	GLOBE (CHN)
17	SOUND DEADEN MATERIAL 隔音材料	3mm THICKNESS
18	WALL FLASHING 防水面	20 GA. THK. SUS 304 S/S
19	CONDENSING UNIT 制冷机组	DANFOSS (CHN)
20	NOZZLE 排气口	∅25mm SUS 304 S/S TUBE

No:	Item No(款号):	Qty(数量):	No:	Item No(款号):	Qty(数量):

Remark(备注):

 M5

SPOT WELDED A THREADED SHAFT TO THE UNDERSIDE OF WORK TOP / SHELF. THEN USE UNITS TO FIX WITH THE REINFORCEMENT / BRACKETS

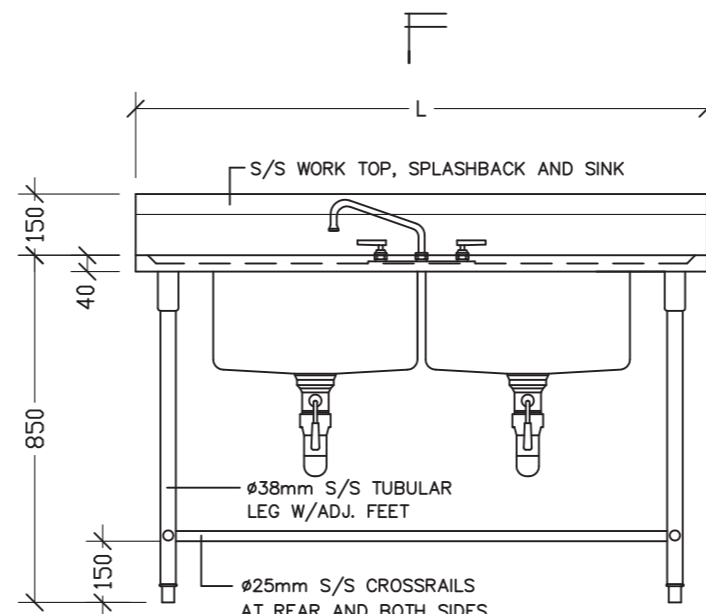

ELEVATION

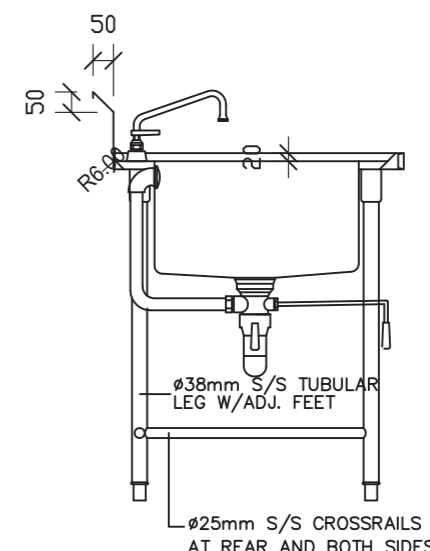

SECTION

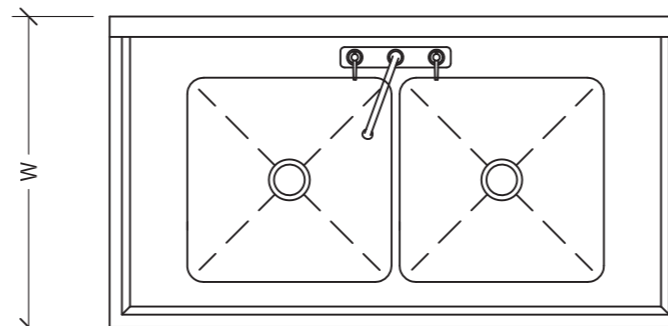

PLAN

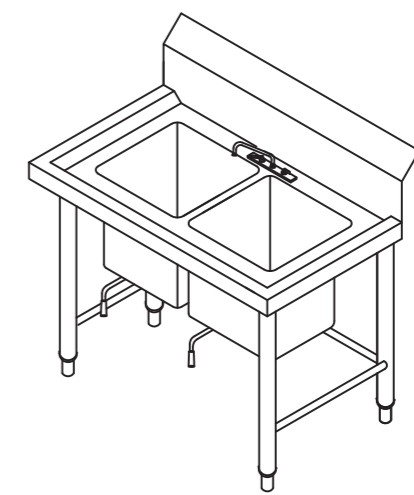

ISOMETRIC VIEW

技术说明:				SKU:			
1.所有产品边缘不能有毛刺, 覆膜面不能刮花;				名称:	建德C40+潜水俱乐部厨房		
2.公差要求标准: 符合GB/T G3280-2015不锈钢冷轧钢板和钢带标准中PT.A的公称宽度要求;				材料:			
3.所有标注尺寸为外尺寸;				编制:		日期:	
4.未注膜面方向朝外。				审核:		日期:	
A						视角:	
版本		批准	日期			版本:	A

STAINLESS STEEL SHOP DRAWING (CUSTOM)

不锈钢件生产要求图

Product Description (产品说明):	Work Table W/Under Shelf
	双层工作台
Model Type (模具型号):	TBS1 EE02

No:	Parts(零部件):	Material Specification(用料标准):
✓ 01	COUNTER TOP 柜台面	16GA. THK. SUS 304 S/S
✓ 02	LEG 支腿	Ø38mm 16 GA. THK. SUS 304 S/S TUBE
✓ 03	ADJUSTABLE FOOT INSERT 可调节嵌入式底脚	LUI CHUEN KEE (CHN)
✓ 04	REINFORCEMENT 加固件	16 GA. THK. SUS 304 S/S
05	SINK BOWL 洗碗槽	16 GA. THK. SUS 304 S/S
06	SINK WASTE 废料槽	
✓ 07	S.S. CROSS RAIL 横梁	Ø32mm 16 GA. THK. SUS 304 S/S TUBE
08	WALL MOUNTED BRACKET 壁挂托架	16 GA. THK. SUS 304 S/S
09	UNDER SHELF 底架	18 GA. THK. SUS 304 S/S
10	MIXING FAUCET 混合龙头	
11	OVER SHELF 顶架	18 GA. THK. SUS 304 S/S
12	OUTER DOOR PANEL 外板	20 GA. THK. SUS 304 S/S
13	INNER DOOR PANEL 内板	22 GA. THK. SUS 304 S/S
14	CABINET BODY 柜身	20 GA. THK. SUS 304 S/S
15	CORNER BUMPER 拐角防护套	COLSON (CHN)
16	SWIVEL CASTOR 旋转角轮	GLOBE (CHN)
17	SOUND DEADEN MATERIAL 隔音材料	3mm THICKNESS
18	WALL FLASHING 防水面	20 GA. THK. SUS 304 S/S
19	CONDENSING UNIT 制冷机组	DANFOSS (CHN)
20	NOZZLE 排气口	Ø25mm SUS 304 S/S TUBE

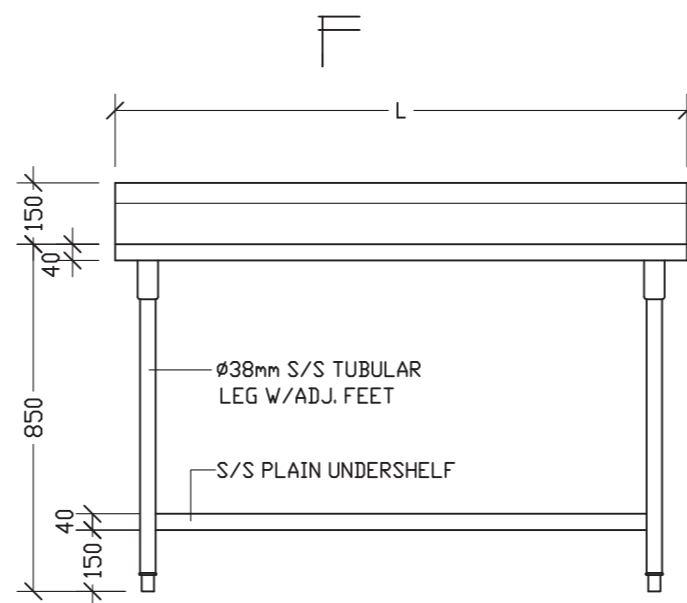

ELEVATION

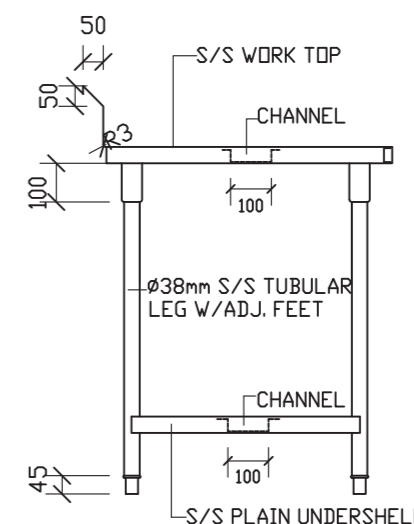

SECTION

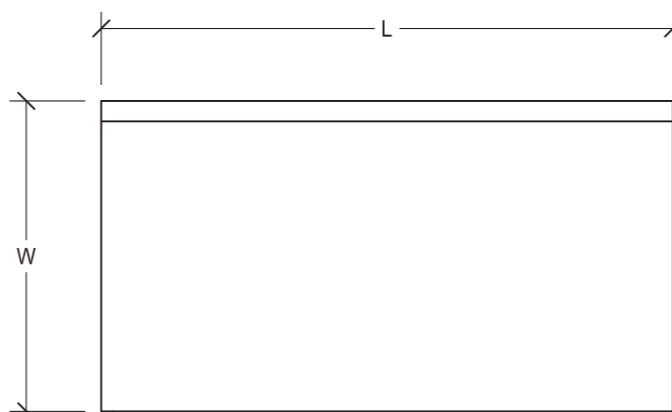

PLAN

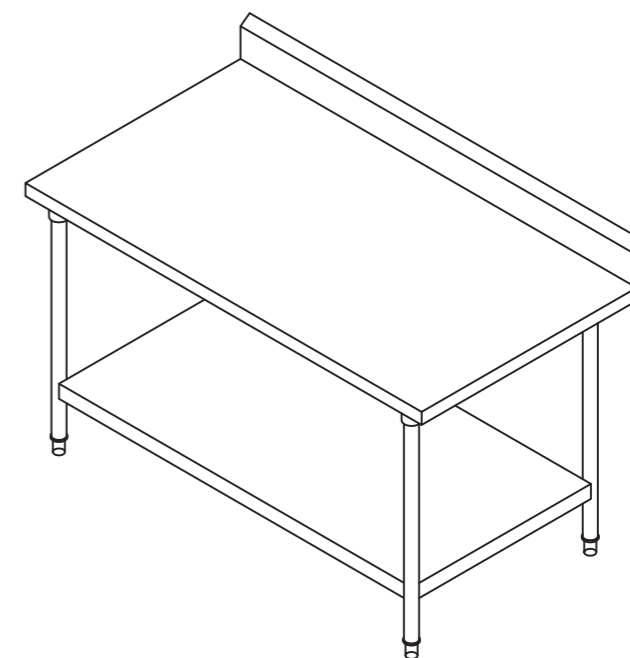

ISOMETRIC VIEW

No:	Item No(款号):	Qty(数量):	No:	Item No(款号):	Qty(数量):

Remark(备注):



SPOT WELDED A THREADED SHAFT TO THE UNDERSIDE OF WORK TOP / SHELF. THEN USE UNITS TO FIX WITH THE REINFORCEMENT / BRACKETS

技术说明:				SKU:			
1.所有产品边缘不能有毛刺, 覆膜面不能刮花;				名称:	建德C40+潜水俱乐部厨房		
2.公差要求标准: 符合GB/T G3280-2015不锈钢冷轧钢板和钢带标准中PT.A的公称宽度要求;				材料:			
3.所有标注尺寸为外尺寸;				编制:		日期:	
4.未注膜面方向朝外。				审核:		日期:	
A						视角:	☉ ☒
版本			批准	日期		版本:	A

STAINLESS STEEL SHOP DRAWING (CUSTOM)

不锈钢件生产要求图

Product Description (产品说明):	Work Cabinet W/Waste Bin & Double Sinks
	双星盆柜连垃圾桶柜
Model Type (模具型号):	CBGB-HS2 EE09

No:	Parts(零部件):	Material Specification(用料标准):
✓ 01	COUNTER TOP 柜台面	16GA. THK. SUS 304 S/S
02	LEG 支腿	∅38mm 16 GA. THK. SUS 304 S/S TUBE
✓ 03	ADJUSTABLE FOOT INSERT 可调节嵌入式底脚	LUI CHUEN KEE (CHN)
✓ 04	REINFORCEMENT 加固件	16 GA. THK. SUS 304 S/S
✓ 05	SINK BOWL 洗碗槽	16 GA. THK. SUS 304 S/S
✓ 06	SINK WASTE 废料槽	
07	S.S. CROSS RAIL 横梁	∅32mm 16 GA. THK. SUS 304 S/S TUBE
08	WALL MOUNTED BRACKET 壁装托架	16 GA. THK. SUS 304 S/S
✓ 09	UNDER SHELF 底架	18 GA. THK. SUS 304 S/S
✓ 10	MIXING FAUCET 混合龙头	
11	OVER SHELF 顶架	18 GA. THK. SUS 304 S/S
✓ 12	OUTER DOOR PANEL 外板	20 GA. THK. SUS 304 S/S
✓ 13	INNER DOOR PANEL 内板	22 GA. THK. SUS 304 S/S
✓ 14	CABINET BODY 柜身	20 GA. THK. SUS 304 S/S
15	CORNER BUMPER 拐角防护套	COLSON (CHN)
16	SWIVEL CASTOR 旋转角轮	GLOBE (CHN)
17	SOUND DEADEN MATERIAL 隔音材料	3mm THICKNESS
18	WALL FLASHING 防水面	20 GA. THK. SUS 304 S/S
19	CONDENSING UNIT 制冷机组	DANFOSS (CHN)
20	NOZZLE 排气口	∅25mm SUS 304 S/S TUBE

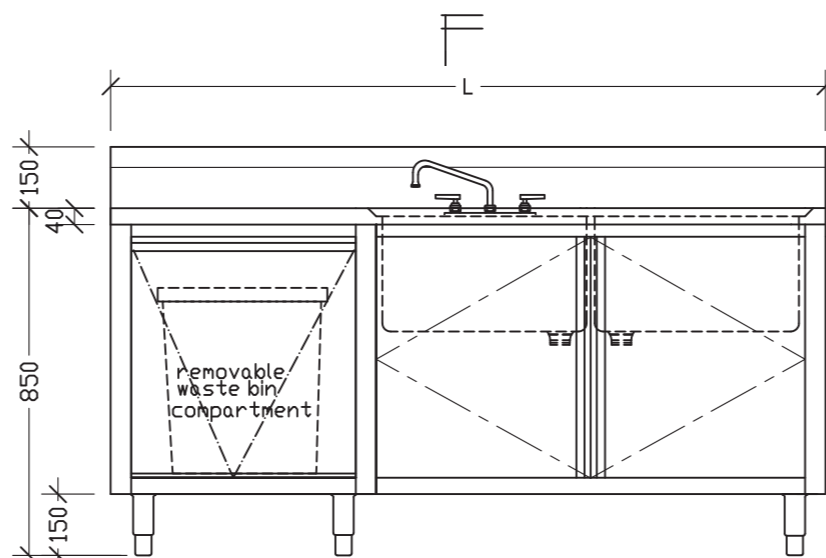

ELEVATION

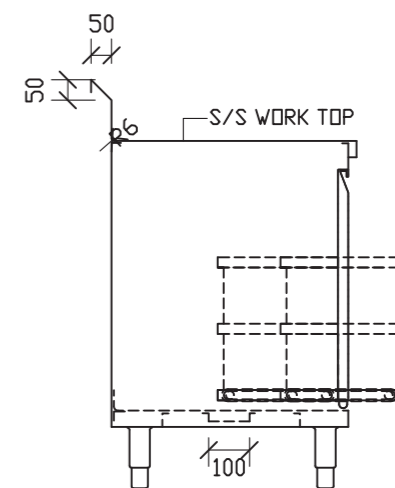

SECTION

No:	Item No(款号):	Qty(数量):	No:	Item No(款号):	Qty(数量):

Remark(备注):



SPOT WELDED A THREADED SHAFT TO THE UNDERSIDE OF WORK TOP / SHELF. THEN USE UNITS TO FIX WITH THE REINFORCEMENT / BRACKETS

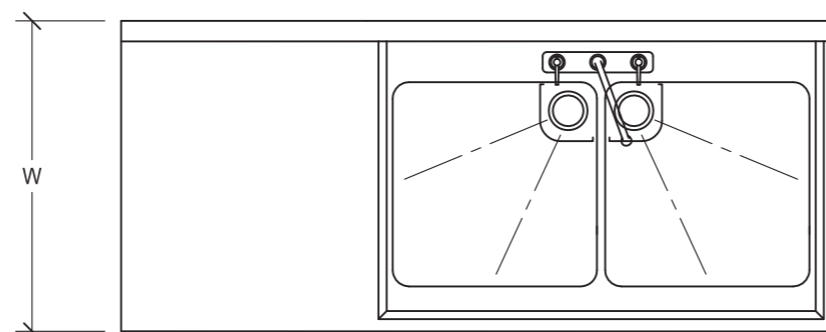

PLAN

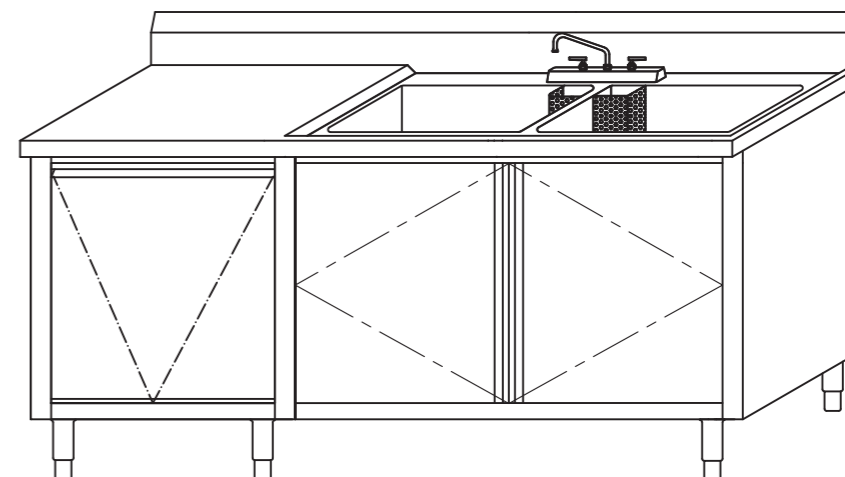

ISOMETRIC VIEW

技术说明:				SKU:			
1.所有产品边缘不能有毛刺, 覆膜面不能刮花;				名称:	建德C40+潜水俱乐部厨房		
2.公差要求标准: 符合GB/T G3280-2015不锈钢冷轧钢板和钢带标准中PT.A的公称宽度要求;				材料:			
3.所有标注尺寸为外尺寸;				编制:		日期:	
4.未注膜面方向朝外。				审核:		日期:	
A						视角:	☉
版本		批准	日期			版本:	A

STAINLESS STEEL SHOP DRAWING (CUSTOM)

不锈钢件生产要求图

Product Description (产品说明):

Fish Tank

鱼缸

Model Type (模具型号):

FIST

No:	Parts(零部件):	Material Specfication(用料标准):
01	COUNTER TOP 柜台面	16GA. THK. SUS 304 S/S
02	LEG 支腿	Ø38mm 16 GA. THK. SUS 304 S/S TUBE
03	ADJUSTABLE FOOT INSERT 可调节嵌入式底脚	LUI CHUEN KEE (CHN)
04	REINFORCEMENT 加固件	16 GA. THK. SUS 304 S/S
05	SINK BOWL 洗碗槽	16 GA. THK. SUS 304 S/S
06	SINK WASTE 废料槽	
07	S.S. CROSS RAIL 横梁	Ø32mm 16 GA. THK. SUS 304 S/S TUBE
08	WALL MOUNTED BRACKET 壁装托架	16 GA. THK. SUS 304 S/S
09	UNDER SHELF 底架	18 GA. THK. SUS 304 S/S
10	MIXING FAUCET 混合龙头	
11	OVER SHELF 顶架	18 GA. THK. SUS 304 S/S
12	OUTER DOOR PANEL 外板	20 GA. THK. SUS 304 S/S
13	INNER DOOR PANEL 内板	22 GA. THK. SUS 304 S/S
14	CABINET BODY 柜身	20 GA. THK. SUS 304 S/S
15	CORNER BUMPER 拐角防护套	COLSON (CHN)
16	SWIVEL CASTOR 旋转角轮	GLOBE (CHN)
17	SOUND DEADEN MATERIAL 隔音材料	3mm THICKNESS
18	WALL FLASHING 防水面	20 GA. THK. SUS 304 S/S
19	CONDENSING UNIT 制冷机组	DANFOSS (CHN)
20	NOZZLE 排气口	Ø25mm SUS 304 S/S TUBE

No:	Item No(款号):	Qty(数量):	No:	Item No(款号):	Qty(数量):

Remark(备注):



SPOT WELDED A THREADED SHAFT TO THE UNDERSIDE OF WORK TOP / SHELF. THEN USE UNITS TO FIX WITH THE REINFORCEMENT / BRACKETS
在工作台面或层板的底部焊接一个螺栓用来固定加强筋或支架

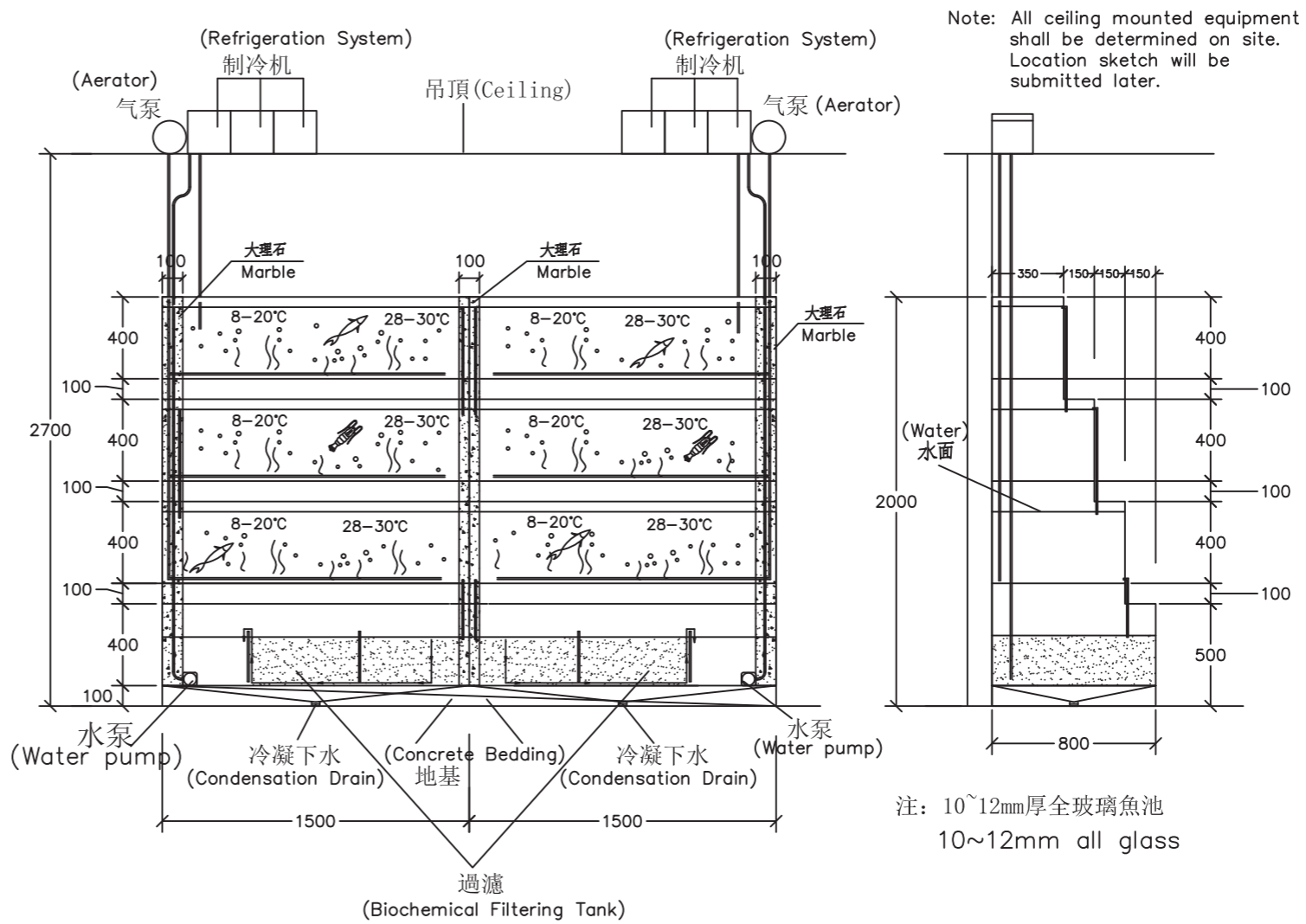

ELEVATION

(主视图)

SECTION

(侧视图)

技术说明:
1.所有产品边缘不能有毛刺, 覆膜面不能刮花;
2.公差要求标准: 符合GB/T G3280-2015不锈钢冷轧钢板和钢带标准中PT.A的公称宽度要求;
3.所有标注尺寸为外尺寸;
4.未注膜面方向朝外。

SKU:
名称: 建德C40+潜水俱乐部厨房
材料:
编制:
审核:

日期:
日期:
视角:
版本: A

批准 日期

STAINLESS STEEL SHOP DRAWING (CUSTOM)

不锈钢件生产要求图

Product Description (产品说明):	S/S Wall Flashing
	不锈钢护墙板
Model Type (模具型号):	ZSWF

No:	Parts(零部件):	Material Specfication(用料标准):
01	COUNTER TOP 柜台面	16GA. THK. SUS 304 S/S
02	LEG 支腿	Ø38mm 16 GA. THK. SUS 304 S/S TUBE
03	ADJUSTABLE FOOT INSERT 可调节嵌入式底脚	LUI CHUEN KEE (CHN)
04	REINFORCEMENT 加固件	16 GA. THK. SUS 304 S/S
05	SINK BOWL 洗碗槽	16 GA. THK. SUS 304 S/S
06	SINK WASTE 废料槽	
07	S.S. CROSS RAIL 横梁	Ø32mm 16 GA. THK. SUS 304 S/S TUBE
08	WALL MOUNTED BRACKET 壁装托架	16 GA. THK. SUS 304 S/S
09	UNDER SHELF 底架	18 GA. THK. SUS 304 S/S
10	MIXING FAUCET 混合龙头	
11	OVER SHELF 顶架	18 GA. THK. SUS 304 S/S
12	OUTER DOOR PANEL 外板	20 GA. THK. SUS 304 S/S
13	INNER DOOR PANEL 内板	22 GA. THK. SUS 304 S/S
14	CABINET BODY 柜身	20 GA. THK. SUS 304 S/S
15	CORNER BUMPER 拐角防护套	COLSON (CHN)
16	SWIVEL CASTOR 旋转角轮	GLOBE (CHN)
17	SOUND DEADEN MATERIAL 隔音材料	3mm THICKNESS
✓ 18	WALL FLASHING 防水面	20 GA. THK. SUS 304 S/S
19	CONDENSING UNIT 制冷机组	DANFOSS (CHN)
20	NOZZLE 排气口	Ø25mm SUS 304 S/S TUBE

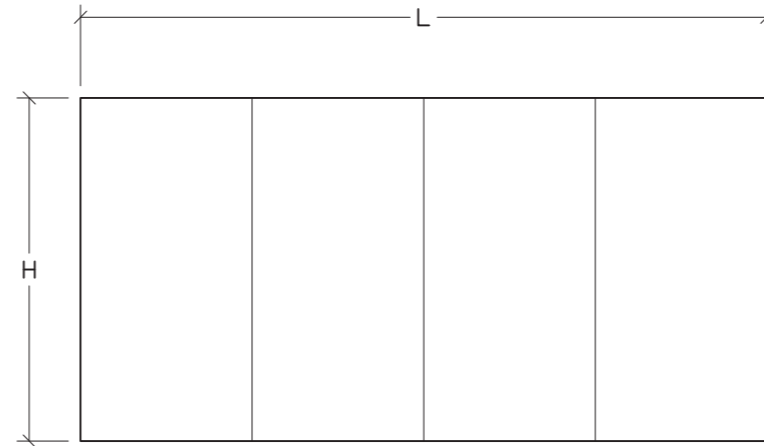

ELEVATION

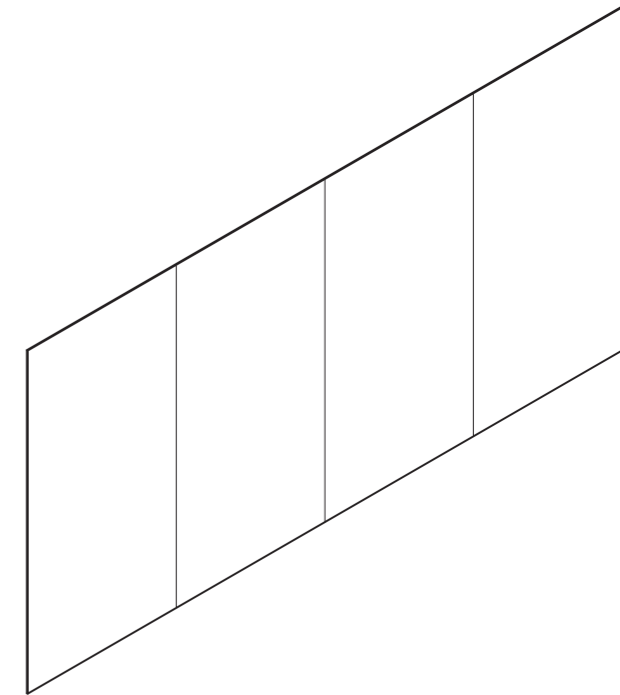

ISOMETRIC VIEW

No:	Item No(款号):	Qty(数量):	No:	Item No(款号):	Qty(数量):

Remark(备注):



SPOT WELDED A THREADED SHAFT TO THE UNDERSIDE OF WORK TOP / SHELF. THEN USE UNITS TO FIX WITH THE REINFORCEMENT / BRACKETS

				技术说明:	SKU:					
				1.所有产品边缘不能有毛刺, 覆膜面不能刮花;	名称:	建德C40+潜水俱乐部厨房				
				2.公差要求标准: 符合GB/T G3280-2015不锈钢冷轧钢板和钢带标准中PT.A的公称宽度要求;	材料:					
				3.所有标注尺寸为外尺寸;	编制:			日期:		
				4.未注膜面方向朝外。	审核:			日期:		
A				批准	日期			视角:	☉ ☒	
版本								版本:	A	